

TFT LCD Approval Specification

MODEL NO.: N154C6 - L02

Customer : _____

Approved by : _____

Note :

Liquid Crystal Display Division	
QRA Division.	OA Head Division.
Approval	Approval

- CONTENTS -

REVISION HISTORY	-----	3
1. GENERAL DESCRIPTION	-----	4
1.1 OVERVIEW		
1.2 FEATURES		
1.3 APPLICATION		
1.4 GENERAL SPECIFICATIONS		
1.5 MECHANICAL SPECIFICATIONS		
2. ABSOLUTE MAXIMUM RATINGS	-----	5
2.1 ABSOLUTE RATINGS OF ENVIRONMENT		
2.2 ELECTRICAL ABSOLUTE RATINGS		
2.2.1 TFT LCD MODULE		
2.2.2 BACKLIGHT UNIT		
3. ELECTRICAL CHARACTERISTICS	-----	7
3.1 TFT LCD MODULE		
3.2 BACKLIGHT UNIT		
4. BLOCK DIAGRAM	-----	10
4.1 TFT LCD MODULE		
5. INPUT TERMINAL PIN ASSIGNMENT	-----	11
5.1 TFT LCD MODULE		
5.2 TIMING DIAGRAM OF LVDS INPUT SIGNAL		
5.3 COLOR DATA INPUT ASSIGNMENT		
5.4 EDID CODE DATA STRUCTURE		
6. INTERFACE TIMING	-----	17
6.1 INPUT SIGNAL TIMING SPECIFICATIONS		
6.2 POWER ON/OFF SEQUENCE		
7. OPTICAL CHARACTERISTICS	-----	19
7.1 TEST CONDITIONS		
7.2 OPTICAL SPECIFICATIONS		
8. PRECAUTIONS	-----	23
8.1 HANDLING PRECAUTIONS		
8.2 STORAGE PRECAUTIONS		
8.3 OPERATION PRECAUTIONS		
9. PACKING	-----	24
9.1 CARTON		
9.2 PALLET FOR SEA FREIGHT		
9.3 PALLET FOR AIR FREIGHT		
10. DEFINITION OF LABELS	-----	26
10.1 CMO MODULE LABEL		
10.2 CMO CARTON LABEL		

REVISION HISTORY

Version	Date	Page (New)	Section	Description
Ver. 2.0	Oct. 19, '07			Approval Specification was first issued

1. GENERAL DESCRIPTION

1.1 OVERVIEW

N154C6 - L01 is a 15.4" TFT Liquid Crystal Display module with LED Backlight unit and 40 pins LVDS interface. This module supports 1440 x 900 Wide-XGA+ mode and can display 262,144 colors. The optimum viewing angle is at 6 o'clock direction. The converter module for Backlight is not built in.

1.2 FEATURES

- Thin and High Brightness
- WXGA + (1440 x 900 pixels) resolution
- 3.3V LVDS (Low Voltage Differential Signaling) interface with 2 pixel/clock
- RoHS compliance

1.3 APPLICATION

- TFT LCD Notebook

1.4 GENERAL SPECIFICATIONS

Item	Specification	Unit	Note
Active Area	331.560(H) x 207.225(V) (15.4" diagonal)	mm	(1)
Bezel Opening Area	334.6 (H) x 211.1 (V)	mm	
Driver Element	a-si TFT active matrix	-	-
Pixel Number	1440 (H) x 3 (R.G.B.) x 900 (V)	pixel	-
Pixel Pitch	0.23025 (H) x 0.23025 (V)	mm	-
Pixel Arrangement	RGB vertical stripe	-	-
Display Colors	262,144	color	-
Transmissive Mode	Normally white	-	-
Surface Treatment	3H, Glare Type	-	-

1.5 MECHANICAL SPECIFICATIONS

Item	Min.	Typ.	Max.	Unit	Note	
Module Size	Horizontal (H)	343.7	344.0	344.3	mm	(1)
	Vertical (V)	221.7	222.0	222.3	mm	
	Depth (D)	5.5	5.8	6.1	mm	
Weight	---	430	450	g	-	

Note (1) Please refer to the attached drawings for more information of front and back outline dimensions.

2. ABSOLUTE MAXIMUM RATINGS

2.1 ABSOLUTE RATINGS OF ENVIRONMENT

Item	Symbol	Value		Unit	Note
		Min.	Max.		
Storage Temperature	T _{ST}	-20	+60	°C	(1)
Operating Ambient Temperature	T _{OP}	0	+50	°C	(1), (2)
Shock (Non-Operating)	S _{NOP}	-	200/2	G/ms	(3), (5)
Vibration (Non-Operating)	V _{NOP}	-	1.5	G	(4), (5)

Note (1) (a) 90 %RH Max. (Ta ≤ 40 °C).

(b) Wet-bulb temperature should be 39 °C Max. (Ta > 40 °C).

(c) No condensation.

Note (2) The temperature of panel display surface area should be 0 °C Min. and 50 °C Max.

Relative Humidity (%RH)

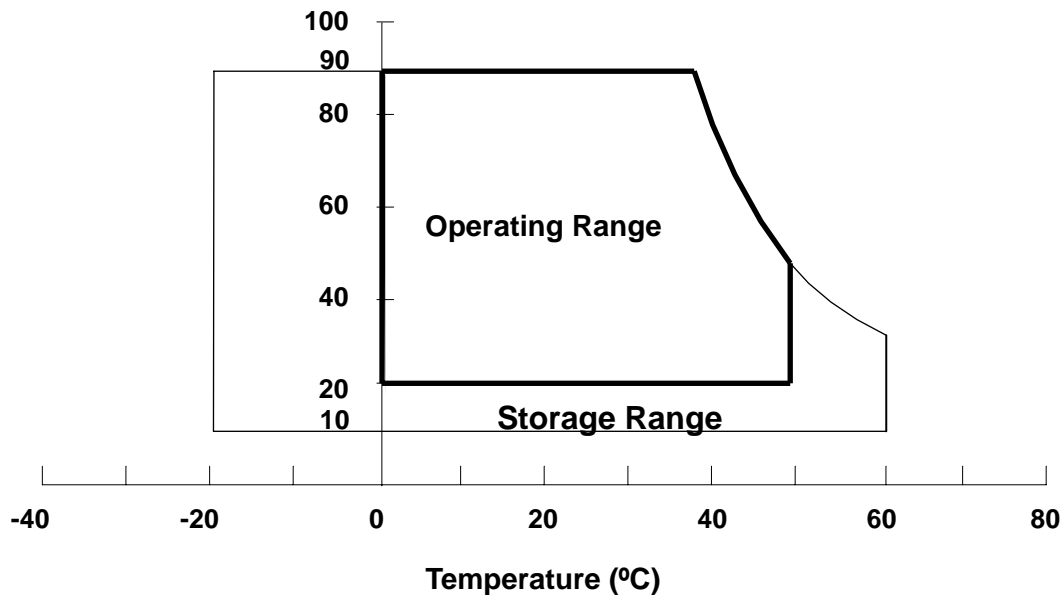

Note (3) 1 time for ± X, ± Y, ± Z. for Condition (200G / 2ms) is half Sine Wave,.

Note (4) 10 ~ 500 Hz, 30 min/cycle, 1 cycles for each X, Y, Z axis.

Note (5) At testing Vibration and Shock, the fixture in holding the module has to be hard and rigid enough so that the module would not be twisted or bent by the fixture.

The fixing condition is shown as below:

At Room Temperature

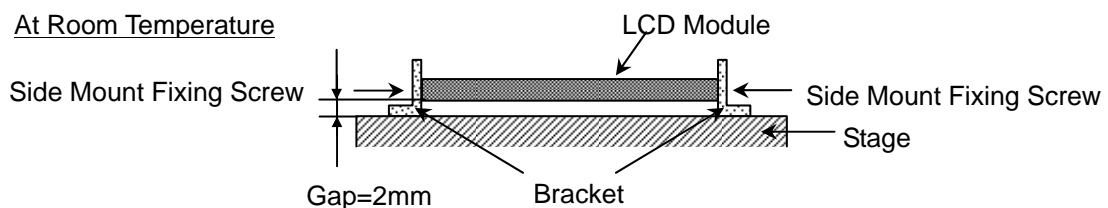

2.2 ELECTRICAL ABSOLUTE RATINGS

2.2.1 TFT LCD MODULE

Item	Symbol	Value		Unit	Note
		Min.	Max.		
Power Supply Voltage	V_{CC}	-0.3	+4.0	V	(1)
Logic Input Voltage	V_{IN}	-0.3	$V_{CC}+0.3$	V	

2.2.2 BACKLIGHT UNIT

Item	Value		Unit	Note
	Min	Max.		
LED Light Bar Input Voltage	30	34	V_{DC}	(1), (2)
LED Light Bar Input Current	114	150	mA_{DC}	
LED Peak Pulse Current	-	80	mA_{DC}	

Note (1) Permanent damage to the device may occur if maximum values are exceeded. Function operation should be restricted to the conditions described under Normal Operating Conditions.

Note (2) Specified values are for LED (Refer to Section 3.2 for further information).

3. ELECTRICAL CHARACTERISTICS

3.1 TFT LCD MODULE

Parameter	Symbol	Value			Unit	Note	
		Min.	Typ.	Max.			
Power Supply Voltage	V _{CC}	3.0	3.3	3.6	V	-	
Ripple Voltage	V _{RP}	-	50	-	mV	-	
Rush Current	I _{RUSH}	-	-	1.5	A	(2)	
Initial Stage Current	I _{IS}	-	-	1.0	A	(2)	
Power Supply Current	White	L _{CC}	-	240	290	mA	(3)a
	Black		-	350	400	mA	(3)b
LVDS Differential Input High Threshold	V _{TH(LVDS)}	-	-	+100	mV	(5), V _{CM} =1.2V	
LVDS Differential Input Low Threshold	V _{TL(LVDS)}	-100	-	-	mV	(5), V _{CM} =1.2V	
LVDS Common Mode Voltage	V _{CM}	1.125	-	1.375	V	(5)	
LVDS Differential Input Voltage	V _{ID}	100	-	600	mV	(5)	
Terminating Resistor	R _T	-	100	-	Ohm		
Power per EBL WG	P _{EBL}		1.90		W	(4)	

T_a = 25 ± 2 °C

Note (1) The module should be always operated within above ranges.

Note (2) I_{RUSH}: the maximum current when V_{CC} is rising

I_{IS}: the maximum current of the first 100ms after power-on

Measurement Conditions: Shown as the following figure. Test pattern: black.

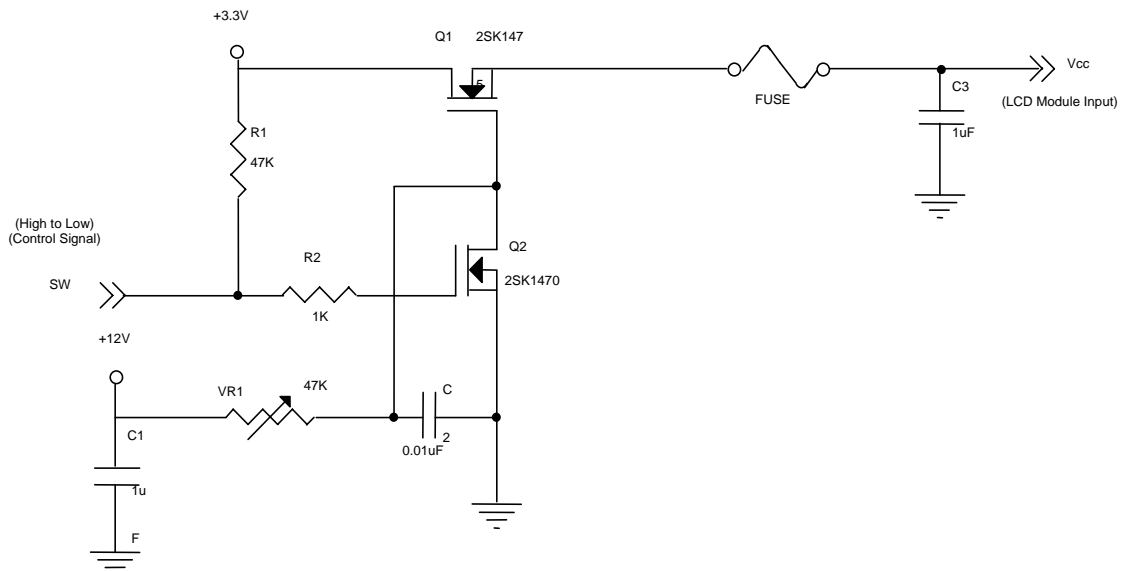

Vcc rising time is 470us

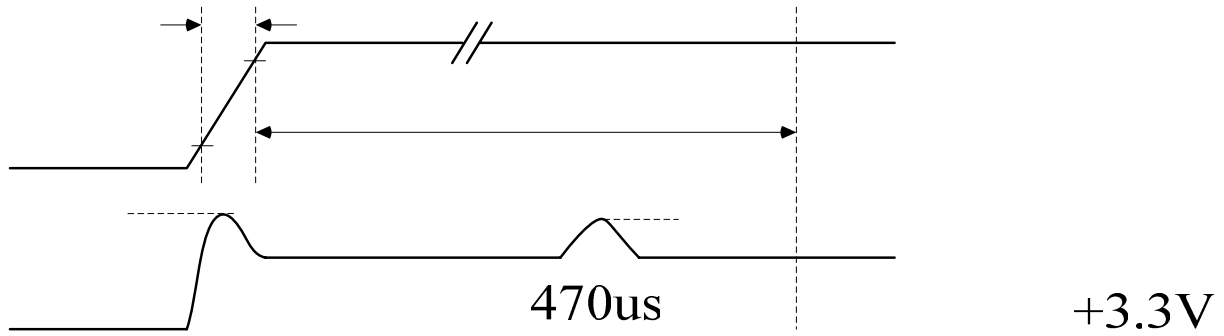

Note (3) The specified power supply current is under the conditions at $V_{cc} = 3.3\text{ V}$, $T_a = 25 \pm 2^\circ\text{C}$, $f_v = 60\text{ Hz}$, whereas a power dissipation check pattern below is displayed.

a. White Pattern



Active Area

0V

b. Black Pattern

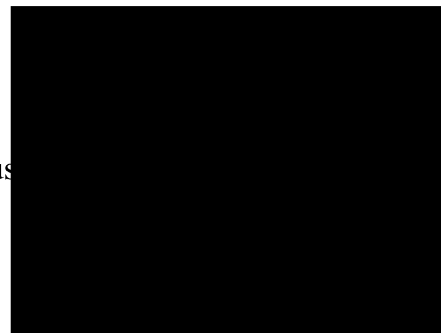

Active Area

0.1V_{cc}

I_{Rus}

Note (4) The specified power are the sum of LCD panel electronics input power and the inverter input power. Test conditions are as follows.

- (a) $V_{cc} = 3.3\text{ V}$, $T_a = 25 \pm 2^\circ\text{C}$, $f_v = 60\text{ Hz}$,
- (b) The pattern used is a black and white 32 x 36 checkerboard, slide #100 from the VESA file "Flat Panel Display Monitor Setup Patterns", FPDMSU.ppt.
- (c) Luminance: 60 nits.

Note (5) The parameters of LVDS signals are defined as the following figures.

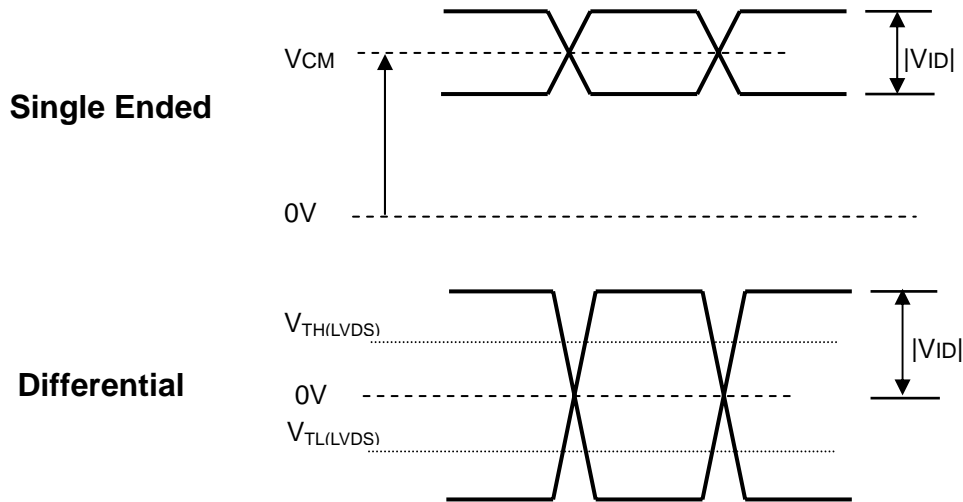

3.2 BACKLIGHT UNIT

Ta = 25 ± 2 °C

Parameter	Symbol	Value			Unit	Note
		Min.	Typ.	Max.		
LED light bar input voltage	V _O	30	32	34	V _{DC}	(1), (Duty 100%)
LED light bar input current	I _O	114	120	150	mA _{DC}	(1), (Duty 100%)
LED Current Peak	I _f	-	-	80	mA _{DC}	Per EA
Power Consumption	P _O	3.6	3.84	4.08	W	(2), I _L = 120 mA
LED Life Time	L _{LED}	10000	-	-	Hrs	(3)

Note (1) LED current is measured by utilizing a high frequency current meter as shown below:

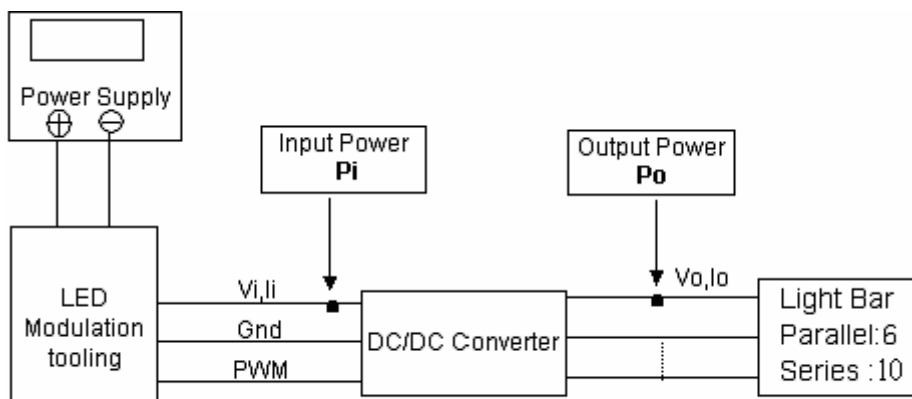

Note (2) P_O = I_O × V_O

Note (3) The lifetime of LED is defined as the time when it continues to operate under the conditions at Ta = 25 ± 2 °C and I = 20 mA(Per EA) until the brightness becomes ≤ 50% of its original value.

4. BLOCK DIAGRAM

4.1 TFT LCD MODULE

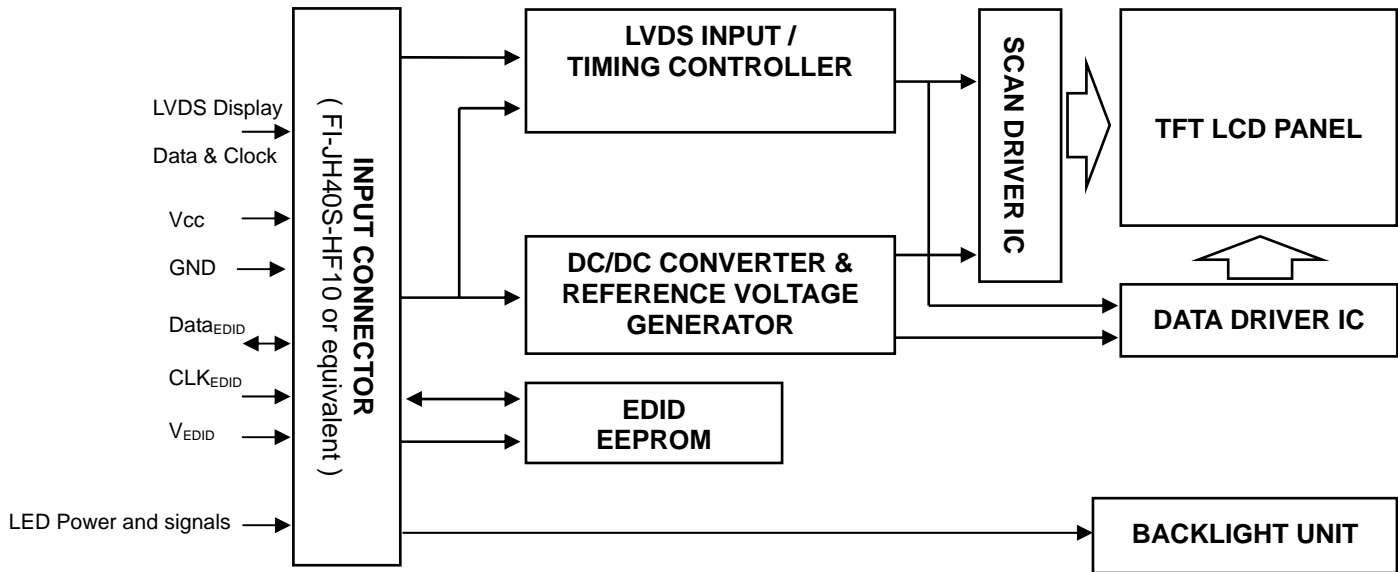

5. INPUT TERMINAL PIN ASSIGNMENT

5.1 TFT LCD MODULE

Pin	Symbol	Description	Polarity	Remark
1	V _{SS}	Ground		
2	V _{CC}	Power Supply +3.3 V (typical)		
3	V _{CC}	Power Supply +3.3 V (typical)		
4	V _{EDID}	DDC 3.3V Power		
5	V _{CC}	Power Supply +3.3 V (typical)		
6	CLK _{EDID}	DDC Clock		
7	DATA _{EDID}	DDC Data		
8	RXO0-	LVDS Differential Data Input (Odd)	Negative	
9	RXO0+	LVDS Differential Data Input (Odd)	Positive	
10	V _{SS}	Ground		
11	RXO1-	LVDS Differential Data Input (Odd)	Negative	
12	RXO1+	LVDS Differential Data Input (Odd)	Positive	
13	V _{SS}	Ground		
14	RXO2-	LVDS Differential Data Input (Odd)	Negative	
15	RXO2+	LVDS Differential Data Input (Odd)	Positive	
16	V _{SS}	Ground		
17	RXOC-	LVDS Clock Data Input (Odd)	Negative	
18	RXOC+	LVDS Clock Data Input (Odd)	Positive	
19	V _{SS}	Ground		
20	RxE0-	LVDS Differential Data Input (Even)	Negative	
21	RxE0+	LVDS Differential Data Input (Even)	Positive	
22	V _{SS}	Ground		
23	RxE1-	LVDS Differential Data Input (Even)	Negative	
24	RxE1+	LVDS Differential Data Input (Even)	Positive	
25	V _{SS}	Ground		
26	RxE2-	LVDS Differential Data Input (Even)	Negative	
27	RxE2+	LVDS Differential Data Input (Even)	Positive	
28	V _{SS}	Ground		
29	RXEC-	LVDS Clock Data Input (Even)	Negative	
30	RXEC+	LVDS Clock Data Input (Even)	Positive	
31	VFB1	LED Cathode (Negative)		
32	VFB2	LED Cathode (Negative)		
33	VFB3	LED Cathode (Negative)		
34	VFB4	LED Cathode (Negative)		
35	VFB5	LED Cathode (Negative)		
36	VFB6	LED Cathode (Negative)		
37	NC	Non-Connection		
38	V _{dc}	LED Annode (Positive)		
39	V _{dc}	LED Annode (Positive)		
40	V _{dc}	LED Annode (Positive)		

Note (1) Connector Part No.: FI-JH40S-HF10 or equivalent

Note (2) User's connector Part No: FI-JH40C or equivalent

Note (3) The first pixel is odd as shown in the following figure.

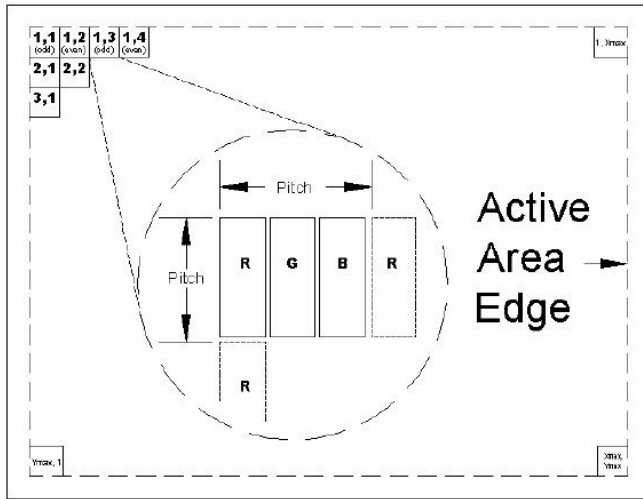

5.2 TIMING DIAGRAM OF LVDS INPUT SIGNAL

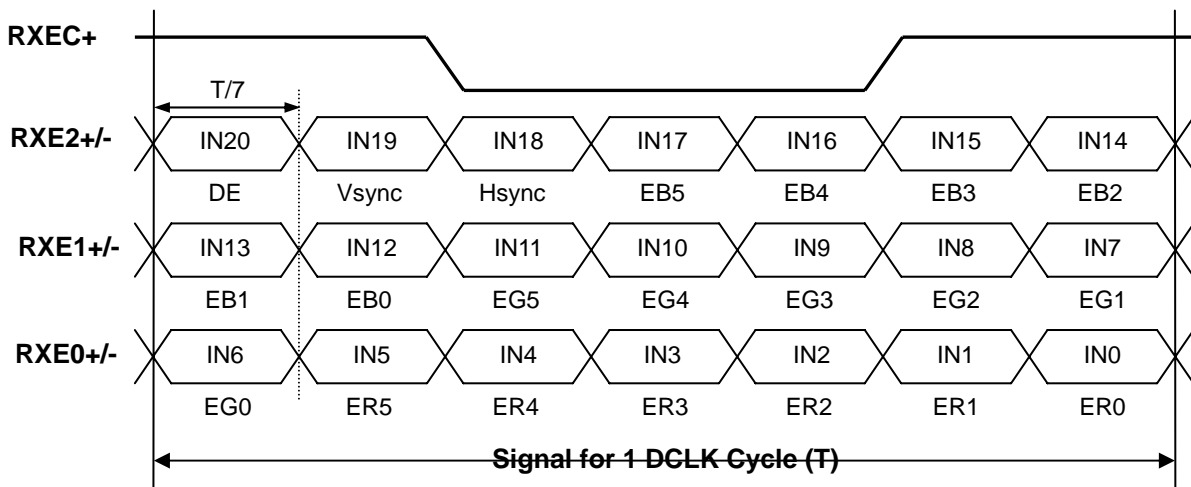
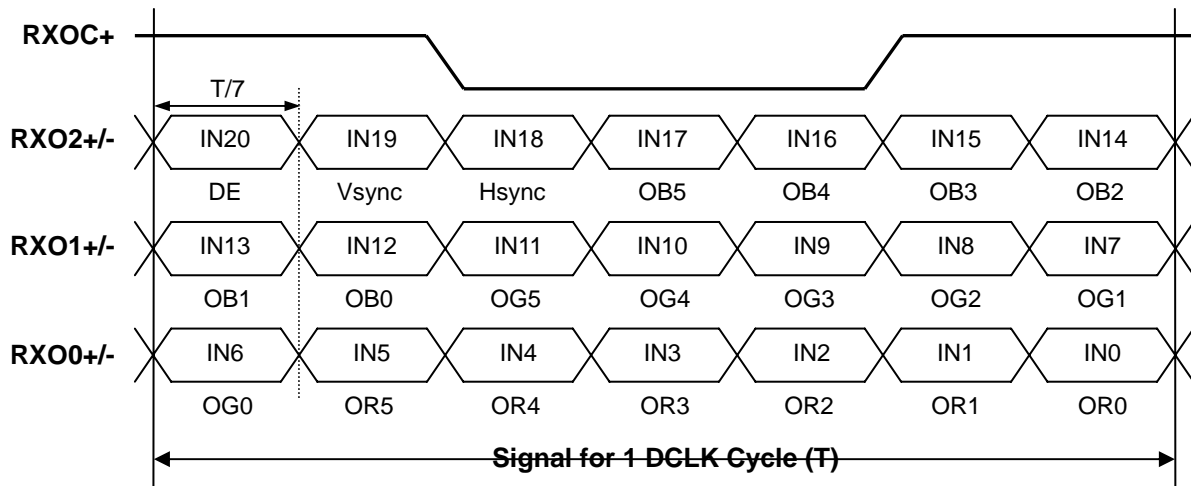

5.3 COLOR DATA INPUT ASSIGNMENT

The brightness of each primary color (red, green and blue) is based on the 6-bit gray scale data input for the color. The higher the binary input, the brighter the color. The table below provides the assignment of color versus data input.

Color		Data Signal																	
		Red						Green						Blue					
		R5	R4	R3	R2	R1	R0	G5	G4	G3	G2	G1	G0	B5	B4	B3	B2	B1	B0
Basic Colors	Black	0	0	0	0	0	0	0	0	0	0	0	0	0	0	0	0	0	0
	Red	1	1	1	1	1	1	0	0	0	0	0	0	0	0	0	0	0	0
	Green	0	0	0	0	0	0	1	1	1	1	1	1	0	0	0	0	0	0
	Blue	0	0	0	0	0	0	0	0	0	0	0	0	1	1	1	1	1	1
	Cyan	0	0	0	0	0	0	1	1	1	1	1	1	1	1	1	1	1	1
	Magenta	1	1	1	1	1	1	0	0	0	0	0	0	1	1	1	1	1	1
	Yellow	1	1	1	1	1	1	1	1	1	1	1	1	0	0	0	0	0	0
	White	1	1	1	1	1	1	1	1	1	1	1	1	1	1	1	1	1	1
Gray Scale Of Red	Red(0)/Dark	0	0	0	0	0	0	0	0	0	0	0	0	0	0	0	0	0	0
	Red(1)	0	0	0	0	0	1	0	0	0	0	0	0	0	0	0	0	0	0
	Red(2)	0	0	0	0	1	0	0	0	0	0	0	0	0	0	0	0	0	0
	:	:	:	:	:	:	:	:	:	:	:	:	:	:	:	:	:	:	:
	:	:	:	:	:	:	:	:	:	:	:	:	:	:	:	:	:	:	:
	:	:	:	:	:	:	:	:	:	:	:	:	:	:	:	:	:	:	:
	Red(61)	1	1	1	1	0	1	0	0	0	0	0	0	0	0	0	0	0	0
	Red(62)	1	1	1	1	1	0	0	0	0	0	0	0	0	0	0	0	0	0
Red(63)	1	1	1	1	1	1	0	0	0	0	0	0	0	0	0	0	0	0	
Gray Scale Of Green	Green(0)/Dark	0	0	0	0	0	0	0	0	0	0	0	0	0	0	0	0	0	0
	Green(1)	0	0	0	0	0	0	0	0	0	0	0	1	0	0	0	0	0	0
	Green(2)	0	0	0	0	0	0	0	0	0	0	1	0	0	0	0	0	0	0
	:	:	:	:	:	:	:	:	:	:	:	:	:	:	:	:	:	:	:
	:	:	:	:	:	:	:	:	:	:	:	:	:	:	:	:	:	:	:
	:	:	:	:	:	:	:	:	:	:	:	:	:	:	:	:	:	:	:
	Green(61)	0	0	0	0	0	0	1	1	1	1	0	1	0	0	0	0	0	0
	Green(62)	0	0	0	0	0	0	1	1	1	1	1	0	0	0	0	0	0	0
Green(63)	0	0	0	0	0	0	1	1	1	1	1	1	0	0	0	0	0	0	
Gray Scale Of Blue	Blue(0)/Dark	0	0	0	0	0	0	0	0	0	0	0	0	0	0	0	0	0	0
	Blue(1)	0	0	0	0	0	0	0	0	0	0	0	0	0	0	0	0	0	1
	Blue(2)	0	0	0	0	0	0	0	0	0	0	0	0	0	0	0	0	1	0
	:	:	:	:	:	:	:	:	:	:	:	:	:	:	:	:	:	:	:
	:	:	:	:	:	:	:	:	:	:	:	:	:	:	:	:	:	:	:
	:	:	:	:	:	:	:	:	:	:	:	:	:	:	:	:	:	:	:
	Blue(61)	0	0	0	0	0	0	0	0	0	0	0	0	1	1	1	1	0	1
	Blue(62)	0	0	0	0	0	0	0	0	0	0	0	0	1	1	1	1	1	0
Blue(63)	0	0	0	0	0	0	0	0	0	0	0	0	1	1	1	1	1	1	

Note (1) 0: Low Level Voltage, 1: High Level Voltage

5.4 EDID DATA STRUCTURE

The EDID (Extended Display Identification Data) data formats are to support displays as defined in the VESA Plug & Display and FPD standards.

Byte # (decimal)	Byte # (hex)	Field Name and Comments	Value (hex)	Value (binary)
0	0	Header	00	00000000
1	1	Header	FF	11111111
2	2	Header	FF	11111111
3	3	Header	FF	11111111
4	4	Header	FF	11111111
5	5	Header	FF	11111111
6	6	Header	FF	11111111
7	7	Header	00	00000000
8	8	EISA ID manufacturer name ("APP")	06	00000110
9	9	EISA ID manufacturer name (Compressed ASCII)	10	00010000
10	0A	ID product code (N154C6-L01)	6D	01101101
11	0B	ID product code (hex LSB first; N154C6-L01)	9C	10011100
12	0C	ID S/N (fixed "0")	00	00000000
13	0D	ID S/N (fixed "0")	00	00000000
14	0E	ID S/N (fixed "0")	00	00000000
15	0F	ID S/N (fixed "0")	00	00000000
16	10	Week of manufacture (fixed "27")	1B	00011011
17	11	Year of manufacture (fixed "2007")	11	00010001
18	12	EDID structure version # ("1")	01	00000001
19	13	EDID revision # ("3")	03	00000011
20	14	Video I/P definition ("digital")	80	10000000
21	15	Max H image size ("34.4cm")	22	00100010
22	16	Max V image size ("22.2cm")	16	00010110
23	17	Display Gamma (Gamma = "2.2")	78	01111000
24	18	Feature support ("Active off, RGB Color")	0A	00001010
25	19	Red/Green (Rx1, Rx0, Ry1, Ry0, Gx1, Gx0, Gy1, Gy0)	5C	01011100
26	1A	Blue/White (Bx1, Bx0, By1, By0, Wx1, Wx0, Wy1, Wy0)	20	00100000
27	1B	Red-x (Rx = "0.595")	98	10011000
28	1C	Red-y (Ry = "0.345")	58	01011000
29	1D	Green-x (Gx = "0.320")	51	01010001
30	1E	Green-y (Gy = "0.555")	8E	10001110
31	1F	Blue-x (Bx = "0.155")	27	00100111
32	20	Blue-y (By = "0.145")	25	00100101
33	21	White-x (Wx = "0.313")	50	01010000
34	22	White-y (Wy = "0.329")	54	01010100
35	23	Established timings 1	00	00000000
36	24	Established timings 2 (1440x900@60Hz)	00	00000000
37	25	Manufacturer's reserved timings	00	00000000
38	26	Standard timing ID # 1	01	00000001
39	27	Standard timing ID # 1	01	00000001
40	28	Standard timing ID # 2	01	00000001
41	29	Standard timing ID # 2	01	00000001

42	2A	Standard timing ID # 3	01	00000001
43	2B	Standard timing ID # 3	01	00000001
44	2C	Standard timing ID # 4	01	00000001
45	2D	Standard timing ID # 4	01	00000001
46	2E	Standard timing ID # 5	01	00000001
47	2F	Standard timing ID # 5	01	00000001
48	30	Standard timing ID # 6	01	00000001
49	31	Standard timing ID # 6	01	00000001
50	32	Standard timing ID # 7	01	00000001
51	33	Standard timing ID # 7	01	00000001
52	34	Standard timing ID # 8	01	00000001
53	35	Standard timing ID # 8	01	00000001
54	36	Detailed timing/monitor	9F	10011111
55	37	1440x900 @60Hz : Pixel Clock = 96.31 MHz	25	00100101
56	38	Hor active=1440 pixels	A0	10100000
57	39	Hor blanking=320 pixels	40	01000000
58	3A		51	01010001
59	3B	Vertical active=900 lines	84	10000100
60	3C	Vertical blanking=12lines	0C	00001100
61	3D		30	00110000
62	3E	H sync. Offset=64 pixels	40	01000000
63	3F	H sync. Width=32 pixels	20	00100000
64	40	V sync. Offset=3 lines	33	00110011
65	41	V sync. Width=3 lines	00	00000000
66	42	H image size= 331.56mm	21	00100001
67	43	V image size = 207.23 mm	15	00010101
68	44		10	00010000
69	45	No Horizontal Border	00	00000000
70	46	No Vertical Border	00	00000000
71	47	Non-interlaced, Normal display, No stereo, Digital separate sync, H/V pol Negatives	19	00011001
72	48	Detailed timing/monitor	00	00000000
73	49	descriptor #2	00	00000000
74	4A		00	00000000
75	4B		01	00000001
76	4C	Version	00	00000000
77	4D	Apple edid signature	06	00000110
78	4E	Apple edid signature	10	00010000
79	4F	Link Type (LVDS Link,MSB justified)	30	00110000
80	50	Pixel and link component format (6-bit panel interface)	00	00000000
81	51	Panel features (No inverter)	00	00000000
82	52		00	00000000
83	53		00	00000000
84	54		00	00000000
85	55		00	00000000
86	56		00	00000000
87	57		00	00000000

88	58		0A	00001010
89	59		20	00100000
90	5A	Detailed timing description # 3	00	00000000
91	5B	# 3 Flag	00	00000000
92	5C	# 3 Reserved	00	00000000
93	5D	# 3 FE (hex) defines ASCII string (Model Name"N154C1-L01", ASCII)	FE	11111110
94	5E	# 3 Flag	00	00000000
95	5F	# 3 1st character of name ("N")	4E	01001110
96	60	# 3 2nd character of name ("1")	31	00110001
97	61	# 3 3rd character of name ("5")	35	00110101
98	62	# 3 4th character of name ("4")	34	00110100
99	63	# 3 5th character of name ("C")	43	01000011
100	64	# 3 6th character of name ("6")	36	00110110
101	65	# 3 7th character of name ("-")	2D	00101101
102	66	# 3 8th character of name ("L")	4C	01001100
103	67	# 3 9th character of name ("0")	30	00110000
104	68	# 3 9th character of name ("1")	31	00110001
105	69	# 3 New line character indicates end of ASCII string	0A	00001010
106	6A	# 3 Padding with "Blank" character	20	00100000
107	6B	# 3 Padding with "Blank" character	20	00100000
108	6C	Detailed timing description # 4	00	00000000
109	6D	# 4 Flag	00	00000000
110	6E	# 4 Reserved	00	00000000
111	6F	# 4 FC (hex) defines Monitor name ("Color LCD", ASCII)	FC	11111100
112	70	# 4 Flag	00	00000000
113	71	# 4 1st character of name ("C")	43	01000011
114	72	# 4 2nd character of name ("o")	6F	01101111
115	73	# 4 3rd character of name ("l")	6C	01101100
116	74	# 4 4th character of name ("o")	6F	01101111
117	75	# 4 5th character of name ("r")	72	01110010
118	76	# 4 6th character of name (<space>)	20	00100000
119	77	# 4 7th character of name ("L")	4C	01001100
120	78	# 4 8th character of name ("C")	43	01000011
121	79	# 4 9th character of name ("D")	44	01000100
122	7A	# 4 New line character # 4 indicates end of Monitor name	0A	00001010
123	7B	# 4 Padding with "Blank" character	20	00100000
124	7C	# 4 Padding with "Blank" character	20	00100000
125	7D	# 4 Padding with "Blank" character	20	00100000
126	7E	Extension flag	00	00000000
127	7F	Checksum	3F	00111111

6. INTERFACE TIMING

6.1 INPUT SIGNAL TIMING SPECIFICATIONS

The input signal timing specifications are shown as the following table and timing diagram.

Signal	Item	Symbol	Min.	Typ.	Max.	Unit	Note
DCLK	Frequency	1/Tc	25	44.5	60	MHz	(2)
DE	Vertical Total Time	TV	910	926	1500	TH	-
	Vertical Active Display Period	TVD	900	900	900	TH	-
	Vertical Active Blanking Period	TVB	TV-TVD	26	TV-TVD	TH	
	Horizontal Total Time	TH	760	800	880	Tc	(2)
	Horizontal Active Display Period	THD	720	720	720	Tc	(2)
	Horizontal Active Blanking Period	THB	TH-THD	80	TH-THD	Tc	(2)

Note (1) Because this module is operated by DE only mode, Hsync and Vsync are ignored.

(2) 2 channels LVDS input.

INPUT SIGNAL TIMING DIAGRAM

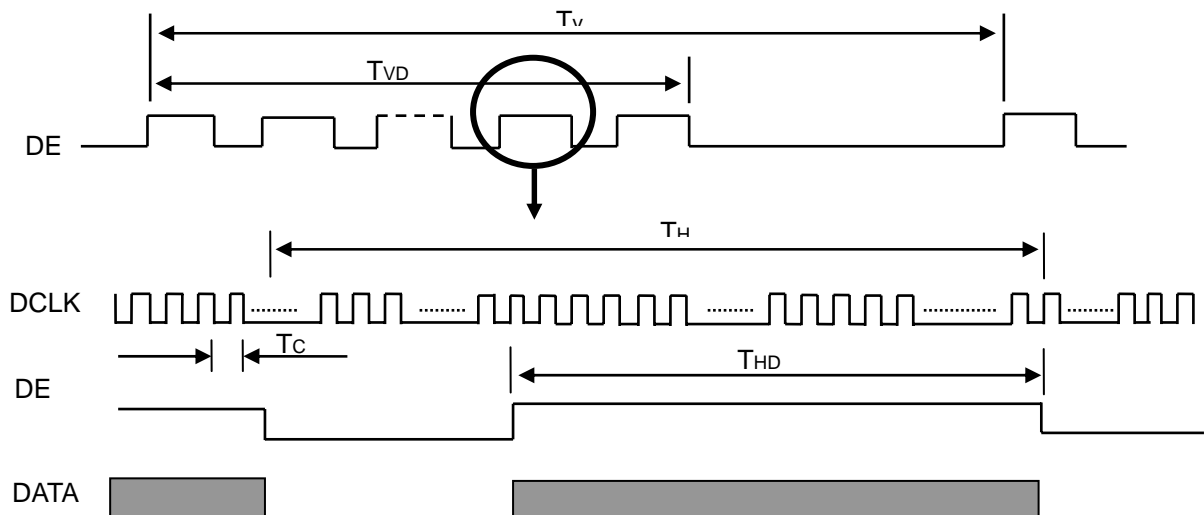

6.2 POWER ON/OFF SEQUENCE

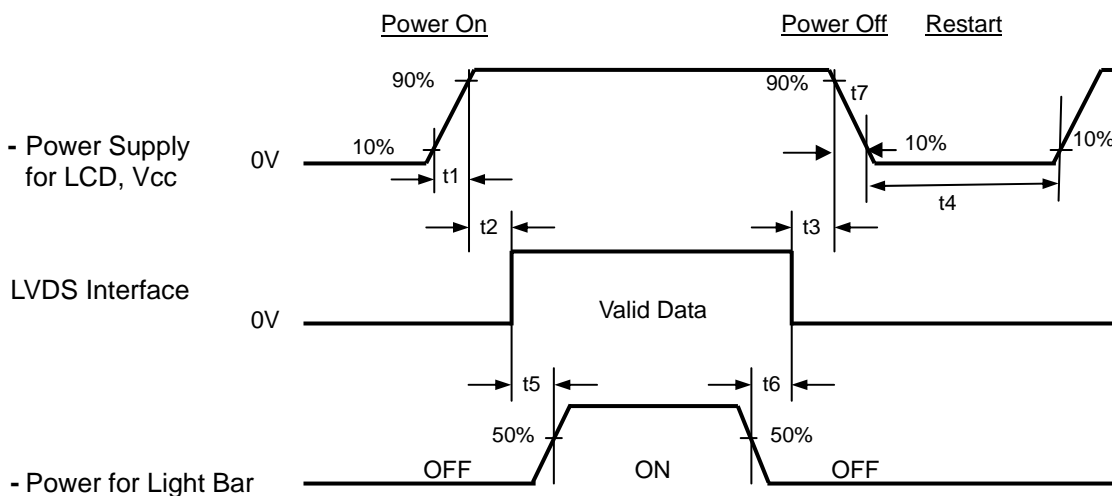

Timing Specifications:

- $470\mu\text{s} < t_1 \leq 10 \text{ ms}$
- $0 < t_2 \leq 50 \text{ ms}$
- $0 < t_3 \leq 50 \text{ ms}$
- $t_4 \geq 500 \text{ ms}$
- $t_5 \geq 200 \text{ ms}$
- $t_6 \geq 200 \text{ ms}$

Note (1) Please follow the power on/off sequence described above. Otherwise, the LCD module might be damaged.

Note (2) Please avoid floating state of interface signal at invalid period. When the interface signal is invalid, be sure to pull down the power supply of LCD Vcc to 0 V.

Note (3) The Backlight inverter power must be turned on after the power supply for the logic and the interface signal is valid. The Backlight inverter power must be turned off before the power supply for the logic and the interface signal is invalid.

Note (4) Sometimes some slight noise shows when LCD is turned off (even backlight is already off). To avoid this phenomenon, we suggest that the Vcc falling time is better to follow $5 \leq t_7 \leq 300 \text{ ms}$.

7. OPTICAL CHARACTERISTICS

7.1 TEST CONDITIONS

Item	Symbol	Value	Unit
Ambient Temperature	T _a	25±2	°C
Ambient Humidity	H _a	50±10	%RH
Supply Voltage	V _{CC}	3.3	V
Input Signal	According to typical value in "3. ELECTRICAL CHARACTERISTICS"		
LED Light Bar Input Current	I _L	120	mA

7.2 OPTICAL SPECIFICATIONS

Item		Symbol	Condition	Min.	Typ.	Max.	Unit	Note			
Contrast Ratio		CR	θ _x =0°, θ _y =0° Viewing Normal Angle	400	500		-	(2), (5)			
Response Time		T _R		-	3	8	ms	(3)			
		T _F		-	7	12	ms				
Center Luminance of White		L _{ct}		279	316		cd/m ²	(4), (5)			
Luminance Uniformity		U				50	%	(5), (8)			
Color Chromaticity	Red	R _x		θ _x =0°, θ _y =0° Viewing Normal Angle	TYP -0.03	0.595	TYP +0.03	-	(5)		
		R _y				0.345		-			
	Green	G _x				0.320		-			
		G _y				0.555		-			
	Blue	B _x				0.155		-			
		B _y				0.145		-			
	White	W _x				0.305		0.313		0.321	-
		W _y				0.317		0.330		0.343	-
Cross-talk		D _{SHA}		-	-	4	%	(5), (6)			
Color Difference w.r.t. center			-	-	0.012	-	(5), (9)				
Color Difference over panel			-	-	0.0155	-	(5), (10)				
Color Difference worst neighbor			-	-	0.0035	-	(5), (11)				
Viewing Angle	Horizontal	θ _{x+}	CR≥10	65	75		Deg.	(1)			
		θ _{x-}		65	75						
	Vertical	θ _{y+}		65	75						
		θ _{y-}		60	70						

Note (1) Definition of Viewing Angle (θ_x, θ_y):

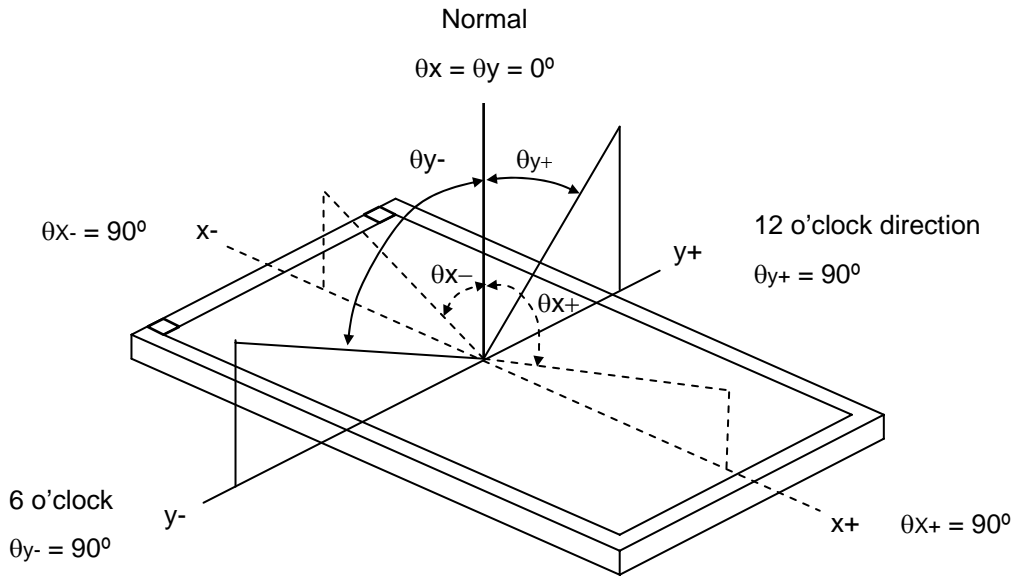

Note (2) Definition of Contrast Ratio (CR):

The contrast ratio can be calculated by the following expression.

$$\text{Contrast Ratio (CR)} = L_{63} / L_0$$

L_{63} : Luminance of gray level 63

L_0 : Luminance of gray level 0

$$CR = CR(5)$$

CR (X) is corresponding to the Contrast Ratio of the point X at Figure in Note (7).

Note (3) Definition of Response Time (T_R, T_F):

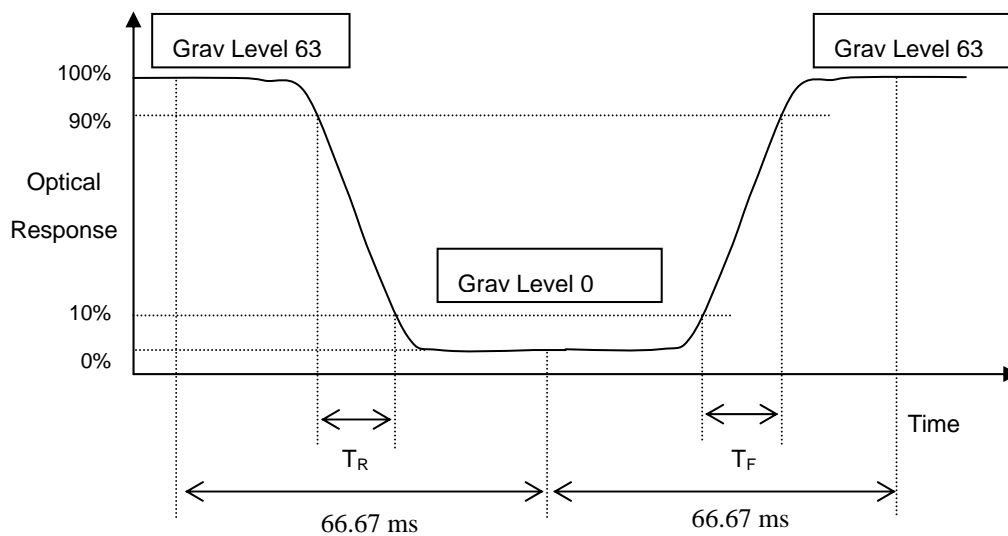

Note (4) Definition of Center Luminance of White (L_{ct}):

Measure the luminance of gray level 63 at center points

$$L_{ct} = L(5)$$

$L(x)$ is corresponding to the luminance of the point X at Figure in Note (7).

Note (5) Measurement Setup:

The LCD module should be stabilized at given temperature for 15 minutes to avoid abrupt temperature change during measuring. In order to stabilize the luminance, the measurement should be executed after lighting Backlight for 15 minutes in a windless room.

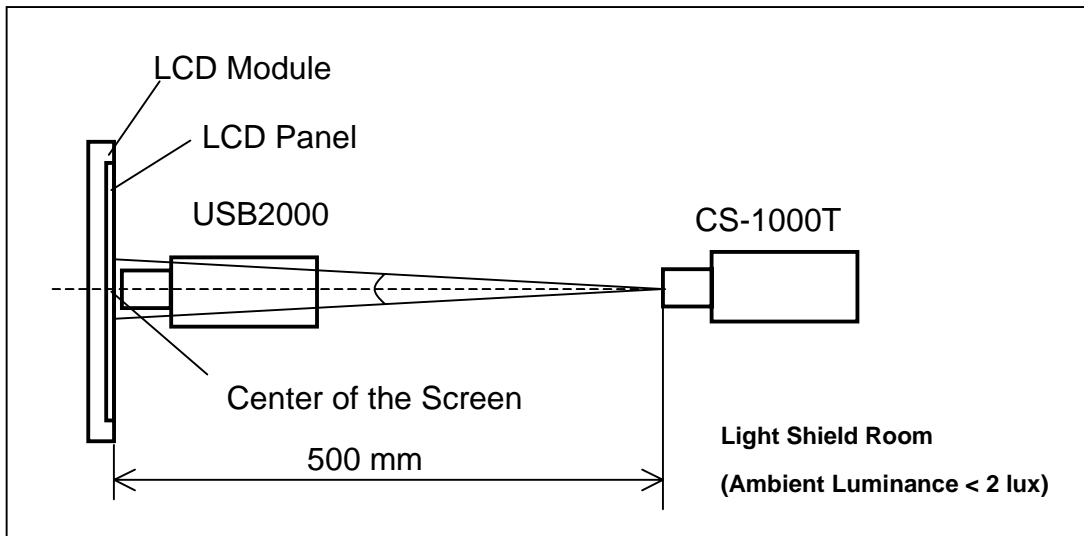

Note (6) Definition of Cross-talk (D_{SHA})

$$D_{SHA} = |Y_B - Y_A| / Y_A \times 100 (\%)$$

Where:

Y_A = Luminance of measured location without gray level 0 pattern (cd/m^2)

Y_B = Luminance of measured location with gray level 0 pattern (cd/m^2)

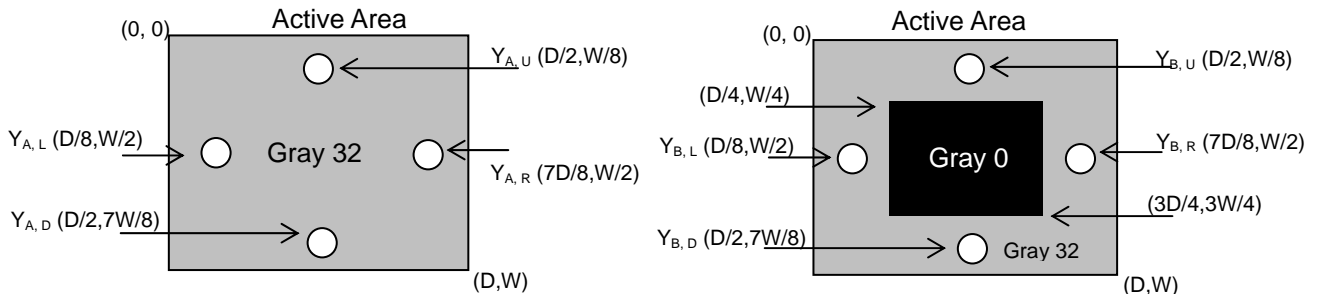

Note (7) Definition of measure point

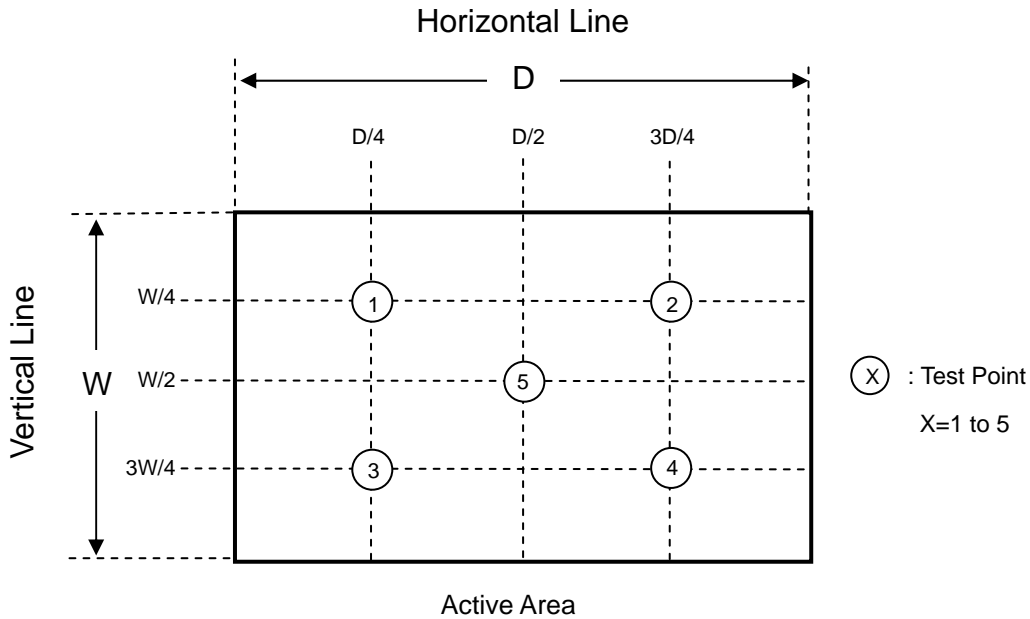

Note (8) Definition of Luminance Uniformity(U)

$$U = L_{min}/L_{max}$$

Where:

$L_{max} = \max \{ \text{Luminance values at 160 points} \}$,

$L_{min} = \min \{ \text{Luminance values at 160 points} \}$

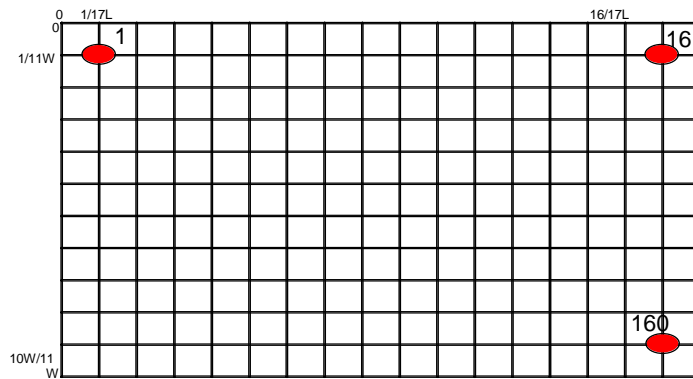

Note (9) Definition of Color Difference with respect to the center

Center color coordinate is defined as the Average of points of 72, 73, 88, 89. where is corresponding to the measured point in Note (8)

$$\text{Color Difference} = [(u'_x - u'_c)^2 + (v'_x - v'_c)^2]^{1/2}$$

Where x is any point in Note (8), c is the center point.

Note (10) Definition of Color Difference over the panel

Color Difference between any two measured points over the 160 points

$$=[(u'_x - u'_y)^2 + (v'_x - v'_y)^2]^{1/2}$$

Where x, y is any two points in Note (8)

Note (11) Definition of Color Difference between two neighbor

Color Difference between any two neighboring points on the panel

$$=[(u'_x - u'_y)^2 + (v'_x - v'_y)^2]^{1/2}$$

Where x, y is any two neighbor points in Note (8)

8. PRECAUTIONS

8.1 HANDLING PRECAUTIONS

- (1) The module should be assembled into the system firmly by using every mounting hole. Be careful not to twist or bend the module.
- (2) While assembling or installing modules, it can only be in the clean area. The dust and oil may cause electrical short or damage the polarizer.
- (3) Use fingerstalls or soft gloves in order to keep display clean during the incoming inspection and assembly process.
- (4) Do not press or scratch the surface harder than a HB pencil lead on the panel because the polarizer is very soft and easily scratched.
- (5) If the surface of the polarizer is dirty, please clean it by some absorbent cotton or soft cloth. Do not use Ketone type materials (ex. Acetone), Ethyl alcohol, Toluene, Ethyl acid or Methyl chloride. It might permanently damage the polarizer due to chemical reaction.
- (6) Wipe off water droplets or oil immediately. Staining and discoloration may occur if they left on panel for a long time.
- (7) If the liquid crystal material leaks from the panel, it should be kept away from the eyes or mouth. In case of contacting with hands, legs or clothes, it must be washed away thoroughly with soap.
- (8) Protect the module from static electricity, it may cause damage to the C-MOS Gate Array IC.
- (9) Do not disassemble the module.
- (10) Pins of I/F connector should not be touched directly with bare hands.

8.2 STORAGE PRECAUTIONS

- (1) High temperature or humidity may reduce the performance of module. Please store LCD module within the specified storage conditions.
- (2) It is dangerous that moisture come into or contacted the LCD module, because the moisture may damage LCD module when it is operating.

8.3 OPERATION PRECAUTIONS

- (1) Do not pull the I/F connector in or out while the module is operating.
- (2) Always follow the correct power on/off sequence when LCD module is connecting and operating. This can prevent the CMOS LSI chips from damage during latch-up.
- (3) The startup voltage of Backlight is approximately 1000 Volts. It may cause electrical shock while assembling with inverter. Do not disassemble the module or insert anything into the Backlight unit.

9. PACKING

9.1 CARTON

Box Dimensions : 435(L)*350(W)*325(H)
 Weight: Approx. 13.06kg(20 module .per. 1 box)

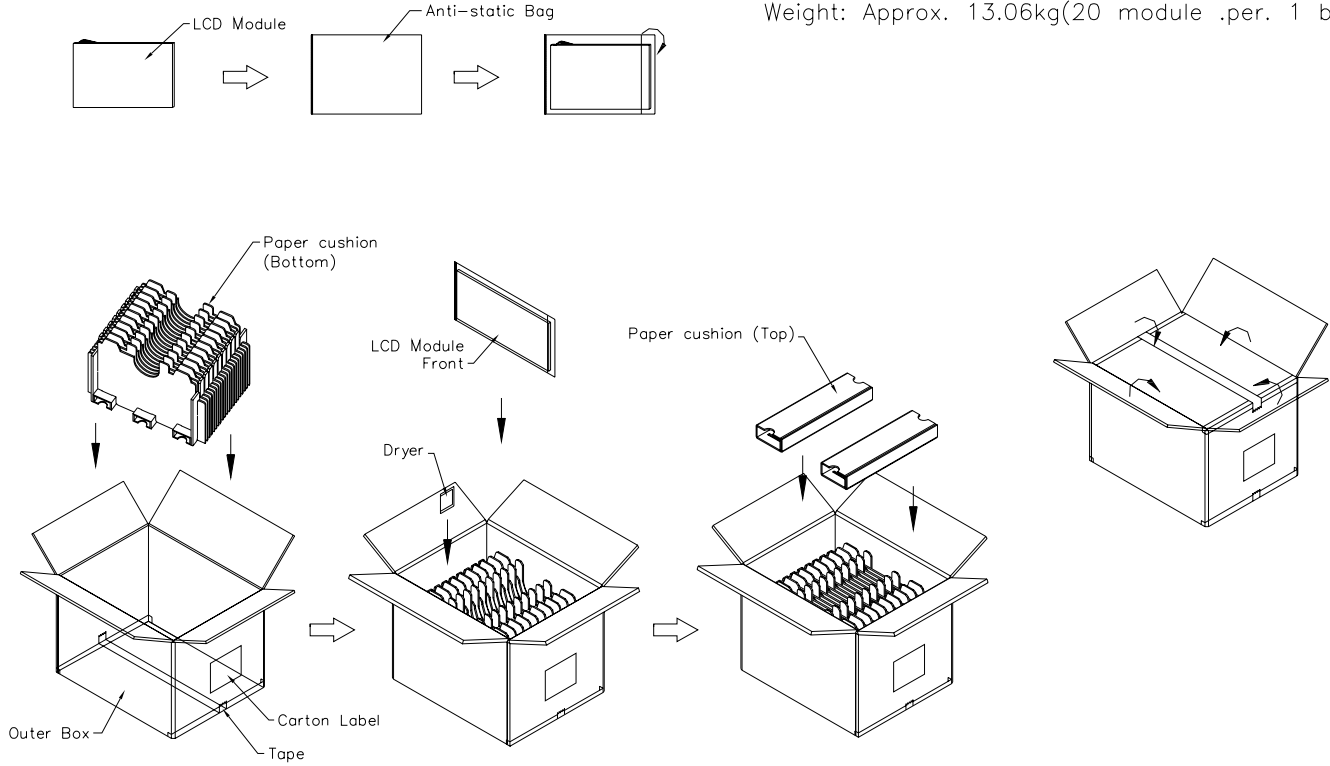
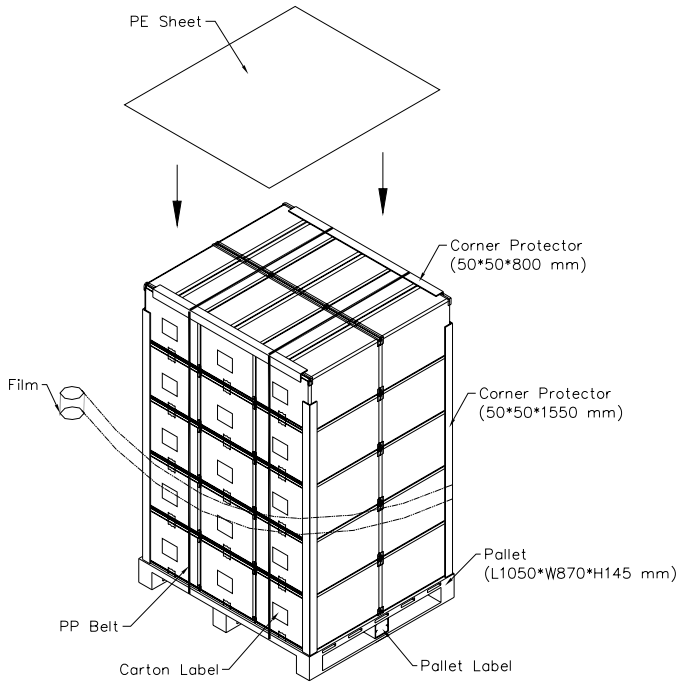

Figure. 9-1 Packing method

9.2 PALLET

Sea & Land Transportation



Air Transportation

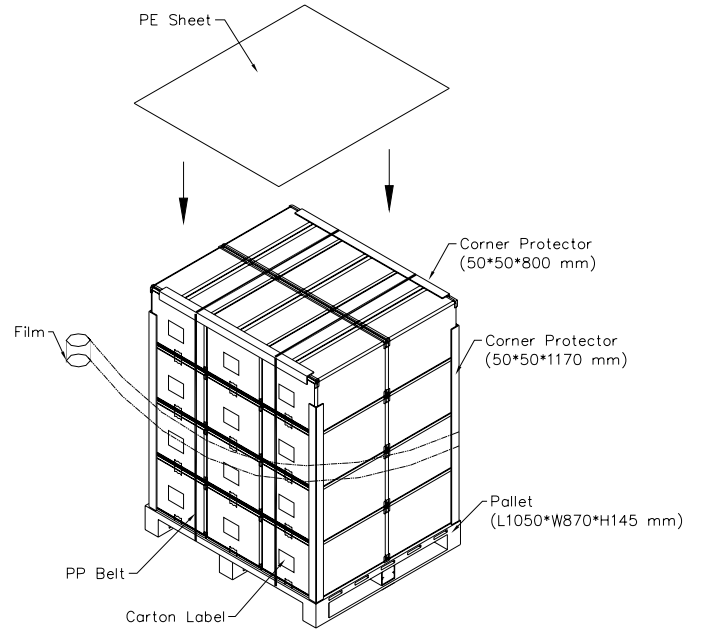

Figure. 9-2 Packing method

10 DEFINITION OF LABELS

10.1 CMO MODULE LABEL

The barcode nameplate is pasted on each module as illustration, and its definitions are as following explanation.



(a) Model Name: N154C6 - L02

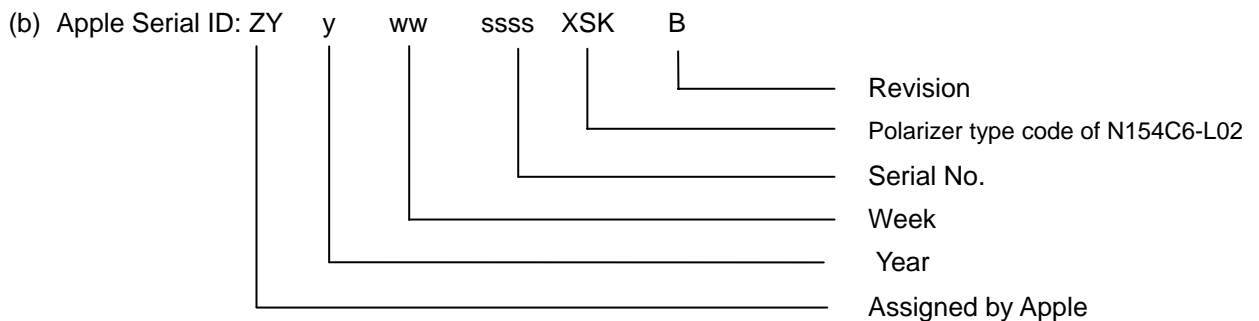

(c) Production Location: MADE IN XXXX. XXXX stands for production location.

(d) UL logo: LEOO especially stands for panel manufactured by CMO NingBo satisfying UL requirement.
 The panel without LEOO mark stands for manufactured by CMO Taiwan satisfying UL requirement.

(e) Revision: Rev. XX, for example: A1, ..., C1, C2 ...etc.

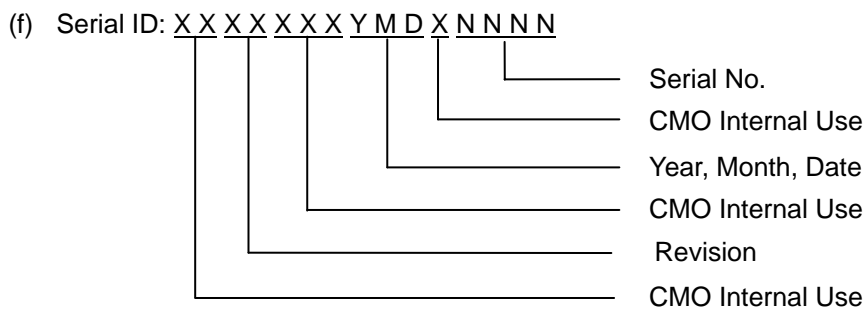

Serial ID includes the information as below:

(a) Manufactured Date: Year: 1~9, for 2001~2009

Month: 1~9, A~C, for Jan. ~ Dec.

Day: 1~9, A~Y, for 1st to 31st, exclude I, O and U

Revision Code: cover all the change

Day: 1~9, A~Y, for 1st to 31st, exclude I, O and U

(b) Revision Code: cover all the change

(c) Serial No.: Manufacturing sequence of product

10.2 CARTON LABEL



The image shows a template for a carton label. It features the CHI MEI logo and company name at the top left. Below this, there are four horizontal lines for text entry, labeled 'P.O.NO.', 'Part ID.', 'Model Name', and 'Carton ID.'. To the right of the 'Carton ID.' line is the word 'Quantities' followed by another horizontal line. At the bottom left, it says 'Made in XXXX'. At the bottom right, there is a yellow circular logo with 'GP' inside and the text 'RoHS' below it.

(a) Production location: Made In XXXX. XXXX stands for production location.