



MICROMINIATURE – COTS MICRO-D CONNECTORS

HDM01 THRU 04 – PRE-WIRED AND SOLDER CUP TERMINATIONS

HIRELCO PART NUMBER CODE

HDM 0* - * * * * *

HIRELCO CONNECTOR SERIES

HDM - MICRO D-SUBMINIATURE
(DESIGNS BASED ON M83513)

CONNECTOR TYPE, GENDER, & TERMINATION

01 - METAL SHELL PLUG, SOLDER CUP <1>
02 - METAL SHELL RECEPTACLE, SOLDER CUP <1>
03 - METAL SHELL PLUG, PRE-WIRED
04 - METAL SHELL RECEPTACLE, PRE-WIRED

CONNECTOR SIZE

(NUMBER OF CONTACTS) <2>

A=9, B=15, C=21, D=25, E=31, F=37, G=51, & H=100

WIRE TYPE & SIZE (AWG)

OMIT FOR SOLDER CUP CONTACTS

STRANDED & INSULATED:

A - MIL-W-22759/11-24 (24 AWG, 19-STRD)
B - MIL-W-22759/32-24 (24 AWG, 19-STRD)
C - MIL-W-22759/33-24 (24 AWG, 19-STRD)
D - MIL-W-16878/4-*** (26 AWG, 7-STRD)
E - MIL-W-16878/4-*** (26 AWG, 19-STRD)
F - MIL-W-22759/11-26 (26 AWG, 19-STRD)
G - MIL-W-22759/32-26 (26 AWG, 19-STRD)
H - MIL-W-22759/33-26 (26 AWG, 19-STRD)
J - 0407-26A-* (26 AWG LOW-OUTGASSING/SPACE)
K - MIL-W-16878/4-BCB* (28 AWG, 19-STRD)
L - MIL-W-22759/32-28 (28 AWG, 19-STRD)
M - MIL-W-22759/33-28 (28 AWG, 7-STRD)

SOLID & UNINSULATED:

5 - TIN PLATED 25 AWG, SOLID, UNINSULATED PER QQ-W-343
6 - TIN PLATED 24 AWG, SOLID, UNINSULATED PER QQ-W-343
7 - GOLD PLATED 25 AWG, SOLID, UNINSULATED PER QQ-W-343
8 - GOLD PLATED 24 AWG, SOLID, UNINSULATED PER QQ-W-343

WIRE COLOR/FINISH

OMIT FOR SOLDER CUP CONTACTS

1 - ALL WHITE
2 - ALL YELLOW
3 - FIRST 10 COLORS BLK THRU WHT REPEATS
4 - FULL COLOR CODED PER MIL-STD-681, SYSTEM 1
0 - SOLID WIRE TERMINATION

FLANGE HARDWARE

SIZES 9-51 USES #2-56, 100 USES #4-40

COMMERCIAL PERMANENT OPTIONS:

A - .125 DIA. MTG. HOLES, FOR SIZE 9-51
.166 DIA MTG HOLES FOR SIZE 100

B - (STANDARD HOLE SIZES PER M83513)

.092 DIA. MTG. HOLES FOR SIZE 9-51
.150/.145 DIA. MTG. HOLE FOR SIZE 100

J - CAPTIVE, HIGH PROFILE .050 HEX JACKSCREW

K - CAPTIVE, HIGH PROFILE SLOTTED JACKSCREW

L - CAPTIVE, LOW PROFILE .050 HEX JACKSCREW

F - STANDARD FLOAT MOUNT

R - REVERSE FLOAT MOUNT

T - THREADED INSERT

Z - POLARIZED HARDWARE <3>

MILITARY OPTIONS (FROM M83513/05-XX)

2 - LOW PROFILE .050 HEX JACKSCREW

3 - HIGH PROFILE .050 HEX JACKSCREW

5 - LOW PROFILE SLOTTED JACKSCREW

6 - HIGH PROFILE SLOTTED JACKSCREW

7 - JACKPOST KIT

SHELL FINISH (& MATERIAL)

A - ANODIZE (ALUMINUM)

C - CADMIUM (ALUMINUM)

G - GOLD (ALUMINUM)

N - ELECTROLESS NICKEL (ALUMINUM)

S - PASSIVATION (STAINLESS STEEL)

T - TIN (ALUMINUM)

WIRE LENGTH

OMIT FOR SOLDER CUP CONTACTS

1 - 0.25	} (SOLID WIRE ONLY, + 0.20/- 0.00)
2 - 0.50	
3 - 1.00	
4 - 6.00	
5 - 12.00	} (STRANDED WIRE ONLY, + 1.00/- 0.00)
6 - 18.00	
7 - 24.00	
8 - 36.00	
9 - 72.00	

<1> - CONNECTOR TERMINATION TYPE NOT AVAILABLE AT TIME OF PRINTING. CONTACT FACTORY FOR CURRENT AVAILABILITY.

<2> - ADDITIONAL SIZES MAY BE AVAILABLE. CONTACT FACTORY FOR CURRENT AVAILABILITY.

<3> - POLARIZED HARDWARE OPTIONS AVAILABLE. CONTACT FACTORY FOR DETAILS AND APPLICABLE DASH NUMBER.

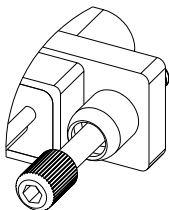

J - HIGH PROFILE HEX

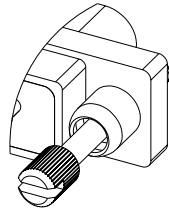

K - HIGH PROFILE SLOTTED

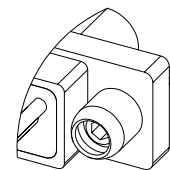

L - LOW PROFILE HEX

CAPTIVE PERMANENT JACKSCREW OPTIONS

(FOR MILITARY HARDWARE OPTIONS, SEE HMM05 PAGE IN HMM OR HARDWARE AND ACCESSORIES SECTIONS)

SEE THE FIRST PAGE OF THIS SECTION FOR PERFORMANCE, MATERIAL, AND PLATING INFORMATION

MICROMINIATURE – COTS MICRO-D CONNECTORS

HDM01 THRU 04 – PRE-WIRED AND SOLDER CUP TERMINATIONS

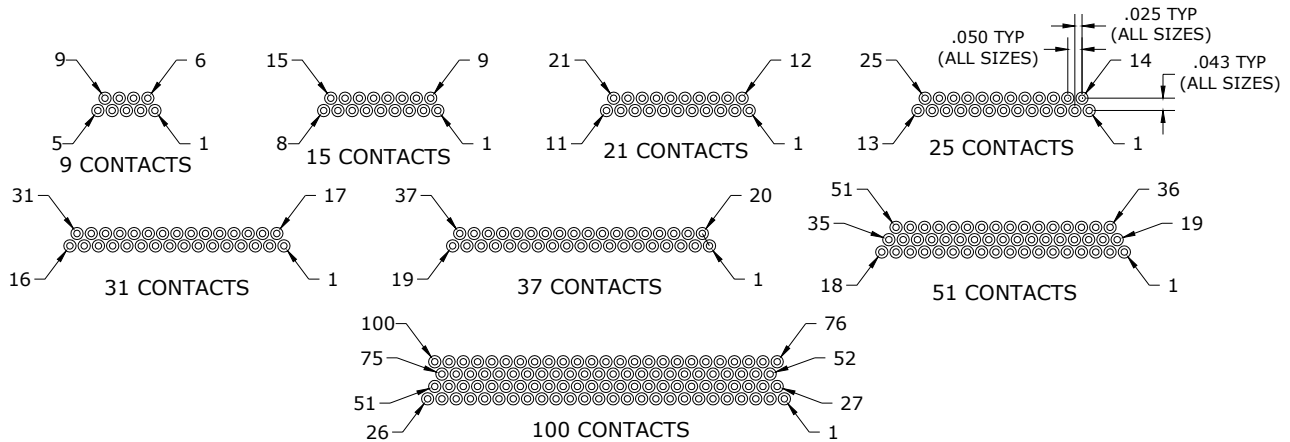

CONTACT ARRANGEMENTS

(FACE VIEW OF PIN INSERT SHOWN, REVERSE ORDER FOR SOCKET SIDE)

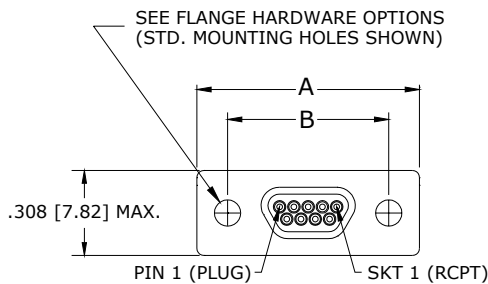

SIZE	A MAX.	B NOM.	C MAX.
9	.785 [19.94]	.565 [14.35]	.400 [10.16]
15	.935 [23.75]	.715 [18.16]	.550 [13.97]
21	1.085 [27.56]	.865 [21.97]	.700 [17.78]
25	1.185 [30.10]	.965 [24.51]	.800 [20.32]
31	1.335 [33.91]	1.115 [28.32]	.950 [24.13]
37	1.485 [37.72]	1.265 [32.13]	1.100 [27.94]
51	1.435 [36.45]	1.215 [30.86]	1.050 [26.67]
100	2.170 [55.12]	1.800 [45.72]	1.442 [36.63]

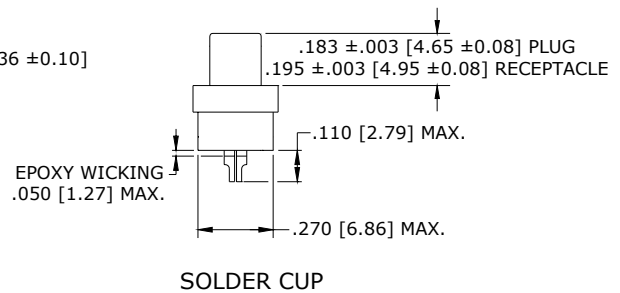
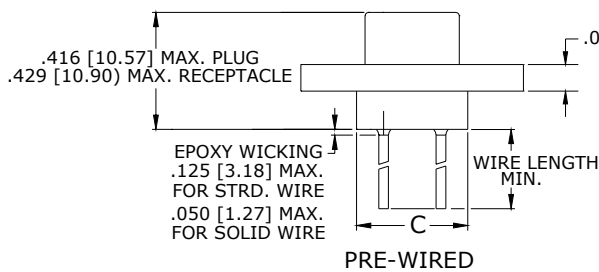

SIZES 9 - 37

(SIZE 9 PLUG (PIN CONTACTS) SHOWN)

DIMENSIONS ARE IN INCHES [MILLIMETERS], TOLERANCE UNLESS OTHERWISE NOTED IS ±.005 [0.13]

MICROMINIATURE – COTS MICRO-D CONNECTORS

HDM01 THRU 04 – PRE-WIRED AND SOLDER CUP TERMINATIONS

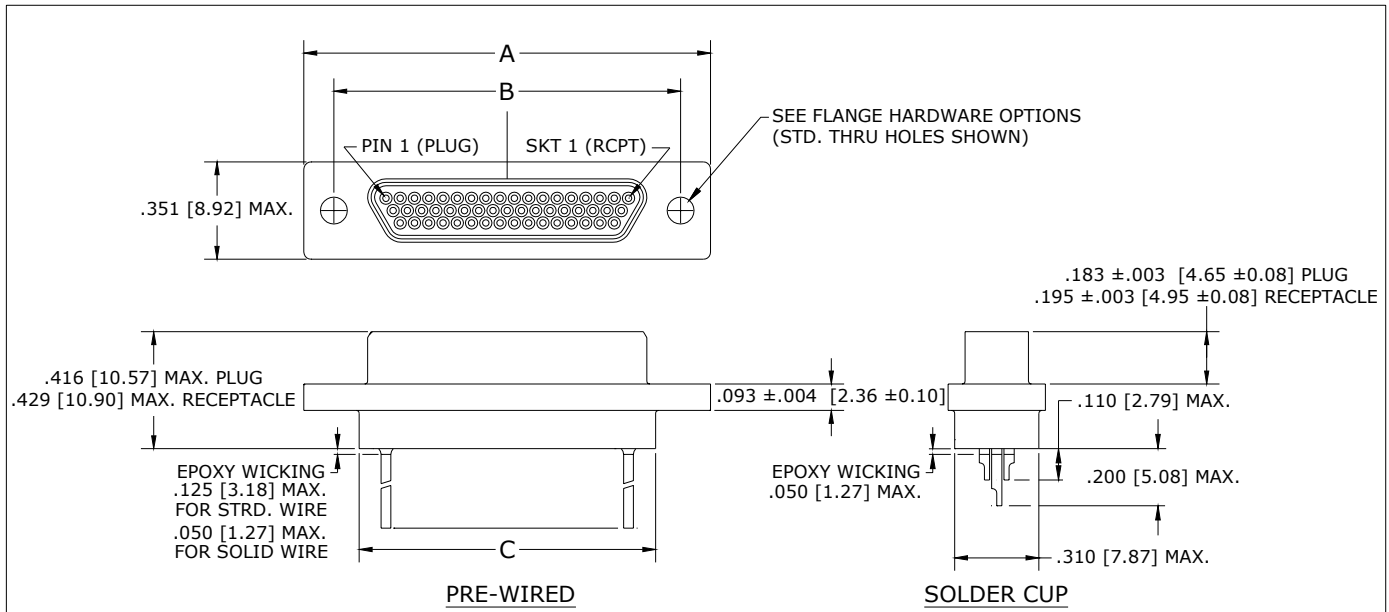

SIZE 51
(SIZE 51 PLUG (PIN CONTACTS) SHOWN)

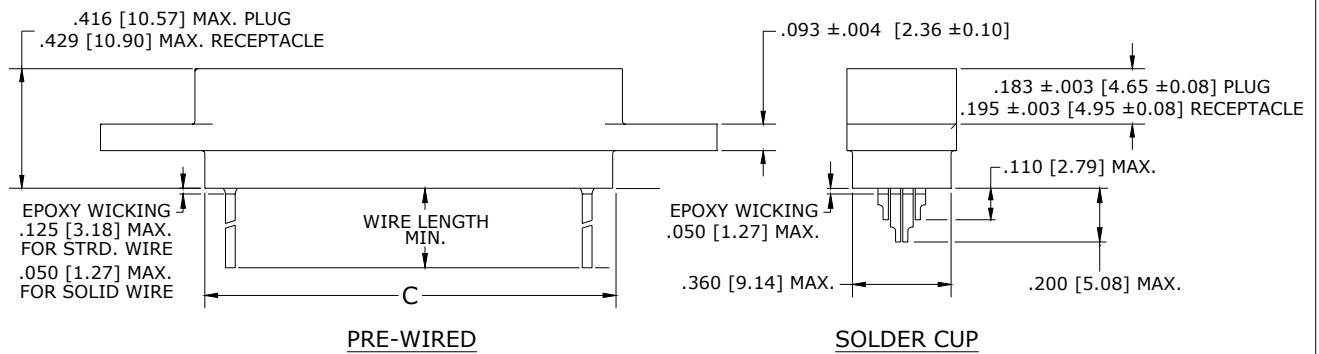
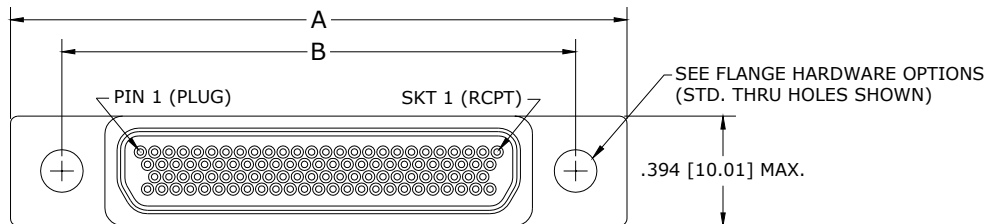

SIZE 100
(SIZE 100 RECEPTACLE (SOCKET CONTACTS) SHOWN)

DIMENSIONS ARE IN INCHES [MILLIMETERS], TOLERANCE UNLESS OTHERWISE NOTED IS ±.005 [0.13]