

T-1 3/4 Clear Lens										
Part Number	Source Color	Wave-length λ_p (nm)	Lens Color	Typical Viewing Angle	Forward Voltage V_F (V)		Luminous Intensity I_V (mcd)		Notes	
					typ	max	min	typ		
MV5052		660	Red Clear	72°	1.6	2.0	0.7	1.0	4	
HLMP-3315		635	Red Clear	35°	2.2	3.0	12	18	3	
HLMP-3316		635	Red Clear	35°	2.2	3.0	20	35	3	
MV3750		635	Orange Clear	24°	2.2	3.0	80	150	4	
MV5152		635	Amber Clear	28°	2.0	3.0	17	100	4	
MV5752		635	Red Clear	28°	2.0	3.0	17	100	4	
MV6152		635	Amber Clear	28°	2.0	3.0	17	100	4	
MV6752		635	Red Clear	28°	2.0	3.0	17	100	4	
MV3450		565	Green Clear	24°	2.2	3.0	80	150	4	
MV5452		565	Green Clear	35°	2.2	3.0	12	25	4	
MV64520		565	Green Clear	35°	2.2	3.0	12	25	4	
MV64521		565	Green Clear	35°	2.2	3.0	30	100	4	
MV3350		585	Yellow Clear	24°	2.2	3.0	80	150	4	
MV5352	Yellow	585	Yellow Clear	28°	2.1	3.0	10	90	4	
MV6352		585	Yellow Clear	28°	2.1	3.0	10	90	4	
HLMP-D640		560	Water Clear	24°	2.2	3.0	6.7	60	4	

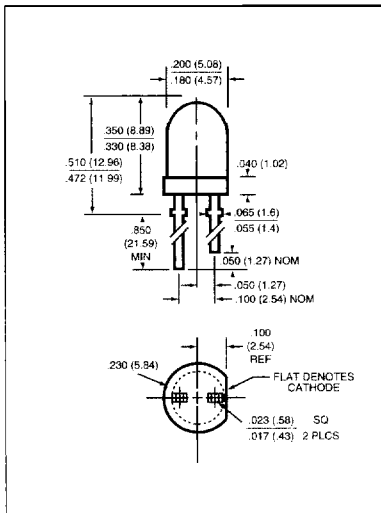

T-1 3/4 Clear Lens with Standoff										
Part Number	Source Color	Wave-length λ_p (nm)	Lens Color	Typical Viewing Angle	Forward Voltage V_F (V)		Luminous Intensity I_V (mcd)		Notes	
					typ	max	min	typ		
HLMP-3750A		635	Orange Clear	24°	2.2	3.0	80	150	4	
HLMP-3950A		565	Green Clear	24°	2.2	3.0	80	150	4	
HLMP-3850A	Yellow	585	Yellow Clear	24°	2.2	3.0	80	150	4	
HLMP-D105A		660	Red Clear	24°	1.6	2.2	100	240	4	

T-1 3/4 Narrow Angle Diffused Lens										
Part Number	Source Color	Wave-length λ_p (nm)	Lens Color	Typical Viewing Angle	Forward Voltage V_F (V)		Luminous Intensity I_V (mcd)		Notes	
					typ	max	min	typ		
MV5054A1	Yellow	660	Red Diffused	24°	1.8	2.2	1.0	1.5	3	
MV5054A2		660	Red Diffused	24°	1.8	2.2	2.0	2.5	3	
MV5054A3		660	Red Diffused	24°	1.8	2.2	3.0	3.5	3	
MV5154A		635	Amber Diffused	24°	2.0	3.0	10.0	25.0	4	
MV5754A		635	Red Diffused	24°	2.0	3.0	10.0	25.0	4	
MV6154A		635	Amber Diffused	24°	2.0	3.0	10.0	25.0	4	
MV6754A		635	Red Diffused	24°	2.0	3.0	10.0	25.0	4	
MV5454A		565	Green Diffused	24°	2.2	3.0	10.0	30.0	4	
MV6454A		565	Green Diffused	24°	2.2	3.0	10.0	30.0	4	
MV5354A		585	Yellow Diffused	24°	2.1	3.0	10.0	25.0	4	
MV6354A	585	Yellow Diffused	24°	2.1	3.0	10.0	25.0	4		

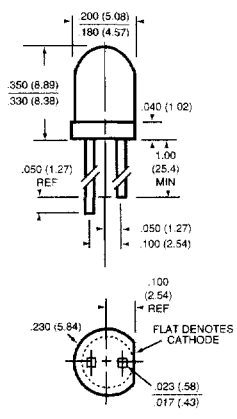

Pkg Shown:
MV6X54 Anode long
Not Shown:
MV5X54 Cathode long

T-1 3/4 Tapered Lens										
Part Number	Source Color	Wave-length λ_p (nm)	Lens Color	Typical Viewing Angle	Forward Voltage V_F (V)		Luminous Intensity I_V (mcd)		Notes	
					typ	max	min	typ		
MV5021A	Yellow	660	White Diffused	80°	1.65	2.0	0.5	1.6	4	
MV5022A		660	Red Clear	80°	1.65	2.0	0.6	1.6	4	
MV5023A		660	Red Diffused	80°	1.65	2.0	0.4	1.6	4	
MV5024A		660	Red Diffused	40°	1.65	2.0	0.9	3.0	4	
MV5025A		660	Red Diffused	180°	1.65	2.0	0.1	0.4	4	
MV5026A		660	Deep Red Diffused	80°	1.65	2.0	0.1	0.6	4	

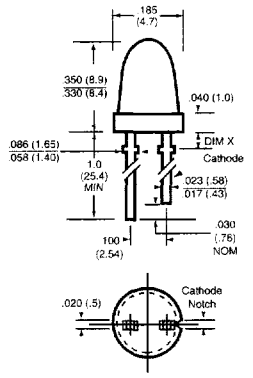

Part Number DIM X
MAX MIN
MV5021A/22A/23A 115 (2.9) .085 (2.2)
MV5024A/25A/26A 145 (3.7) 115 (2.9)

Notes

- 3. V_F & I_V @ $I_F = 10$ mA
 - 4. V_F & I_V @ $I_F = 20$ mA
- HER = High Efficiency Red