

CRYSTAL CONTROLLED OSCILLATORS

3.3V 14 PIN LVPECL VCXO OSCILLATOR WITH ENABLE / DISABLE FUNCTION

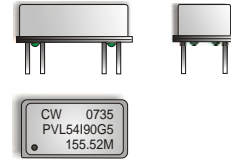

PVL54190G5

ABSOLUTE MAXIMUM RATINGS

TABLE 1.0

PARAMETER	UNITS	MINIMUM	NOMINAL	MAXIMUM	UNITS	NOTE
Storage Temperature		-55	-	125	°C	
Supply Voltage	(Vcc)	-0.5	-	7.0	Vdc	
Control Voltage	(Vc)	-0.5	-	7.0	Vdc	

OPERATING SPECIFICATIONS

TABLE 2.0

PARAMETER		MINIMUM	NOMINAL	MAXIMUM	UNITS	NOTE
Center Frequency	(Fo)		86.097902 155.5200 166.6285		MHz	
Frequency vs. Temperature		-10	-	10	ppm	1
Frequency vs. Calibration @ 25°C		-5	-	5	ppm	1
Frequency vs. Aging (10 years)		-5	-	5	ppm	
Total Frequency Tolerance		-20	-	20	ppm	2
Operating Temperature Range		0	-	70	°C	
Supply Voltage	(Vcc)	3.135	3.3	3.465	Vdc	
Supply Current	(Icc)	-	-	80	mA	
Jitter (BW=10Hz to 20MHz)		-	-	5	ps rms	
Jitter (BW=12kHz to 20MHz)		-	-	1	ps rms	
SSB Phase Noise at 100Hz offset		-	-80	-	dBc/Hz	
SSB Phase Noise at 1KHz offset		-	-100	-	dBc/Hz	
SSB Phase Noise at 10KHz offset		-	-130	-	dBc/Hz	
SSB Phase Noise at 100KHz offset		-	-135	-	dBc/Hz	

INPUT CHARACTERISTICS

TABLE 3.0

PARAMETER		MINIMUM	NOMINAL	MAXIMUM	UNITS	NOTE
Control Voltage Range	(Vc)	0.3	1.65	3.0	Vdc	
Frequency Pullability @ 25 °C		+/-45	-	+/-90	ppm	3
Absolute Pull Range		+/-30	-	-	ppm	4
Monotonic Linearity		-10	-	10	%	
Input Impedance		50K	-	-	Ohm	
Modulation Bandwidth (3dB)		10	-	-	kHz	
Disable Input Voltage (High)	(Vih)	-	2.26	-	Vdc	5
Enable Input Voltage (Low)	(Vil)	-	1.70	-	Vdc	5

LVPECL OUTPUT CHARACTERISTICS

TABLE 4.0

PARAMETER		MINIMUM	NOMINAL	MAXIMUM	UNITS	NOTE
LOAD		-	-	50	Ohms	6
Voltage (High)	(Voh)	2.26	-	-	Vdc	
(Low)	(Vol)	-	-	1.70	Vdc	
Duty Cycle at 50% Level		45	50	55	%	
Rise / Fall Time 20% to 80%		-	-	1.0	nS	

PACKAGE CHARACTERISTICS

TABLE 5.0

Package	Hermetically sealed metal 14 pin package.
---------	---

Notes

- Control Voltage @ 1.65V
- Includes initial tolerance, deviation over temperature, supply and load variations, shock, vibration and aging.
- Referenced to Fo at 1.65V, Positive Slope.
- Absolute pull range (APR) is the minimum guaranteed pull range of the VCXO under all conditions over lifetime operation. The APR is referenced to Fo.
- When oscillator is disabled the true output is in a low state (Vol) and the complementary output is in the high state (Voh)
- Output terminated into 50 ohms into Vcc – 2.0Vdc or Thevenin equivalent.

DESCRIPTION

The Connor-Winfield PVL54190G5 is a 3.3V Voltage controlled crystal oscillator (VCXO) with Differential PECL outputs. Based on a fundamental design the PVL54190G5 is designed for phased lock loop applications requiring low jitter and tight frequency stability.

FEATURES

- 3.3V OPERATION
- LOW JITTER <1ps RMS
- TOTAL FREQUENCY TOLERANCE: ±20PPM
- TEMPERATURE RANGE: 0 to 70°C
- DIFFERENTIAL LVPECL OUTPUTS
- ENABLE/DISABLE FUNCTION
- HERMETICALLY SEALED DIP PACKAGE
- RoHS 5/6 COMPLIANT

ORDERING INFORMATION

PVL54190G5 - 155.52 MHz

VCXO SERIES CENTER FREQUENCY

Specifications subject to change without notice.

CRYSTAL CONTROLLED OSCILLATORS

Package Outline

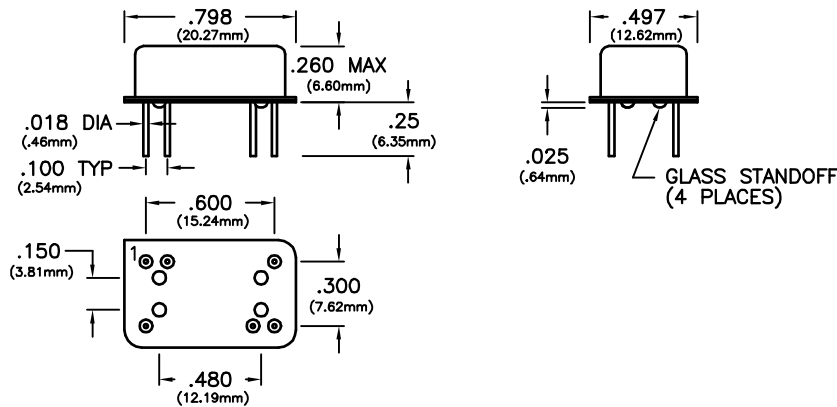

Solder Profile

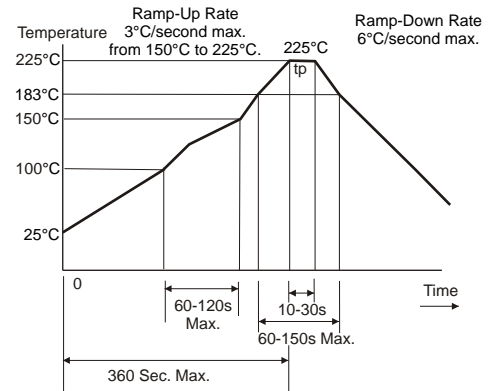

Output Waveform

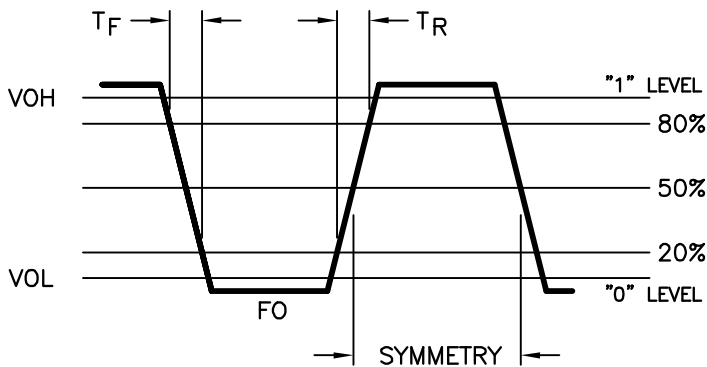

Pin Connections

PIN	CONNECTION
1	CONTROL VOLTAGE
2	ENABLE/DISABLE
7	GROUND (CASE)
8	OUTPUT Q
9	COMP OUTPUT Q̄
14	(+) SUPPLY

Test Circuit

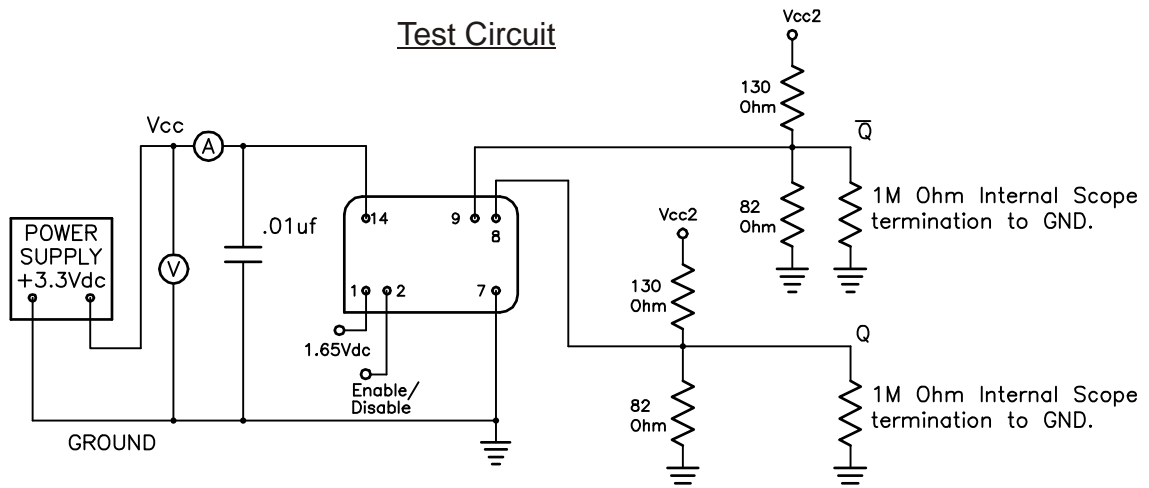

Specifications subject to change without notice.