



## Features

- Lead free versions available
- RoHS compliant (lead free version)\*
- Multiple resistors tied to a common node
- Stable thin-film-on-silicon technology
- Ultra-miniature packages to JEDEC standards

## Applications

- Bus termination
- Pull-up/pull-down
- Ideal for space-constrained applications

# Thin Film on Silicon 2QSP / 2NBS-XX2 Bussed Resistors

### General Information

Bussed Resistor networks are typically used in DC pull-up and pull-down applications where system data or control lines must be tied to a fixed potential. Fabricated with a Tantalum Nitride and Nickel Chromium on Silicon process, these resistors feature excellent stability, TCR and tracking performance. Bussed Resistor Networks are available in a range of miniature package types conforming to JEDEC standards.

### Package Schematic

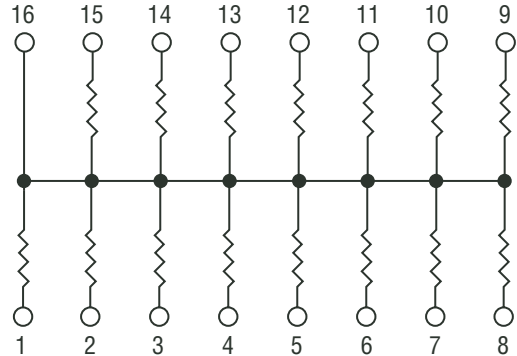

### Electrical & Environmental Characteristics

Electrical Characteristics	Symbol	Minimum	Nominal	Maximum	Unit
Resistance Range	R	100		100 K	$\Omega$
Tolerance:					
Absolute		$\pm 0.5\%$		$\pm 5\%$	$\Omega$
Ratio		$\pm 0.1\%$		$\pm 2\%$	$\Omega$
TCR:					
Absolute			100	150	ppm/ $^{\circ}$ C
Tracking				25	ppm/ $^{\circ}$ C
Operating Voltage				50	V
<b>Environmental Characteristics</b>					
ESD		2 K			V
Operating Temperature	$T_J$	-55		+125	$^{\circ}$ C
Storage Temperature	$T_{stg}$	-65		+150	$^{\circ}$ C
Power Rating per Resistor @ 70 $^{\circ}$ C				0.1	Watt
Power Rating per Package @ 70 $^{\circ}$ C:					
QSOP: 16 Pin				0.75	Watt
20, 24 Pin				1.00	Watt
28 Pin				1.12	Watt
NBSOIC: 8 Pin				0.60	Watt
14, 16 Pin				1.00	Watt

\*RoHS Directive 2002/95/EC Jan 27 2003 including Annex

Specifications are subject to change without notice.

Customers should verify actual device performance in their specific applications.

# Thin Film on Silicon 2QSP / 2NBS -XX2 Bussed Resistors



## Mechanical Characteristics

### QSOP Package Dimensions

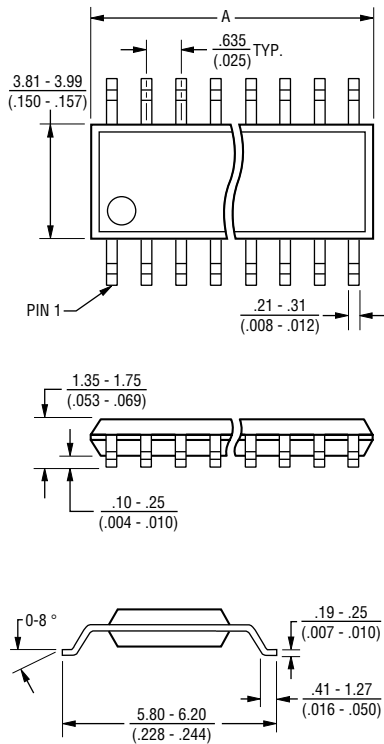

Model	A
2QSP16	4.80 - 4.98 (.189 - .196)
2QSP20	8.56 - 8.74 (.337 - .344)
2QSP24	8.56 - 8.74 (.337 - .344)
2QSP28	9.80 - 9.98 (.386 - .393)

Governing dimensions are in mm. Dimensions in parentheses are in inches and are approximate.

JEDEC Reference Number MO-137.

### Narrow-Body SOIC Package Dimensions

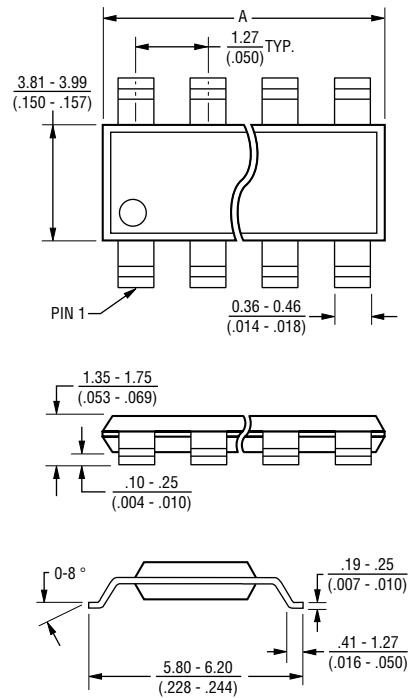

Model	A
2NBS08	4.80 - 4.98 (.189 - .196)
2NBS14	8.56 - 8.74 (.337 - .344)
2NBS16	9.80 - 9.98 (.386 - .393)

Governing dimensions are in mm. Dimensions in parentheses are in inches and are approximate.

JEDEC Reference Number MS-012.

# Thin Film on Silicon 2QSP / 2NBS -XX2 Bussed Resistors



QSOP Package Power Temperature Derating Curve

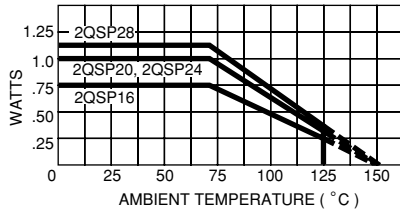

Narrow-Body SOIC Package Power Temperature Derating Curve

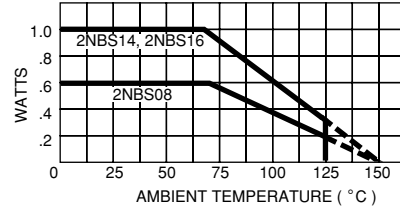

Schematic

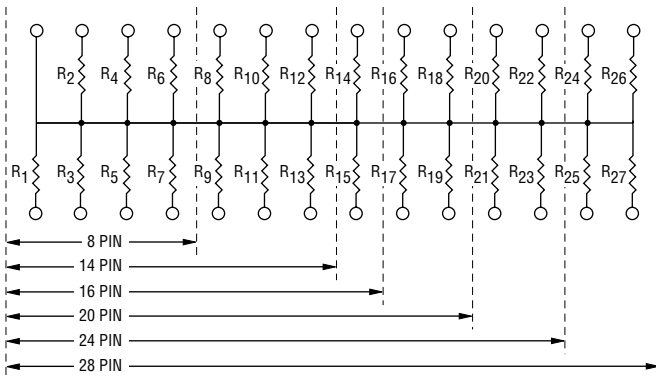

Standard Resistance Values

Resistance (ohms)	Resistance Code
100	101
120	121
220	221
270	271
330	331
390	391
470	471
510	511
680	681
1 K	102
1.5 K	152
2 K	202
2.2 K	222
2.7 K	272
3.3 K	332
4.7 K	472
5.1 K	512
10 K	103
20 K	203
27 K	273
47 K	473
51 K	513
75 K	753
82 K	823
100 K	104

Typical Part Marking

Represents total content. Layout may vary.

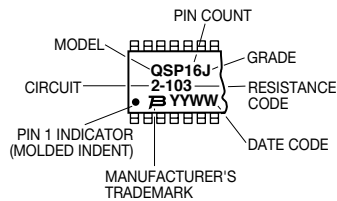

# Thin Film on Silicon 2QSP / 2NBS -XX2 Bussed Resistors



## Dispensing

For large quantities, the product will be dispensed in Tape and Reel (see diagram below).

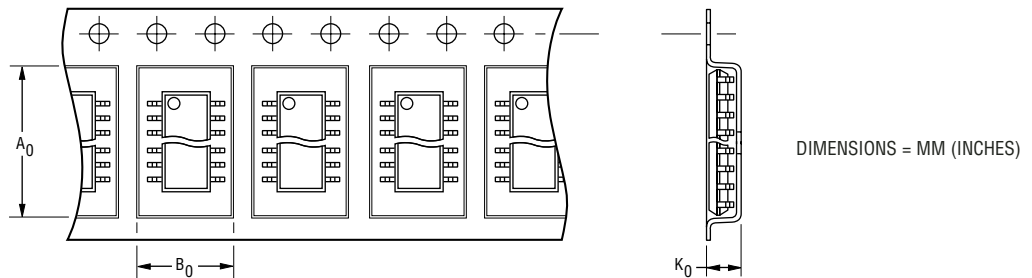

Package	A <sub>0</sub>	B <sub>0</sub>	K <sub>0</sub>	Width	Pitch	No. of Pieces per 13" reel	No. of Pieces per tube
<b>QSOP</b>							
16 Pin	6.4 (0.252)	5.2 (0.205)	2.1 (0.083)	12 (0.472)	8 (0.315)	3,500	98
20, 24 Pin	6.5 (0.256)	9.0 (0.354)	2.1 (0.083)	16 (0.630)	8 (0.315)	3,500	56
28 Pin	6.5 (0.256)	10.3 (0.406)	2.1 (0.083)	16 (0.630)	8 (0.315)	3,500	49
<b>NBSOIC</b>							
8 Pin	6.4 (0.252)	9.0 (0.354)	2.1 (0.083)	12 (0.472)	8 (0.315)	3,500	98
14 Pin	6.5 (0.256)	9.0 (0.354)	2.1 (0.083)	16 (0.630)	8 (0.315)	3,500	56
16 Pin	6.5 (0.256)	9.0 (0.354)	2.1 (0.083)	16 (0.630)	8 (0.315)	3,500	49

## How To Order

**2 QSP 20 - T J 2 - 472**

Product Class \_\_\_\_\_  
Thin-Film-on-Silicon

Standard Package Style \_\_\_\_\_  
QSP = QSOP  
NBS = Narrow-Body SOIC

Pin Count \_\_\_\_\_  
QSP = 16, 20, 24, 28  
NBS = 8, 14, 16

Dispensing \_\_\_\_\_  
R = Reel  
T = Tube

Standard Grade \_\_\_\_\_  
Tolerance  
J = ±5 %  
G = ±2 %  
F = ±1 %

Circuit \_\_\_\_\_  
2 = Bussed

Resistance Value Code \_\_\_\_\_  
1st two digits are significant,  
3rd digit = number of zeros to follow to give resistance value in ohms.

Terminations \_\_\_\_\_  
LF = 100 % Sn (lead free)  
Blank = Sn/Pb



*Reliable Electronic Solutions*

### Asia-Pacific:

Tel: +886-2 2562-4117 • Fax: +886-2 2562-4116

### Europe:

Tel: +41-41 768 5555 • Fax: +41-41 768 5510

### The Americas:

Tel: +1-951 781-5500 • Fax: +1-951 781-5700

[www.bourns.com](http://www.bourns.com)