



## Notebook LCD Panel EMI Reduction IC

### Features

- FCC approved method of EMI attenuation.
- Provides up to 15dB EMI reduction.
- Generates a low EMI Spread Spectrum clock and a non-spread reference clock of the input frequency.
- Optimized for Frequency range from 20 to 40MHz.
- Internal loop filter minimizes external components and board space.
- Low Inherent Cycle-to-Cycle jitter.
- Two spread % selections: -1.25% to -1.75%.
- 3.3V Operating Voltage.
- Low power CMOS design.
- Supports notebook VGA and other LCD timing controller applications.
- Power Down function for mobile application.
- Available in Commercial temperature range.
- Available in 8-pin SOIC and TSSOP Packages.
- RoHS Compliant

### Product Description

The ASM3P18S19B is a Versatile Spread Spectrum Frequency Modulator designed specifically for input clock frequencies from 20 to 40MHz. (Refer to *Input Frequency and Modulation Rate Table*). The ASM3P18S19B reduces electromagnetic interference (EMI) at the clock source, allowing system wide reduction of EMI of down stream

clock and data dependent signals. The ASM3P18S19B allows significant system cost savings by reducing the number of circuit board layers, ferrite beads, shielding, and other passive components that are traditionally required to pass EMI regulations.

The ASM3P18S19B modulates the output of a single PLL in order to “spread” the bandwidth of a synthesized clock, and more importantly, decreases the peak amplitudes of its harmonics. This results in significantly lower system EMI compared to the typical narrow band signal produced by oscillators and most frequency generators. Lowering EMI by increasing a signal’s bandwidth is called ‘Spread Spectrum Clock Generation’.

The ASM3P18S19B uses the most efficient and optimized modulation profile approved by the FCC and is implemented in a proprietary all digital method.

### Applications

The ASM3P18S19B is targeted towards EMI management for memory and LVDS interfaces in mobile graphic chipsets and high-speed digital applications such as PC peripheral devices, consumer electronics, and embedded controller systems.

### Block Diagram

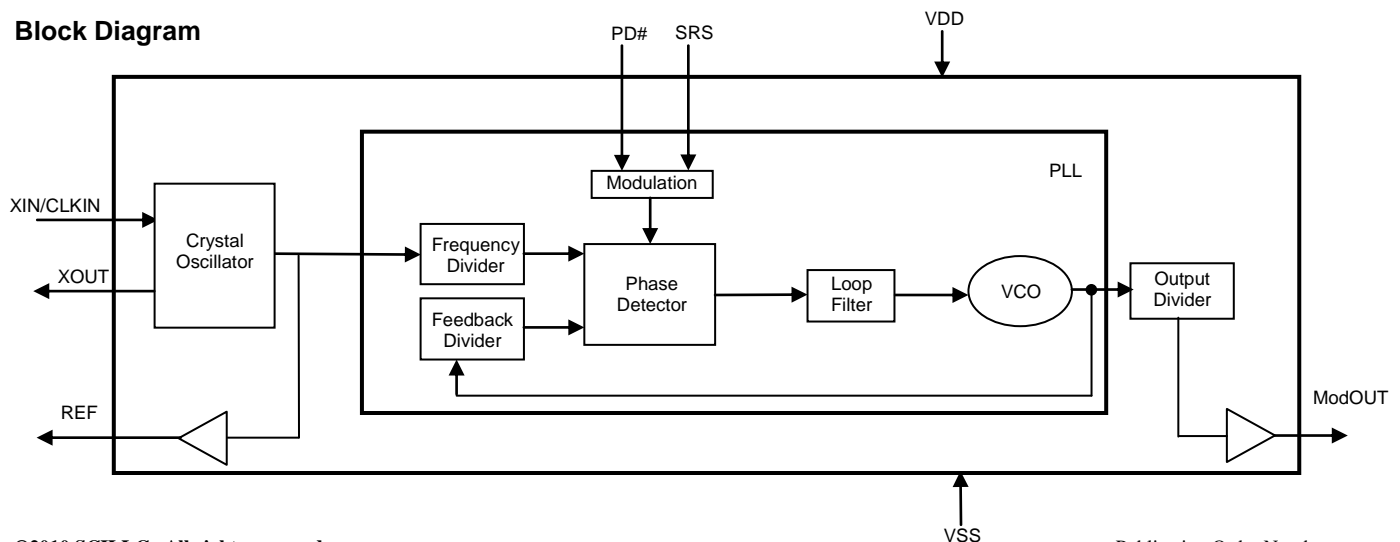

## Pin Configuration

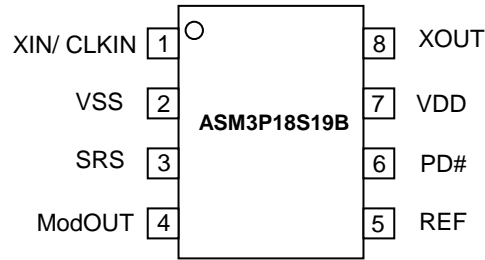

## Pin Description

Pin#	Pin Name	Type	Description
1	XIN / CLKIN	I	Crystal Connection or external frequency input. This pin has dual functions. It can be connected to either an external crystal or an external reference clock.
2	VSS	P	Ground Connection. Connect to system ground.
3	SRS	I	Spread range select. Digital logic input used to select frequency deviation (Refer to <i>Spread Deviation Selection Table</i> ). This pin has an internal pull-up resistor.
4	ModOUT	O	Spread spectrum clock output. (Refer to <i>Input Frequency and Modulation Rate Table</i> and <i>Spread Deviation Selection Table</i> )
5	REF	O	Non-modulated Reference clock output of the input frequency.
6	PD#	I	Power down control pin. Pull LOW to enable Power-Down mode. This pin has an internal pull-up resistor.
7	VDD	P	Power Supply for the entire chip.
8	XOUT	O	Crystal Connection. Input connection for an external crystal. If using an external reference, this pin must be left unconnected.

## Input Frequency and Modulation Rate

Part Number	Input Frequency Range	Output Frequency range	Modulation rate
ASM3P18S19B	20MHz to 40MHz	20MHz to 40MHz	Input Frequency / 512

## Spread Deviation Selection

Part Number	SRS	Spread Deviation
ASM3P18S19B	0	-1.25% (DOWN)
	1	-1.75% (DOWN)

## Absolute Maximum Ratings

Symbol	Parameter	Rating	Unit
VDD, V <sub>IN</sub>	Voltage on any pin with respect to Ground	-0.5 to +4.6	V
T <sub>STG</sub>	Storage temperature	-65 to +125	°C
T <sub>A</sub>	Operating temperature	0 to +70	°C
T <sub>s</sub>	Max. Soldering Temperature (10 sec)	260	°C
T <sub>J</sub>	Junction Temperature	150	°C
T <sub>DV</sub>	Static Discharge Voltage (As per JEDEC STD22- A114-B)	2	KV

Note: These are stress ratings only and are not implied for functional use. Exposure to absolute maximum ratings for prolonged periods of time may affect device reliability.

## DC Electrical Characteristics

(Test condition: All parameters are measured at room temperature (+25°C) unless otherwise stated.)

Symbol	Parameter	Min	Typ	Max	Unit
V <sub>IL</sub>	Input Low voltage	VSS - 0.3	-	0.8	V
V <sub>IH</sub>	Input High voltage	2.0	-	VDD + 0.3	V
I <sub>IL</sub>	Input Low current (inputs PD#, SRS)	-60.0	-	-20.0	μA
I <sub>IH</sub>	Input High current	-	-	1.0	μA
I <sub>XOL</sub>	X <sub>OUT</sub> Output low current @ 0.4V, VDD = 3.3V	-	3	-	mA
I <sub>XOH</sub>	X <sub>OUT</sub> Output high current @ 2.5V, VDD = 3.3V	-	3	-	mA
V <sub>OL</sub>	Output Low voltage VDD = 3.3V, I <sub>OL</sub> = 20mA	-	-	0.4	V
V <sub>OH</sub>	Output High voltage VDD = 3.3V, I <sub>OH</sub> = 20mA	2.5	-	-	V
I <sub>CC</sub>	Dynamic supply current normal mode 3.3V and 25pF probe loading	7.1 f <sub>IN</sub> - min	-	26.9 f <sub>IN</sub> - max	mA
I <sub>DD</sub>	Static supply current standby mode	-	4.5	-	mA
VDD	Operating Voltage	-	3.3	-	V
t <sub>ON</sub>	Power up time (first locked clock cycle after power up)	-	0.18	-	mS
Z <sub>OUT</sub>	Clock Output impedance	-	50	-	Ω

## AC Electrical Characteristics

Symbol	Parameter	Min	Typ	Max	Unit
f <sub>IN</sub>	Input Frequency	20	-	40	MHz
f <sub>OUT</sub>	Output Frequency	20	-	40	MHz
t <sub>LH</sub> *	Output Rise time Measured from 0.8V to 2.0V	-	0.66	-	nS
t <sub>HL</sub> *	Output Fall time Measured from 0.8V to 2.0V	-	0.65	-	nS
t <sub>JC</sub>	Jitter (Cycle to cycle)	-200	-	200	pS
t <sub>D</sub>	Output Duty cycle	45	50	55	%

\*t<sub>LH</sub> and t<sub>HL</sub> are measured into a capacitive load of 15pF

## Package Information

### 8-lead (150-mil) SOIC Package

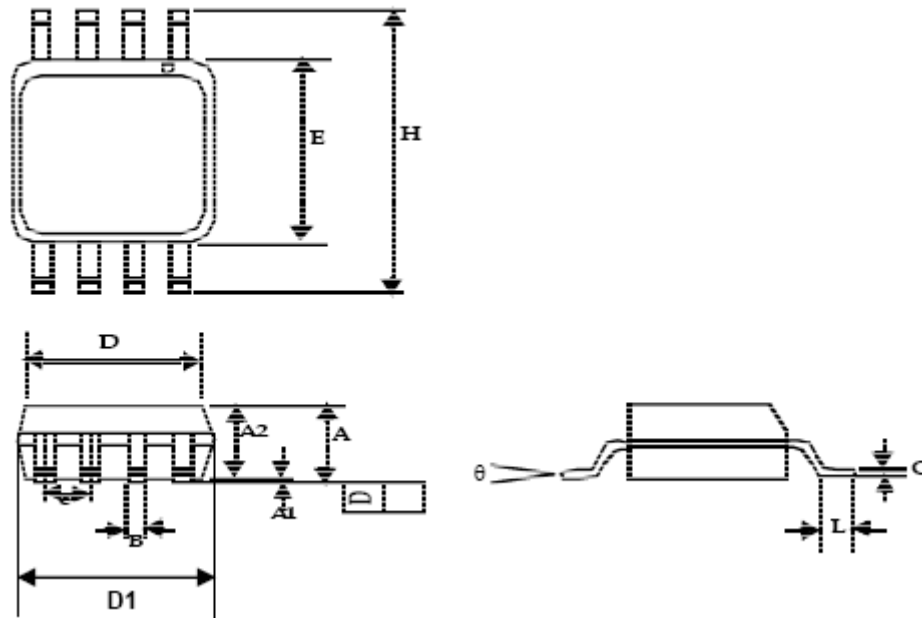

Symbol	Dimensions			
	Inches		Millimeters	
	Min	Max	Min	Max
A1	0.004	0.010	0.10	0.25
A	0.053	0.069	1.35	1.75
A2	0.049	0.059	1.25	1.50
B	0.012	0.020	0.31	0.51
C	0.007	0.010	0.18	0.25
D	0.193 BSC		4.90 BSC	
E	0.154 BSC		3.91 BSC	
e	0.050 BSC		1.27 BSC	
H	0.236 BSC		6.00 BSC	
L	0.016	0.050	0.41	1.27
θ	0°	8°	0°	8°

Package length (Excluding end flash) D - 188 ~ 193 mils.

Package length (Including end flash) D1 - 198 ~ 207 mils.

## 8-lead TSSOP (4.40-MM Body)

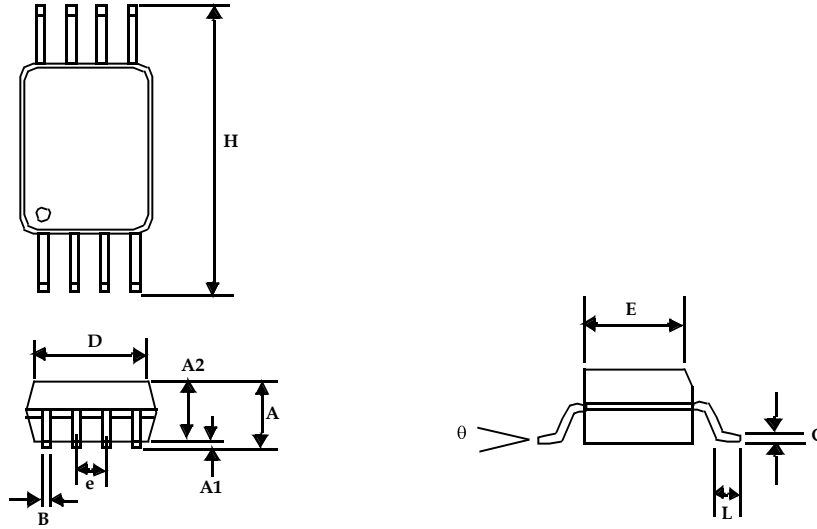

Symbol	Dimensions			
	Inches		Millimeters	
	Min	Max	Min	Max
A		0.043		1.10
A1	0.002	0.006	0.05	0.15
A2	0.033	0.037	0.85	0.95
B	0.008	0.012	0.19	0.30
C	0.004	0.008	0.09	0.20
D	0.114	0.122	2.90	3.10
E	0.169	0.177	4.30	4.50
e	0.026 BSC		0.65 BSC	
H	0.252 BSC		6.40 BSC	
L	0.020	0.028	0.50	0.70
$\theta$	0°	8°	0°	8°

Note: Controlling dimensions are millimeters  
TSSOP – 0.0325 grams unit weight

# ASM3P18S19B

## Ordering Information

Part Number	Marking	Package Type	Temperature
ASM3P18S19BF-08TT	3P18S19BF	8-Pin TSSOP, TUBE, Pb Free	Commercial
ASM3P18S19BF-08TR	3P18S19BF	8-Pin TSSOP, TAPE & REEL, Pb Free	Commercial
P3P18S19BF-08ST	3P18S19BF	8-Pin SOIC, TUBE, Pb Free	Commercial
P3P18S19BF-08SR	3P18S19BF	8-Pin SOIC, TAPE & Pb Free	Commercial
ASM3P18S19BG-08TT	3P18S19BG	8-Pin TSSOP, TUBE, Green	Commercial
ASM3P18S19BG-08TR	3P18S19BG	8-Pin TSSOP, TAPE & REEL, Green	Commercial
ASM3P18S19BG-08ST	3P18S19BG	8-Pin SOIC, TUBE, Green	Commercial
ASM3P18S19BG-08SR	3P18S19BG	8-Pin SOIC, TAPE & REEL, Green	Commercial

Products are available for industrial temperature range operation. Please contact factory for more information.

## Device Ordering Information

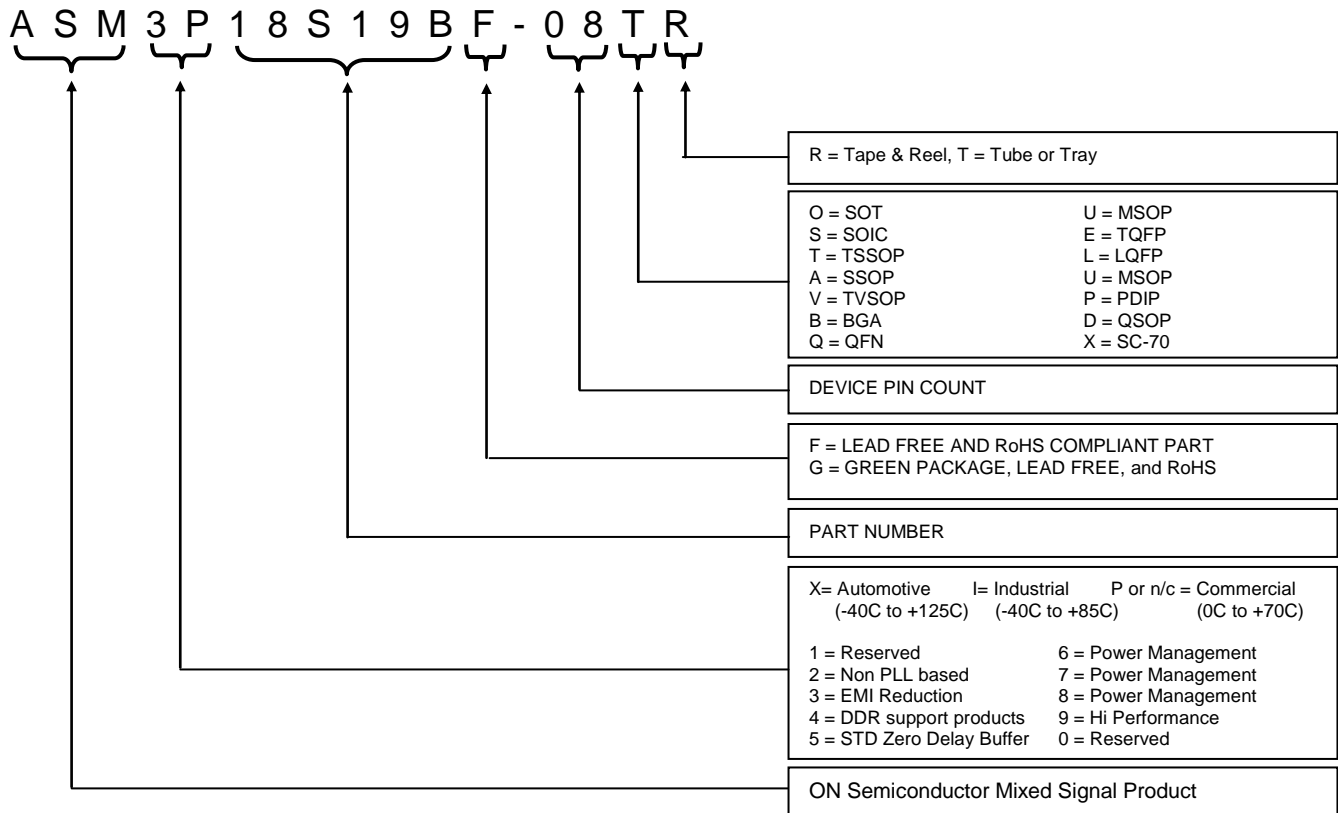

Licensed under US patent #5,488,627, #6,646,463 and #5,631,920.

Note: This product utilizes US Patent # 6,646,463 Impedance Emulator Patent issued to PulseCore Semiconductor, dated 11-11-2003

**ON Semiconductor** and  are registered trademarks of Semiconductor Components Industries, LLC (SCILLC). SCILLC reserves the right to make changes without further notice to any products herein. SCILLC makes no warranty, representation or guarantee regarding the suitability of its products for any particular purpose, nor does SCILLC assume any liability arising out of the application or use of any product or circuit, and specifically disclaims any and all liability, including without limitation special, consequential or incidental damages. "Typical" parameters which may be provided in SCILLC data sheets and/or specifications can and do vary in different applications and actual performance may vary over time. All operating parameters, including "Typicals" must be validated for each customer application by customer's technical experts. SCILLC does not convey any license under its patent rights nor the rights of others. SCILLC products are not designed, intended, or authorized for use as components in systems intended for surgical implant into the body, or other applications intended to support or sustain life, or for any other application in which the failure of the SCILLC product could create a situation where personal injury or death may occur. Should Buyer purchase or use SCILLC products for any such unintended or unauthorized application, Buyer shall indemnify and hold SCILLC and its officers, employees, subsidiaries, affiliates, and distributors harmless against all claims, costs, damages, and expenses, and reasonable attorney fees arising out of, directly or indirectly, any claim of personal injury or death associated with such unintended or unauthorized use, even if such claim alleges that SCILLC was negligent regarding the design or manufacture of the part. SCILLC is an Equal Opportunity/Affirmative Action Employer. U.S. Patent Pending; Timing-Safe and Active Bead are trademarks of PulseCore Semiconductor, a wholly owned subsidiary of ON Semiconductor. This literature is subject to all applicable copyright laws and is not for resale in any manner.

## PUBLICATION ORDERING INFORMATION

### LITERATURE FULFILLMENT:

Literature Distribution Center for ON Semiconductor  
P.O. Box 5163, Denver, Colorado 80217 USA  
**Phone:** 303-675-2175 or 800-344-3860 Toll Free  
USA/Canada  
**Fax:** 303-675-2176 or 800-344-3867 Toll Free  
USA/Canada  
**Email:** [orderlit@onsemi.com](mailto:orderlit@onsemi.com)

**N. American Technical Support:** 800-282-9855  
Toll Free USA/Canada  
**Europe, Middle East and Africa Technical Support:**  
Phone: 421 33 790 2910  
**Japan Customer Focus Center**  
Phone: 81-3-5773-3850

**ON Semiconductor Website:**  
[www.onsemi.com](http://www.onsemi.com)

**Order Literature:** <http://www.onsemi.com/orderlit>

For additional information, please contact your local Sales Representative