

Marketing Bulletin

DATE: January 28th, 2008
TO: All Sales Personnel
FROM: Isaac Gonzalez
RE: Product Termination

To all concerned parties,

This bulletin is to notify all customers of the discontinuation of the following Ecliptek series effective January 28th, 2008:

Series	Description	Recommended Replacement
E3U	RoHS Compliant (Pb-free) Resistance Welded HC-49/UST Crystal	E2S Series

In compliance with our End of Life (EOL) policy, this will serve as advanced notice of product termination. New orders will not be accepted after July 28th, 2008, with delivery to conclude by October 28th, 2008.

If there are any questions pertaining to this bulletin, please feel free to contact me. Thank you again for your cooperation.

Best Regards,



Isaac Gonzalez
Configuration Manager
Ecliptek Corporation

E3U Series

- RoHS Compliant (Pb-Free)
- HC-49/UST package
- AT or BT cut available
- Resistance weld seal
- Tight tolerance/stability
- Insulator tab, and custom lead length options available

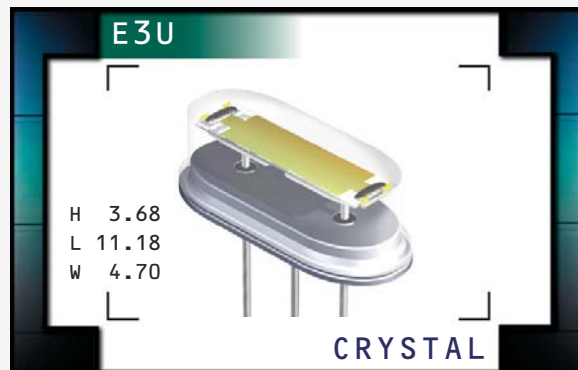

NOTES

OBSOLETE

ELECTRICAL SPECIFICATIONS

Frequency Range	3.579545MHz to 50.000MHz
Frequency Tolerance / Stability	±50ppm / ±100ppm (Standard), ±30ppm / ±50ppm (AT cut only), ±15ppm / ±30ppm (AT cut only),
Over Operating Temperature Range	±15ppm / ±20ppm (AT cut only), or ±10ppm / ±15ppm (AT cut only)
Operating Temperature Range	0°C to 70°C (Standard), -20°C to 70°C (AT cut only), or -40°C to 85°C (AT cut only)
Aging (at 25°C)	±5ppm / year Maximum
Storage Temperature Range	-40°C to 85°C
Shunt Capacitance	7pF Maximum
Insulation Resistance	500 Megaohms Minimum at 100V _{DC}
Drive Level	1 mWatt Maximum
Load Capacitance (C _L)	18pF (Standard), Custom C _L ≥10pF, or Series Resonant
Drive Level Dependency (DLD2)	20% of Maximum ESR Limit (from 1μWatt to 1000μWatts)
Spurious Response	>3dB from F _o to F _o +5000ppm

EQUIVALENT SERIES RESISTANCE (ESR), MODE OF OPERATION (MODE), AND CUT

Frequency Range	ESR (Ω)	Mode / Cut	Frequency Range	ESR (Ω)	Mode / Cut
3.579545MHz to 4.999MHz	200 Max	Fundamental / AT	15.000MHz to 15.999MHz	60 Max	Fundamental / AT
5.000MHz to 5.999MHz	150 Max	Fundamental / AT	16.000MHz to 23.999MHz	50 Max	Fundamental / AT
6.000MHz to 7.999MHz	120 Max	Fundamental / AT	24.000MHz to 29.4912MHz	40 Max	Fundamental / AT
8.000MHz to 8.999MHz	90 Max	Fundamental / AT	24.000MHz to 40.000MHz	40 Max	Fundamental / BT
9.000MHz to 9.999MHz	80 Max	Fundamental / AT	28.6363MHz to 29.999MHz	150 Max	Third Overtone / AT
10.000MHz to 14.999MHz	70 Max	Fundamental / AT	30.000MHz to 50.000MHz	100 Max	Third Overtone / AT

MANUFACTURER
ECLIPTEK CORP.

CATEGORY
CRYSTAL

SERIES
E3U

PACKAGE
HC-49/UST

CLASS
CR45

REV. DATE
03/04

PART NUMBERING GUIDE

E3U A A 18 - 30.000M - I2

FREQUENCY TOLERANCE / STABILITY

A=±50ppm at 25°C, ±100ppm from 0°C to 70°C
 B=±50ppm at 25°C, ±100ppm from -20°C to 70°C
 C=±50ppm at 25°C, ±100ppm from -40°C to 85°C
 D=±30ppm at 25°C, ±50ppm from 0°C to 70°C
 E=±30ppm at 25°C, ±50ppm from -20°C to 70°C
 F=±30ppm at 25°C, ±50ppm from -40°C to 85°C
 G=±15ppm at 25°C, ±30ppm from 0°C to 70°C
 H=±15ppm at 25°C, ±30ppm from -20°C to 70°C
 J=±15ppm at 25°C, ±30ppm from -40°C to 85°C
 K=±15ppm at 25°C, ±20ppm from 0°C to 70°C
 L=±15ppm at 25°C, ±20ppm from -20°C to 70°C
 * M=±15ppm at 25°C, ±20ppm from -40°C to 85°C
 * N=±10ppm at 25°C, ±15ppm from 0°C to 70°C
 * P=±10ppm at 25°C, ±15ppm from -20°C to 70°C

AVAILABLE OPTIONS

Blank=None (Std)
 CD=Custom Lead Length (3.810 ±0.500mm)
 CE=Custom Lead Length (4.445 ±0.500mm)
 I2=Insulator Tab

FREQUENCY

LOAD CAPACITANCE

S=Series
 XX=XXpF (Custom)

MODE OF OPERATION / CRYSTAL CUT

A=Fundamental / AT
 B=Third Overtone / AT
 D=Fundamental / BT

* Frequency Tolerance/Stability options M, N, and P are only available with frequencies greater than 10.000MHz

NOTES

OBSOLETE

MECHANICAL DIMENSIONS ALL DIMENSIONS IN MILLIMETERS

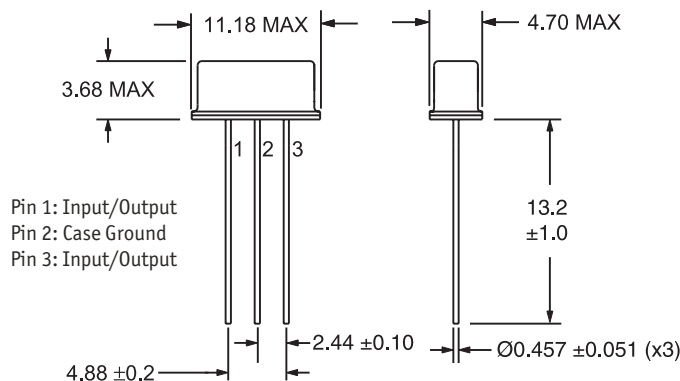

ENVIRONMENTAL/MECHANICAL SPECIFICATIONS

PARAMETER

Fine Leak Test
 Gross Leak Test
 Lead Integrity
 Lead Termination
 Mechanical Shock
 Resistance to Soldering Heat
 Resistance to Solvents
 Solderability
 Temperature Cycling
 Vibration

SPECIFICATION

MIL-STD-883, Method 1014, Condition A
 MIL-STD-883, Method 1014, Condition C
 MIL-STD-883, Method 2004
 Sn 2µm - 6µm
 MIL-STD-202, Method 213, Condition C
 MIL-STD-202, Method 210
 MIL-STD-202, Method 215
 MIL-STD-883, Method 2002
 MIL-STD-883, Method 1010
 MIL-STD-883, Method 2007, Condition A

MARKING SPECIFICATIONS

Line 1: E XX.XXX M
 Frequency in MHz
 (5 Digits Maximum + Decimal)

MANUFACTURER
 ECLIPTEK CORP.

CATEGORY
 CRYSTAL

SERIES
 E3U

PACKAGE
 HC-49/UST

CLASS
 CR45

REV. DATE
 03/04