

Thin film, high frequency inductors

THL (0402; 0603)

FEATURES

- High tolerance, ± 0.2 nH and $\pm 2\%$
- High Q
- High SRF
- Low DC resistance
- Excellent RF stability
- Low profile.

APPLICATIONS

- Cellular handsets
- Cordless telephones
- Base stations
- W-LAN
- GPS
- Tuners
- Satellite TV
- CATV.

DESCRIPTION

The body of the inductor consists of a ceramic substrate on which a low resistive planar inductor is grown. The inductor is patterned very accurately by means of photolithography. Thin-film terminations are added and connected to the inductor.

The terminations are covered with a tin layer for ease of soldering.

QUICK REFERENCE DATA

DESCRIPTION	VALUE	
	THL0603	THL0402
Size code	0603 (1608)	0402 (1005)
Inductance range	1.0 to 100 nH	1.0 to 39 nH
Tolerance on inductance (E12 series):		
$1.0 \leq L \leq 8.2$ nH	± 0.2 nH	± 0.2 nH
$10 < L \leq 15$ nH	$\pm 2\%$	$\pm 2\%$
$L > 15$ nH	$\pm 2\%$	$\pm 3\%$
Temperature coefficient	0 to $+125 \times 10^{-6}/K$	
Operating temperature	-55 °C to +125 °C	

Thin film, high frequency inductors

THL (0402; 0603)

ORDERING INFORMATION

Components may be ordered by using a simple 13-digit clear text code or Philips unique 12NC.

Clear text code (preferred)**Composition of the clear text code**

TYPE	SIZE	VALUE ⁽¹⁾	TOL.	PACKAGING ⁽²⁾
				PAPER TAPE ON Ø180 mm REEL
THL	0603	1N0 = 1 nH	C = ±0.2 nH	B1 = 5 000 units
	0402		G = ±2%	B2 = 10 000 units
			H = ±3%	

Notes

- For values up to 8.2 nH the letter N is used as a decimal point. For values of 10 nH or greater the first 2 digits apply to the inductance value and the third indicates the number of zeros to follow.
- Inductors in size 0603 are available only in quantities of 5000 units per reel. Inductors in size 0402 are available only in quantities of 10000 units per reel.

EXAMPLE

The ordering code of a thin film 0603 inductor, value 4.7 nH with a tolerance of 0.2 nH, supplied on paper tape of 5 000 units per reel is: THL06034N7CB1.

Thin film, high frequency inductors

THL (0402; 0603)

Ordering code (12NC)

The inductors have a 12-digit ordering code that can be logically constructed using Tables 1 and 2. Case size 0603 is only available in 5000 units per reel. Case size 0402 is available in 10000 units per reel.

- The code starts with 9365
- The subsequent 3 digits indicate case size and packaging quantity; see Table 1.
- The following 3 digits are always 122
- The last 2 digits indicate the inductance value in accordance with Table 2.

Table 1 Three digits to indicate case size and packaging quantity

TYPE	ORDERING CODE 9365	
	PAPER TAPE ON Ø180 mm REEL	
	5 000 UNITS	10 000 UNITS
THL0603	006 122..	–
THL0402	–	007 122..

Table 2 Last digits of 12NC

ORDERING CODE 9365			
INDUCTANCE VALUE (nH)	LAST TWO DIGITS	RANGE	
		0603	0402
1.0	11		
1.2	13		
1.5	15		
1.8	17		
2.2	19		
2.7	22		
3.3	24		
3.9	26		
4.7	28		
5.6	31		
6.8	33		
8.2	35	Shaded cells indicate product range.	
10	37		
12	39		
15	42		
18	44		
22	46		
27	48		
33	51		
39	53		
47	55		
56	57		
68	59		
82	62		
100	64		

ORDERING EXAMPLE

The ordering code of a thin film 0603 inductor, value 4.7 nH with a tolerance of 0.2 nH, on paper tape of 5 000 units per reel is: 9365 00 6 122 28.

Thin film, high frequency inductors

THL (0402; 0603)

FUNCTIONAL DESCRIPTION

Product characterization

Table 3 Available range and relevant electrical data for 0603 size

L (nH)	TOL.	Q			SRF (GHz)	R _{DC} (Ω)	I _R (mA)
		MIN. at 300 MHz	TYPICAL at 800 MHz	TYPICAL at 1.5 GHz	MIN.	MIN.	
1.0	±0.2 nH	20	34	38	6.0	0.10	1000
1.2							
1.5							
1.8							
2.2							
2.7							
3.3		30	35	5.0	0.15	800	
3.9							
4.7							
5.6							
6.8							
8.2	±2%	15	25	3.0	0.20	700	
10							
12							
15							
18		15 ⁽¹⁾	25	2.0	0.25	600	
22							
27							
33							
39							
47							
56	10 ⁽¹⁾	15	1.0	0.50	400		
68							
82							
100							
				4.0	1.00	300	
				3.0	1.50	250	
				2.0	2.00	200	
				1.5	3.00	180	
				1.0	4.00	150	
				1.0	4.50	140	
				1.0	6.00	120	
				1.0	8.50	100	

Note

1. Measured at 200 MHz

Thin film, high frequency inductors

THL (0402; 0603)

Table 4 Available range and relevant electrical data for 0402 size

L (nH)	TOL.	Q			SRF (GHz)	R _{DC} (Ω)	I _R (mA)	
		MIN. at 300 MHz	TYPICAL at 800 MHz	TYPICAL at 1.5 GHz	MIN.	MIN.		
1.0	±0.2 nH	10	21	25	7.0	0.10	1200	
1.2						0.15		930
1.5						730		
1.8							600	
2.2						0.20		580
2.7						500		
3.3				420				
3.9					340			
4.7				320				
5.6					290			
6.8				230				
8.2					210			
10	±2%	20	20	4.0		1.50	190	
12					160			
15						150		
18	±3%	10 ⁽¹⁾	-	1.5	2.55		130	
22					120			
27						2.70		
33	4.00							
39		4.00						

Note

1. Measured at 200 MHz.

Thin film, high frequency inductors

THL (0402; 0603)

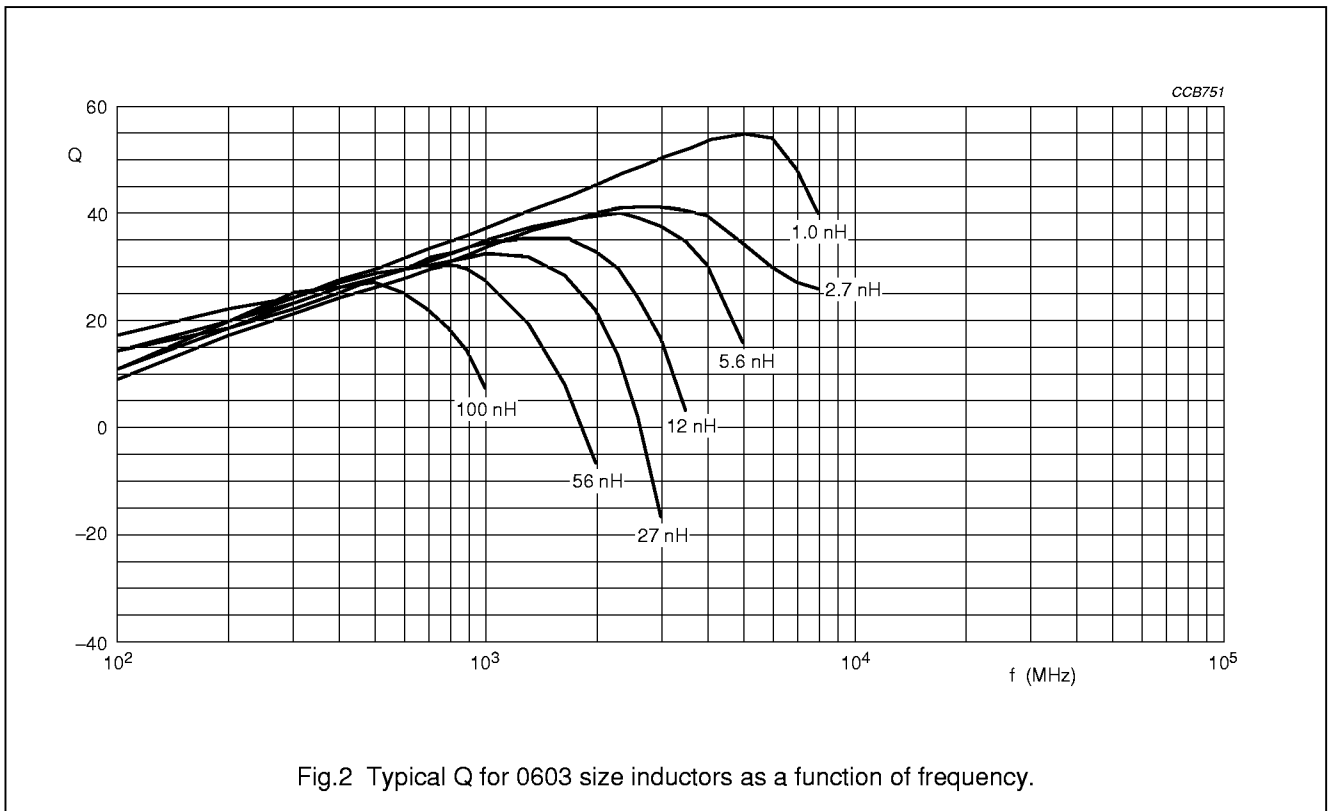
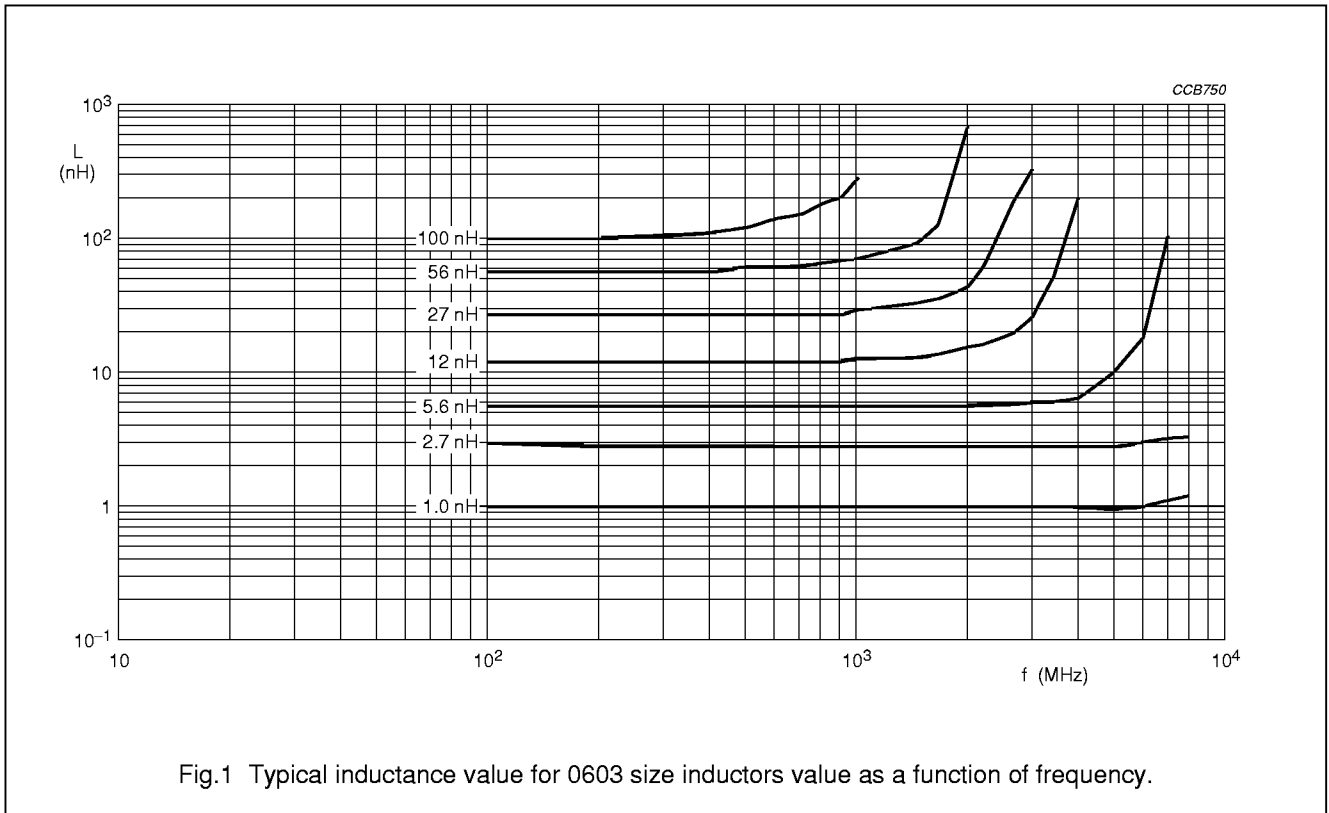

Thin film, high frequency inductors

THL (0402; 0603)

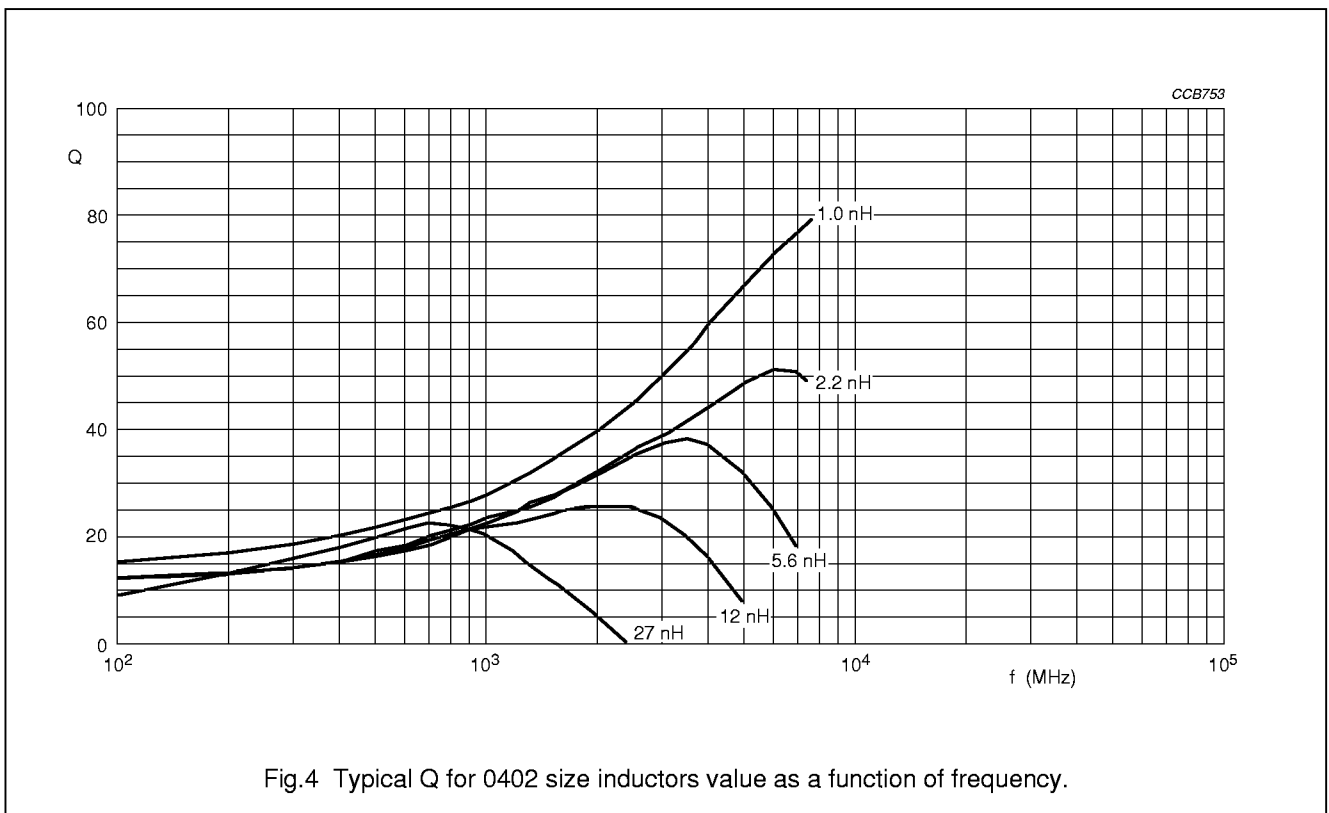
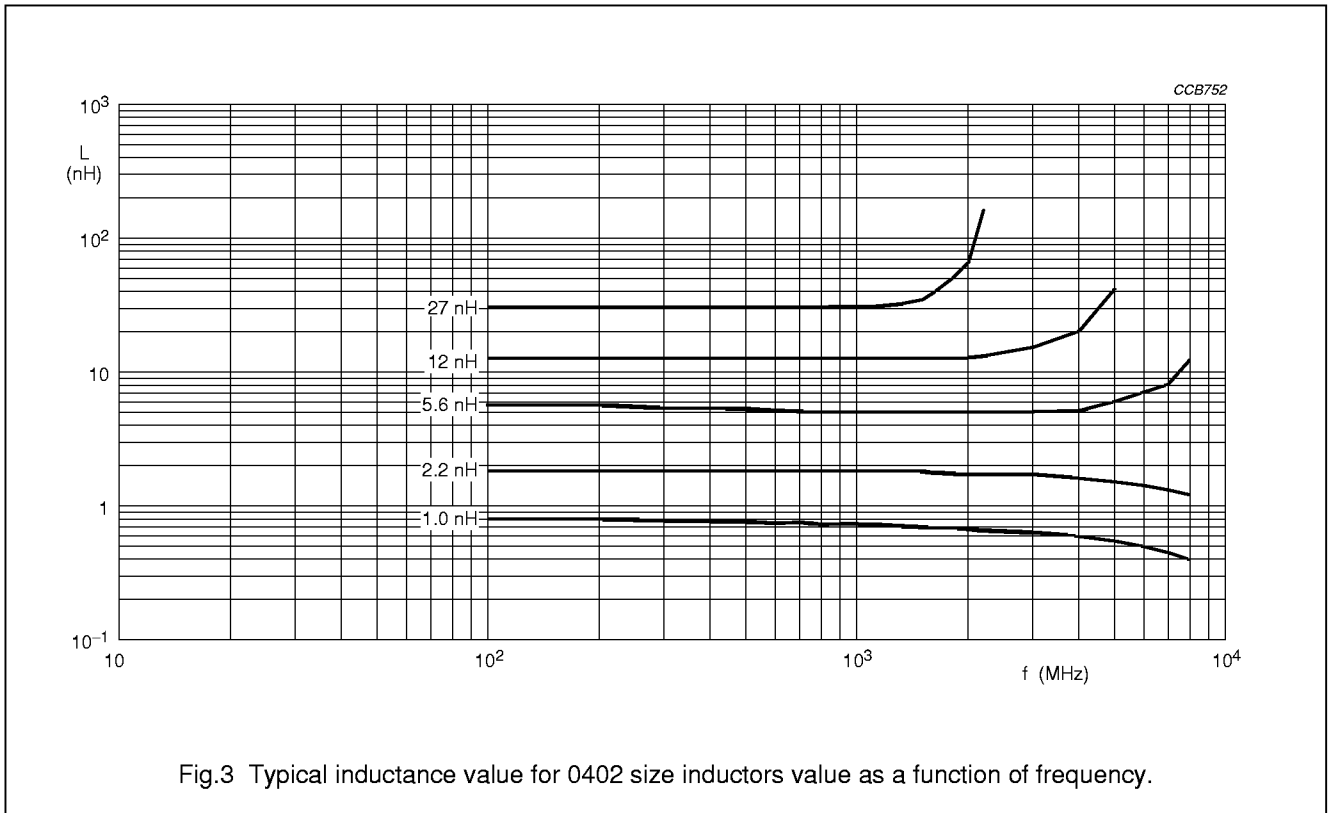

Thin film, high frequency inductors

THL (0402; 0603)

MECHANICAL DATA

Marking

PACKAGE MARKING

The reel and package are marked with inductance value, tolerance, class, catalogue number, quantity, production period, batch number and source code.

Outlines

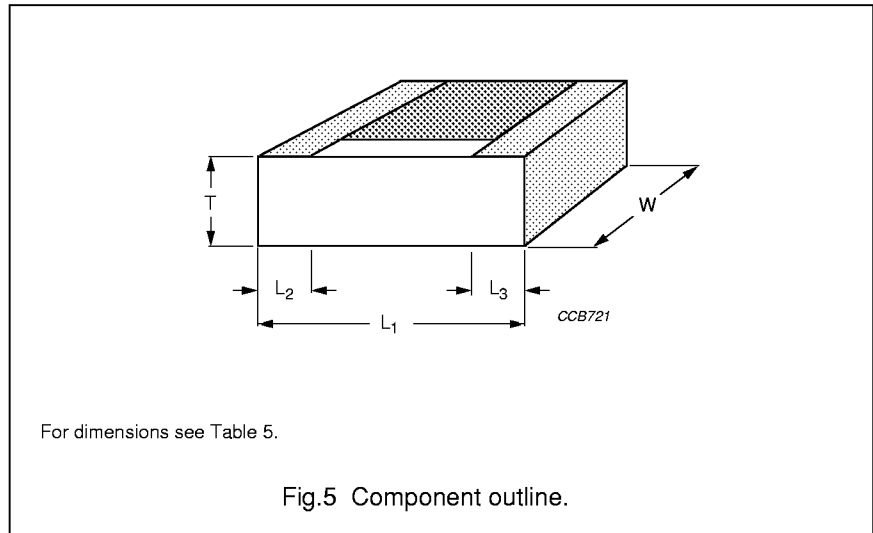

Table 5 Inductor dimensions; see Fig.5

CASE SIZE	L ₁ (mm)	W (mm)	T (mm)	L ₂ (mm)	L ₃ (mm)
0402	1.0 ±0.1	0.5 ±0.1	0.4 ±0.1	0.25 ±0.05	0.25 ±0.05
0603	1.6 ±0.1	0.8 ±0.1	0.45 ±0.1	0.3 ±0.2	0.3 ±0.2

Thin film, high frequency inductors

THL (0402; 0603)

TESTS AND REQUIREMENTS**Table 6** Test procedures and requirements

TEST	PROCEDURE	REQUIREMENTS
Mounting	the inductors may be mounted on printed-circuit boards (PCBs) or ceramic substrates by applying reflow soldering or conductive adhesive	no visible damage
Visual inspection and dimension check	any applicable method using $\times 10$ magnification	in accordance with specification
Mechanical performance		
Resistance to soldering heat	260 ± 5 °C for 10 +0.5 s in a static soldering bath	no visible damage $\Delta L/L_{\max.} : \pm 5\%$ $\Delta Q/Q_{\max.} : \pm 10\%$ ($L \geq 10$ nH) $\Delta Q/Q_{\max.} : \pm 20\%$ ($L < 10$ nH)
Solderability	unmounted chips completely immersed for 2 +0.5 s in a soldering bath at 235 ± 5 °C	good tinning (>95% covered), no visible damage
Environmental performance		
Endurance at 70 °C	1 000 hours at 70 °C, loaded with I_{rated} , 1.5 hours on, 0.5 hours off	no visible damage $\Delta L/L_{\max.} : \pm 5\%$ $\Delta Q/Q_{\max.} : \pm 10\%$ ($L \geq 10$ nH) $\Delta Q/Q_{\max.} : \pm 20\%$ ($L < 10$ nH)
Rapid change of temperature	-55 to $+125$ °C, 50 cycles	no visible damage $\Delta L/L_{\max.} : \pm 5\%$ $\Delta Q/Q_{\max.} : \pm 10\%$ ($L \geq 10$ nH) $\Delta Q/Q_{\max.} : \pm 20\%$ ($L < 10$ nH)
Loaded, damp heat, steady state (JIS)	1 000 hours at 40 °C; 90 to 95% RH; loaded with I_{rated} , 1.5 hours on, 0.5 hours off	no visible damage $\Delta L/L_{\max.} : \pm 5\%$ $\Delta Q/Q_{\max.} : \pm 10\%$ ($L \geq 10$ nH) $\Delta Q/Q_{\max.} : \pm 20\%$ ($L < 10$ nH)