

## 128K x 32 SRAM SRAM MEMORY ARRAY

### AVAILABLE AS MILITARY SPECIFICATIONS

- SMD 5962-95595: -Q
- SMD 5962-93187: -P or -PN
- MIL-STD-883

### FEATURES

- Access times of 15, 17, 20, 25, 35, and 45 ns
- Built in decoupling caps for low noise operation
- Organized as 128K x32; User configured as 256Kx16 or 512K x8
- Operation with single 5 volt supply
- Low power CMOS
- TTL Compatible Inputs and Outputs
- 2V Data Retention, Low power standby

### OPTIONS

- Timing
  - 15ns
  - 17ns
  - 20ns
  - 25ns
  - 35ns
  - 45ns

### MARKINGS

-15	Q	No. 702
-17	Q1	
-20		
-25		
-35	P	No. 802
-45	PN	No. 802

NOTE: PN indicates a no connect on pins 8, 21, 28, 39

### GENERAL DESCRIPTION

The AS8S128K32 is a 4 Megabit CMOS SRAM Module organized as 128Kx32-bits and user configurable to 256Kx16 or 512Kx8. The AS8S128K32 achieves high speed access, low power consumption and high reliability by employing advanced CMOS memory technology.

The military temperature grade product is suited for military applications.

The AS8S128K32 is offered in a ceramic quad flatpack module per SMD-5962-95595 with a maximum height of 0.140 inches. This module makes use of a low profile, multichip module design.

This device is also offered in a 1.075 inch square ceramic pin grid array per SMD 5692-93187, which has a maximum height of 0.195 inches. This package is also a low profile, multi-chip module design reducing height requirements to a minimum.

For more products and information

please visit our web site at

[www.micross.com](http://www.micross.com)

### PIN ASSIGNMENT

(Top View)

68 Lead CQFP (Q & Q1)

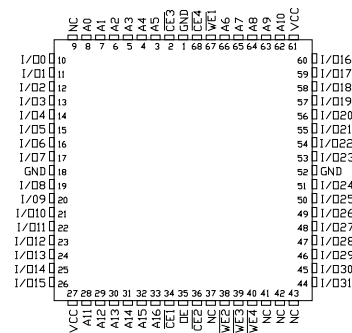

66 Lead PGA- Pins 8, 21, 28, 39 are grounds (P)

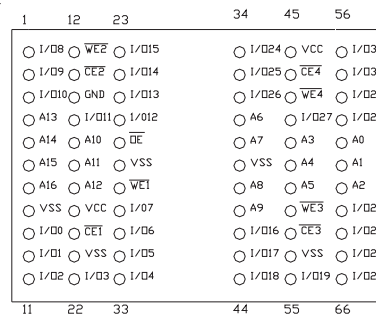

66 Lead PGA- Pins 8, 21, 28, 39 are no connects (PN)

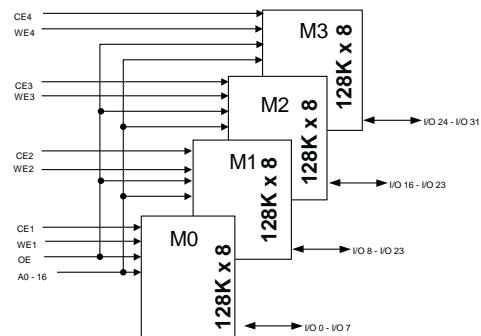
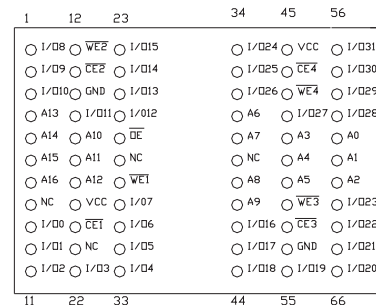

**ABSOLUTE MAXIMUM RATINGS\***

Voltage of Vcc Supply Relative to Vss.....-1V to +7V  
 Storage Temperature.....-65°C to +150°C  
 Short Circuit Output Current(per I/O).....20mA  
 Voltage on Any Pin Relative to Vss.....-5V to Vcc+1V  
 Maximum Junction Temperature\*\*.....+175°C

\*Stresses greater than those listed under “Absolute Maximum Ratings” may cause permanent damage to the device.

This is a stress rating only and functional operation on the device at these or any other conditions above those indicated in the operational sections of this specification is not implied. Exposure to absolute maximum rating conditions for extended periods may affect reliability.

\*\*Junction temperature depends upon package type, cycle time, loading, ambient temperature and airflow. See the Application Information section at the end of this datasheet for more information.

**ELECTRICAL CHARACTERISTICS AND RECOMMENDED DC OPERATING CONDITIONS**

(-55°C ≤ TA ≤ 125°C; Vcc = 5v ± 10%)

PARAMETER	CONDITIONS	SYMBOL	MIN	MAX	UNITS	NOTES
Input High (Logic 1) Voltage		V <sub>IH</sub>	2.2	V <sub>CC</sub> +0.5	V	1
Input Low (Logic 0) Voltage		V <sub>IL</sub>	-0.5	0.8	V	1, 2
INPUT LEAKAGE CURRENT ADD, OE	OV < V <sub>IN</sub> < V <sub>CC</sub>	I <sub>L1</sub>	-10	-10	µA	
INPUT LEAKAGE CURRENT WE, CE	OV < V <sub>IN</sub> < V <sub>CC</sub>	I <sub>L2</sub>	-5	5	µA	
OUTPUT LEAKAGE CURRENT I/O	Outputs(s) Disabled OV < V <sub>OUT</sub> < V <sub>CC</sub>	I <sub>LO</sub>	-5	5	µA	
Output High Voltage	I <sub>OH</sub> = -4.0mA	V <sub>OH</sub>	2.4	--	V	1
Output Low Voltage	I <sub>OL</sub> = 8.0mA	V <sub>OL</sub>	--	0.4	V	1
Supply Voltage		V <sub>CC</sub>	4.5	5.5	V	1

PARAMETER	CONDITIONS	SYM	MAX						UNITS	NOTES
			-15	-17	-20	-25	-35	-45		
Power Supply Current: Operating	CE ≤ V <sub>IL</sub> ; V <sub>CC</sub> = MAX f = MAX = 1/t <sub>RC</sub> (MIN) Outputs Open	I <sub>CC</sub>	700	650	600	560	520	500	mA	3, 13 <sup>(1)</sup>
Power Supply Current: Standby	CE ≥ V <sub>IH</sub> ; V <sub>CC</sub> = MAX f = MAX = 1/t <sub>RC</sub> (MIN) Outputs Open	I <sub>SBT1</sub>	280	220	200	180	160	150	mA	(1)
	CE \ = OE \ = V <sub>IH</sub> ; CMOS Compatible; V <sub>CC</sub> = MAX f = 5 MHz	I <sub>SBT2</sub>	100	80	80	60	60	60	mA	(1)
	CE \ ≥ V <sub>CC</sub> -0.2V; V <sub>CC</sub> = MAX V <sub>IL</sub> ≤ V <sub>SS</sub> +0.2V; V <sub>IH</sub> ≥ V <sub>CC</sub> -0.2V; f = 0 Hz	I <sub>SBC1</sub>	40	40	40	40	40	40	mA	(2)
	CE \ > V <sub>CC</sub> -0.2V; V <sub>CC</sub> = MAX V <sub>IL</sub> < V <sub>SS</sub> +0.2V; V <sub>IH</sub> > V <sub>CC</sub> -0.2V; f = 0 Hz "L" Version Only	I <sub>SBC2</sub>	24	24	24	24	24	24	mA	(2)

**NOTE:** 1) Address switching sequence A, A+1, A+2, etc.  
 2) 1/2 input at HIGH, 1/2 input at LOW.

**CAPACITANCE TABLE** ( $V_{IN} = 0V, f = 1\text{ MHz}, T_A = 25^\circ C$ )

SYMBOL	PARAMETER	MAX	UNITS	NOTES
$C_{ADD}$	A0 - A18 Capacitance	40	pF	4
$C_{OE}$	OE\ Capacitance	40	pF	4
$C_{WE}, C_{CE}$	WE\ and CE\ Capacitance	20	pF	4
$C_{IO}$	I/O 0- I/O 31 Capacitance	20	pF	4

TRUTH TABLE					
MODE	OE\	CE\	WE\	I/O	POWER
Read	L	L	H	Q	ACTIVE
Write	X	L	L	D	ACTIVE
Standby	X	H	X	HIGH Z	STANDBY
Not Selected	H	L	H	HIGH Z	ACTIVE

**AC TEST CONDITIONS**

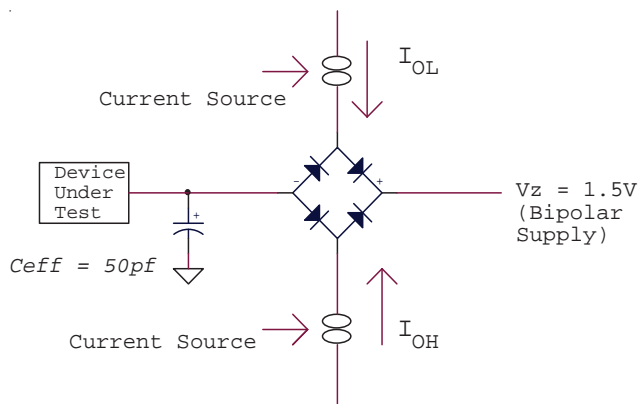

**Figure 1**

**TEST SPECIFICATIONS**

Input pulse levels.....VSS to 3V  
 Input rise and fall times.....5ns  
 Input timing reference levels.....1.5V  
 Output reference levels.....1.5V  
 Output load.....See Figures 1

**NOTES:**

$V_z$  is programmable from -2V to + 7V.  
 $I_{OL}$  and  $I_{OH}$  programmable from 0 to 16 mA.  
 $V_z$  is typically the midpoint of  $V_{OH}$  and  $V_{OL}$ .  
 $I_{OL}$  and  $I_{OH}$  are adjusted to simulate a typical resistive load circuit.

**ELECTRICAL CHARACTERISTICS AND RECOMMENDED AC OPERATING CONDITIONS**  
 (Note 5) (-55°C ≤ TA ≤ 125°C; Vcc = 5v ±10%)

DESCRIPTION	SYMBOL	-15		-17		-20		-25		-35		-45		UNITS	NOTES
		MIN	MAX	MIN	MAX	MIN	MAX	MIN	MAX	MIN	MAX	MIN	MAX		
<b>READ CYCLE</b>															
READ cycle time	<sup>t</sup> RC	15		17		20		25		35		45		ns	
Address access time	<sup>t</sup> AA		15		17		20		25		35		45	ns	
Chip enable access time	<sup>t</sup> ACE		15		17		20		25		35		45	ns	
Output hold from address change	<sup>t</sup> OH	2		2		2		2		2		2		ns	
Chip enable to output in Low-Z	<sup>t</sup> LZCE	2		2		2		2		2		2		ns	4, 6, 7
Chip disable to output in High-Z	<sup>t</sup> HZCE		7		8		9		10		14		15	ns	4, 6, 7
Chip enable to power-up time	<sup>t</sup> PU	0		0		0		0		0		0			4
Chip disable to power-down time	<sup>t</sup> PD		15		17		20		25		35		45		4
Output enable access time	<sup>t</sup> AOE		6		7		7		8		12		12	ns	
Output enable to output in Low-Z	<sup>t</sup> LZOE	0		0		0		0		0		0		ns	4, 6
Output disable to output in High-Z	<sup>t</sup> HZOE		6		7		7		9		12		12	ns	4, 6, 7
<b>WRITE CYCLE</b>															
WRITE cycle time	<sup>t</sup> WC	15		17		20		25		35		45		ns	
Chip enable to end of write	<sup>t</sup> CW	12		12		15		17		20		22		ns	
Address valid to end of write	<sup>t</sup> AW	12		12		15		17		20		22		ns	
Address setup time	<sup>t</sup> AS	0		0		0		0		0		0		ns	
Address hold from end of write	<sup>t</sup> AH	1		1		1		1		1		1		ns	
WRITE pulse width	<sup>t</sup> WP1	12 <sup>1</sup>		12 <sup>1</sup>		15		17		20		20		ns	
WRITE pulse width	<sup>t</sup> WP2	12 <sup>1</sup>		12 <sup>1</sup>		15		17		20		20		ns	
Data setup time	<sup>t</sup> DS	8		9		10		12		15		15		ns	
Data hold time	<sup>t</sup> DH	1		1		1		1		1		1		ns	
Write disable to output in Low-z	<sup>t</sup> LZWE	2		2		2		2		2		2		ns	4, 6, 7
Write enable to output in High-Z	<sup>t</sup> HZWE		7		9		10		11		14		15	ns	4, 6, 7

**NOTES:**

 1) For OE\ = HIGH condition. For OE\ = LOW condition <sup>t</sup>WP1 = <sup>t</sup>WP2 = 15 ns MIN.

**NOTES**

1. All voltages referenced to  $V_{SS}$  (GND).
2. -3v for pulse width <20ns.
3. ICC is dependent on output loading and cycle rates.  
The specified value applies with the outputs open, and  $f = \frac{1}{RC(MIN)}$  Hz.
4. This parameter is sampled.
5. Test conditions as specified with output loading as shown in Fig. 1 unless otherwise noted.
6.  $t_{HZCE}$ ,  $t_{HZOE}$  and  $t_{HZWE}$  are specified with  $C_L = 5pF$  as in Fig. 2. Transition is measured +/- 200 mV typical from steady state coltage, allowing for actual tester RC time constant.
7. At any given temperature and voltage condition,  $t_{HZCE}$ , is less than  $t_{LZCE}$ , and  $t_{HZWE}$  is less than  $t_{LZWE}$ .
8. ?W/E is HIGH for READ cycle.
9. Device is continuously selected. Chip enables and output enable are held in their active state.
10. Address valid prior to or coincident with latest occurring chip enable.
11.  $t_{RC}$  = READ cycle time.
12. Chip enable (?C/E) and write enable (?W/E) can initiate and terminate a WRITE cycle.
13. 32 bit operation

**DATA RETENTION ELECTRICAL CHARACTERISTICS**

DESCRIPTION	CONDITIONS		SYMBOL	MIN	MAX	UNITS	NOTES
$V_{CC}$ for Retention Data			$V_{DR}$	2	--	V	
Data Retention Current	$CE \geq V_{CC} - 0.2V$	$V_{CC} = 2.0V$	$I_{CCDR}$	--	6	mA	
	$V_{IN} \geq V_{CC} - 0.2V$	$V_{CC} = 3V$	$I_{CCDR}$	--	11.6	mA	
Chip Deselect to Data Retention Time			$t_{CDR}$	0	--	ns	4
Operation Recovery Time			$t_R$	$t_{RC}$		ns	4, 11

**LOW  $V_{CC}$  DATA RETENTION WAVEFORM**

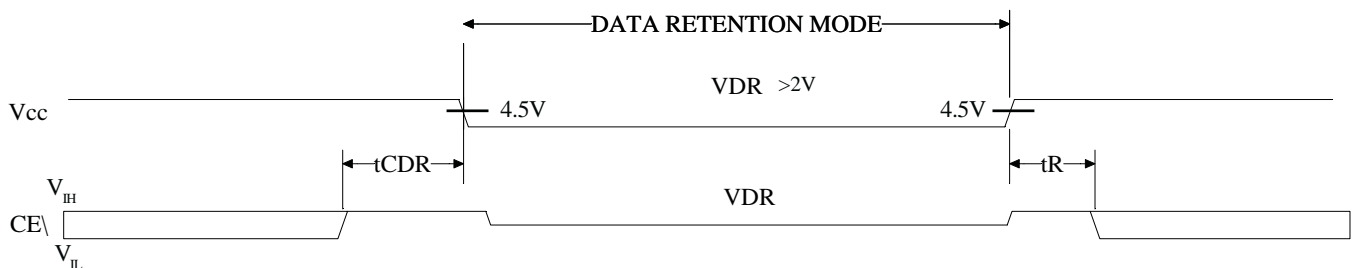

### READ CYCLE NO. 1<sup>(8,9)</sup>

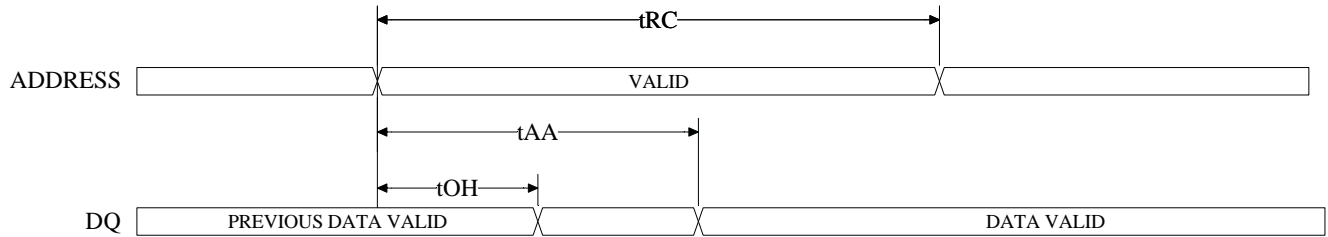

### READ CYCLE NO. 2<sup>(7,8,10)</sup>

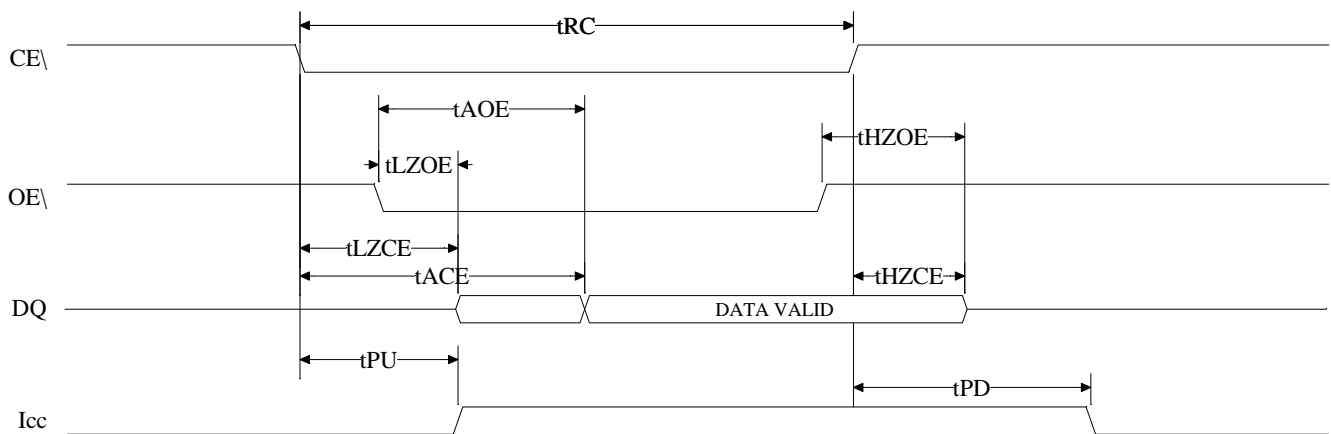

### WRITE CYCLE NO. 1 (Chip Enable Controlled)

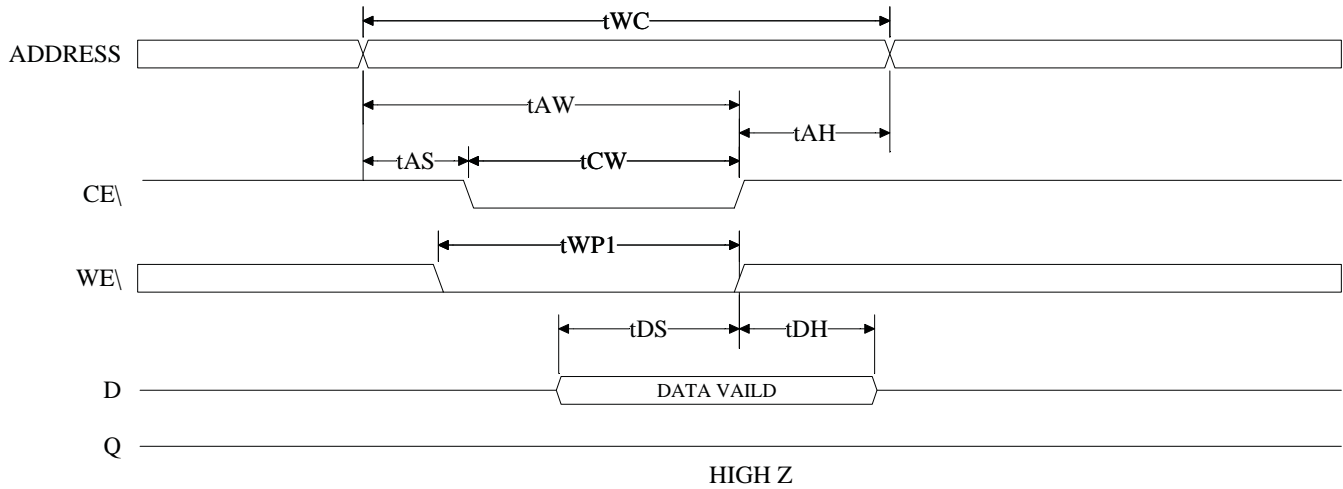

### WRITE CYCLE NO. 2 (Write Enable Controlled)

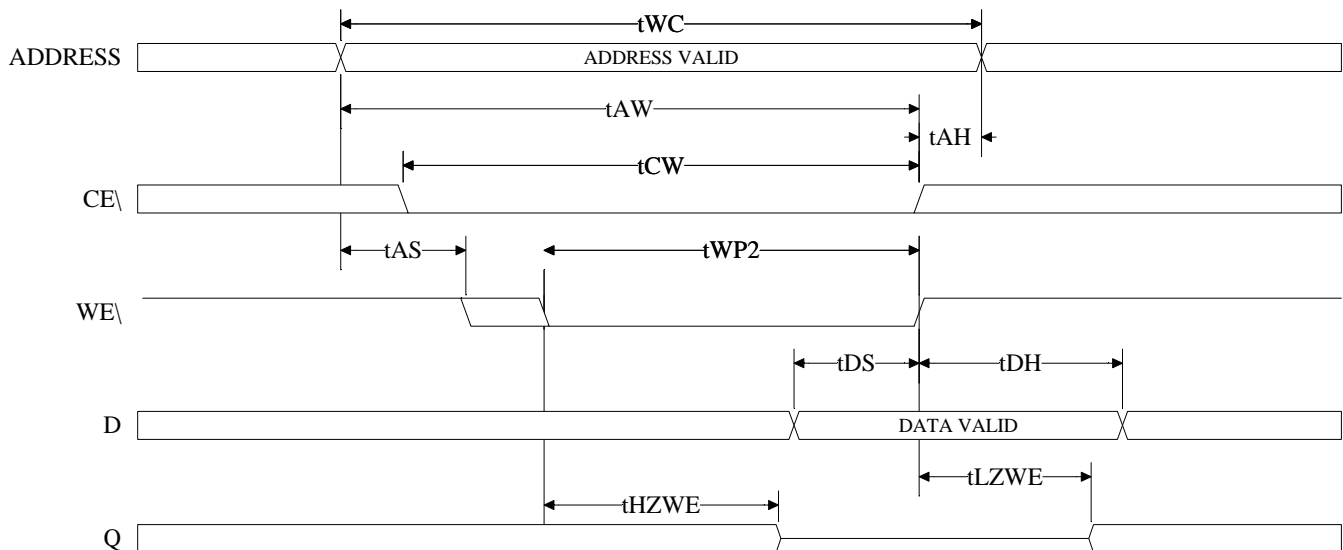



### MECHANICAL DEFINITIONS\*

Micross Case #702 (Package Designator Q)  
SMD 5962-95595, Case Outline M

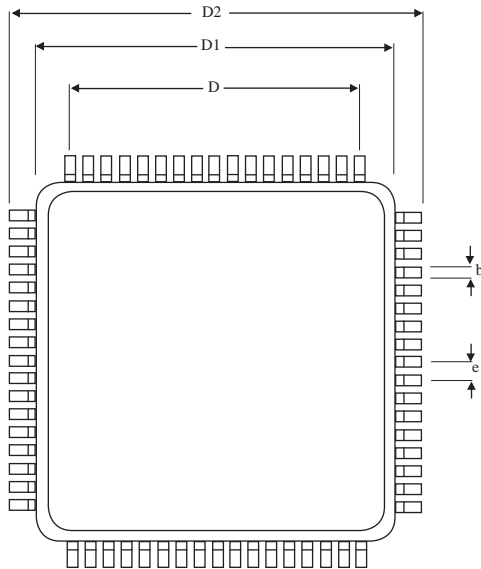

DETAIL A

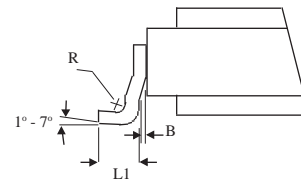

SEE DETAIL A

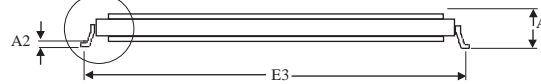

SYMBOL	MICROSS SPECIFICATIONS	
	MIN	MAX
A	0.123	0.200
A1	0.118	0.186
A2	0.005	0.015
B	0.010 REF	
b	0.013	0.017
D	0.800 BSC	
D1	0.870	0.890
D2	0.980	1.000
E	0.936	0.956
e	0.505 BSC	
R	0.010 TYP	
L1	0.035	0.045

\*All measurements are in inches.



## MECHANICAL DEFINITIONS\*

Micross Case (Package Designator Q1)  
SMD 5962-95595, Case Outline A

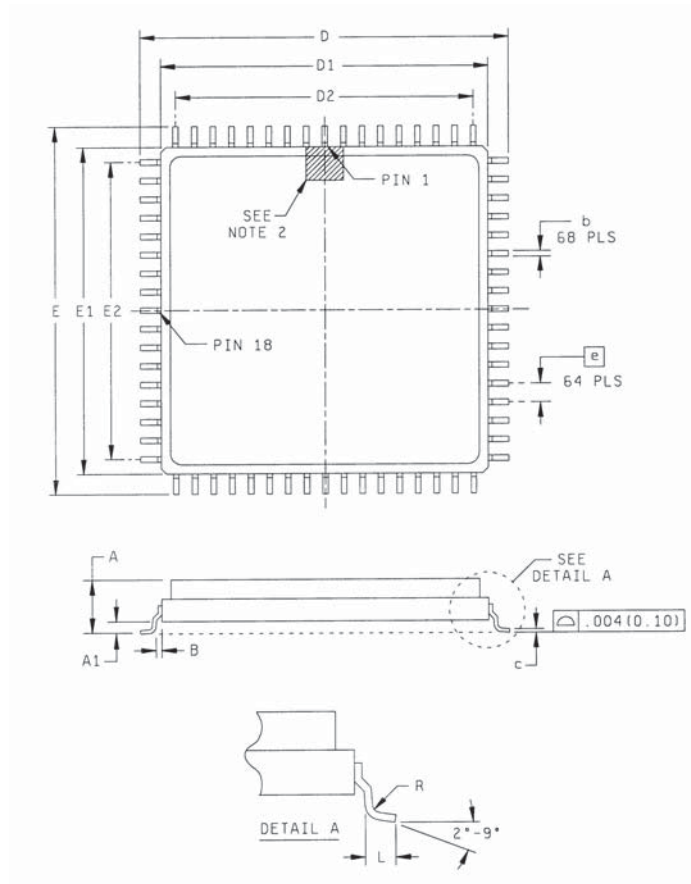

SYMBOL	SMD SPECIFICATIONS	
	MIN	MAX
A	---	0.200
A1	0.054	---
b	0.013	0.017
B	0.010 TYP	
c	0.009	0.012
D/E	0.980	1.000
D1/E1	0.870	0.890
D2/E2	0.800 BSC	
e	0.050 BSC	
L	0.035	0.045
R	0.010 TYP	

\*All measurements are in inches.

## MECHANICAL DEFINITIONS\*

Micross Case #802 (Package Designator P & PN)  
SMD 5962-93187, Case Outline 4 and 5

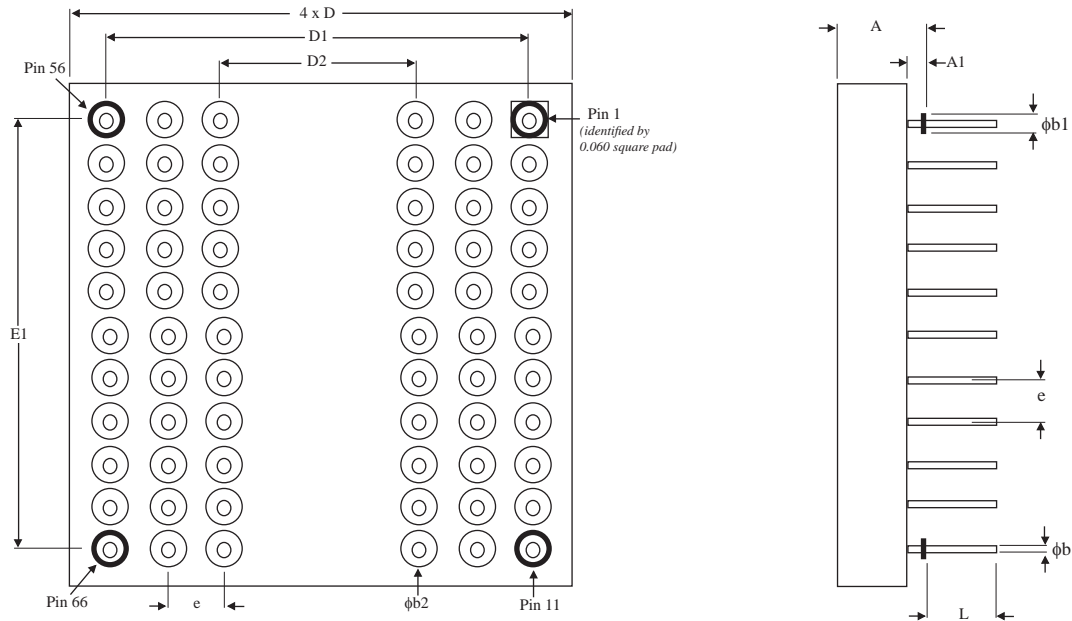

SYMBOL	SMD SPECIFICATIONS	
	MIN	MAX
A	0.135	0.195
A1	0.025	0.035
$\phi b$	0.016	0.020
$\phi b1$	0.045	0.055
$\phi b2$	0.065	0.075
D	1.064	1.086
D1/E1	1.000 BSC	
D2	0.600 BSC	
e	0.100 BSC	
L	0.145	0.155

\*All measurements are in inches.

## ORDERING INFORMATION

EXAMPLE: AS8S128K32Q-25/XT

Device Number	Package Type	Speed ns	Process
AS8S128K32	Q	-15	/*
AS8S128K32	Q	-17	/*
AS8S128K32	Q	-20	/*
AS8S128K32	Q	-25	/*
AS8S128K32	Q	-35	/*
AS8S128K32	Q	-45	/*

EXAMPLE: AS8S128K32Q1-15/IT

Device Number	Package Type	Speed ns	Process
AS8S128K32	Q1	-15	/*
AS8S128K32	Q1	-17	/*
AS8S128K32	Q1	-20	/*
AS8S128K32	Q1	-25	/*
AS8S128K32	Q1	-35	/*
AS8S128K32	Q1	-45	/*

EXAMPLE: AS8S128K32PN-20/883C

Device Number	Package Type	Speed ns	Process
AS8S128K32	P	-15	/*
AS8S128K32	PN	-15	/*
AS8S128K32	P	-17	/*
AS8S128K32	PN	-17	/*
AS8S128K32	P	-20	/*
AS8S128K32	PN	-20	/*
AS8S128K32	P	-25	/*
AS8S128K32	PN	-25	/*
AS8S128K32	P	-35	/*
AS8S128K32	PN	-35	/*
AS8S128K32	P	-45	/*
AS8S128K32	PN	-45	/*

### \*AVAILABLE PROCESSES

IT = Industrial Temperature Range

XT = Extended Temperature Range

883C = Full Military Processing

-40°C to +85°C

-55°C to +125°C

-55°C to +125°C

### PACKAGE NOTES

P = Pins 8, 21, 28, and 39 are grounds.

PN = Pins 8, 21, 28, and 39 are no connects.

## MICROSS TO DSCC PART NUMBER CROSS REFERENCE

### Micross Package Designator Q

<b>Micross Part #</b>	<b>SMD Part #</b>
AS8S128K32Q-55/883C	5962-9559505HMA
AS8S128K32Q-55/883C	5962-9559505HMC
AS8S128K32Q-45/883C	5962-9559506HMA
AS8S128K32Q-45/883C	5962-9559506HMC
AS8S128K32Q-35/883C	5962-9559507HMA
AS8S128K32Q-35/883C	5962-9559507HMC
AS8S128K32Q-25/883C	5962-9559508HMA
AS8S128K32Q-25/883C	5962-9559508HMC
AS8S128K32Q-20/883C	5962-9559509HMA
AS8S128K32Q-20/883C	5962-9559509HMC
AS8S128K32Q-17/883C	5962-9559510HMA
AS8S128K32Q-17/883C	5962-9559510HMC

<b>Micross Part #</b>	<b>SMD Part #</b>
AS8S128K32Q-55/883C	5962-9559512HMA
AS8S128K32Q-55/883C	5962-9559512HMC
AS8S128K32Q-45/883C	5962-9559513HMA
AS8S128K32Q-45/883C	5962-9559513HMC
AS8S128K32Q-35/883C	5962-9559514HMA
AS8S128K32Q-35/883C	5962-9559514HMC
AS8S128K32Q-25/883C	5962-9559515HMA
AS8S128K32Q-25/883C	5962-9559515HMC
AS8S128K32Q-20/883C	5962-9559516HMA
AS8S128K32Q-20/883C	5962-9559516HMC
AS8S128K32Q-17/883C	5962-9559517HMA
AS8S128K32Q-17/883C	5962-9559517HMC

### Micross Package Designator Q1

<b>Micross Part #</b>	<b>SMD Part #</b>
AS8S128K32Q1-55/883C	5962-9559505HAA
AS8S128K32Q1-55/883C	5962-9559505HAC
AS8S128K32Q1-45/883C	5962-9559506HAA
AS8S128K32Q1-45/883C	5962-9559506HAC
AS8S128K32Q1-35/883C	5962-9559507HAA
AS8S128K32Q1-35/883C	5962-9559507HAC
AS8S128K32Q1-25/883C	5962-9559508HAA
AS8S128K32Q1-25/883C	5962-9559508HAC
AS8S128K32Q1-20/883C	5962-9559509HAA
AS8S128K32Q1-20/883C	5962-9559509HAC
AS8S128K32Q1-17/883C	5962-9559510HAA
AS8S128K32Q1-17/883C	5962-9559510HAC

<b>Micross Part #</b>	<b>SMD Part #</b>
AS8S128K32Q1-55/883C	5962-9559512HAA
AS8S128K32Q1-55/883C	5962-9559512HAC
AS8S128K32Q1-45/883C	5962-9559513HAA
AS8S128K32Q1-45/883C	5962-9559513HAC
AS8S128K32Q1-35/883C	5962-9559514HAA
AS8S128K32Q1-35/883C	5962-9559514HAC
AS8S128K32Q1-25/883C	5962-9559515HAA
AS8S128K32Q1-25/883C	5962-9559515HAC
AS8S128K32Q1-20/883C	5962-9559516HAA
AS8S128K32Q1-20/883C	5962-9559516HAC
AS8S128K32Q1-17/883C	5962-9559517HAA
AS8S128K32Q1-17/883C	5962-9559517HAC

### Micross Package Designator P & PN

<b>Micross Part #</b>	<b>SMD Part #</b>
AS8S128K32P-55/883C	5962-9318705H5A
AS8S128K32P-55/883C	5962-9318705H5C
AS8S128K32P-45/883C	5962-9318706H5A
AS8S128K32P-45/883C	5962-9318706H5C
AS8S128K32P-35/883C	5962-9318707H5A
AS8S128K32P-35/883C	5962-9318707H5C
AS8S128K32P-25/883C	5962-9318708H5A
AS8S128K32P-25/883C	5962-9318708H5C
AS8S128K32P-20/883C	5962-9318709H5A
AS8S128K32P-20/883C	5962-9318709H5C
AS8S128K32P-17/883C	5962-9318710H5A
AS8S128K32P-17/883C	5962-9318710H5C

<b>Micross Part #</b>	<b>SMD Part #</b>
AS8S128K32PN-55/883C	5962-9318705H4A
AS8S128K32PN-55/883C	5962-9318705H4C
AS8S128K32PN-45/883C	5962-9318706H4A
AS8S128K32PN-45/883C	5962-9318706H4C
AS8S128K32PN-35/883C	5962-9318707H4A
AS8S128K32PN-35/883C	5962-9318707H4C
AS8S128K32PN-25/883C	5962-9318708H4A
AS8S128K32PN-25/883C	5962-9318708H4C
AS8S128K32PN-20/883C	5962-9318709H4A
AS8S128K32PN-20/883C	5962-9318709H4C
AS8S128K32PN-17/883C	5962-9318710H4A
AS8S128K32PN-17/883C	5962-9318710H4C

*Please note, -15 not currently available on the SMD's.*

**DOCUMENT TITLE**

128K x 32 SRAM, SRAM MEMORY ARRAY

**REVISION HISTORY**

<u>Rev #</u>	<u>History</u>	<u>Release Date</u>	<u>Status</u>
4.2	Updated iCCDR(2V) limit from 6mA to 8mA	June 2008	Release
4.3	Added Micross Information	January 2010	Release