

### Description

The high-speed 0.25  $\mu\text{m}$  drawn (0.18  $\mu\text{m}$  L-effective) EA-C10 embedded array family offers both support for embedded high-density macros as well as the short turnaround time of a gate array resulting in a time-to-market advantage. In this product, NEC combines high-performance CMOS gate array primitives with diffused, embedded megafunctions such as RAM, ROM, CPU, DSP and analog cores.

EA-C10 also uses a cell-based I/O structure that allows a flexible adaptation to the system requirements. State-of-the-art interface macros for high-speed or special signaling systems are also supported, such as PCI, HSTL, GTL+, LVDS, p-ECL, and IEEE1394. Analog functions like DACs, ADCs and PLLs also can be incorporated within the I/O area.

### Process

EA-C10 ASICs are manufactured with NEC's advanced titanium-silicide (Ti-Si) process. The chip layout may use between three and five metal layers (Al). As the EA-C10 ASIC family follows basically a gate array approach, it offers short turnaround times for silicon processing and lower development costs compared to cell-based ASICs. The turnaround time is kept short by fixing the embedded core locations and beginning prototype fabrication in parallel with place and route design steps.

Figure 1. Embedded Array Core Integration

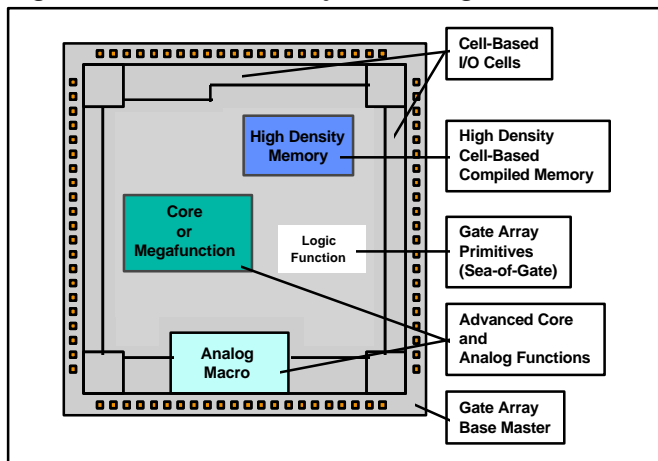

### Applications

The EA-C10 family is ideal for applications where high density is mandatory and a short time-to-market path is required. For example, RAM-dominated designs can be realized with reduced die size and a reasonable turnaround time. EA-C10 is well-suited for designs that may require rework, because the logic function portion of the design uses gate array primitives created just by the final metal masks. Typical applications include engineering workstations, telecommunications systems, advanced graphics and low power applications where very high performance is required.

Table 1. EA-C10 Series Features and Benefits

EA-C10 Series Features	EA-C10 Series Benefits
• 0.25 $\mu\text{m}$ drawn (0.18 $\mu\text{m}$ L-effective) CMOS process	⇒ Ultra-high density cell structure with high performance
• Advanced embedded array architecture	⇒ Fast TAT and high integration of embedded megafunctions
• Available gate counts from 206K to 7 million gates	⇒ Support for a wide range of high-complexity systems
• Optimized 2.5V architecture (operates down to 1.8V)	⇒ Highest speed at ultra-low power consumption
• Significant low power dissipation of 0.14 $\mu\text{W}/\text{MHz}/\text{gate}$	⇒ New application possibilities and new system solutions
• Ultra-high pin count using 40 $\mu\text{m}$ pad pitch	⇒ Increased I/O density to achieve smaller die sizes
• Special power rail structure, multi-oxide process	⇒ Mixed 2.5V / true 3.3V I/O for full system compatibility
• Cell-based I/O structure including LVDS, HSTL, GTL+, PCI	⇒ Flexible adaptation to system requirements
• Embedding of analog macros including DACs, ADCs	⇒ Mixed-signal design options
• Advanced packages such as TapeBGA, Flip Chip+BGA	⇒ Cost-effective and state-of-the-art packaging
• NEC's OpenCAD® design environment	⇒ Flexible design flow for short design times

**Table 2. Product Outline**

Master ( $\mu$ PD69..) 3 layer	..101	..102	..103	..104	..105	..107	..109	..111	..112	..113	..114	..115
Master ( $\mu$ PD69..) 4 layer	..121	..122	..123	..124	..125	..127	..129	..131	..132	..133	..134	..135
Master ( $\mu$ PD69..) 5 layer*	..141	..142	..143	..144	..145	..147	..149	..151	..152	..153	..154	..155
Gate count (available)	206k	338k	497k	690k	1041k	1611k	2127k	2509k	3137k	3597k	4089k	6937k
Number of pads ( $40 \mu\text{m}$ pitch)	348	444	540	636	780	972	1116	1212	1356	1452	1548	2016
Utilization	80% for 3-layer metal; 85% for 4-layer metal											
Toggle frequency (typ.)	1.1 GHz											
Delay time	Internal	59 ps (F/O = 1, L = 0 mm); 147.5 ps (F/O = 2, L = typ. average length) (F322)										
	Input	79.9 ps (F/O = 2, L = 0 mm) (F101)										
	Output	1.363 ns ( $C_L = 50 \text{ pF}$ ) (F002)										
Consumed power	Internal	0.14 $\mu\text{W}/\text{MHz}/\text{gate}$ (2.5V); 0.07 $\mu\text{W}/\text{MHz}/\text{gate}$ (1.8V)										
	Input	1.66 $\mu\text{W}/\text{MHz}$ (F/O = 2, L = 0 mm)										
	Output	167 $\mu\text{W}/\text{MHz}$ ( $C_L = 15 \text{ pF}$ )										
Power supply voltage	2.5 V $\pm$ 0.2V (operation down to 1.8V possible)											
Operating temperature	-40 to +85°C											
Interface level	2.5V / 3.3V CMOS level, LVTTTL level, GTL+,HSTL, PCI, pECL											
Technology	Sea-of-gates $0.25 \mu\text{m}$ (drawn) silicon gate CMOS (0.18 L-effective), diffused embedded macros, 3, 4 or 5* metal layers											

**Note:** \*5th metal layer used for flip-chip packaging

## Interface Macro Support

The EA-C10 interface area uses the cell-based (CB-C10) I/O structures that provide a variety of interface options, including both 2.5-volt and 3.3-volt full-swing interface buffers.

For special applications, several high-speed I/O buffer types are available. These include 3.3-volt PCI cells, AGP for 66 MHz and 133 MHz applications, GTL (Gunning Transceiver Logic), HSTL (class 1,2,3,4) and pseudo-ECL (pECL) buffers. These high-speed buffers are available for special applications. Table 3 summarizes the available interface options.

**2.5-Volt / 3.3-Volt Mixed I/O Interfacing.** Although EA-C10 is a 2.5-volt optimized technology with thin gate oxide, NEC offers 3.3-volt-compatible I/O interfacing. The full-swing 3.3-volt interfacing is achieved through a multi-oxide process in the I/O area. The buffers for 2.5-volt / 3.3-volt interface levels can be mixed. This is supported by the special power rail structure shown in Figure 2.

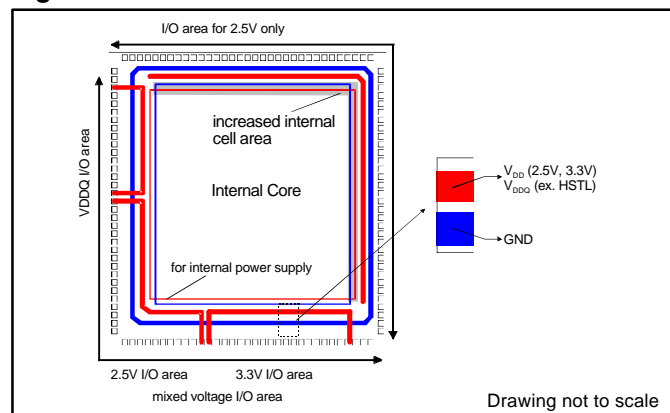
**Figure 2. Power Rail Structure**

**HSTL / PCI Interfacing.** A third power rail ( $V_{DDQ}$ ) is available for interface types that require a reference voltage (such as HSTL, GTL+, and AGP). These buffers may also be located anywhere in the I/O area.

**Table 3. EA-C10 I/O Buffer Types**

Buffer Type	Options and Possible Combinations
Standard I/O Interface Buffers	Pull-up 50 kΩ, 5 kΩ / Pull-down 50 kΩ Schmitt Trigger input Fail safe LVCMOS / LVTTTL level Output buffers: Open drain Tri-state Low noise (slew-rate controlled) Driveability: 2.5V interface: 3, 6, 9, 12, 18, 24 mA/slot 3.3V interface: 3, 6, 9, 12, 24 mA/slot
High-Speed I/O Buffers	PCI (3.3V, up to 64 bit / 66 MHz) GTL / GTL+ pECL HSTL SSTL LVDS* AGP (66 MHz and 133 MHz) IEEE1394* USB*

**Note:** \*Under development. Please check the availability of the advanced interfaces with your nearest NEC design center.

## Block Library Support

EA-C10's functional blocks are designed to be backward-compatible with previous families. Thus, an easy migration from previous designs is possible. The library is fully compatible with CMOS-10, the 0.25 μm (drawn) gate array family.

The EA-C10 family offers a wide variety of advanced blocks, including combinational gates, shift registers, adders and counters. In addition, memory blocks such as RAM and ROM are provided. The EA-C10 primitive macros are available in up to four performance/power options per primitive. With a range of options available, popular design synthesis tools are able to make the optimal size/performance/power choice for each path.

## Macro Library Support

The embedded array approach allows the combination of high-density cores with a prototype turnaround time equal to gate arrays. Megafunctions and memory blocks such as RAM and ROM can be embedded into the sea-of-gates area within the EA-C10 base master. The area used for the megafunctions is defined by pre-diffusion. The logical function is created by the final metalization masks. This enables the usage of a gate array master and the whole set of macros available in the cell-based technology CB-C10. Cores from the BiCMOS family (QB-10) may also be embedded.

**Memory Macros.** Various kinds of memory macros are available for EA-C10. Designers can select either gate array memory compilers using gate array cells or cell-based compilers which offer higher density and faster access times.

Cell-based type memory blocks are generated based on advanced memory compiler tools and thus ensure highest flexibility for design requirements. The available memory types are described in Table 4.

**Table 4. CMOS-10 / EA-C10 Memory Compilers**

Family	Type	Mode	Ports	Maximum Size
CMOS-10/ EA-C10	High-speed	Async.	1	8 Kbit
		Aysnc.	2	8 Kbit
	High-speed	Sync.	2	16 Kbit
		Sync.	3	16 Kbit
EA-C10	High-density	Sync.	1	2K word x 32 bit
		Sync.	2	2K word x 64 bit
	High-speed	Sync.	1	2K word x 64 bit
		Sync.	2	4K word x 64 bit
	Super high-speed	Sync.	1	4K word x 64 bit

All memory macros can be combined with a built-in-self-test (BIST) macro for easy and high-performance production testing.

**Analog Macros.** A variety of A/D and D/A converters will be available for analog applications. Analog-to-digital converters (ADCs) are under development with a bit resolution of 7 to 12 bits and a frequency of 100 kHz (for general-purpose applications) up to 30 MHz. Digital-to-analog converters (DACs) will also be developed with

resolutions of 7 to 12 bits and a frequency of 100 kHz to 220 MHz for high-speed conversion.

**Mega Macros.** NEC offers a large set of megamacros and cores to cope with today's system requirements. Table 5 shows a subset of the macro portfolio.

**Table 5. EA-C10 Mega Macro Library (subset listing)**

Type	Description	Type	Description
CPU	V30MZ™: 16-bit microprocessor	I/F peripheral	71054: programmable timer/counter
CPU	V8xx™: 32-bit RISC microcontroller (several derivatives)	I/F peripheral	71055: programmable parallel interface (3x 8-bit)
CPU	ARM	I/F peripheral	71059: interrupt controller unit
CPU	VR4xxx™: 64-bit RISC microcontroller (several derivatives)	I/F peripheral	ATM (25 MHz, 155 MHz)
Datapath	High-speed multiplier/accumulator	I/F peripheral	CODEC (modem, voice)
DSP	OAK: digital signal processor	I/F peripheral	Ethernet 10/100 base
DSP	PINE: digital signal processor	I/F peripheral	IEEE 1284: bidirectional centronics
DSP	SPRX: digital signal processor	I/F peripheral	IEEE1394: high speed serial bus
I/F peripheral	16550: UART with FIFO and 16450 mode	I/F peripheral	MPEG2
I/F peripheral	4993: 8-bit parallel I/O real-time clock	I/F peripheral	PCI controller
I/F peripheral	71037: DMA Controller	I/F peripheral	RAC: RAMBUS ASIC Cell
I/F peripheral	71051: USART, 300k bit/s, full-duplex	I/F peripheral	USB: Universal Serial Bus interface
		DPLL	Digital PLL (up to 250 MHz)
		APLL	Analog PLL (up to 500 MHz)

## Packaging

The advanced pad pitch of 40 µm allows high-pin-count applications and gives a significant benefit for pad-limited designs. EA-C10, the new high-performance embedded array family, is supported by a variety of advanced packages. For lower pin counts (up to 376 pins), the standard QFP is available, including the heat-spreader package type to improve thermal characteristics.

Package Type	Maximum Pin/Ball Count
Plastic BGA	672
Tape BGA	1088
QFP	376 (0.4 mm pitch)
Flip-Chip	2016
Chip Scale	500

Plastic BGAs with up to 672 balls can help to cope with high-complexity system requirements by providing excellent electrical and thermal characteristics. Tape BGA packages support up to 1088 balls.

NEC expands the package offering continuously with new advanced packages. For high-performance applications with high pin counts, the 2-layer tape BGA with enhanced electrical characteristics is available. Applications that require ultra-dense packages can be realized with the flip-chip package. This technique can also be used for Multi-Chip Module (MCM) structures, where die mounting was previously necessary.

## CAD Support

NEC takes up the challenges of the new ultra-high-density 0.25  $\mu\text{m}$  technology by having close relationships with leading EDA vendors to fulfill the design requirements during the whole design flow.

Fully supported by NEC's sophisticated OpenCAD design framework, EA-C10 maximizes design quality and flexibility while minimizing ASIC design time.

NEC's OpenCAD system allows designers to combine the EDA industry's most popular third-party design tools with proprietary NEC tools, including those for advanced floorplanner, clock tree synthesis, automatic test pattern generation (ATPG), full-timing simulation, accelerated fault grading and advanced place and route algorithms. The latest OpenCAD system is open for sign-off using standard EDA tools. NEC offers RTL- and STA-(Static Timing Analysis) sign-off procedures to shorten the ASIC design cycle of high-complexity designs.

**Support of High-Speed Systems.** High-speed systems require tight control of clock skew on the chip and between devices on a printed circuit board. CB-C10 provides two features to control clock skew: the Digital PLL (DPLL) working at frequencies up to 250 MHz for chip-to-chip skew minimization and Clock Tree Synthesis (CTS). CTS — supported by an NEC proprietary design tool — is used for clock skew management through the automatic insertion of a balanced buffer tree. The clock tree insertion method minimizes large-capacitive trunks and is especially useful with the hierarchical, synthesized design style being used for high-integration devices. RC values for actual net lengths of the clock tree are used for back annotation after place and route operations. A skew as low as  $\pm 60$  ps can be achieved.

**Accurate Design Verification.** Nonlinear timing calculation is a very important requirement of the high-density, deep sub-micron ASIC designs. NEC makes use of the increased accuracy delivered by the nonlinear table look-up delay calculation methodology and offers consistent wire load models to ensure a high accuracy of the design verification.

**Design Rule Check.** A comprehensive design rule check (DRC) program reports design rule violations as well as chip utilization statistics for the design netlist. The generated report contains such information as net counts, total pin and gate counts, and utilization figures.

**Layout.** During design synthesis, wire load models are used to get delay estimations in a very early state of the design flow. In general, there's no need for customers to perform the floorplanning to meet the required timing. During layout, enhanced in-place optimization (IPO) features of the layout tools and engineering change order (ECO) capabilities of the synthesis tools are used to optimize critical timing paths defined by the given timing constraints. This feature can reduce the total design time.

## Test Support

The EA-C10 family supports automatic test generation through a scan test methodology. It includes internal scan, boundary scan (JTAG) and built-in-self-test (BIST) architecture for easy and high-performance production RAM testing. This allows higher fault coverage, easier testing and faster development time.

Test of embedded megamacros is supported from NEC's test bus concept, which allows the use of predefined test pattern sets for integrated core macros.

## Supplemental Publications

This data sheet contains preliminary specifications and operational data for the EA-C10 embedded array family. Additional information is available in NEC's EA-C10 Design Manual, Block Library and other related documents. Please refer also to the CMOS-10 and CB-C10 data sheets to get more information about 0.25  $\mu\text{m}$  gate array and cell-based ASIC products.

Please contact your local NEC design center for additional information; see the back of this data sheet for locations and telephone numbers.

## Absolute Maximum Ratings

Power supply voltage, $V_{DD}$	3.6 V
Input voltage, $V_I$	
2.5V input buffer	3.6 V
3.3V input buffer	4.6 V
Output voltage, $V_O$	
2.5V buffer	3.6 V
3.3V buffer	4.6 V
Latch-up current, $I_{LATCH}$	1 A
Operating temperature, $T_{OPT}$	-40 to +85°C
Storage temperature, $T_{STG}$	-65 to +150°C

## Input / Output Capacitance

$V_{DD}=V_I=0$  V;  $f=1$  MHz

Terminal	Symbol	Typ	Max	Unit
Input	$C_{IN}$	4	6	pF
Output	$C_{OUT}$	4	6	pF
I/O	$C_{I/O}$	4	6	pF

**Note:** Values do not include package pin capacitance.

## Power Consumption

Description	Limits	Unit
Internal cell (@ 2.5V supply voltage, loaded)	0.14	$\mu$ W/MHz
Input block (FI01, F/O=2, L=0)	1.66	$\mu$ W/MHz
Output block (F002 @ 15 pF)	167	$\mu$ W/MHz

## Recommended Operating Conditions

Parameter	Symbol	2.5V Buffer		3.3V Buffer		3.3V PCI		Unit
		Min	Max	Min	Max	Min	Max	
Power supply voltage	$V_{DD}$	2.3	2.7	3.0	3.6	3.0	3.6	V
Junction temperature	$T_J$	-40	+125	-40	+125	-40	+125	°C
Low-level input voltage	$V_{IL}$	0	0.7	-0.5	0.3 $V_{DD}$	-0.5	0.3 $V_{DD}$	V
High-level input voltage	$V_{IH}$	1.7	$V_{DD}$	0.5 $V_{DD}$	$V_{DD}+0.5$	0.5 $V_{DD}$	$V_{DD}+0.5$	V
Input rise or fall time	$t_R, t_F$	0	200	0	200	0	200	ns
Input rise or fall time, Schmitt	$t_R, t_F$	0	10	0	10	0	10	ms

## AC Characteristics

$V_{DD} = 2.5$  V  $\pm$  0.2 V;  $T_J = 0$  to +125°C

Parameter	Symbol	Best	Typ	Worst	Unit	Conditions
Toggle frequency	$f_{TOG}$	2.8	2.0	1.1	GHz	D-F/F; F/O = 1
Delay time						
2-input power - NAND (F322)	$t_{PD}$	30.5	41.1	67.7	ps	F/O = 2; L = 0 mm
	$t_{PD}$	43.6	59.0	96.4	ps	F/O = 1; L = 0.5 mm
Flip-flop (F611)	$t_{PD}$	200	278	465	ps	F/O = 1; L = 0 mm
	$t_{PD}$	242	336	558	ps	F/O = 2; L = 0.5 mm
	$t_{SETUP}$	170	220	340	ps	—
	$t_{HOLD}$	60	50	50	ps	—
Input buffer (FI01)	$t_{PD}$	77.8	103	188	ps	F/O = 1; L = 0.5 mm
	$t_{PD}$	63.0	79.7	144	ps	F/O = 2; L = 0 mm
Input buffer (3.3V) *	$t_{PD}$	190	286	510	ps	F/O = 1; L = 0.5 mm
	$t_{PD}$	173	255	451	ps	F/O = 2; L = 0 mm
Output buffer (12 mA) 2.5V	$t_{PD}$	287	439	779	ps	$C_L = 0$ pF
Output buffer (12 mA) 2.5V	$t_{PD}$	932	1363	2312	ps	$C_L = 50$ pF
Output buffer (12 mA) 3.3V *	$t_{PD}$	457	659	1192	ps	$C_L = 0$ pF
Output buffer (12 mA) 3.3V *	$t_{PD}$	1386	2115	3554	ps	$C_L = 50$ pF
Output rise time (12 mA)	$t_R$	0.73	1.03	1.83	ns	$C_L = 15$ pF; 10-90%
Output fall time (12 mA)	$t_F$	0.75	0.93	1.55	ns	$C_L = 15$ pF; 10-90%

**Note:** \*including delay of level shifter circuit

## DC Characteristics

$V_{DD} = 2.5\text{ V} \pm 0.2\text{ V}$ ;  $T_j = 0\text{ to }+125^\circ\text{ C}$

Parameter	Symbol	Min	Typ	Max	Unit	Conditions
Quiescent current						
<= 2000K gates	$I_{DD5}$		40	800	$\mu\text{A}$	$V_I = V_{DD}$ or GND
> 2000K gates	$I_{DD5}$		70	1400	$\mu\text{A}$	$V_I = V_{DD}$ or GND
Off-state output leakage current						
2.5V output	$I_{OZ}$			$\pm 10$	$\mu\text{A}$	$V_O = V_{DD}$ or GND
3.3V output	$I_{OZ}$			$\pm 10$	$\mu\text{A}$	$V_O = V_{DD}$ or GND
Output sink current with pull-up ( $V_O = 2.5\text{V}$ )	$I_R$				$\mu\text{A}$	$V_{PU} = 3.3\text{ V}$ , $R_{PU} = 2\text{k}\Omega$
Output sink short circuit current	$I_{OS}$			-250	$\text{mA}$	$V_O = \text{GND}$
Input leakage current						
Regular	$I_I$		$\pm 10^{-4}$	$\pm 10$	$\mu\text{A}$	$V_I = V_{DD}$ or GND
50 k $\Omega$ pull-up	$I_I$		TBD		$\mu\text{A}$	$V_I = \text{GND}$
5 k $\Omega$ pull-up	$I_I$		TBD		$\text{mA}$	$V_I = \text{GND}$
50 k $\Omega$ pull-down	$I_I$		TBD		$\mu\text{A}$	$V_I = V_{DD}$
Pull-up resistor						
50 k $\Omega$ pull-up	$R_{PU}$		TBD		$\text{k}\Omega$	
5 k $\Omega$ pull-up	$R_{PU}$		TBD		$\text{k}\Omega$	
50 k $\Omega$ pull-down	$R_{PD}$		TBD		$\text{k}\Omega$	
Low-level output current						
2.5V buffers						
3 mA	$I_{OL}$	11.0	8.8	5.2	$\text{mA}$	$V_{OL} = 0.4\text{V}$
6 mA	$I_{OL}$	22.3	17.6	11.5	$\text{mA}$	$V_{OL} = 0.4\text{V}$
9 mA	$I_{OL}$	33.5	26.5	15.8	$\text{mA}$	$V_{OL} = 0.4\text{V}$
12 mA	$I_{OL}$	44.5	35.3	21.2	$\text{mA}$	$V_{OL} = 0.4\text{V}$
18 mA	$I_{OL}$	66.7	52.9	31.7	$\text{mA}$	$V_{OL} = 0.4\text{V}$
24 mA	$I_{OL}$	88.7	70.5	42.3	$\text{mA}$	$V_{OL} = 0.4\text{V}$
3.3V buffers (full-swing)						
3 mA	$I_{OL}$	20.5	14.5	8.3	$\text{mA}$	$V_{OL} = 0.4\text{V}$
6 mA	$I_{OL}$	30.3	21.7	12.5	$\text{mA}$	$V_{OL} = 0.4\text{V}$
9 mA	$I_{OL}$	40.5	29.0	16.7	$\text{mA}$	$V_{OL} = 0.4\text{V}$
12 mA	$I_{OL}$	46.8	36.0	20.8	$\text{mA}$	$V_{OL} = 0.4\text{V}$
Low-level output voltage						
2.5V buffers	$V_{OL}$			0.1	$\text{V}$	$I_{OL} = 0\text{ mA}$
3.3V buffers	$V_{OL}$			0.1	$\text{V}$	$I_{OL} = 0\text{ mA}$
High-level output voltage						
2.5V buffers	$V_{OH}$	$V_{DD} - 0.1$			$\text{V}$	$I_{OH} = 0\text{ mA}$
3.3V buffers	$V_{OH}$	$V_{DD} - 0.1$			$\text{V}$	$I_{OH} = 0\text{ mA}$

## THIRD-PARTY DESIGN CENTERS

### SOUTH CENTRAL/SOUTHEAST

- Koos Technical Services, Inc.  
385 Commerce Way, Suite 101  
Longwood, FL 32750  
  
TEL 407-260-8727  
FAX 407-260-6227
- Integrated Silicon Systems Inc.  
2222 Chapel Hill Nelson Highway  
Durham, NC 27713  
  
TEL 919-361-5814  
FAX 919-361-2019
- Applied Systems, Inc.  
1761 W. Hillsboro Blvd., Suite 328  
Deerfield Beach, FL 33442  
  
TEL 305-428-0534  
FAX 305-428-5906

---

# NEC

## NEC Electronics Inc.

CORPORATE HEADQUARTERS  
2880 Scott Boulevard  
P.O. Box 58062  
Santa Clara, CA 95052  
TEL 408-588-6000

For literature, call toll-free 7 a.m. to 6 p.m. Pacific time: **1-800-366-9782**  
or FAX your request to: **1-800-729-9288**

---

No part of this document may be copied or reproduced in any form or by any means without the prior written consent of NEC Electronics Inc. (NECEL). The information in this document is subject to change without notice. ALL DEVICES SOLD BY NECEL ARE COVERED BY THE PROVISIONS APPEARING IN NECEL TERMS AND CONDITIONS OF SALES ONLY. INCLUDING THE LIMITATION OF LIABILITY, WARRANTY, AND PATENT PROVISIONS. NECEL makes no warranty, express, statutory, implied or by description, regarding information set forth herein or regarding the freedom of the described devices from patent infringement. NECEL assumes no responsibility for any errors that may appear in this document. NECEL makes no commitments to update or to keep current information contained in this document. The devices listed in this document are not suitable for use in applications such as, but not limited to, aircraft control systems, aerospace equipment, submarine cables, nuclear reactor control systems and life support systems. "Standard" quality grade devices are recommended for computers, office equipment, communication equipment, test and measurement equipment, machine tools, industrial robots, audio and visual equipment, and other consumer products. For automotive and transportation equipment, traffic control systems, anti-disaster and anti-crime systems, it is recommended that the customer contact the responsible NECEL salesperson to determine the reliability requirements for any such application and any cost adder. NECEL does not recommend or approve use of any of its products in life support devices or systems or in any application where failure could result in injury or death. If customers wish to use NECEL devices in applications not intended by NECEL, customer must contact the responsible NECEL sales people to determine NECEL's willingness to support a given application.