

16-bit Microcontroller

CMOS

F²MC-16LX MB90925 Series

MB90F927/F927S/V925-101/V925-102

■ DESCRIPTION

MB90925 series is a 16-bit general-purpose high-capacity microcontroller designed for vehicle meter control applications etc.

The instruction set retains the same AT architecture as F²MC-8L and F²MC-16L series, with further refinements including high-level language instructions, expanded addressing mode, enhanced signed multiplication and division computation and bit processing.

In addition, a 32-bit accumulator is built in to enable long word processing.

Note : F²MC is the abbreviation of FUJITSU Flexible Microcontroller.

■ FEATURES

- Clock

Built-in PLL clock frequency multiplication circuit.

Selection of machine clocks (PLL clocks) is allowed among frequency division by 2 on oscillation clock and multiplication of 1 to 4 times of oscillation clock(for 4 MHz oscillation clock, 4 MHz to 16 MHz).

Operation by sub clock(up to 50 kHz : 100 kHz oscillation clock divided by 2).

(Continued)

Be sure to refer to the "Check Sheet" for the latest cautions on development.

"Check Sheet" is seen at the following support page

URL : <http://www.fujitsu.com/global/services/microelectronics/product/micom/support/index.html>

"Check Sheet" lists the minimal requirement items to be checked to prevent problems beforehand in system development.

MB90925 Series

- 16-bit input capture (4 channels)
Detects rising, falling, or both edges.
16-bit capture register × 4
Pin input edge detection latches the 16-bit free-run timer counter value, and generates an interrupt request.
- 16-bit reload timer (2 channels)
16-bit reload timer operation (select toggle output or one-shot output)
Event count function selection provided
- Real Time watch timer (main clock)
Operates directly from oscillator clock.
Interrupt can be generated by second/minute/hour/date counter overflow.
- 16-bit PPG (3 channels)
Output pins (3 channels) , external trigger input pin (1 channel)
Output clock frequencies : f_{CP} , $f_{CP}/2^2$, $f_{CP}/2^4$, $f_{CP}/2^6$
- Delay interrupt
Generates interrupt for task switching.
Interrupts to CPU can be generated/deleted by software setting.
- External interrupts (8 channels)
8-channel independent operation
Interrupt source setting available : “L” to “H” edge/ “H” to “L” edge/ “L” level/ “H” level.
- A/D converter
10-bit or 8-bit resolution × 8 channels (input multiplexed)
Conversion time : 2.6 μ s (at f_{CP} = 16 MHz)
External trigger startup available (P50/INT0/ADTG)
Internal timer startup available (16-bit reload timer 1)
- UART(LIN/SCI) (2 channels)
Equipped with full duplex double buffer
Clock-asynchronous or clock-synchronous serial transfer is available
- SIO (1 channel)
Clock synchronized data transmission.
LSB-first or MSB-first data transfer selection is available.
- CAN interface
Conforms to CAN specifications version 2.0 Part A and B.
Automatic resend in case of error.
Automatic transfer in response to remote frame.
16 prioritized message buffers for data and ID
Multiple message support
Receiving filter has flexible configuration : Full bit compare/full bit mask/two partial bit masks
Supports up to 1 Mbps
CAN WAKEUP function (connects RX internally to INT0)
- LCD controller/driver (32 segment x 4 common)
Segment driver and command driver with direct LCD panel (display) drive capability
- Low voltage/Program looping detect reset
Automatic reset when low voltage is detected
Program looping detection function

(Continued)

(Continued)

- Stepping motor controller (4 channels)
 - High current output for each channel $\times 4$
 - Synchronized 8/10-bit PWM for each channel $\times 2$
- Sound generator
 - 8-bit PWM signal mixed with tone frequency from 8-bit reload counter.
 - PWM frequencies : 62.5 kHz, 31.2 kHz, 15.6 kHz, 7.8 kHz (at $f_{CP} = 16$ MHz)
 - Tone frequencies : 1/2 PWM frequency, divided by (reload frequency +1)
- Input/output ports
 - General-purpose input/output port (CMOS output)
 - 70 ports (dual clock system)
 - 72 ports (single clock system)
- Input level select function for port
 - Automotive/CMOS-Schmitt (initial level is Automotive in single chip mode)
- Flash memory security function
 - Protect the content of Flash memory (Flash memory product only)

MB90925 Series

■ PRODUCT LINEUP

Part number	MB90F927	MB90F927S	MB90V925-101	MB90V925-102
Type	Flash memory product		Evaluation product	
CPU	F ² MC-16LX CPU			
System clock	PLL clock multiplier circuit (× 1, × 2, × 3, × 4, 1/2 when PLL stopped) Minimum instruction execution time 62.5 ns (with 4 MHz oscillation clock × 4)			
Sub clock pin (X0A, X1A)	Yes	No		Yes
ROM	Flash memory 64 Kbytes		External	
RAM	4 Kbytes		13.5 Kbytes	
I/O port	70 ports	72 ports		70 ports
SIO	1 channel			
LCD segment	32			
UART	UART(LIN/SCI) 2 channels			
CAN interface	1 channel			
16-bit input capture	4 channels			
16-bit reload timer	2 channels			
16-bit free-run timer	1 channel			
Real time watch timer	1 channel			
16-bit PPG	3 channels			
External interrupt	8 channels			
8/10-bit A/D converter	8 channels			
LVD/CPU loop reset	Yes		No	
Stepping motor controller	4 channels			
Sound generator	1 channel			
Flash memory security	Yes		No	
Operation voltage	3.7 V to 5.5 V		4.5 V to 5.5 V	
Packages	QFP-100, LQFP-100		PGA-299	

PIN ASSIGNMENTS

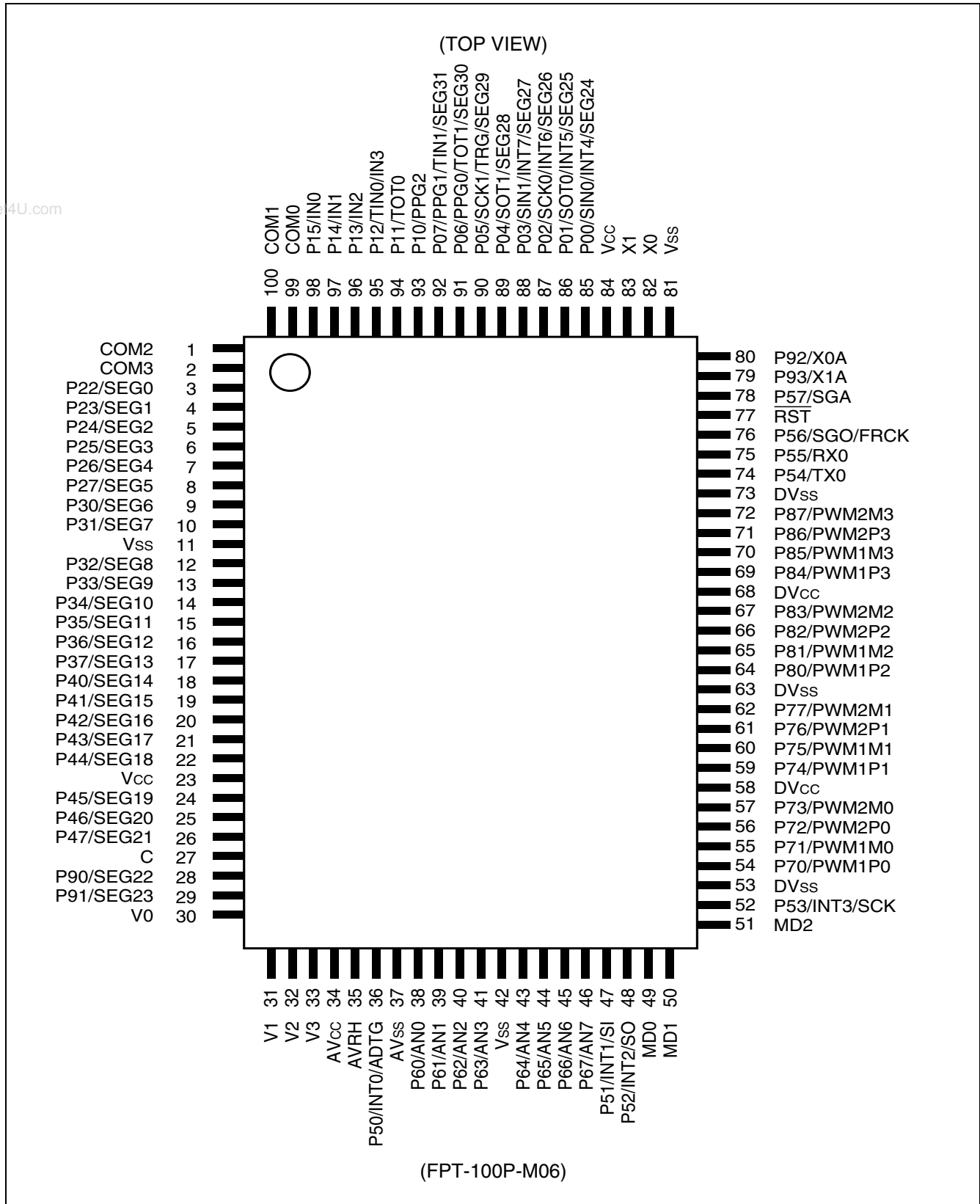

MB90925 Series

(TOP VIEW)

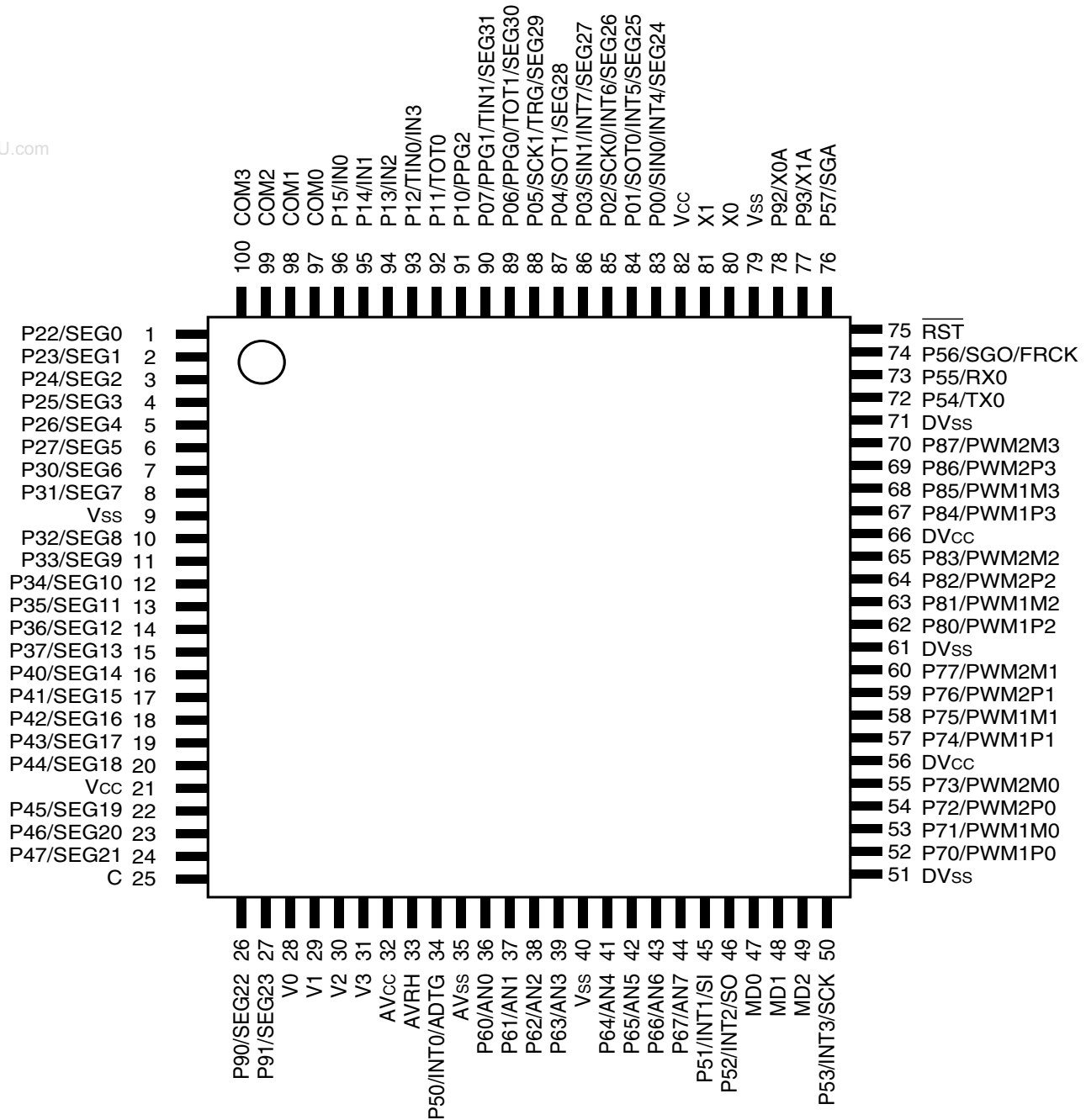

(FPT-100P-M05)

■ PIN DESCRIPTIONS

Pin no.		Pin name	I/O circuit type*3	Function
LQFP*1	QFP*2			
80	82	X0	A	High speed oscillator input pin
81	83	X1		High speed oscillator output pin
78	80	P92	G	General-purpose I/O port
		X0A	A	Low speed oscillator input pin. If no oscillator is connected, apply pull-down processing.
77	79	P93	G	General-purpose I/O port
		X1A	A	Low speed oscillator output pin. If no oscillator is connected, leave open.
75	77	\overline{RST}	B	Reset input pin
83	85	P00	J	General-purpose input/output port
		SIN0		UART ch.0 serial data input pin
		INT4		INT4 external interrupt input pin
		SEG24		LCD controller/driver segment output
84	86	P01	E	General-purpose input/output port
		SOT0		UART ch.0 serial data output pin
		INT5		INT5 external interrupt input pin
		SEG25		LCD controller/driver segment output
85	87	P02	E	General-purpose input/output port
		SCK0		UART ch.0 serial clock input/output pin
		INT6		INT6 external interrupt input pin
		SEG26		LCD controller/driver segment output
86	88	P03	J	General-purpose input/output port
		SIN1		UART ch.1 serial data input pin
		INT7		INT7 external interrupt input pin
		SEG27		LCD controller/driver segment output
87	89	P04	E	General-purpose input/output port
		SOT1		UART ch.1 serial data output pin
		SEG28		LCD controller/driver segment output
88	90	P05	E	General-purpose input/output port
		SCK1		UART ch.1 serial clock input/output pin
		TRG		16-bit PPG ch.0 to ch.2 external trigger input pin
		SEG29		LCD controller/driver segment output

(Continued)

MB90925 Series

Pin no.		Pin name	I/O circuit type*3	Function
LQFP*1	QFP*2			
89	91	P06	E	General-purpose input/output port
		PPG0		16-bit PPG ch.0 output pin
		TOT1		16-bit reload timer ch.1 TOT output pin
		SEG30		LCD controller/driver segment output
90	92	P07	E	General-purpose input/output port
		PPG1		16-bit PPG ch.1 output pin
		TIN1		16-bit reload timer ch.1 TIN output pin
		SEG31		LCD controller/driver segment output
91	93	P10	G	General-purpose input/output port
		PPG2		16-bit PPG ch.2 output pin
92	94	P11	G	General-purpose input/output port
		TOT0		16-bit reload timer ch.0 TOT output pin
93	95	P12	G	General-purpose input/output port
		TIN0		16-bit reload timer ch.0 TIN output pin
		IN3		Input capture ch.3 trigger input pin
94 to 96	96 to 98	P13 to P15	G	General-purpose input/output port
		IN2 to IN0		Input capture ch.2 to ch.0 trigger input pins
97 to 100	99, 100, 1, 2	COM0 to COM3	I	LCD controller/driver common output pins
1 to 6	3 to 8	P22 to P27	E	General-purpose input/output ports
		SEG0 to SEG5		LCD controller/driver segment output pins
7, 8, 10 to 15	9, 10, 12 to 17	P30 to P37	E	General-purpose input/output port
		SEG6 to SEG13		LCD controller/driver segment output pins
16 to 20, 22 to 24	18 to 22, 24 to 26	P40 to P47	E	General-purpose input/output port
		SEG14 to SEG21		LCD controller/driver segment output pins
26, 27	28, 29	P90, P91	E	General-purpose input/output port
		SEG22, SEG23		LCD controller/driver segment output pins
34	36	P50	G	General-purpose input/output port
		INT0		INT0 external interrupt input pin
		ADTG		A/D converter external trigger input pin

(Continued)

MB90925 Series

Pin no.		Pin name	I/O circuit type*3	Function
LQFP*1	QFP*2			
36 to 39, 41 to 44	38 to 41, 43 to 46	P60 to P67	F	General-purpose input/output port
		AN0 to AN7		A/D converter input pins
45	47	P51	K	General-purpose input/output port
		INT1		INT1 external interrupt input pin
		SI		SIO data input pin
46	48	P52	G	General-purpose input/output port
		INT2		INT2 external interrupt input pin
		SO		SIO data output pin
50	52	P53	G	General-purpose input/output port
		INT3		INT3 external interrupt input pin
		SCK		SIO clock input/output pin
52 to 55	54 to 57	P70 to P73	H	General-purpose input/output port
		PWM1P0, PWM1M0, PWM2P0, PWM2M0		Stepping motor controller ch.0 output pins
57 to 60	59 to 62	P74 to P77	H	General-purpose input/output port
		PWM1P1, PWM1M1, PWM2P1, PWM2M1		Stepping motor controller ch.1 output pins
62 to 65	64 to 67	P80 to P83	H	General-purpose input/output port
		PWM1P2, PWM1M2, PWM2P2, PWM2M2		Stepping motor controller ch.2 output pins
67 to 70	69 to 72	P84 to P87	H	General-purpose input/output port
		PWM1P3, PWM1M3, PWM2P3, PWM2M3		Stepping motor controller ch.3 output pins
72	74	P54	G	General-purpose input/output port
		TX0		CAN interface 0 TX output pin
73	75	P55	G	General-purpose output port
		RX0		CAN interface 0 RX input pin

(Continued)

MB90925 Series

(Continued)

Pin no.		Pin name	I/O circuit type*3	Function
LQFP*1	QFP*2			
74	76	P56	G	General-purpose input/output port
		SGO		Sound generator SGO output pin
		FRCK		Free-run timer clock input pin
76	78	P57	G	General-purpose input/output port
		SGA		Sound generator SGA output pin
28 to 31	30 to 33	V0 to V3	—	LCD controller /driver reference power supply pins
56, 66	58, 68	DV _{CC}	—	Power supply input pins dedicated for high current output buffer (pin numbers 54 to 57, 59 to 62, 64 to 67, 69 to 72) .
51, 61, 71	53, 63, 73	DV _{SS}	—	Power supply GND pins dedicated for high current output buffer (pin numbers 54 to 57, 59 to 62, 64 to 67, 69 to 72) .
32	34	AV _{CC}	—	A/D converter dedicated power supply input pin
35	37	AV _{SS}	—	A/D converter dedicated power supply GND pin
33	35	AVRH	—	A/D converter Vref + input pin
47, 48	49, 50	MD0, MD1	C	Test mode input pins. Connect to V _{CC} .
49	51	MD2	C/D*4	Test mode input pin. Connect to V _{SS} .
25	27	C	—	External capacitor pin. Connect an 0.1 μF capacitor between this pin and V _{SS} .
21, 82	23, 84	V _{CC}	—	Power supply input pins
9, 40, 79	11, 42, 81	V _{SS}	—	Power supply GND pins

*1: FPT-100P-M05

*2: FPT-100P-M06

*3: For the I/O circuit type, refer to “■ I/O CIRCUIT TYPE”

*4: Type C in MB90F927 and MB90F927S, type D in MB90V925-101 and MB90V925-102.

I/O CIRCUIT TYPE

Type	Circuit	Remarks
A		<ul style="list-style-type: none"> High-speed oscillation pin Oscillation feedback resistance : approx. 1 MΩ (X0, X1 : MAIN) Low-speed oscillation pin Oscillation feedback resistance : approx. 10 MΩ (X0A, X1A : SUB)
B		Input dedicated pin (with pull-up resistance) <ul style="list-style-type: none"> Pull-up resistance attached : approx. 50 kΩ Hysteresis input ($V_{IH}/V_{IL} = 0.8V_{CC}/0.2V_{CC}$)
C		Input dedicated pin Hysteresis input ($V_{IH}/V_{IL} = 0.8V_{CC}/0.2V_{CC}$)
D		Input dedicated pin (with pull-down resistance) <ul style="list-style-type: none"> Pull-down resistance attached : approx. 50 kΩ Hysteresis input ($V_{IH}/V_{IL} = 0.8V_{CC}/0.2V_{CC}$)
E		LCDC output common general-purpose port <ul style="list-style-type: none"> CMOS output ($I_{OH}/I_{OL} = \pm 4 \text{ mA}$) Hysteresis input ($V_{IH}/V_{IL} = 0.8V_{CC}/0.2V_{CC}$) Automotive input ($V_{IH}/V_{IL} = 0.8V_{CC}/0.5V_{CC}$)

(Continued)

MB90925 Series

Type	Circuit	Remarks
F	<p> P-ch N-ch Pout Nout Analog input Hysteresis input Standby control signal or Analog input enable signal Automotive input Standby control signal or Analog input enable signal </p>	A/D converter input common general-purpose port <ul style="list-style-type: none"> • CMOS output ($I_{OH}/I_{OL} = \pm 4 \text{ mA}$) • Hysteresis input ($V_{IH}/V_{IL} = 0.8V_{CC}/0.2V_{CC}$) • Automotive input ($V_{IH}/V_{IL} = 0.8V_{CC}/0.5V_{CC}$)
G	<p> P-ch N-ch Pout Nout Hysteresis input Standby control signal Automotive input Standby control signal </p>	General-purpose port <ul style="list-style-type: none"> • CMOS output ($I_{OH}/I_{OL} = \pm 4 \text{ mA}$) • Hysteresis input ($V_{IH}/V_{IL} = 0.8V_{CC}/0.2V_{CC}$) • Automotive input ($V_{IH}/V_{IL} = 0.8V_{CC}/0.5V_{CC}$)
H	<p> P-ch N-ch Pout high current output Nout high current output Hysteresis input Standby control signal Automotive input Standby control signal </p>	High current output common general-purpose port <ul style="list-style-type: none"> • CMOS output ($I_{OH}/I_{OL} = \pm 30 \text{ mA}$) • Hysteresis input ($V_{IH}/V_{IL} = 0.8V_{CC}/0.2V_{CC}$) • Automotive input ($V_{IH}/V_{IL} = 0.8V_{CC}/0.5V_{CC}$)

(Continued)

(Continued)

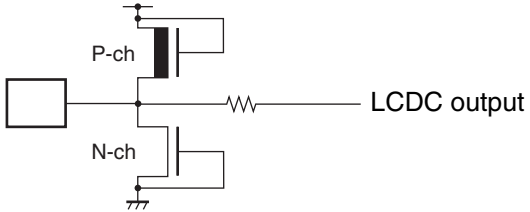
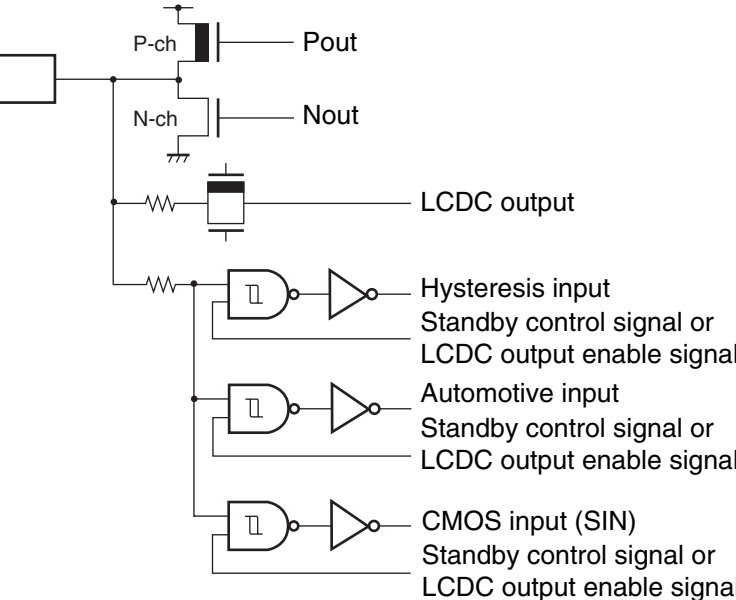
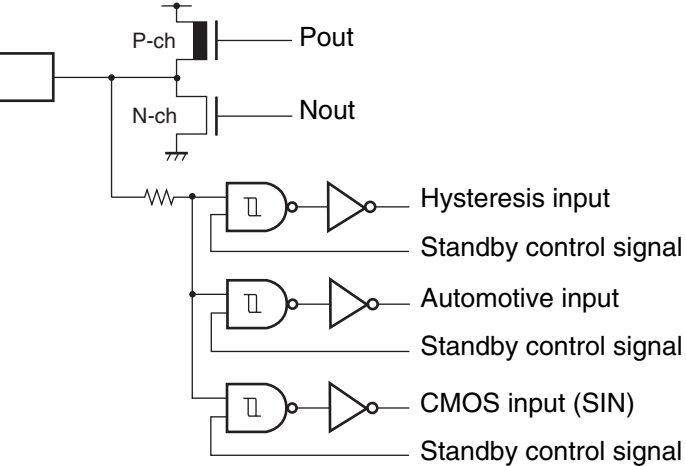
Type	Circuit	Remarks
I		LCDC output pin (COM pin)
J		LCDC output common general-purpose port (serial input) <ul style="list-style-type: none"> • CMOS output ($I_{OH}/I_{OL} = \pm 4 \text{ mA}$) • Hysteresis input ($V_{IH}/V_{IL} = 0.8V_{CC}/0.2V_{CC}$) • CMOS input (SIN) ($V_{IH}/V_{IL} = 0.7V_{CC}/0.3V_{CC}$) • Automotive input ($V_{IH}/V_{IL} = 0.8V_{CC}/0.5V_{CC}$)
K		General-purpose port (serial input) <ul style="list-style-type: none"> • CMOS output ($I_{OH}/I_{OL} = \pm 4 \text{ mA}$) • Hysteresis input ($V_{IH}/V_{IL} = 0.8V_{CC}/0.2V_{CC}$) • CMOS input (SIN) ($V_{IH}/V_{IL} = 0.7V_{CC}/0.3V_{CC}$) • Automotive input ($V_{IH}/V_{IL} = 0.8V_{CC}/0.5V_{CC}$)

■ HANDLING DEVICES

• Strictly observe maximum rated voltages (preventing latch-up)

In CMOS IC devices, a condition known as latch-up may occur if voltages higher than V_{CC} or lower than V_{SS} are applied to input or output pins other than medium-or high-voltage pins, or if the voltage applied between V_{CC} and V_{SS} exceeds the rated voltage level. In a latch-up condition, the power supply current can increase dramatically and may destroy semiconductor elements. In using semiconductor devices, always take sufficient care to avoid exceeding maximum ratings.

Also care must be taken when the analog system power supply is switched on or off to ensure that the analog power supply (AV_{CC} , AV_{RH}), the analog input voltages and the power supply voltage for the high current output buffer pins (DV_{CC}) do not exceed the digital power supply voltage (V_{CC}).

Once the digital power supply voltage (V_{CC}) has been disconnected, the analog power supply (AV_{CC} , AV_{RH}) and the power supply voltage for the high current output buffer pins (DV_{CC}) may be turned on in any sequence.

• Stable supply voltage

Even within the warranted operating range of V_{CC} power supply voltage, rapid fluctuations in the power supply voltage can cause malfunctions. The recommended stability for ripple fluctuations (P-P value) at commercial frequencies (50 Hz/60 Hz) should be within 10% of the standard V_{CC} value, and voltage fluctuations that occur during switching of power supplies etc. should be limited to transient fluctuation rates of 0.1 V/ms or less.

• Notes on energization Power-on procedures

In order to prevent the built-in step-down circuits from malfunctioning, the voltage rising time (0.2 V to 2.7 V) during power-on should be attained within 50 μ s.

• Treatment of unused pins

If unused input pins are left open, they may cause malfunctions or latch-up which may lead to permanent damage to the semiconductor. Unused input pins should therefore be pulled up or pulled down through a resistor of at least 2 k Ω .

Any unused input/output pins should be left open in output status, or if found set to input status, they should be treated in the same way as input pins.

• Treatment of A/D converter power supply pins

Even if the A/D converter is not used, pins should be connected so that $AV_{CC} = V_{CC}$, and $AV_{SS} = AV_{RH} = V_{SS}$.

• Notes on Using an external clock

Even when an external clock is used, an oscillation stabilization wait time is required following power-on reset or release from sub clock mode or stop mode. Also, when an external clock is used, it should drive only the X0 pin and the X1 pin should be left open, as shown below.

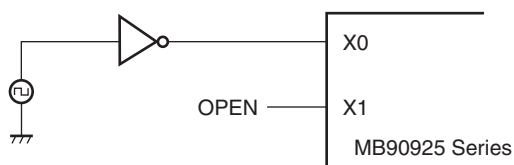

Sample external clock connection

- **Power supply pins**

Devices are designed to prevent problems such as latch-up when multiple V_{CC} and V_{SS} pins are used, by providing internal connections between pins having the same potential. However, in order to reduce unwanted radiation, to prevent abnormal operation of strobe signals due to rise in ground level, and to maintain total output current ratings, all V_{CC} and V_{SS} pins should always be connected externally to power supplies and ground respectively.

As shown in the figure below, all V_{CC} pins must have the same potential and all V_{SS} pins must be at the same potential. If there are multiple V_{CC} or V_{SS} systems, the device will not operate properly even within the warranted operating range.

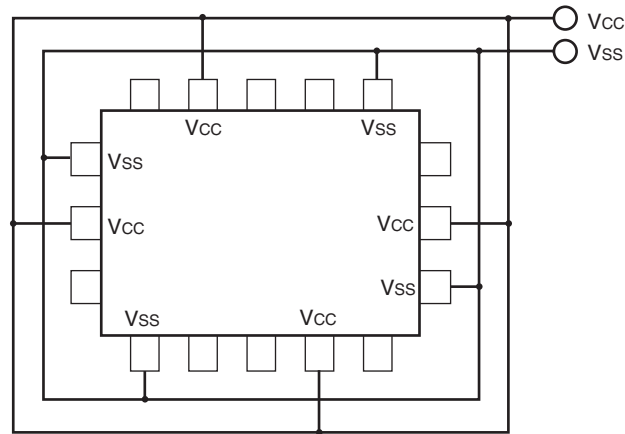

Power supply input pins (V_{CC}/V_{SS})

In addition, care must be given to connecting the V_{CC} and V_{SS} pins of this device to the current supply source with as low impedance as possible. It is recommended that a 1.0 μF bypass capacitor be connected between the V_{CC} and V_{SS} pins as close to the pins as possible.

- **Turning-on sequence of power supply to A/D converter and analog inputs**

The A/D converter power supply (AV_{CC} , AV_{RH}) and analog inputs ($AN0$ to $AN7$) must be applied after the digital power supply (V_{CC}) is switched on. When power is shut off, the A/D converter power supply and analog inputs must be cut off before the digital power supply is switched off (V_{CC}). In both power-on and power-off, care should be taken that AV_{RH} does not exceed AV_{CC} . Even when pins which double as analog input pins are used as input ports, be sure that the input voltage does not exceed AV_{CC} .

- **Handling the power supply for high-current output buffer pins (DV_{CC} , DV_{SS})**

Always apply power supply to high-current output buffer pins (DV_{CC} , DV_{SS}) after the digital power supply (V_{CC}) is turned on. Also when switching the power off, always shut off the power supply to the high-current output buffer pins (DV_{CC} , DV_{SS}) before switching off the digital power supply (V_{CC}). There is no problem if the high-current output buffer pins and digital power supplies are turned off and on at the same time.

Even when the high-current output buffer pins are used as general-purpose ports, the power supply for high current output buffer pins (DV_{CC} , DV_{SS}) should be applied to these pins.

- **Pull-up/pull-down resistor**

MB90925 series does not support internal pull-up/pull-down resistor. If necessary, use external components.

MB90925 Series

- **Precautions for when not using a sub clock signal**

If the X0A and X1A pins are not connected to an oscillator, apply pull-down treatment to the X0A pin and leave the X1A pin open.

- **Notes on operation when external clock is stopped**

When there is no external oscillator or external clock input is stopped, performance of the operation by MB90925 series the internal oscillation circuit cannot be guaranteed.

■ BLOCK DIAGRAM

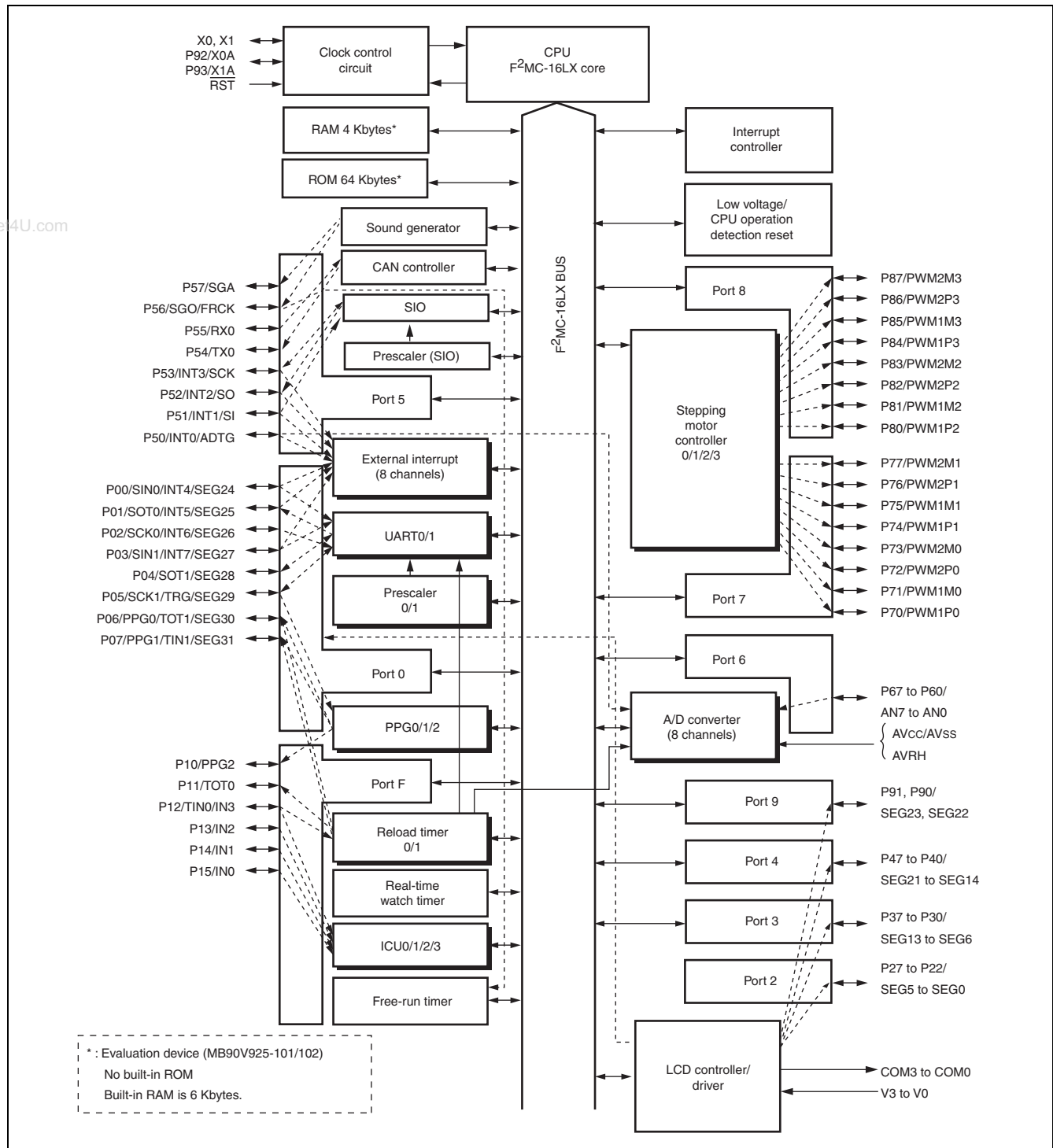

MB90925 Series

MEMORY MAP

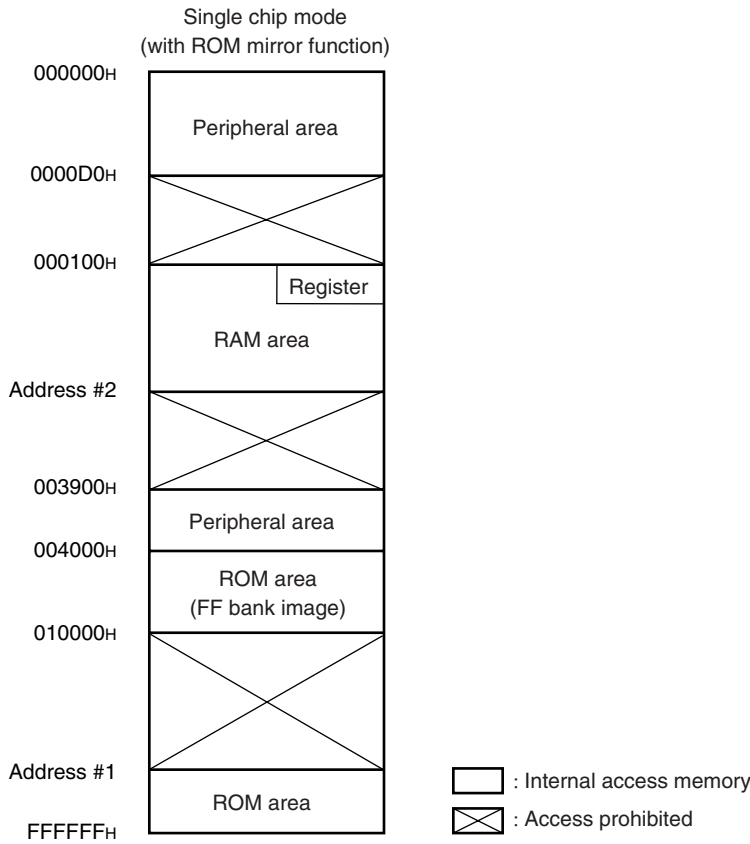

Part number	Address #1	Address #2
MB90F927/MB90F927S	FF0000H	001100H
MB90V925-101/MB90V925-102	F80000H	003700H

Note : To select models without the ROM mirror function, refer to the “ROM Mirror Function Selection Module” in Hardware Manual. The image of the ROM data in the FF bank appears at the top of the 00 bank, in order to enable efficient use of small C compiler models. The lower 16-bit address for the FF bank will be assigned to the same address, so that tables in ROM can be referenced without declaring a “far” indication with the pointer. For example when accessing the address 00C000H, the actual access is to address FFC000H in ROM. Here the FF bank ROM area exceeds 48 Kbytes, so that it is not possible to see the entire area in the 00 bank image. Therefore because the ROM data from FF4000H to FFFFFFFH will appear in the image from 004000H to 00FFFFH, it is recommended that the ROM data table be stored in the area from FF4000H to FFFFFFFH.

■ I/O MAP

- Other than CAN Interface

Address	Register name	Symbol	Read/write	Resource name	Initial value
000000 _H	Port 0 data register	PDR0	R/W	Port 0	XXXXXXXX _B
000001 _H	Port 1 data register	PDR1	R/W	Port 1	- - XXXXXX _B
000002 _H	Port 2 data register	PDR2	R/W	Port 2	XXXXXX - - _B
000003 _H	Port 3 data register	PDR3	R/W	Port 3	XXXXXXXX _B
000004 _H	Port 4 data register	PDR4	R/W	Port 4	XXXXXXXX _B
000005 _H	Port 5 data register	PDR5	R/W	Port 5	XXXXXXXX _B
000006 _H	Port 6 data register	PDR6	R/W	Port 6	XXXXXXXX _B
000007 _H	Port 7 data register	PDR7	R/W	Port 7	XXXXXXXX _B
000008 _H	Port 8 data register	PDR8	R/W	Port 8	XXXXXXXX _B
000009 _H	Port 9 data register	PDR9	R/W	Port 9	- - - -XXXX _B
00000A _H to 00000F _H	(Disabled)				
000010 _H	Port 0 direction register	DDR0	R/W	Port 0	0 0 0 0 0 0 0 0 _B
000011 _H	Port 1 direction register	DDR1	R/W	Port 1	- - 0 0 0 0 0 0 _B
000012 _H	Port 2 direction register	DDR2	R/W	Port 2	0 0 0 0 0 0 - - _B *
000013 _H	Port 3 direction register	DDR3	R/W	Port 3	0 0 0 0 0 0 0 0 _B *
000014 _H	Port 4 direction register	DDR4	R/W	Port 4	0 0 0 0 0 0 0 0 _B
000015 _H	Port 5 direction register	DDR5	R/W	Port 5	0 0 0 0 0 0 0 0 _B
000016 _H	Port 6 direction register	DDR6	R/W	Port 6	0 0 0 0 0 0 0 0 _B
000017 _H	Port 7 direction register	DDR7	R/W	Port 7	0 0 0 0 0 0 0 0 _B
000018 _H	Port 8 direction register	DDR8	R/W	Port 8	0 0 0 0 0 0 0 0 _B
000019 _H	Port 9 direction register	DDR9	R/W	Port 9	- - - - 0 0 0 0 _B
00001A _H	Analog input enable	ADER	R/W	Port 6, A/D	1 1 1 1 1 1 1 1 _B
00001B _H to 00001F _H	(Disabled)				
000020 _H	A/D control status register lower	ADCS0	R/W	8/10-bit A/D converter	0 0 0 - - - 0 _B
000021 _H	A/D control status register higher	ADCS1	R/W		0 0 0 0 0 0 0 - _B
000022 _H	A/D data register lower	ADCR0	R		0 0 0 0 0 0 0 0 _B
000023 _H	A/D data register higher	ADCR1	R		- - - - - 0 0 _B
000024 _H	Compare clear register	CPCLR	R/W	16-bit free-run timer	XXXXXXXX _B
000025 _H			R/W		XXXXXXXX _B
000026 _H	Timer data register	TCDT	R/W		0 0 0 0 0 0 0 0 _B
000027 _H			R/W		0 0 0 0 0 0 0 0 _B
000028 _H	Timer control status register lower	TCCSL	R/W		0 0 0 0 0 0 0 0 _B
000029 _H	Timer control status register higher	TCCSH	R/W		0 1 - 0 0 0 0 0 _B

(Continued)

MB90925 Series

Address	Register name	Symbol	Read/write	Resource name	Initial value
00002AH	PPG0 control status register lower	PCNTL0	R/W	16-bit PPG0	0 0 0 0 0 0 0 0 _B
00002BH	PPG0 control status register higher	PCNTH0	R/W		0 0 0 0 0 0 0 1 _B
00002CH	PPG1 control status register lower	PCNTL1	R/W	16-bit PPG1	0 0 0 0 0 0 0 0 _B
00002DH	PPG1 control status register higher	PCNTH1	R/W		0 0 0 0 0 0 0 1 _B
00002EH	PPG2 control status register lower	PCNTL2	R/W	16-bit PPG2	0 0 0 0 0 0 0 0 _B
00002FH	PPG2 control status register higher	PCNTH2	R/W		0 0 0 0 0 0 0 1 _B
000030H	External interrupt enable	ENIR	R/W	External interrupt	0 0 0 0 0 0 0 0 _B
000031H	External interrupt request	EIRR	R/W		0 0 0 0 0 0 0 0 _B
000032H	External interrupt level lower	ELVRL	R/W		0 0 0 0 0 0 0 0 _B
000033H	External interrupt level higher	ELVRH	R/W		0 0 0 0 0 0 0 0 _B
000034H	Serial mode register 0	SMR0	R/W	UART(LIN/SCI) 0	0 0 0 0 0 0 0 0 _B
000035H	Serial control register 0	SCR0	R/W		0 0 0 0 0 0 0 0 _B
000036H	Reception/transmission data register 0	RDR0/ TDR0	R/W		0 0 0 0 0 0 0 0 _B
000037H	Serial status register 0	SSR0	R/W		0 0 0 0 1 0 0 0 _B
000038H	Extended communication control register 0	ECCR0	R/W		0 0 0 0 0 0 X X _B
000039H	Extended status control register	ESCR0	R/W		0 0 0 0 0 1 0 0 _B
00003AH	Baud rate generator register 00	BGR00	R/W		0 0 0 0 0 0 0 0 _B
00003BH	Baud rate generator register 01	BGR01	R/W		0 0 0 0 0 0 0 0 _B
00003CH, 00003DH	(Disabled)				
00003EH	CAN wake-up control register	CWUCR	R/W	CAN	- - - - - 0 _B
00003FH	(Disabled)				
000040H to 00004FH	Area reserved for CAN interface 0				
000050H	Timer control status register 0 lower	TMCSR0L	R/W	16-bit reload timer 0	0 0 0 0 0 0 0 0 _B
000051H	Timer control status register 0 higher	TMCSR0H	R/W		- - 1 0 0 0 0 0 _B
000052H 000053H	Timer register 0/reload register 0	TMR0/ TMRLR0	R/W		XXXXXXXX _B XXXXXXXX _B
000054H	Timer control status register 1 lower	TMCSR1L	R/W	16-bit reload timer 1	0 0 0 0 0 0 0 0 _B
000055H	Timer control status register 1 higher	TMCSR1H	R/W		- - 1 0 0 0 0 0 _B
000056H 000057H	Timer register 1/reload register 1	TMR1/ TMRLR1	R/W		XXXXXXXX _B XXXXXXXX _B

(Continued)

MB90925 Series

Address	Register name	Symbol	Read/write	Resource name	Initial value
000058 _H	LCD output control register 1	LOCR1	R/W	LCD	1 1 1 1 1 1 1 1 _B
000059 _H	LCD output control register 2	LOCR2	R/W		0 0 0 0 0 0 0 0 _B
00005A _H	Sound control register lower	SGCRL	R/W	Sound generator	0 0 0 0 0 0 0 0 _B
00005B _H	Sound control register higher	SGCRH	R/W		0 - - - - 1 0 0 _B
00005C _H	Frequency data register	SGFR	R/W		XXXXXXXX _B
00005D _H	Amplitude data register	SGAR	R/W		0 0 0 0 0 0 0 0 _B
00005E _H	Decrement grade register	SGDR	R/W		XXXXXXXX _B
00005F _H	Tone count register	SGTR	R/W	XXXXXXXX _B	
000060 _H	Input capture register 0	IPCP0	R	Input capture 0/1	XXXXXXXX _B
000061 _H					XXXXXXXX _B
000062 _H	Input capture register 1	IPCP1	R		XXXXXXXX _B
000063 _H					XXXXXXXX _B
000064 _H	Input capture register 2	IPCP2	R	Input capture 2/3	XXXXXXXX _B
000065 _H					XXXXXXXX _B
000066 _H	Input capture register 3	IPCP3	R		XXXXXXXX _B
000067 _H					XXXXXXXX _B
000068 _H	Input capture control status 0/1	ICS01	R/W	Input capture 0/1	0 0 0 0 0 0 0 0 _B
000069 _H	Input capture edge register 0/1	ICE01	R/W	Input capture 0/1	XXX0X0XX _B
00006A _H	Input capture control status 2/3	ICS23	R/W	Input capture 2/3	0 0 0 0 0 0 0 0 _B
00006B _H	Input capture edge register 2/3	ICE23	R/W	Input capture 2/3	XXXXXXXX _B
00006C _H	LCD control register lower	LCRL	R/W	LCD controller/ driver	0 0 0 1 0 0 0 0 _B
00006D _H	LCD control register higher	LCRH	R/W		0 0 0 0 0 0 0 0 _B
00006E _H	Low voltage/CPU operation detection reset control register	LVRC	R/W	Low voltage/CPU operation detection reset	0 0 1 1 1 0 0 0 _B
00006F _H	ROM mirror	ROMM	W	ROM mirror	XXXXXXXX _{1B}
000070 _H to 00007F _H	(Disabled)				
000080 _H	PWM control register 0	PWC0	R/W	Stepping motor controller 0	0 0 0 0 0 - - 0 _B
000081 _H	(Disabled)				
000082 _H	PWM control register 1	PWC1	R/W	Stepping motor controller 1	0 0 0 0 0 - - 0 _B
000083 _H	(Disabled)				
000084 _H	PWM control register 2	PWC2	R/W	Stepping motor controller 2	0 0 0 0 0 - - 0 _B
000085 _H	(Disabled)				
000086 _H	PWM control register 3	PWC3	R/W	Stepping motor controller 3	0 0 0 0 0 - - 0 _B

(Continued)

MB90925 Series

Address	Register name	Symbol	Read/write	Resource name	Initial value
000087 _H to 000089 _H	(Disabled)				
00008A _H	A/D setting register 0	ADSR0	R/W	A/D	0 0 0 0 0 0 0 0 _B
00008B _H	A/D setting register 1	ADSR1	R/W		0 0 0 0 0 0 0 0 _B
00008C _H	Port input level select 0	PIL0	R/W	Port Input Level Select	0 0 0 0 0 0 0 0 _B
00008D _H	Port input level select 1	PIL1	R/W		- - - 0 0 0 0 0 _B
00008E _H to 00009D _H	(Disabled)				
00009E _H	ROM correction control register	PACSR	R/W	Address match detection function	- - - - - 0 - 0 _B
00009F _H	Delay interrupt/release	DIRR	R/W	Delay interrupt	- - - - - 0 _B
0000A0 _H	Power saving mode	LPMCR	R/W	Power saving control circuit	0 0 0 1 1 0 0 0 _B
0000A1 _H	Clock select	CKSCR	R/W		1 1 1 1 1 1 0 0 _B
0000A2 _H to 0000A7 _H	(Disabled)				
0000A8 _H	Watchdog control	WDTC	R/W	Watchdog timer	XXXXX 1 1 1 _B
0000A9 _H	Time-base timer control register	TBTC	R/W	Time-base timer	1 - - 0 0 1 0 0 _B
0000AA _H	Watch timer control register	WTC	R/W	Watch timer (sub clock)	1 X 0 0 0 0 0 0 _B
0000AB _H to 0000AD _H	(Disabled)				
0000AE _H	Flash control register	FMCS	R/W	Flash memory interface	0 0 0 X 0 XX 0 _B
0000AF _H	(Disabled)				
0000B0 _H	Interrupt control register 00	ICR00	R/W	Interrupt controller	0 0 0 0 0 1 1 1 _B
0000B1 _H	Interrupt control register 01	ICR01	R/W		0 0 0 0 0 1 1 1 _B
0000B2 _H	Interrupt control register 02	ICR02	R/W		0 0 0 0 0 1 1 1 _B
0000B3 _H	Interrupt control register 03	ICR03	R/W		0 0 0 0 0 1 1 1 _B
0000B4 _H	Interrupt control register 04	ICR04	R/W		0 0 0 0 0 1 1 1 _B
0000B5 _H	Interrupt control register 05	ICR05	R/W	Interrupt controller	0 0 0 0 0 1 1 1 _B
0000B6 _H	Interrupt control register 06	ICR06	R/W		0 0 0 0 0 1 1 1 _B
0000B7 _H	Interrupt control register 07	ICR07	R/W		0 0 0 0 0 1 1 1 _B
0000B8 _H	Interrupt control register 08	ICR08	R/W		0 0 0 0 0 1 1 1 _B
0000B9 _H	Interrupt control register 09	ICR09	R/W		0 0 0 0 0 1 1 1 _B
0000BA _H	Interrupt control register 10	ICR10	R/W		0 0 0 0 0 1 1 1 _B
0000BB _H	Interrupt control register 11	ICR11	R/W		0 0 0 0 0 1 1 1 _B
0000BC _H	Interrupt control register 12	ICR12	R/W		0 0 0 0 0 1 1 1 _B

(Continued)

MB90925 Series

Address	Register name	Symbol	Read/write	Resource name	Initial value	
0000BD _H	Interrupt control register 13	ICR13	R/W	Interrupt controller	0 0 0 0 0 1 1 1 _B	
0000BE _H	Interrupt control register 14	ICR14	R/W		0 0 0 0 0 1 1 1 _B	
0000BF _H	Interrupt control register 15	ICR15	R/W		0 0 0 0 0 1 1 1 _B	
0000C0 _H	Serial mode control register (lower)	SMCSL	R/W	SIO	- - - - 0 0 0 0 _B	
0000C1 _H	Serial mode control register (higher)	SMCSH	R/W		0 0 0 0 0 0 1 0 _B	
0000C2 _H	Serial data register	SDR	R/W		XXXXXXXX _B	
0000C3 _H	Communication prescaler control register	SDCR	R/W	Communication prescaler (SIO)	0 - - - 0 0 0 0 _B	
0000C4 _H	Serial mode register 1	SMR1	R/W	UART(LIN/SCI) 1	0 0 0 0 0 0 0 0 _B	
0000C5 _H	Serial control register 1	SCR1	R/W		0 0 0 0 0 0 0 0 _B	
0000C6 _H	Reception/transmission data register 1	RDR1/ TDR1	R/W		0 0 0 0 0 0 0 0 _B	
0000C7 _H	Serial status register 1	SSR1	R/W		0 0 0 0 1 0 0 0 _B	
0000C8 _H	Extended communication control register 1	ECCR1	R/W		0 0 0 0 0 0 XX _B	
0000C9 _H	Extended status control register 1	ESCR1	R/W		0 0 0 0 0 1 0 0 _B	
0000CA _H	Baud rate generator register 10	BGR10	R/W		0 0 0 0 0 0 0 0 _B	
0000CB _H	Baud rate generator register 11	BGR11	R/W		0 0 0 0 0 0 0 0 _B	
0000CC _H	Watch timer control register lower	WTCRL	R/W		Real-time watch timer	0 0 0 - - 0 0 0 _B
0000CD _H	Watch timer control register middle	WTCRM	R/W			0 0 0 0 0 0 0 0 _B
0000CE _H	Watch timer control register higher	WTCRH	R/W			- - - - 0 0 0 0 _B
0000CF _H	Sub clock control register	SCCR	W	Sub clock	- - - - 0 0 0 0 _B	
0000D0 _H to 0000FF _H	(Disabled)					
001FF0 _H	ROM correction address 0	PADR0	R/W	Address match detection function	XXXXXXXX _B	
001FF1 _H	ROM correction address 1	PADR0	R/W		XXXXXXXX _B	
001FF2 _H	ROM correction address 2	PADR0	R/W		XXXXXXXX _B	
001FF3 _H	ROM correction address 3	PADR1	R/W	Address match detection function	XXXXXXXX _B	
001FF4 _H	ROM correction address 4	PADR1	R/W		XXXXXXXX _B	
001FF5 _H	ROM correction address 5	PADR1	R/W		XXXXXXXX _B	
003900 _H to 00391F _H	(Disabled)					
003920 _H	PPG0 down counter register	PDCR0	R	16-bit PPG 0	1 1 1 1 1 1 1 1 _B	
003921 _H					1 1 1 1 1 1 1 1 _B	
003922 _H	PPG0 cycle setting register	PCSR0	W		XXXXXXXX _B	
003923 _H					XXXXXXXX _B	
003924 _H	PPG0 duty setting register	PDUT0	W		XXXXXXXX _B	
003925 _H					XXXXXXXX _B	

(Continued)

MB90925 Series

Address	Register name	Symbol	Read/write	Resource name	Initial value
003926 _H , 003927 _H	(Disabled)				
003928 _H	PPG1 down counter register	PDCR1	R	16-bit PPG 1	1 1 1 1 1 1 1 1 _B
003929 _H					1 1 1 1 1 1 1 1 _B
00392A _H	PPG1 cycle setting register	PCSR1	W		XXXXXXXX _B
00392B _H					XXXXXXXX _B
00392C _H	PPG1 duty setting register	PDUT1	W		XXXXXXXX _B
00392D _H					XXXXXXXX _B
00392E _H , 00392F _H	(Disabled)				
003930 _H	PPG2 down counter register	PDCR2	R	16-bit PPG 2	1 1 1 1 1 1 1 1 _B
003931 _H					1 1 1 1 1 1 1 1 _B
003932 _H	PPG2 cycle setting register	PCSR2	W		XXXXXXXX _B
003933 _H					XXXXXXXX _B
003934 _H	PPG2 duty setting register	PDUT2	W		XXXXXXXX _B
003935 _H					XXXXXXXX _B
003936 _H to 003957 _H	(Disabled)				
003958 _H	Sub second data register	WTBR	R/W	Real time watch timer	XXXXXXXX _B
003959 _H					XXXXXXXX _B
00395A _H					- - - XXXXX _B
00395B _H	Second data register	WTSR	R/W		- - 0 0 0 0 0 _B
00395C _H	Minute data register	WTMR	R/W		- - 0 0 0 0 0 _B
00395D _H	Hour data register	WTHR	R/W		- - - 0 0 0 0 0 _B
00395E _H	Day data register	WTDR	R/W		0 0 - 0 0 0 0 1 _B
00395F _H	(Disabled)				
003960 _H to 00396F _H	LCD display RAM	VRAM	R/W	LCD controller/ driver	XXXXXXXX _B
003970 _H to 00397F _H	(Disabled)				
003980 _H	PWM1 compare register 0	PWC10	R/W	Stepping motor controller 0	XXXXXXXX _B
003981 _H					- - - - - XX _B
003982 _H	PWM2 compare register 0	PWC20	R/W		XXXXXXXX _B
003983 _H					- - - - - XX _B
003984 _H	PWM1 select register 0	PWS10	R/W		- - 0 0 0 0 0 _B
003985 _H	PWM2 select register 0	PWS20	R/W		- 0 0 0 0 0 0 _B

(Continued)

MB90925 Series

Address	Register name	Symbol	Read/write	Resource name	Initial value
003986 _H , 003987 _H	(Disabled)				
003988 _H	PWM1 compare register 1	PWC11	R/W	Stepping motor controller 1	XXXXXXXX _B
003989 _H					-----XX _B
00398A _H	PWM2 compare register 1	PWC21	R/W		XXXXXXXX _B
00398B _H					-----XX _B
00398C _H	PWM1 select register 1	PWS11	R/W		--000000 _B
00398D _H	PWM2 select register 1	PWS21	R/W		-0000000 _B
00398E _H , 00398F _H	(Disabled)				
003990 _H	PWM1 compare register 2	PWC12	R/W	Stepping motor controller 2	XXXXXXXX _B
003991 _H					-----XX _B
003992 _H	PWM2 compare register 2	PWC22	R/W		XXXXXXXX _B
003993 _H					-----XX _B
003994 _H	PWM1 select register 2	PWS12	R/W		--000000 _B
003995 _H	PWM2 select register 2	PWS22	R/W		-0000000 _B
003996 _H , 003997 _H	(Disabled)				
003998 _H	PWM1 compare register 3	PWC13	R/W	Stepping motor controller 3	XXXXXXXX _B
003999 _H					-----XX _B
00399A _H	PWM2 compare register 3	PWC23	R/W		XXXXXXXX _B
00399B _H					-----XX _B
00399C _H	PWM1 select register 3	PWS13	R/W		--000000 _B
00399D _H	PWM2 select register 3	PWS23	R/W		-0000000 _B
00399E _H to 0039FF _H	(Disabled)				
003A00 _H to 003AFF _H	Area reserved for CAN interface 0				
003B00 _H to 003BFF _H	(Disabled)				
003C00 _H to 003CFF _H	Area reserved for CAN interface 0				
003D00 _H to 003EFF _H	(Disabled)				

(Continued)

MB90925 Series

(Continued)

- Initial value symbols :
 - “0” : initial value 0
 - “1” : initial value 1
 - “X” : initial value undetermined
 - “-” : initial value undetermined (none)
- Write/read symbols :
 - “R/W” : read/write enabled
 - “R” : read only
 - “W” : write only

www.DataSheet4U.com • Addresses in the area 0000_H to 00FF_H are reserved for the principal functions of the MCU. Read access attempts to reserved areas will result in an “X” value. Also, write access to reserved areas is prohibited.

- * : P22/SEG0 to P27/SEG5 and P30/SEG6 to P35/SEG11 initially will be LCD segment output as LCD output control register LOCR1 (58_H) is “11111111_B” initially. To use port 2 and port 3 as the general-purpose input/output ports, set LOCR1 to “00000000_B” to disable the LCD segment output first.

MB90925 Series

• CAN Interface

Address	Register name	Symbol	Read/write	Initial value
000040 _H	Message buffer valid area	BVALR	R/W	0 0 0 0 0 0 0 0 _B
000041 _H				0 0 0 0 0 0 0 0 _B
000042 _H	Transmission request register	TREQR	R/W	0 0 0 0 0 0 0 0 _B
000043 _H				0 0 0 0 0 0 0 0 _B
000044 _H	Transmission cancel register	TCANR	W	0 0 0 0 0 0 0 0 _B
000045 _H				0 0 0 0 0 0 0 0 _B
000046 _H	Transmission completed register	TCR	R/W	0 0 0 0 0 0 0 0 _B
000047 _H				0 0 0 0 0 0 0 0 _B
000048 _H	Receiving completed register	RCR	R/W	0 0 0 0 0 0 0 0 _B
000049 _H				0 0 0 0 0 0 0 0 _B
00004A _H	Remote request receiving register	RRTRR	R/W	0 0 0 0 0 0 0 0 _B
00004B _H				0 0 0 0 0 0 0 0 _B
00004C _H	Receiving overrun register	ROVRR	R/W	0 0 0 0 0 0 0 0 _B
00004D _H				0 0 0 0 0 0 0 0 _B
00004E _H	Receiving interrupt enable register	RIER	R/W	0 0 0 0 0 0 0 0 _B
00004F _H				0 0 0 0 0 0 0 0 _B
003C00 _H	Control status register	CSR	R/W, R	0 0 - - - 0 0 0 _B
003C01 _H				0 - - - - 0 - 1 _B
003C02 _H	Last event indicator register	LEIR	R/W	- - - - - - - _B
003C03 _H				0 0 0 - 0 0 0 0 _B
003C04 _H	RX/TX error counter	RTEC	R	0 0 0 0 0 0 0 0 _B
003C05 _H				0 0 0 0 0 0 0 0 _B
003C06 _H	Bit timing register	BTR	R/W	- 1 1 1 1 1 1 1 1 _B
003C07 _H				1 1 1 1 1 1 1 1 _B
003C08 _H	IDE register	IDER	R/W	XXXXXXXX _B
003C09 _H				XXXXXXXX _B
003C0A _H	Transmission RTR register	TRTRR	R/W	0 0 0 0 0 0 0 0 _B
003C0B _H				0 0 0 0 0 0 0 0 _B
003C0C _H	Remote frame receiving wait register	RFWTR	R/W	XXXXXXXX _B
003C0D _H				XXXXXXXX _B
003C0E _H	Transmission interrupt enable register	TIER	R/W	0 0 0 0 0 0 0 0 _B
003C0F _H				0 0 0 0 0 0 0 0 _B

(Continued)

MB90925 Series

Address	Register name	Symbol	Read/write	Initial value
003C10 _H	Acceptance mask select register	AMSR	R/W	XXXXXXXX _B
003C11 _H				XXXXXXXX _B
003C12 _H				XXXXXXXX _B
003C13 _H				XXXXXXXX _B
003C14 _H	Acceptance mask register 0	AMR0	R/W	XXXXXXXX _B
003C15 _H				XXXXXXXX _B
003C16 _H				XXXXX- - - _B
003C17 _H				XXXXXXXX _B
003C18 _H	Acceptance mask register 1	AMR1	R/W	XXXXXXXX _B
003C19 _H				XXXXXXXX _B
003C1A _H				XXXXX- - - _B
003C1B _H				XXXXXXXX _B
003A00 _H to 003A1F _H	General-purpose RAM	—	R/W	XXXXXXXX _B to XXXXXXXX _B
003A20 _H	ID register 0	IDR0	R/W	XXXXXXXX _B
003A21 _H				XXXXXXXX _B
003A22 _H				XXXXX- - - _B
003A23 _H				XXXXXXXX _B
003A24 _H	ID register 1	IDR1	R/W	XXXXXXXX _B
003A25 _H				XXXXXXXX _B
003A26 _H				XXXXX- - - _B
003A27 _H				XXXXXXXX _B
003A28 _H	ID register 2	IDR2	R/W	XXXXXXXX _B
003A29 _H				XXXXXXXX _B
003A2A _H				XXXXX- - - _B
003A2B _H				XXXXXXXX _B
003A2C _H	ID register 3	IDR3	R/W	XXXXXXXX _B
003A2D _H				XXXXXXXX _B
003A2E _H				XXXXX- - - _B
003A2F _H				XXXXXXXX _B
003A30 _H	ID register 4	IDR4	R/W	XXXXXXXX _B
003A31 _H				XXXXXXXX _B
003A32 _H				XXXXX- - - _B
003A33 _H				XXXXXXXX _B

(Continued)

MB90925 Series

Address	Register name	Symbol	Read/write	Initial value
003A34 _H	ID register 5	IDR5	R/W	XXXXXXXX _B
003A35 _H				XXXXXXXX _B
003A36 _H				XXXXX- - - _B
003A37 _H				XXXXXXXX _B
003A38 _H	ID register 6	IDR6	R/W	XXXXXXXX _B
003A39 _H				XXXXXXXX _B
003A3A _H				XXXXX- - - _B
003A3B _H				XXXXXXXX _B
003A3C _H	ID register 7	IDR7	R/W	XXXXXXXX _B
003A3D _H				XXXXXXXX _B
003A3E _H				XXXXX- - - _B
003A3F _H				XXXXXXXX _B
003A40 _H	ID register 8	IDR8	R/W	XXXXXXXX _B
003A41 _H				XXXXXXXX _B
003A42 _H				XXXXX- - - _B
003A43 _H				XXXXXXXX _B
003A44 _H	ID register 9	IDR9	R/W	XXXXXXXX _B
003A45 _H				XXXXXXXX _B
003A46 _H				XXXXX- - - _B
003A47 _H				XXXXXXXX _B
003A48 _H	ID register 10	IDR10	R/W	XXXXXXXX _B
003A49 _H				XXXXXXXX _B
003A4A _H				XXXXX- - - _B
003A4B _H				XXXXXXXX _B
003A4C _H	ID register 11	IDR11	R/W	XXXXXXXX _B
003A4D _H				XXXXXXXX _B
003A4E _H				XXXXX- - - _B
003A4F _H				XXXXXXXX _B
003A50 _H	ID register 12	IDR12	R/W	XXXXXXXX _B
003A51 _H				XXXXXXXX _B
003A52 _H				XXXXX- - - _B
003A53 _H				XXXXXXXX _B

(Continued)

MB90925 Series

Address	Register name	Symbol	Read/write	Initial value
003A54H	ID register 13	IDR13	R/W	XXXXXXXXXB
003A55H				XXXXXXXXXB
003A56H				XXXXX- - -B
003A57H				XXXXXXXXXB
003A58H	ID register 14	IDR14	R/W	XXXXXXXXXB
003A59H				XXXXXXXXXB
003A5AH				XXXXX- - -B
003A5BH				XXXXXXXXXB
003A5CH	ID register 15	IDR15	R/W	XXXXXXXXXB
003A5DH				XXXXXXXXXB
003A5EH				XXXXX- - -B
003A5FH				XXXXXXXXXB
003A60H	DLC register 0	DLCR0	R/W	--- -XXXXB
003A61H				--- -XXXXB
003A62H	DLC register 1	DLCR1	R/W	--- -XXXXB
003A63H				--- -XXXXB
003A64H	DLC register 2	DLCR2	R/W	--- -XXXXB
003A65H				--- -XXXXB
003A66H	DLC register 3	DLCR3	R/W	--- -XXXXB
003A67H				--- -XXXXB
003A68H	DLC register 4	DLCR4	R/W	--- -XXXXB
003A69H				--- -XXXXB
003A6AH	DLC register 5	DLCR5	R/W	--- -XXXXB
003A6BH				--- -XXXXB
003A6CH	DLC register 6	DLCR6	R/W	--- -XXXXB
003A6DH				--- -XXXXB
003A6EH	DLC register 7	DLCR7	R/W	--- -XXXXB
003A6FH				--- -XXXXB
003A70H	DLC register 8	DLCR8	R/W	--- -XXXXB
003A71H				--- -XXXXB
003A72H	DLC register 9	DLCR9	R/W	--- -XXXXB
003A73H				--- -XXXXB
003A74H	DLC register 10	DLCR10	R/W	--- -XXXXB
003A75H				--- -XXXXB

(Continued)

MB90925 Series

Address	Register name	Symbol	Read/write	Initial value
003A76H	DLC register 11	DLCR11	R/W	--- -XXXX _B
003A77H				--- -XXXX _B
003A78H	DLC register 12	DLCR12	R/W	--- -XXXX _B
003A79H				--- -XXXX _B
003A7AH	DLC register 13	DLCR13	R/W	--- -XXXX _B
003A7BH				--- -XXXX _B
003A7CH	DLC register 14	DLCR14	R/W	--- -XXXX _B
003A7DH				--- -XXXX _B
003A7EH	DLC register 15	DLCR15	R/W	--- -XXXX _B
003A7FH				--- -XXXX _B
003A80H to 003A87H	Data register 0 (8 bytes)	DTR0	R/W	XXXXXXXX _B to XXXXXXXX _B
003A88H to 003A8FH	Data register 1 (8 bytes)	DTR1	R/W	XXXXXXXX _B to XXXXXXXX _B
003A90H to 003A97H	Data register 2 (8 bytes)	DTR2	R/W	XXXXXXXX _B to XXXXXXXX _B
003A98H to 003A9FH	Data register 3 (8 bytes)	DTR3	R/W	XXXXXXXX _B to XXXXXXXX _B
003AA0H to 003AA7H	Data register 4 (8 bytes)	DTR4	R/W	XXXXXXXX _B to XXXXXXXX _B
003AA8H to 003AAFH	Data register 5 (8 bytes)	DTR5	R/W	XXXXXXXX _B to XXXXXXXX _B
003AB0H to 003AB7H	Data register 6 (8 bytes)	DTR6	R/W	XXXXXXXX _B to XXXXXXXX _B
003AB8H to 003ABFH	Data register 7 (8 bytes)	DTR7	R/W	XXXXXXXX _B to XXXXXXXX _B
003AC0H to 003AC7H	Data register 8 (8 bytes)	DTR8	R/W	XXXXXXXX _B to XXXXXXXX _B
003AC8H to 003ACFH	Data register 9 (8 bytes)	DTR9	R/W	XXXXXXXX _B to XXXXXXXX _B

(Continued)

MB90925 Series

(Continued)

Address	Register name	Symbol	Read/write	Initial value
003AD0H to 003AD7H	Data register 10 (8 bytes)	DTR10	R/W	XXXXXXXX _B to XXXXXXXX _B
003AD8H to 003ADFH	Data register 11 (8 bytes)	DTR11	R/W	XXXXXXXX _B to XXXXXXXX _B
003AE0H to 003AE7H	Data register 12 (8 bytes)	DTR12	R/W	XXXXXXXX _B to XXXXXXXX _B
003AE8H to 003AEFH	Data register 13 (8 bytes)	DTR13	R/W	XXXXXXXX _B to XXXXXXXX _B
003AF0H to 003AF7H	Data register 14 (8 bytes)	DTR14	R/W	XXXXXXXX _B to XXXXXXXX _B
003AF8H to 003AFFH	Data register 15 (8 bytes)	DTR15	R/W	XXXXXXXX _B to XXXXXXXX _B

■ INTERRUPT SOURCES, INTERRUPT VECTORS, AND INTERRUPT CONTROL REGISTERS

Interrupt source	E ² OS corresponding	Interrupt vector		Interrupt control register		Priority *2
		Number	Address	ICR	Address	
Reset	×	#08	08H	FFFFDC _H	—	High ↑
INT9 instruction	×	#09	09H	FFFFD8 _H	—	
Exception processing	×	#10	0AH	FFFFD4 _H	—	
CAN0 RX	×	#11	0BH	FFFFD0 _H	ICR00	
CAN0 TX/NS	×	#12	0CH	FFFFCC _H		
(Reserved) *3	×	#13	0DH	FFFFC8 _H	ICR01	0000B1 _H *1
SIO *3	△	#14	0EH	FFFFC4 _H		
Input capture 0	△	#15	0FH	FFFFC0 _H	ICR02	0000B2 _H *1
DTP/external interrupt - ch.0 detected	△	#16	10H	FFFFBC _H		
Reload timer 0	△	#17	11H	FFFFB8 _H	ICR03	0000B3 _H *1
DTP/external interrupt - ch.1 detected	△	#18	12H	FFFFB4 _H		
Input capture 1	△	#19	13H	FFFFB0 _H	ICR04	0000B4 _H *1
DTP/external interrupt - ch.2 detected	△	#20	14H	FFFFAC _H		
Input capture 2	△	#21	15H	FFFFA8 _H	ICR05	0000B5 _H *1
DTP/external interrupt - ch.3 detected	△	#22	16H	FFFFA4 _H		
Input capture 3	△	#23	17H	FFFFA0 _H	ICR06	0000B6 _H *1
DTP/external interrupt - ch.4/ch.5 detected	△	#24	18H	FFFF9C _H		
PPG timer 0	△	#25	19H	FFFF98 _H	ICR07	0000B7 _H *1
DTP/external interrupt - ch.6/ch.7 detected	△	#26	1AH	FFFF94 _H		
PPG timer 1	△	#27	1BH	FFFF90 _H	ICR08	0000B8 _H *1
Reload timer 1	△	#28	1CH	FFFF8C _H		
PPG timer 2	○	#29	1DH	FFFF88 _H	ICR09	0000B9 _H *1
Real time watch timer	×	#30	1EH	FFFF84 _H		
Free-run timer overflow	×	#31	1FH	FFFF80 _H	ICR10	0000BA _H *1
A/D converter conversion end	○	#32	20H	FFFF7C _H		
Free-run timer clear	×	#33	21H	FFFF78 _H	ICR11	0000BB _H *1
Sound generator	×	#34	22H	FFFF74 _H		
Time-base timer	×	#35	23H	FFFF70 _H	ICR12	0000BC _H *1
Watchdog (sub clock)	×	#36	24H	FFFF6C _H		
UART 1 RX	◎	#37	25H	FFFF68 _H	ICR13	0000BD _H *1
UART 1 TX	△	#38	26H	FFFF64 _H		
UART 0 RX	◎	#39	27H	FFFF60 _H	ICR14	0000BE _H *1
UART 0 TX	△	#40	28H	FFFF5C _H		
Flash memory status	×	#41	29H	FFFF58 _H	ICR15	0000BF _H *1
Delay interrupt generator module	×	#42	2AH	FFFF54 _H		

(Continued)

MB90925 Series

(Continued)

◎ : Usable, with EI²OS stop function

○ : Usable

△ : Usable when interrupt sources sharing ICR are not in use

× : Unusable

*1 : • Peripheral functions sharing the ICR register have the same interrupt level.

• If peripheral functions sharing the ICR register are using expanded intelligent I/O services, one or the other cannot be used.

• When peripheral functions are sharing the ICR register and one specifies expanded intelligent I/O services, the interrupt from the other function cannot be used.

*2 : Priority applies when interrupts of the same level are generated.

*3 : SIO and CAN1 TX/NX will share IRQ3 in evaluation chip (MB90V925-101/102) .

■ ELECTRICAL CHARACTERISTICS

1. Absolute Maximum Ratings

Parameter	Symbol	Rating		Unit	Remarks
		Min	Max		
Power supply voltage*1	V _{CC}	V _{SS} - 0.3	V _{SS} + 6.0	V	
	AV _{CC}	V _{SS} - 0.3	V _{SS} + 6.0	V	AV _{CC} = V _{CC} *2
	AVRH	V _{SS} - 0.3	V _{SS} + 6.0	V	AV _{CC} ≥ AVRH*2
	DV _{CC}	V _{SS} - 0.3	V _{SS} + 6.0	V	DV _{CC} = V _{CC} *2
Input voltage*1	V _I	V _{SS} - 0.3	V _{CC} + 0.3	V	*3
Output voltage*1	V _O	V _{SS} - 0.3	V _{CC} + 0.3	V	
Maximum clamp current	I _{CLAMP}	- 400	+ 400	μA	*7
Total maximum clamp current	Σ I _{CLAMP}	—	4	mA	*7
“L” level maximum output current*4	I _{OL1}	—	15	mA	Other than P70 to P77 and P80 to P87
	I _{OL2}	—	40	mA	P70 to 77 and P80 to 87
“L” level average output current*5	I _{OLAV1}	—	4	mA	Other than P70 to P77 and P80 to P87
	I _{OLAV2}	—	30	mA	P70 to 77 and P80 to 87
“L” level maximum total output current	Σ I _{OL1}	—	100	mA	Other than P70 to P77 and P80 to P87
	Σ I _{OL2}	—	330	mA	P70 to 77 and P80 to 87
“L” level average total output current	Σ I _{OLAV1}	—	50	mA	Other than P70 to P77 and P80 to P87
	Σ I _{OLAV2}	—	250	mA	P70 to 77 and P80 to 87
“H” level maximum output current	I _{OH1} *4	—	-15	mA	Other than P70 to P77 and P80 to P87
	I _{OH2} *4	—	-40	mA	P70 to 77 and P80 to 87
“H” level average output current	I _{OHAV1} *5	—	-4	mA	Other than P70 to P77 and P80 to P87
	I _{OHAV2} *5	—	-30	mA	P70 to 77 and P80 to 87
“H” level maximum total output current	Σ I _{OH1}	—	-100	mA	Other than P70 to P77 and P80 to P87
	Σ I _{OH2}	—	-330	mA	P70 to 77 and P80 to 87
“H” level average total output current	Σ I _{OHAV1} *6	—	-50	mA	Other than P70 to P77 and P80 to P87
	Σ I _{OHAV2} *6	—	-250	mA	P70 to 77 and P80 to 87
Power consumption	P _D	—	500	mW	
Operating temperature	T _A	-40	+105	°C	
Storage temperature	T _{STG}	-55	+150	°C	

*1 : The parameter is based on V_{SS} = AV_{SS} = DV_{SS} = 0.0 V.

*2 : AV_{CC}, AVRH and DV_{CC} shall never exceed V_{CC}.
Also, AVRH shall never exceed AV_{CC}.

*3 : The maximum current to/from and input are limited by some means with external components, the I_{CLAMP} rating supersedes the V_I rating.

*4 : Maximum output current is defined as the peak value of the current of any one of the corresponding pins.

*5 : Average output current is defined as the value of the average current flowing over 100 ms at any one of the corresponding pins. The “average value” can be calculated from the formula of “operating current” times “operating factor”.

(Continued)

MB90925 Series

(Continued)

- *6 : Average total output current is defined as the value of the average current flowing over 100 ms at all of the corresponding pins. The “average value” can be calculated from the formula of “operating current” times “operating factor”.
- *7 :
 - Applicable to pins : P10 to P15, P50 to P57, P70 to P77, P80 to P87
 - Use within recommended operating conditions.
 - Use at DC voltage (current) .
 - The +B signal should always be applied with a limiting resistance placed between the +B signal and the microcontroller.
 - The value of the limiting resistance should be set so that when the +B signal is applied, the input current to the microcontroller pin does not exceed rated values, either instantaneously or for prolonged periods.
 - Note that when the microcontroller drive current is low, such as in the power saving modes, the +B input potential may pass through the protective diode and increase the potential at the V_{CC} pin, and this may affect other devices.
 - Note that if a +B signal is input when the microcontroller power supply is off (not fixed at 0 V) , the power supply is provided from the pins, so that incomplete operation may result.
 - Note that if the +B input is applied during power-on, the power supply is provided from the pins and the resulting power supply voltage may not be sufficient to operate the power-on reset.
 - Care must be taken not to leave the +B input pin open.
 - Note that analog system input/output pins (LCD drive pins, comparator input pins, etc.) cannot accept +B signal input.
 - Sample recommended circuits :

- Input/Output equivalent circuits

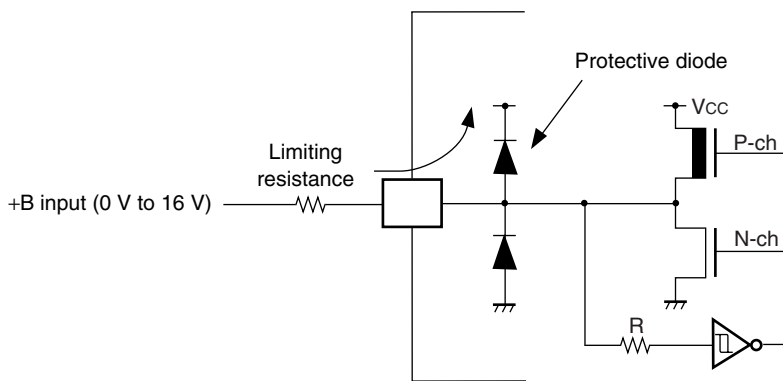

WARNING: Semiconductor devices can be permanently damaged by application of stress (voltage, current, temperature, etc.) in excess of absolute maximum ratings. Do not exceed these ratings.

2. Recommended Operating Conditions

($V_{SS} = DV_{SS} = AV_{SS} = 0.0\text{ V}$)

Parameter	Symbol	Value		Unit	Remarks
		Min	Max		
Power supply voltage	V_{CC}	3.7	5.5	V	(MB90F927/MB90F927S) Low voltage detection reset starts to work when power supply voltage is $4.0\text{ V} \pm 0.3\text{ V}$.
	AV_{CC} DV_{CC}	4.3	5.5	V	Holding stop operation status (MB90F927/MB90F927S)
Smoothing capacitor*	C_s	0.1	1.0	μF	Use a ceramic capacitor or other capacitor of equivalent frequency characteristics. A bypass capacitor on the V_{CC} pin should have a capacitance greater than C_s .
Operating temperature	T_A	-40	+105	$^{\circ}\text{C}$	

* : For smoothing capacitor C_s connections, refer to the illustration below.

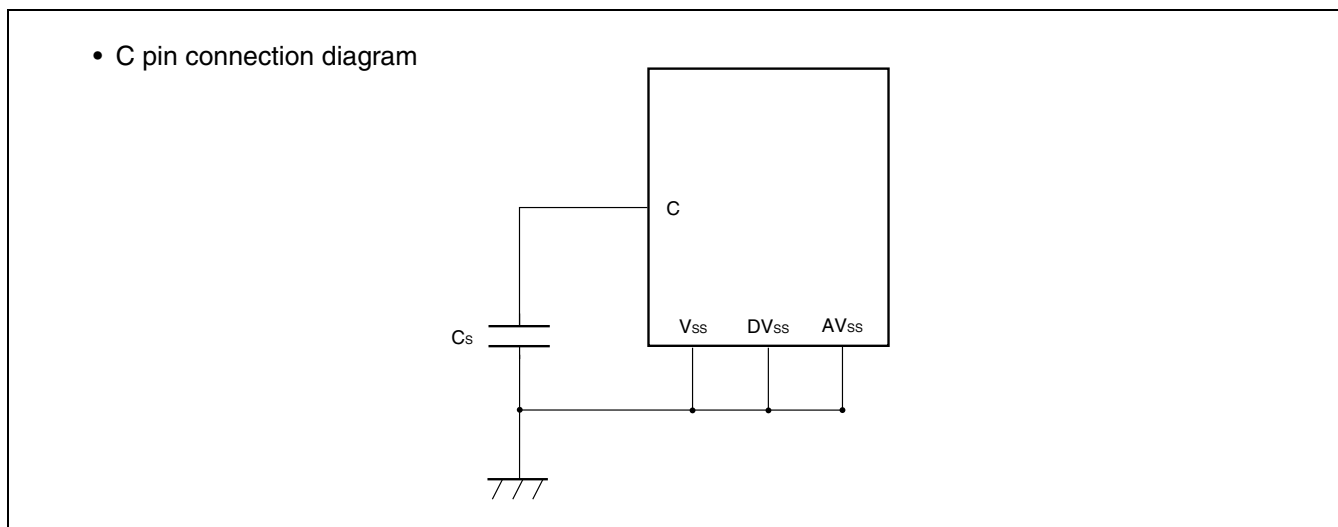

WARNING: The recommended operating conditions are required in order to ensure the normal operation of the semiconductor device. All of the device's electrical characteristics are warranted when the device is operated within these ranges.

Always use semiconductor devices within their recommended operating condition ranges. Operation outside these ranges may adversely affect reliability and could result in device failure.

No warranty is made with respect to uses, operating conditions, or combinations not represented on the data sheet. Users considering application outside the listed conditions are advised to contact their FUJITSU representatives beforehand.

MB90925 Series

3. DC Characteristics

($V_{CC} = 5.0\text{ V} \pm 10\%$, $V_{SS} = DV_{SS} = AV_{SS} = 0.0\text{ V}$, $T_A = -40\text{ }^\circ\text{C}$ to $+105\text{ }^\circ\text{C}$)

Parameter	Symbol	Pin name	Conditions	Value			Unit	Remarks
				Min	Typ	Max		
"H" level input voltage	V_{IHA}	—	—	$0.8 V_{CC}$	—	$V_{CC} + 0.3$	V	Pin inputs if Automotive input levels are selected*1
	V_{IHS2}	—	—	$0.8 V_{CC}$	—	$V_{CC} + 0.3$	V	Pin inputs if CMOS hysteresis input levels are selected*1 (0.8V _{CC} /0.2V _{CC} CMOS hysteresis is selected for P00, P03 and P51)
	V_{IHS1}	—	—	$0.7 V_{CC}$	—	$V_{CC} + 0.3$	V	Pin inputs if 0.7V _{CC} /0.3V _{CC} CMOS hysteresis input levels is selected for P00, P03 and P51.
	V_{IHR}	—	—	$0.8 V_{CC}$	—	$V_{CC} + 0.3$	V	$\overline{\text{RST}}$ input pin (CMOS hysteresis)
	V_{IHM}	—	—	$V_{CC} - 0.3$	—	$V_{CC} + 0.3$	V	MD pin*2
"L" level input voltage	V_{ILA}	—	—	$V_{SS} - 0.3$	—	$0.5 V_{CC}$	V	Pin inputs if Automotive input levels are selected*1
	V_{ILS2}	—	—	$V_{SS} - 0.3$	—	$0.2 V_{CC}$	V	Pin inputs if CMOS hysteresis input levels are selected*1 (0.8V _{CC} /0.2V _{CC} CMOS hysteresis is selected for P00, P03 and P51)
	V_{ILS1}	—	—	$V_{SS} - 0.3$	—	$0.3 V_{CC}$	V	Pin inputs if 0.7V _{CC} /0.3V _{CC} CMOS hysteresis input levels is selected for P00, P03 and P51.
	V_{ILR}	—	—	$V_{SS} - 0.3$	—	$0.2 V_{CC}$	V	$\overline{\text{RST}}$ input pin (CMOS hysteresis)
	V_{ILM}	—	—	$V_{SS} - 0.3$	—	$V_{SS} + 0.3$	V	MD pin*2

(Continued)

MB90925 Series

($V_{CC} = 5.0\text{ V} \pm 10\%$, $V_{SS} = DV_{SS} = AV_{SS} = 0.0\text{ V}$, $T_A = -40\text{ }^\circ\text{C}$ to $+105\text{ }^\circ\text{C}$)

Parameter	Symbol	Pin name	Conditions	Value			Unit	Remarks
				Min	Typ	Max		
Power supply current*3	I _{CC}	V _{CC}	Operating frequency F _{CP} = 16 MHz, normal operation	—	35	45	mA	Flash memory product
			Operating frequency F _{CP} = 16 MHz, writing Flash memory	—	50	60	mA	
			Operating frequency F _{CP} = 16 MHz, erasing Flash memory	—	50	60	mA	
	I _{CCS}		Operating frequency F _{CP} = 16 MHz, sleep mode	—	12	20	mA	
	I _{CTS}		Operating frequency F _{CP} = 2 MHz, time-base timer mode	—	0.4	1.0	mA	
	I _{CTSPLL}		Operating frequency F _{CP} = 16 MHz, PLL timer mode, External frequency = 4MHz	—	4	7	mA	
	I _{CCL}		Operating frequency F _{CP} = 8 kHz, T _A = + 25 °C, sub clock operation	—	90	200	μA	
	I _{CCLS}		Operating frequency F _{CP} = 8 kHz, T _A = + 25 °C, sub sleep operation	—	60	150	μA	
	I _{CCT}		Operating frequency F _{CP} = 8 kHz, T _A = + 25 °C, watch mode	—	60	130	μA	
	I _{CCH}		T _A = + 25 °C, stop mode	—	50	130	μA	
Input leakage current	I _{IL}	All input pins	V _{CC} = DV _{CC} = AV _{CC} = 5.5 V V _{SS} < V _I < V _{CC}	-5	—	+5	μA	
Input capacitance 1	C _{IN1}	Other than V _{CC} , V _{SS} , DV _{CC} , DV _{SS} , AV _{CC} , AV _{SS} , C, P70 to P77, P80 to P87	—	—	5	15	pF	

(Continued)

MB90925 Series

(Continued)

($V_{CC} = 5.0\text{ V} \pm 10\%$, $V_{SS} = DV_{SS} = AV_{SS} = 0.0\text{ V}$, $T_A = -40\text{ }^\circ\text{C}$ to $+105\text{ }^\circ\text{C}$)

Parameter	Symbol	Pin name	Conditions	Value			Unit	Remarks
				Min	Typ	Max		
Input capacitance 2	C_{IN2}	P70 to P77, P80 to P87	—	—	15	45	pF	
Pull-up resistance	R_{UP}	\overline{RST}	—	25	50	100	k Ω	
Pull-down resistance	R_{DOWN}	MD2	—	25	50	100	k Ω	Except Flash memory product
Output "H" voltage 1	V_{OH1}	Other than P70 to P77, P80 to P87	$V_{CC} = 4.5\text{ V}$ $I_{OH} = -4.0\text{ mA}$	$V_{CC} - 0.5$	—	—	V	
Output "H" voltage 2	V_{OH2}	P70 to P77, P80 to P87	$V_{CC} = 4.5\text{ V}$ $I_{OH} = -30.0\text{ mA}$	$V_{CC} - 0.5$	—	—	V	
Output "L" voltage 1	V_{OL1}	Other than P70 to P77, P80 to P87	$V_{CC} = 4.5\text{ V}$ $I_{OL} = 4.0\text{ mA}$	—	—	0.4	V	
Output "L" voltage 2	V_{OL2}	P70 to P77, P80 to P87	$V_{CC} = 4.5\text{ V}$ $I_{OL} = 30.0\text{ mA}$	—	—	0.55	V	
Large current output drive capacity variation 1	ΔV_{OH2}	PWM1Pn, PWM1Mn, PWM2Pn, PWM2Mn, (n = 0 to 3)	$V_{CC} = 4.5\text{ V}$ $I_{OH} = 30.0\text{ mA}$ V_{OH2} maximum variation	0	—	90	mV	*4
Large current output drive capacity variation 2	ΔV_{OL2}	PWM1Pn, PWM1Mn, PWM2Pn, PWM2Mn, (n = 0 to 3)	$V_{CC} = 4.5\text{ V}$ $I_{OH} = 30.0\text{ mA}$ V_{OL2} maximum variation	0	—	90	mV	*4
LCD internal divider resistance	R_{LCD}	V0 to V3	—	50	100	200	k Ω	
COM0 to COM3 output impedance	R_{VCOM}	COMn (n = 0 to 3)	—	—	—	2.5	k Ω	
SEG0 to SEG31 output impedance	R_{VSEG}	SEGN (n = 0 to 31)	—	—	—	15	k Ω	
LCD leakage current	I_{LCDC}	V0 to V3 COMm (m = 0 to 3) SEGN (n = 0 to 31)	—	-5.0	—	+5.0	μA	

*1 : All input pins except X0, X0A, MD0, MD1, and MD2.

*2 : MD0, MD1, and MD2 pins.

*3 : Power supply current values assume external clock feed from the X1 pin and X1A pin. Users must be aware that power supply current levels differ depending on whether an external clock or oscillator is used.

*4 : Defined as maximum variation in V_{OH2}/V_{OL2} with all ch.0 PWM1P0/PWM1M0/PWM2P0/PWM2M0 simultaneously ON. Similarly for other channels.

4. AC Characteristics

(1) Clock timing

($V_{CC} = 5.0 V \pm 10\%$, $V_{SS} = DV_{SS} = AV_{SS} = 0.0 V$, $T_A = -40\text{ }^\circ\text{C}$ to $+105\text{ }^\circ\text{C}$)

Parameter	Symbol	Pin name	Conditions	Value			Unit	Remarks
				Min	Typ	Max		
Base oscillation clock frequency	F_C	X0, X1	—	4	—	12	MHz	1/2 (when PLL stops)
				4	—	12	MHz	PLL x 1
				4	—	8	MHz	PLL x 2
				4	—	5.33	MHz	PLL x 3
				4	—	4	MHz	PLL x 4
	F_{LC}	X0A, X1A	—	32.768	—	kHz		
Base oscillation clock cycle time	t_{CYL}	X0, X1	—	250	—	ns		
		X0A, X1A	—	30.5	—	μs		
Input clock pulse width	P_{WH}, P_{WL}	X0	—	10	—	ns	Use duty ratio of 40 to 60% as a guideline	
		X0A	—	15.2	—	μs		
Input clock rise and fall time	t_{cr}, t_{cf}	X0, X0A	—	—	5	ns	external clock signal	
Internal operating clock frequency	F_{CP}	—	—	2	—	16	MHz	Using main clock (PLL clock)
		—	—	—	8.192	—	kHz	Using sub clock
Internal operating clock cycle time	t_{CP}	—	—	62.5	—	500	ns	Using main clock (PLL clock)
		—	—	—	122.1	—	μs	Using sub clock

• X0 clock timing

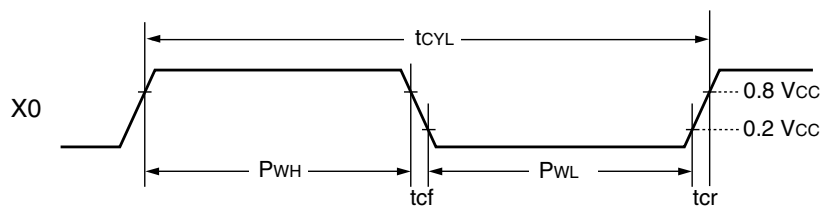

• X0A clock timing

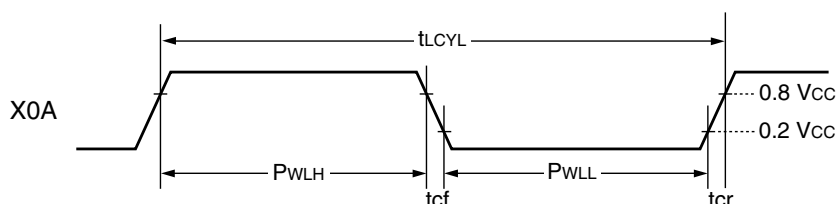

MB90925 Series

- Range of guaranteed operation

Relation between internal operating clock frequency and power supply voltage

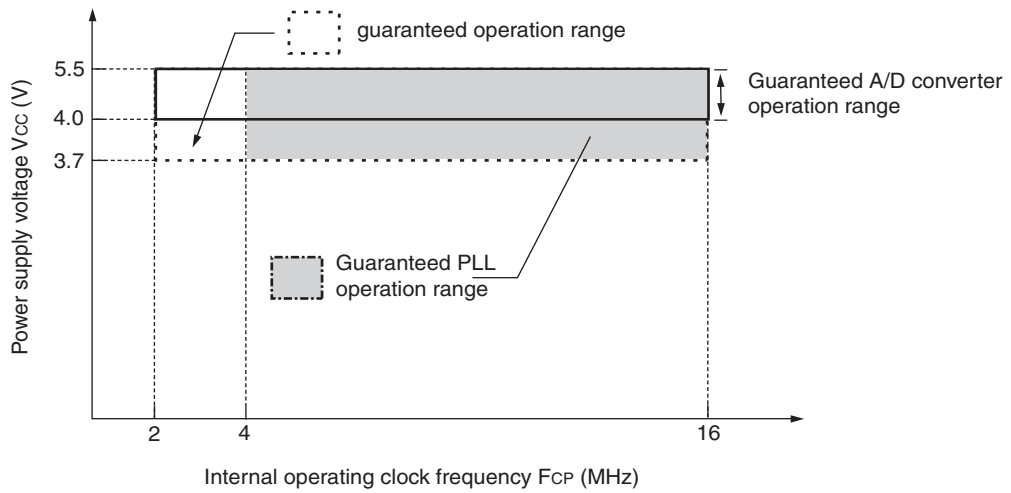

Note : The MB90F927/ MB90F927S enters reset mode at power supply voltage below $4\text{ V} \pm 0.3\text{ V}$.

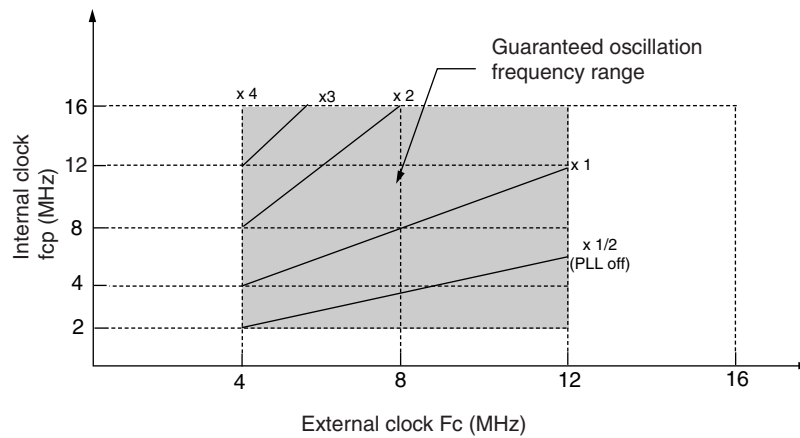

(2) Reset input

($V_{CC} = 5.0\text{ V} \pm 10\%$, $V_{SS} = AV_{SS} = 0.0\text{ V}$, $T_A = -40\text{ }^\circ\text{C}$ to $+105\text{ }^\circ\text{C}$)

Parameter	Symbol	Pin name	Value		Unit	Remarks
			Min	Max		
Reset input time	t_{RSTL}	\overline{RST}	500	—	ns	At normal operation
			Oscillator oscillation time* + 100 μs	—	ms	At stop mode, sub clock mode, sub sleep mode, and watch mode
			100	—	μs	At time-base timer mode

*: Oscillator's oscillation time is the time that the amplitude reaches 90%. The oscillation time of a crystal oscillator is between several ms and tens of ms. The oscillation time of a ceramic oscillator is between hundreds of μs and several ms. The oscillation time of an external clock is 0 ms.

- At normal operation

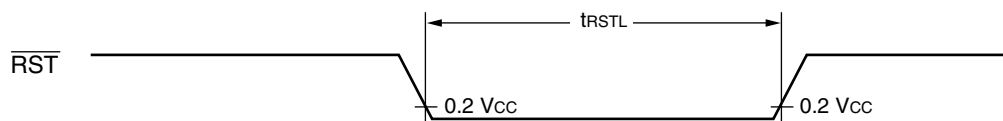

- At stop mode, sub clock mode, sub sleep mode, watch mode, and power-on

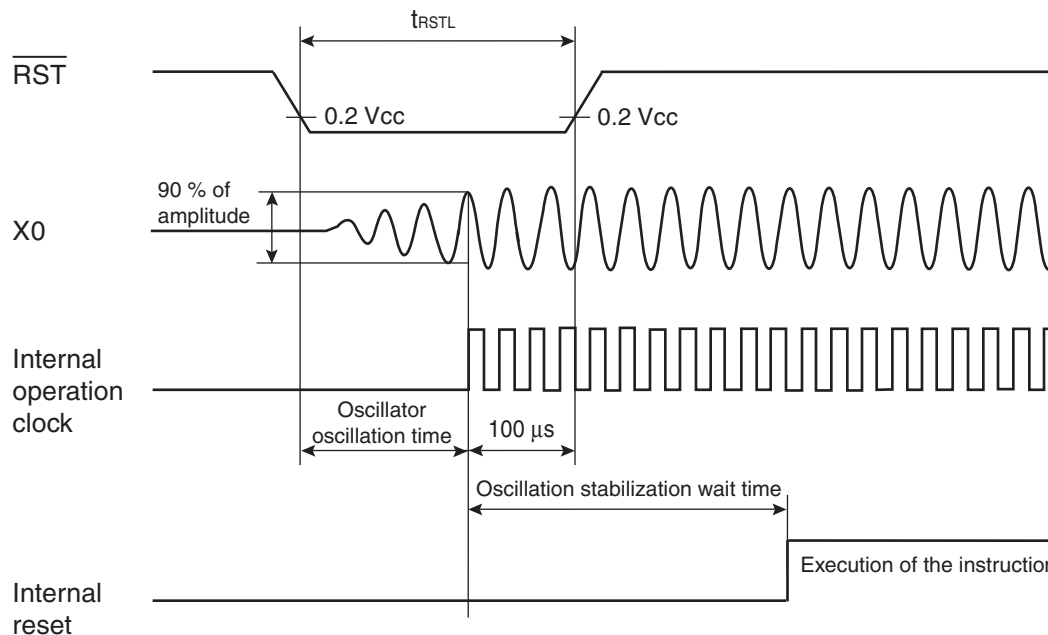

MB90925 Series

(3) Power-on reset

($V_{SS} = 0.0\text{ V}$, $T_A = -40\text{ }^\circ\text{C}$ to $+105\text{ }^\circ\text{C}$)

Parameter	Symbol	Pin name	Conditions	Value		Unit	Remarks
				Min	Max		
Power supply rise time	t_R	V_{CC}	—	0.05	30	ms	
Power supply start voltage	V_{OFF}			—	0.2	V	
Power supply attained voltage	V_{ON}			2.7	—	V	
Power supply cutoff time	t_{OFF}			50	—	ms	Waiting time until power-on

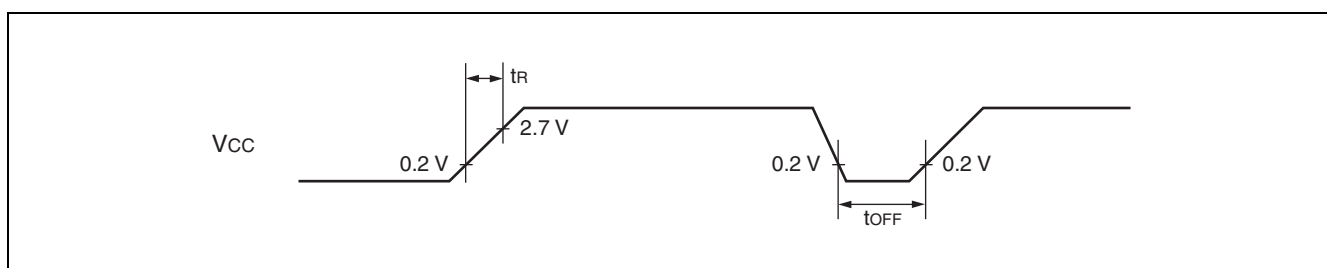

Note : Extreme variations in power supply voltage may activate a power-on reset. As the illustration below shows, when varying power supply voltage during operation, the use of a smooth voltage rise with suppressed fluctuation is recommended. Also in this situation, the PLL clock on the device should not be used, however it is permissible to use the PLL clock during a voltage drop of 1V/s or less.

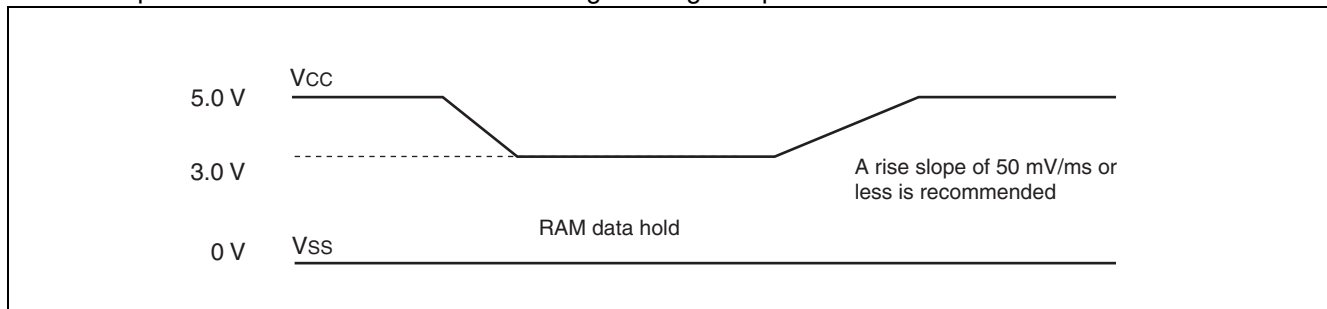

(4) SIO timing

($V_{CC} = 5.0 V \pm 10\%$, $V_{SS} = AV_{SS} = 0.0 V$, $T_A = -40\text{ }^\circ\text{C}$ to $+105\text{ }^\circ\text{C}$)

Parameter	Symbol	Pin name	Conditions	Value		Unit
				Min	Max	
Serial clock cycle time	t_{SCYC}	SCK	Internal shift clock mode output pin $C_L = 80\text{ pF} + 1\text{TTL}$	$8 t_{CP}$	—	ns
SCK $\downarrow \rightarrow$ SO delay time	t_{SLOV}	SCK, SO		-80	+80	ns
Valid SI \rightarrow SCK \uparrow	t_{IVSH}	SCK, SI		100	—	ns
SCK $\uparrow \rightarrow$ valid SI hold time	t_{SHIX}		60	—	ns	
Serial clock "H" pulse width	t_{SHSL}	SCK	External shift clock mode output pin $C_L = 80\text{ pF} + 1\text{TTL}$	$4 t_{CP}$	—	ns
Serial clock "L" pulse width	t_{SLSH}			$4 t_{CP}$	—	ns
SCK $\downarrow \rightarrow$ SO delay time	t_{SLOV}	SCK, SO		—	150	ns
Valid SI \rightarrow SCK \uparrow	t_{IVSH}	SCK, SI	60	—	ns	
SCK $\uparrow \rightarrow$ valid SI hold time	t_{SHIX}		60	—	ns	

- Notes :
- AC ratings are for CLK synchronous mode.
 - C_L is load capacitance connected to pin during testing.
 - t_{CP} is internal operating clock cycle time. Refer to "(1) Clock timing".

• Internal shift clock mode

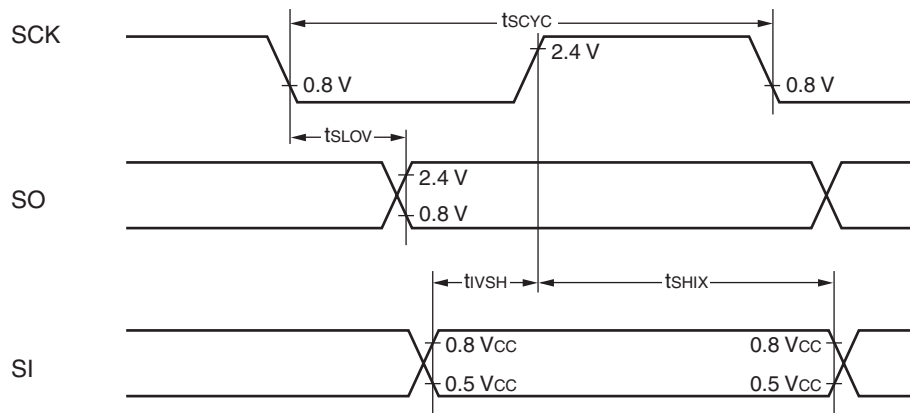

• External shift clock mode

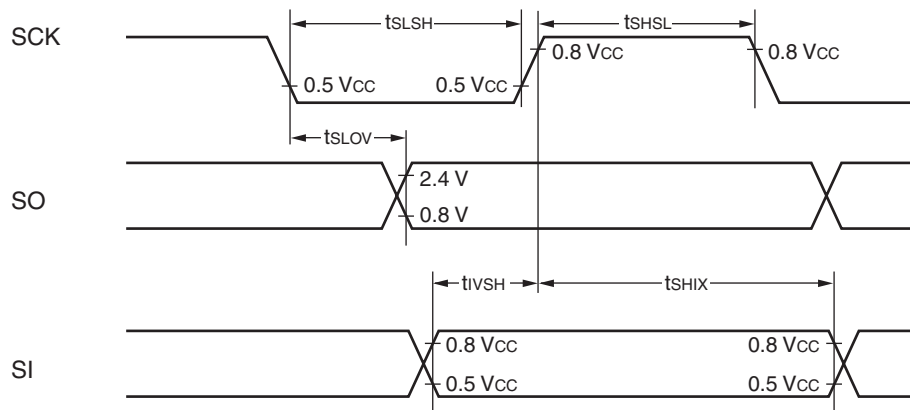

MB90925 Series

(5) UART0/1 (LIN/SCI)

- Bit setting: ESCR0/1:SCES=0, ECCR0/1:SCDE=0

($V_{CC} = 5.0\text{ V} \pm 10\%$, $V_{SS} = AV_{SS} = 0.0\text{ V}$, $T_A = -40\text{ }^\circ\text{C}$ to $+105\text{ }^\circ\text{C}$)

Parameter	Symbol	Pin name	Conditions	Value		Unit
				Min	Max	
Serial clock cycle time	t_{SCYC}	SCK0, SCK1	Internal shift clock mode output pins are $C_L = 80\text{ pF} + 1\text{ TTL}$	$5 t_{CP}$	—	ns
SCK ↓ → SOT delay time	t_{SLOVI}	SCK0, SCK1, SOT0, SOT1		– 50	+ 50	ns
Valid SIN → SCK ↑	t_{IVSHI}	SCK0, SCK1, SIN0, SIN1		$t_{CP} + 80$	—	ns
SCK ↑ → valid SIN hold time	t_{SHIXI}			0	—	ns
Serial clock “L” pulse width	t_{SLSH}	SCK0, SCK1	External shift clock mode output pins are $C_L = 80\text{ pF} + 1\text{ TTL}$	$t_{CP} + 10$	—	ns
Serial clock “H” pulse width	t_{SHSL}			$3 t_{CP} - t_R$	—	ns
SCK ↓ → SOT delay time	t_{SLOVE}	SCK0, SCK1, SOT0, SOT1		—	$2 t_{CP} + 60$	ns
Valid SIN → SCK ↑	t_{IVSHE}	SCK0, SCK1, SIN0, SIN1		30	—	ns
SCK ↑ → valid SIN hold time	t_{SHIXE}			$t_{CP} + 30$	—	ns
SCK fall time	t_F	SCK0, SCK1		—	10	ns
SCK rise time	t_R			—	10	ns

- Notes :
- AC characteristic in CLK synchronized mode.
 - C_L is load capacity value of pins when testing.
 - t_{CP} is internal operating clock cycle time (machine clock). Refer to “ (1) Clock timing”.

- Internal shift clock mode

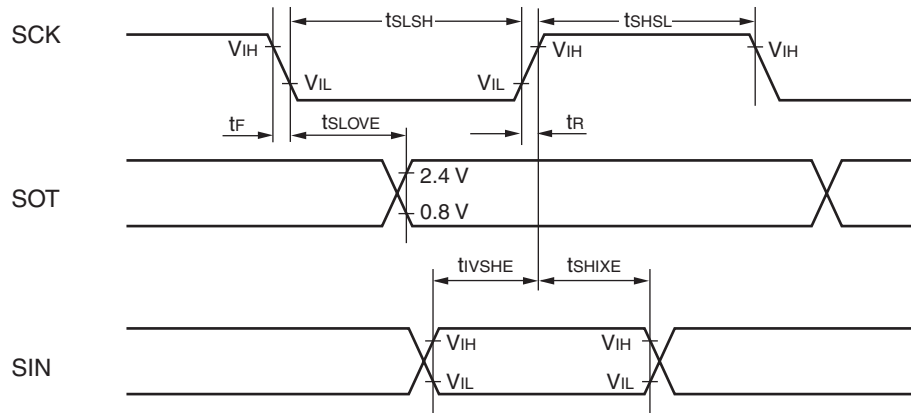

- External shift clock mode

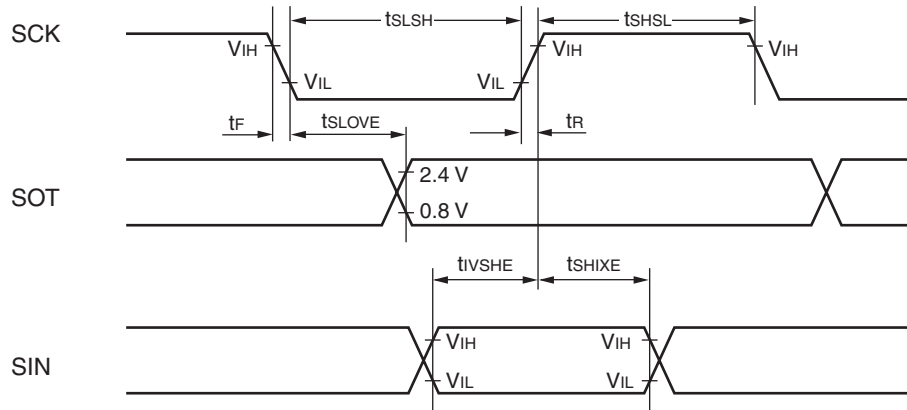

MB90925 Series

• Bit setting: ESCR0/1:SCES=1, ECCR0/1:SCDE=0

($V_{CC} = 5.0\text{ V} \pm 10\%$, $V_{SS} = AV_{SS} = 0.0\text{ V}$, $T_A = -40\text{ }^\circ\text{C}$ to $+105\text{ }^\circ\text{C}$)

Parameter	Symbol	Pin name	Conditions	Value		Unit
				Min	Max	
Serial clock cycle time	t_{SCYC}	SCK0, SCK1	Internal shift clock mode output pins are $C_L = 80\text{ pF} + 1\text{TTL}$	$5 t_{CP}$	—	ns
SCK \uparrow \rightarrow SOT delay time	t_{SLOVI}	SCK0, SCK1, SOT0, SOT1		- 50	+ 50	ns
Valid SIN \rightarrow SCK \downarrow	t_{IVSHI}	SCK0, SCK1, SIN0, SIN1		$t_{CP} + 80$	—	ns
SCK \downarrow \rightarrow valid SIN hold time	t_{SHIXI}			0	—	ns
Serial clock "H" pulse width	t_{SHSL}	SCK0, SCK1	External shift clock mode output pins are $C_L = 80\text{ pF} + 1\text{TTL}$	$3 t_{CP} - t_R$	—	ns
Serial clock "L" pulse width	t_{SLSH}			$t_{CP} + 10$	—	ns
SCK \uparrow \rightarrow SOT delay time	t_{SLOVE}	SCK0, SCK1, SOT0, SOT1		—	$2 t_{CP} + 60$	ns
Valid SIN \rightarrow SCK \downarrow	t_{IVSHE}	SCK0, SCK1, SIN0, SIN1		30	—	ns
SCK \downarrow \rightarrow valid SIN hold time	t_{SHIX}			$t_{CP} + 30$	—	ns
SCK fall time	t_F	SCK0, SCK1		—	10	ns
SCK rise time	t_R			—	10	ns

- Internal shift clock mode

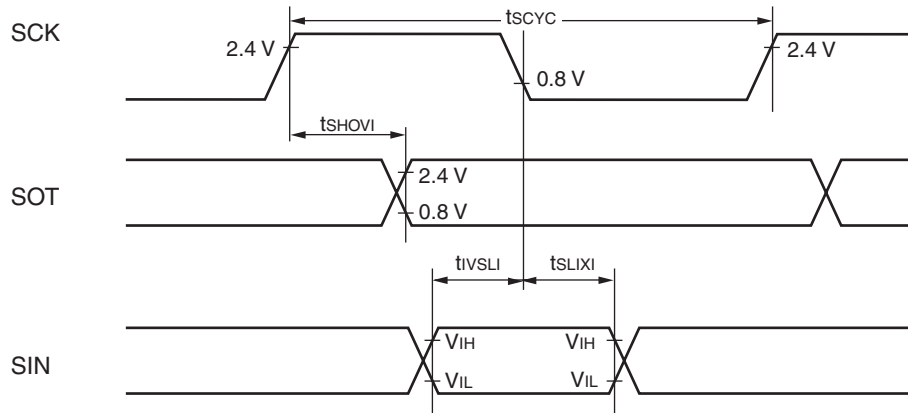

- External shift clock mode

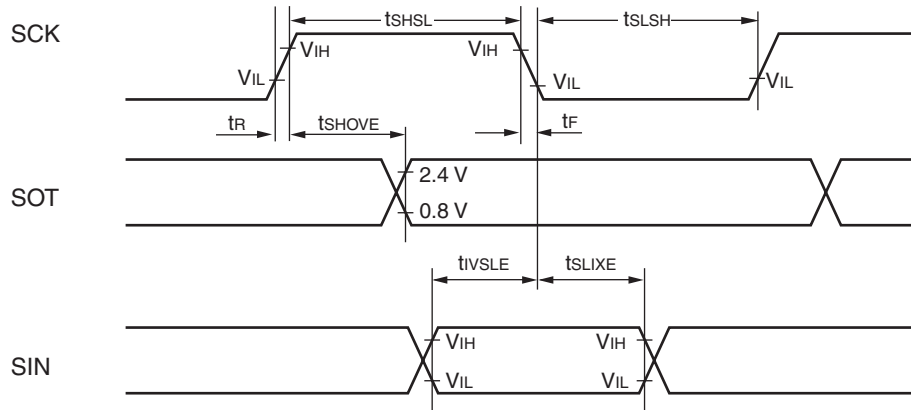

MB90925 Series

• Bit setting: ESCR0/1:SCES=0, ECCR0/1:SCDE=1

($V_{CC} = 5.0\text{ V} \pm 10\%$, $V_{SS} = AV_{SS} = 0.0\text{ V}$, $T_A = -40\text{ }^\circ\text{C}$ to $+105\text{ }^\circ\text{C}$)

Parameter	Symbol	Pin name	Conditions	Value		Unit
				Min	Max	
Serial clock cycle time	t_{SCYC}	SCK0, SCK1	Internal clock operation output pins are $C_L = 80\text{ pF} + 1\text{ TTL}$	$5 t_{CP}$	—	ns
SCK \uparrow \rightarrow SOT delay time	t_{SHOVI}	SCK0, SCK1, SOT0, SOT1		- 50	+ 50	ns
Valid SIN \rightarrow SCK \downarrow	t_{IVSLI}	SCK0, SCK1, SIN0, SIN1		$t_{CP} + 80$	—	ns
SCK \downarrow \rightarrow valid SIN hold time	t_{SLIXI}			0	—	ns
SOT \rightarrow SCK \downarrow delay time	t_{SOVLI}	SCK0, SCK1, SOT0, SOT1		$3 t_{CP} - 70$	—	ns

Notes : t_{CP} is the machine clock cycle time (Unit : ns) . Refer to “ (1) Clock timing”rating for t_{CP} .

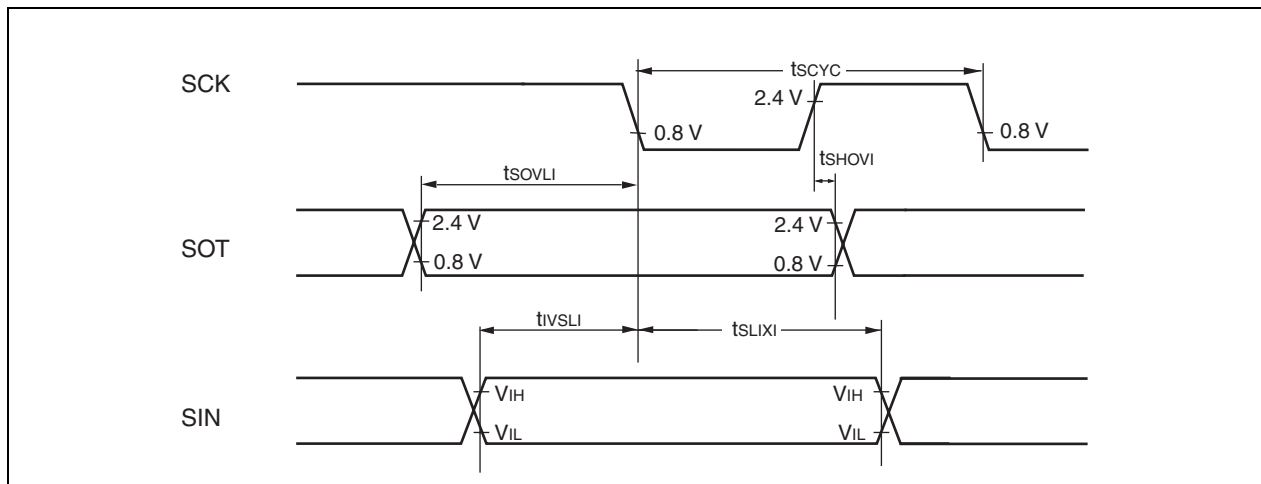

MB90925 Series

• Bit setting: ESCR0/1:SCES=1, ECCR0/1:SCDE=1

($V_{CC} = 5.0\text{ V} \pm 10\%$, $V_{SS} = AV_{SS} = 0.0\text{ V}$, $T_A = -40\text{ }^\circ\text{C}$ to $+105\text{ }^\circ\text{C}$)

Parameter	Symbol	Pin name	Conditions	Value		Unit
				Min	Max	
Serial clock cycle time	t_{SCYC}	SCK0, SCK1	Internal clock operation output pins are $C_L = 80\text{ pF} + 1\text{ TTL}$	$5 t_{CP}$	—	ns
SCK \downarrow \rightarrow SOT delay time	t_{SLOVI}	SCK0, SCK1, SOT0, SOT1		- 50	+ 50	ns
Valid SIN \rightarrow SCK \uparrow	t_{IVSHI}	SCK0, SCK1, SIN0, SIN1		$t_{CP} + 80$	—	ns
SCK \uparrow \rightarrow valid SIN hold time	t_{SHIXI}	SCK0, SCK1, SIN0, SIN1		0	—	ns
SOT \rightarrow SCK \uparrow delay time	t_{SOVHI}	SCK0, SCK1, SOT0, SOT1		$3 t_{CP} - 70$	—	ns

Notes : t_{CP} is the machine clock cycle time (Unit : ns) . Refer to “ (1) Clock timing”rating for t_{CP} .

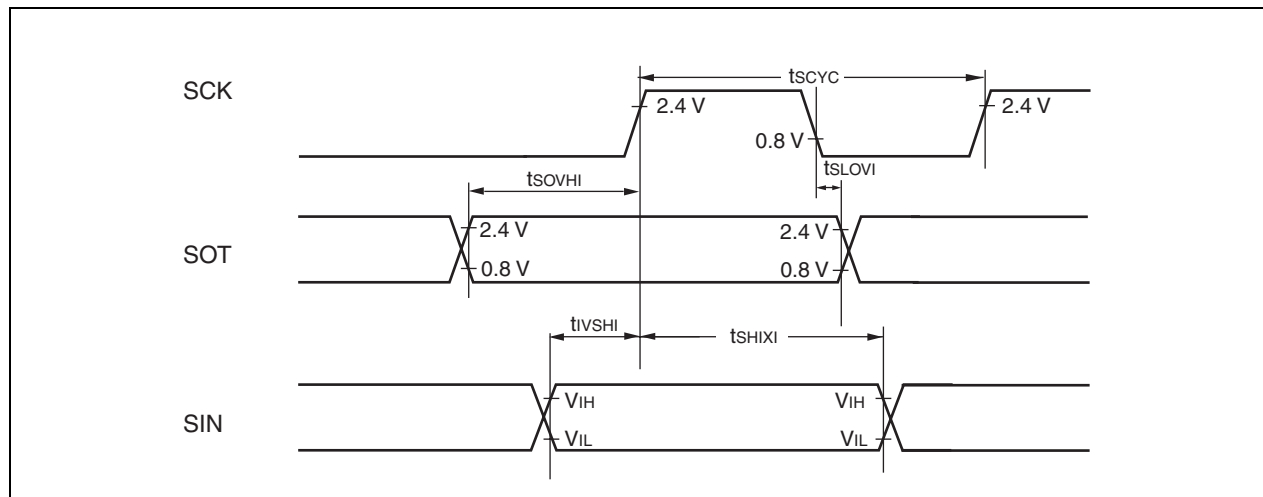

MB90925 Series

(6) Timer input timing

($V_{CC} = 5.0\text{ V} \pm 10\%$, $V_{SS} = AV_{SS} = 0.0\text{ V}$, $T_A = -40\text{ }^\circ\text{C}$ to $+105\text{ }^\circ\text{C}$)

Parameter	Symbol	Pin name	Conditions	Value		Unit
				Min	Max	
Input pulse width	t_{TIWH} t_{TIWL}	TIN0, TIN1, IN0 to IN3	—	4 t_{CP}	—	ns

Note : t_{CP} is internal operating clock cycle time. Refer to “(1) Clock timing”.

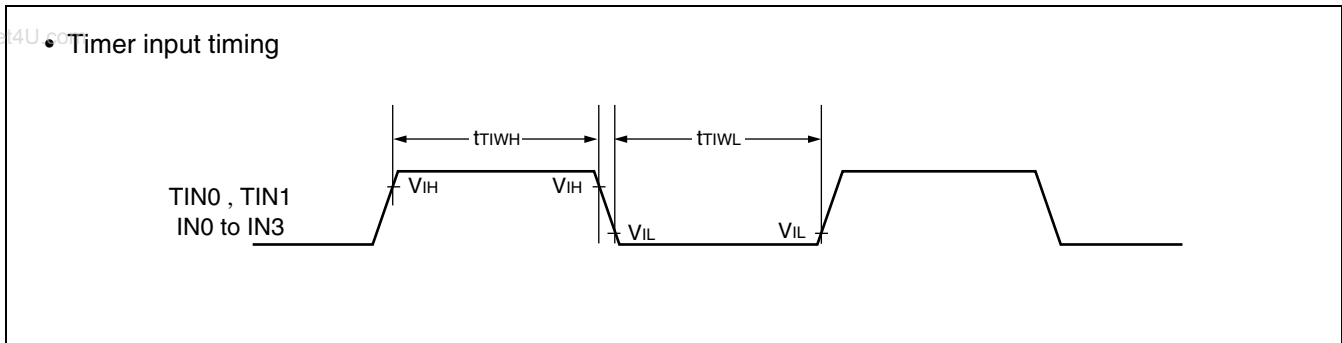

(7) Trigger input timing

($V_{CC} = 5.0\text{ V} \pm 10\%$, $V_{SS} = AV_{SS} = 0.0\text{ V}$, $T_A = -40\text{ }^\circ\text{C}$ to $+105\text{ }^\circ\text{C}$)

Parameter	Symbol	Pin name	Conditions	Value		Unit
				Min	Max	
Input pulse width	t_{TRGH} , t_{TRGL}	INT0 to INT7	—	200	—	ns
		ADTG	—	$t_{CP} + 200$	—	ns

Note : t_{CP} is internal operating clock cycle time (machine clock) . Refer to “ (1) Clock timing”.

- Trigger input timing

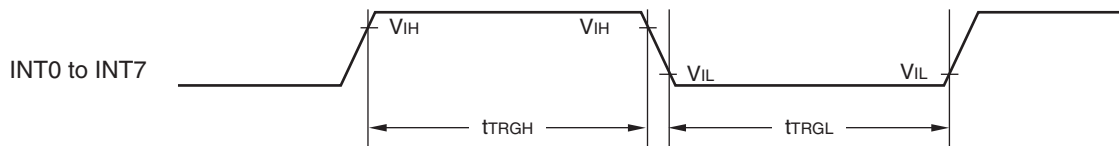

MB90925 Series

(8) Low voltage detection

($V_{SS} = AV_{SS} = 0.0\text{ V}$, $T_A = -40\text{ }^\circ\text{C}$ to $+105\text{ }^\circ\text{C}$)

Parameter	Symbol	Pin name	Conditions	Value			Unit	Remarks
				Min	Typ	Max		
Detection voltage	V_{DL}	V_{CC}	—	3.7	4.0	4.3	V	During voltage drop
Hysteresis width	V_{HYS}	V_{CC}	—	0.1	—	—	V	During voltage rise
Power supply voltage fluctuation ratio	dV/dt	V_{CC}	—	-0.1	—	+0.02	V/ μs	
Detection delay time	t_d	—	—	—	—	35	μs	

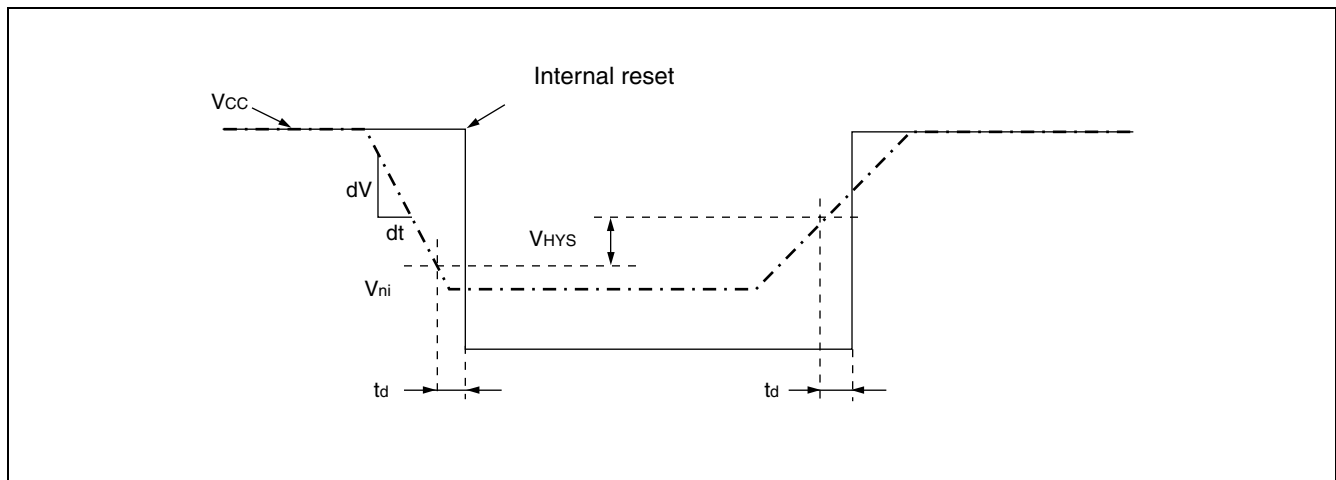

5. A/D Converter

(1) Electrical Characteristics

($V_{CC} = AV_{CC} = 5.0 \text{ V} \pm 10\%$, $3.0 \text{ V} \leq AVR_{H} - AV_{SS}$, $V_{SS} = AV_{SS} = 0.0 \text{ V}$, $T_A = -40 \text{ }^\circ\text{C}$ to $+105 \text{ }^\circ\text{C}$)

Parameter	Symbol	Pin name	Value			Unit	Remarks
			Min	Typ	Max		
Resolution	—	—	—	—	10	bit	
Total error	—	—	—	—	± 3.0	LSB	
Non-linear error	—	—	—	—	± 2.5	LSB	
Differential linear error	—	—	—	—	± 1.9	LSB	
Zero transition voltage	V_{OT}	AN0 to AN7	$AV_{SS} - 1.5 \text{ LSB}$	$AV_{SS} + 0.5 \text{ LSB}$	$AV_{SS} + 2.5 \text{ LSB}$	V	1 LSB = ($AVR_{H} - AV_{SS}$) / 1024
Full scale transition voltage	V_{FST}	AN0 to AN7	$AVR_{H} - 3.5 \text{ LSB}$	$AVR_{H} - 1.5 \text{ LSB}$	$AVR_{H} + 0.5 \text{ LSB}$	V	
Sampling time	t_{SMP}	—	1.4	—	16500	μs	$4.5 \text{ V} \leq AV_{CC} \leq 5.5 \text{ V}$
			2.0				$4.0 \text{ V} \leq AV_{CC} \leq 4.5 \text{ V}$
Compare time	t_{CMP}	—	0.5	—	—	μs	$4.5 \text{ V} \leq AV_{CC} \leq 5.5 \text{ V}$
			1.2				$4.0 \text{ V} \leq AV_{CC} \leq 4.5 \text{ V}$
Analog port input current	I_{AIN}	AN0 to AN7	-0.3	—	+0.3	μA	
Analog input voltage	V_{AIN}	AN0 to AN7	AV_{SS}	—	AVR_{H}	V	
Reference voltage	AVR_{H}	AVR_{H}	$AV_{SS} + 2.7$	—	AV_{CC}	V	
Power supply current	I_A	AV_{CC}	—	3.5	7.5	mA	
	I_{AH}		—	—	5	μA	*
Reference voltage supply current	I_R	AVR_{H}	—	600	900	μA	$V_{AVR_{H}} = 5.0 \text{ V}$
	I_{RH}	AVR_{H}	—	—	5	μA	*
Inter-channel variation	—	AN0 to AN7	—	—	4	LSB	

* : Defined as supply current (when $V_{CC} = AV_{CC} = AVR_{H} = 5.0 \text{ V}$) with A/D converter not operating, and CPU in stop mode.

MB90925 Series

- Notes of the external impedance of the analog input and its sampling time

A/D converter with sample and hold circuit. If the external impedance is too high to keep sufficient sampling time, the analog voltage charged to the internal sample and hold capacitor is insufficient, adversely affecting A/D conversion precision. Therefore, to satisfy the A/D conversion precision standard, consider the relationship between the external impedance and minimum sampling time and either adjust the register value and operating frequency or decrease the external impedance so that the sampling time is longer than the minimum value. Also, if the sampling time cannot be sufficient, connect a capacitor of about 0.1 μF to the analog input pin.

- Analog input equivalent circuit

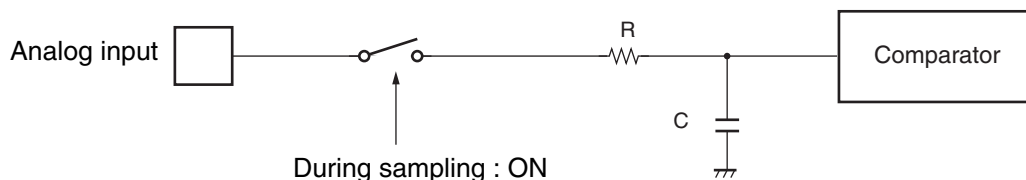

MB90F927/MB90F927S

	R	C
$4.5 \text{ V} \leq AV_{cc} \leq 5.5 \text{ V}$	2.0 k Ω (Max)	16.0 pF (Max)
$4.0 \text{ V} \leq AV_{cc} \leq 4.5 \text{ V}$	8.2 k Ω (Max)	16.0 pF (Max)

MB90V925-101/102

	R	C
$4.5 \text{ V} \leq AV_{cc} \leq 5.5 \text{ V}$	2.0 k Ω (Max)	14.4 pF (Max)
$4.0 \text{ V} \leq AV_{cc} \leq 4.5 \text{ V}$	8.2 k Ω (Max)	14.4 pF (Max)

Note : The values are reference values.

- The relationship between the external impedance and minimum sampling time
- At $4.5\text{ V} \leq AV_{CC} \leq 5.5\text{ V}$

(External impedance = 0 k Ω to 100 k Ω)

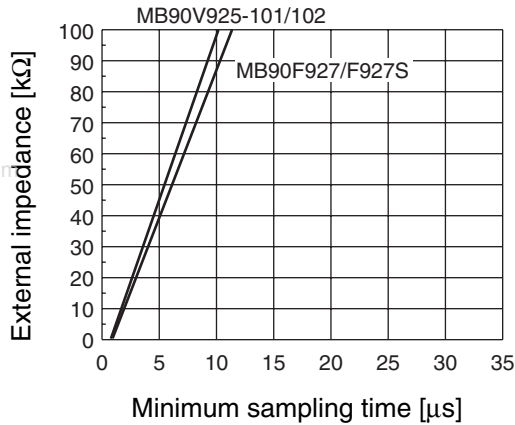

(External impedance = 0 k Ω to 20 k Ω)

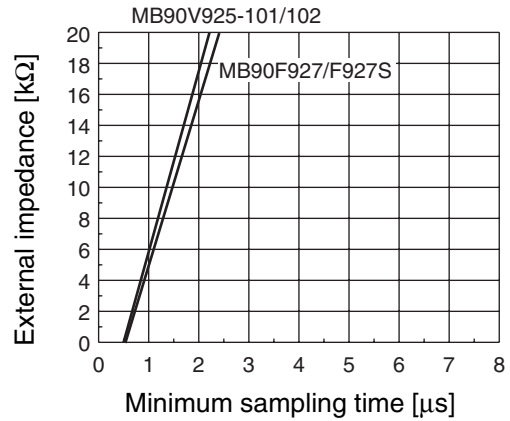

- At $4.0\text{ V} \leq AV_{CC} \leq 4.5\text{ V}$

(External impedance = 0 k Ω to 100 k Ω)

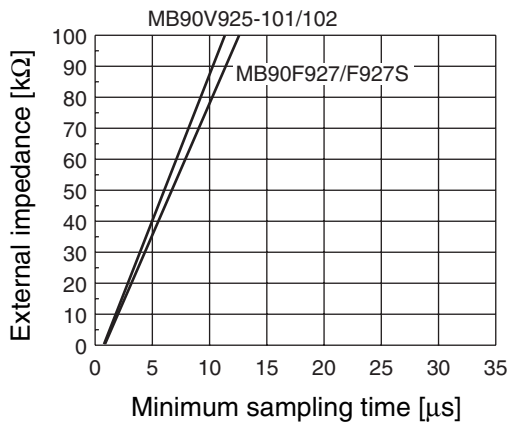

(External impedance = 0 k Ω to 20 k Ω)

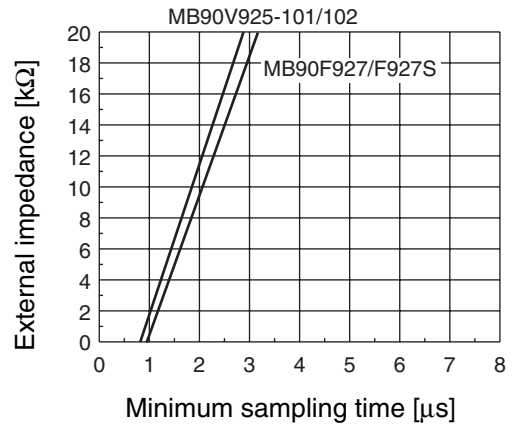

- About errors

As $|AV_{RH} - AV_{SS}|$ becomes smaller, values of relative errors grow larger.

MB90925 Series

(2) Definition of terms

Resolution : Analog changes that are identifiable with the A/D converter.

Non-Linear error : The deviation of the straight line connecting the zero transition point (“00 0000 0000” ↔ “00 0000 0001”) with the full-scale transition point (“11 1111 1110” ↔ “11 1111 1111”) from actual conversion characteristics.

Differential linear error : The deviation of input voltage needed to change the output code by 1 LSB from the ideal value.

Total error : The total error is defined as a difference between the actual value and the theoretical value, which includes zero-transition error/full-scale transition error and linear error.

www.DataSheet4U.com

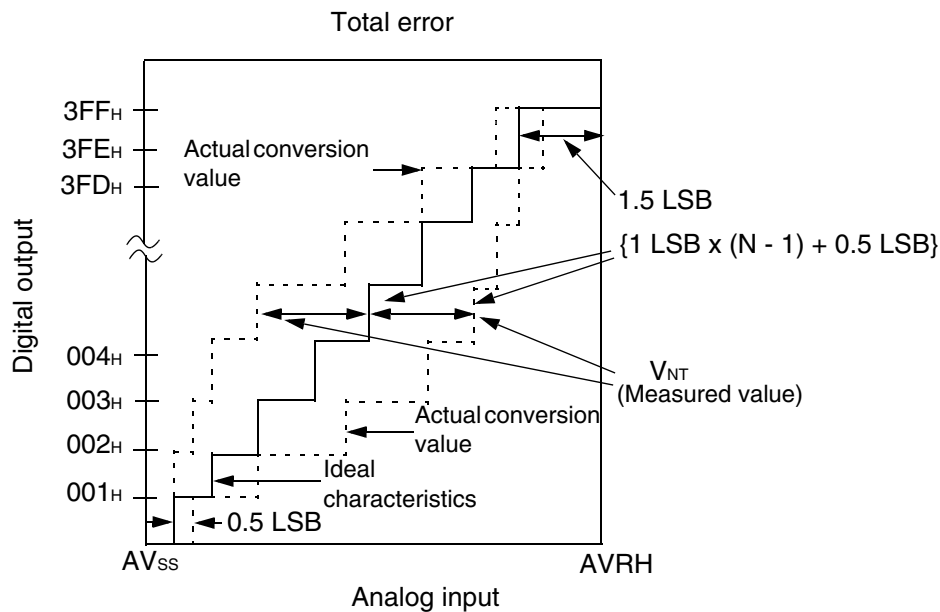

$$\text{Total error for digital output } N = \frac{V_{NT} - \{1 \text{ LSB} \times (N - 1) + 0.5 \text{ LSB}\}}{1 \text{ LSB}} \quad [\text{LSB}]$$

$$1 \text{ LSB (Ideal)} = \frac{AVRH - AVSS}{1024} \quad [\text{V}]$$

N : A/D converter digital output value

V_{OT} (Ideal) = AVSS + 0.5 LSB [V]

V_{FST} (Ideal) = AVRH - 1.5 LSB [V]

V_{NT} : Voltage at a transition of digital output from (N - 1)_H to N_H

(Continued)

(Continued)

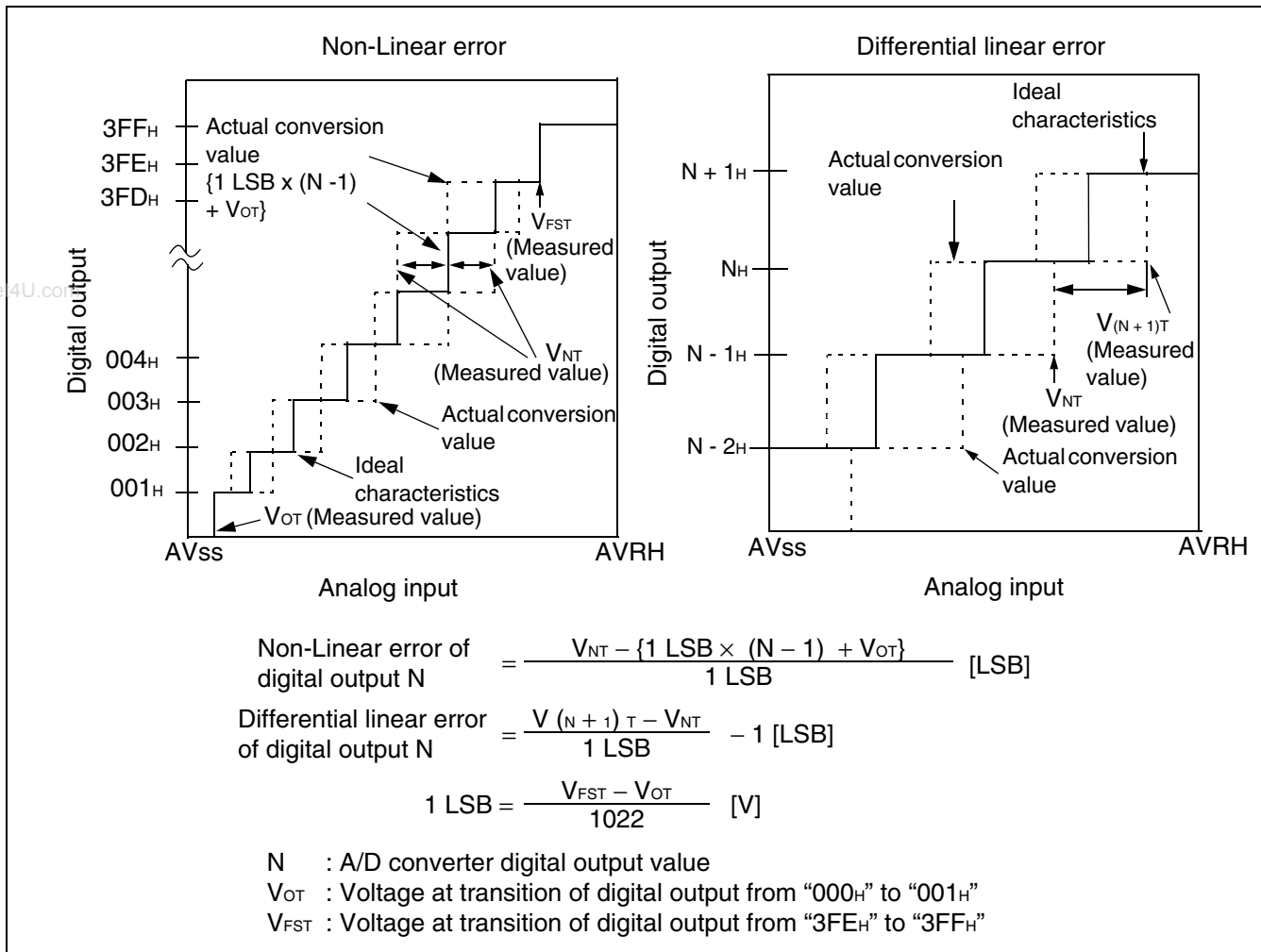

6. Flash Memory Program/Erase Characteristics

Parameter	Conditions	Value			Unit	Remarks
		Min	Typ	Max		
Chip erase time	$T_A = +25\text{ }^\circ\text{C}$ $V_{CC} = 5.0\text{ V}$	—	1	15	s	Excludes pre-programming before erase
Byte (8-bit width) programming time		—	32	3600	μs	Excludes system-level overhead
Erase/program cycle	—	10000	—	—	cycle	
Flash memory data retention time	Average $T_A = +85\text{ }^\circ\text{C}$	20	—	—	year	*

* : This value comes from the technology qualification. (using Arrhenius equation to translate high temperature measurements into normalized value at + 85 °C)

MB90925 Series

■ ORDERING INFORMATION

Part number	Package	Remarks
MB90F927PF-GE1 MB90F927SPF-GE1	100-pin plastic QFP (FPT-100P-M06)	
MB90F927PFV-GE1 MB90F927SPFV-GE1	100-pin plastic LQFP (FPT-100P-M05)	
MB90V925-101 MB90V925-102	299-pin ceramic PGA (PGA-299C-A01)	For evaluation

www.DataSheet4U.com

PACKAGE DIMENSIONS

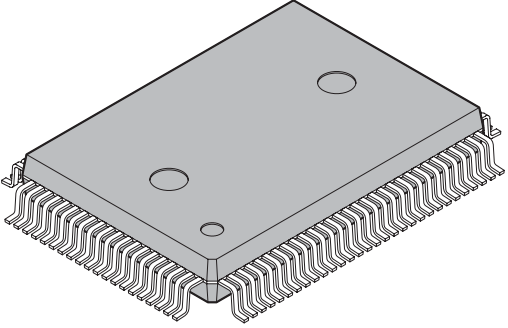
<p>100-pin plastic QFP</p>  <p>(FPT-100P-M06)</p>	Lead pitch	0.65 mm
	Package width × package length	14.00 × 20.00 mm
	Lead shape	Gullwing
	Sealing method	Plastic mold
	Mounting height	3.35 mm MAX
	Code (Reference)	P-QFP100-14×20-0.65

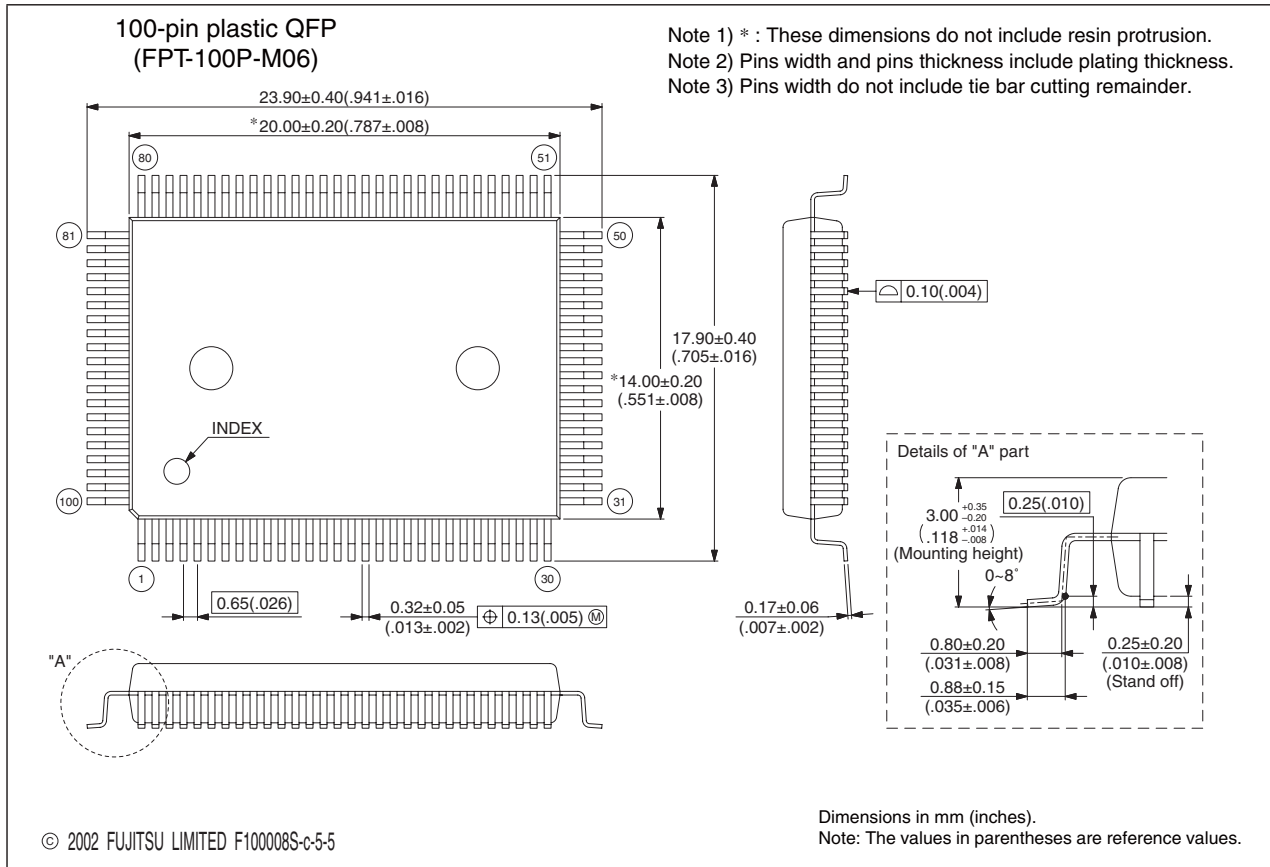

Please confirm the latest Package dimension by following URL.
<http://edevic.fujitsu.com/fj/DATASHEET/ef-ovpkiv.html>

(Continued)

MB90925 Series

(Continued)

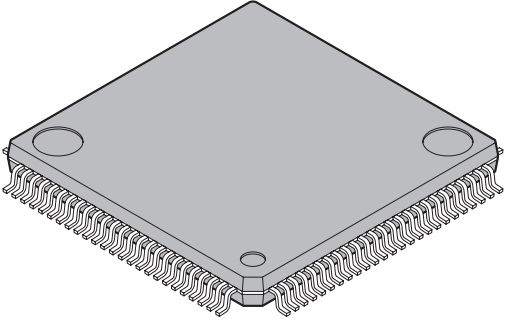
<p style="text-align: center;">100-pin plastic LQFP</p>  <p style="text-align: center;">(FPT-100P-M05)</p>	Lead pitch	0.50 mm
	Package width × package length	14.0 × 14.0 mm
	Lead shape	Gullwing
	Sealing method	Plastic mold
	Mounting height	1.70 mm MAX
	Weight	0.65g
	Code (Reference)	P-LFQFP100-14×14-0.50

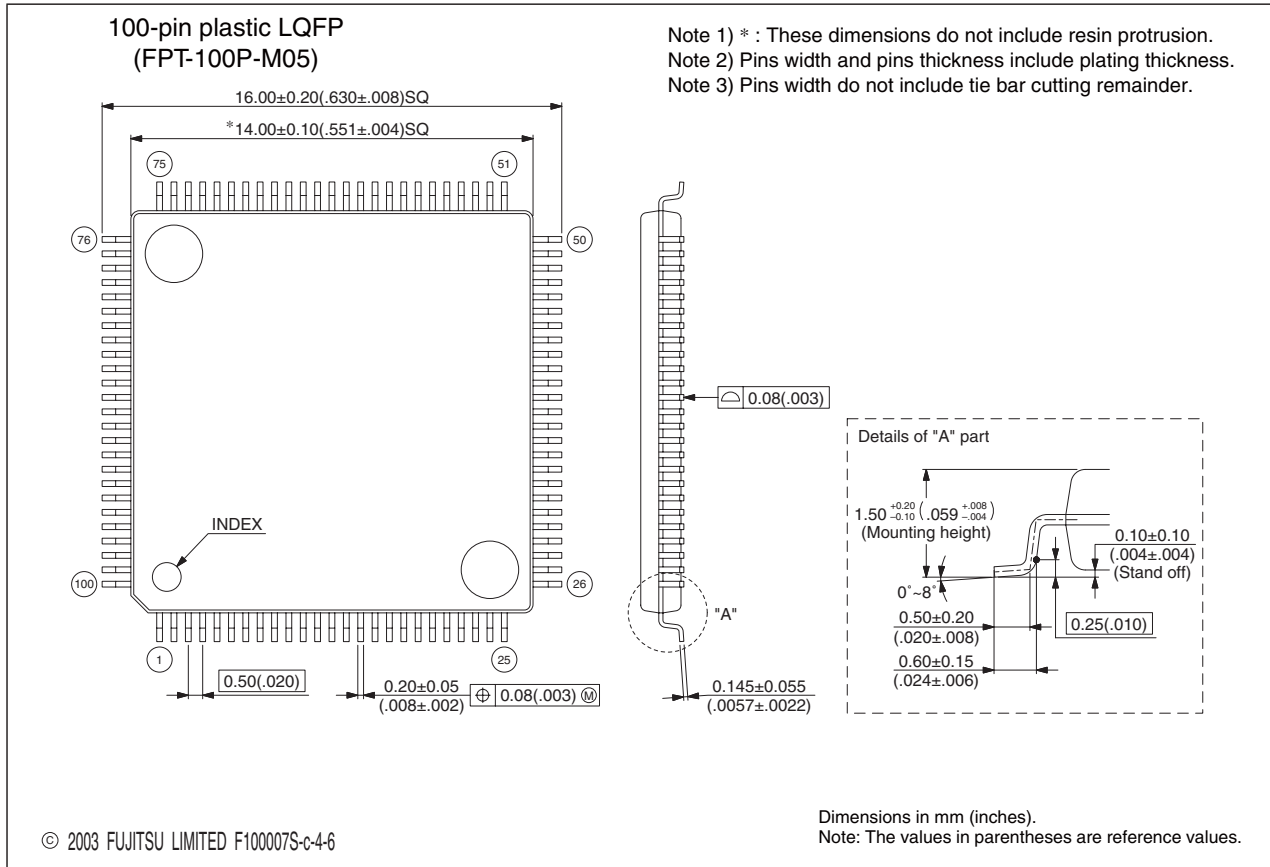

Please confirm the latest Package dimension by following URL.
<http://edevic.fujitsu.com/fj/DATASHEET/ef-ovpkiv.html>

MB90925 Series

The information for microcontroller supports is shown in the following homepage.
<http://www.fujitsu.com/global/services/microelectronics/product/micom/support/index.html>

FUJITSU LIMITED

All Rights Reserved.

The contents of this document are subject to change without notice. Customers are advised to consult with FUJITSU sales representatives before ordering.

The information, such as descriptions of function and application circuit examples, in this document are presented solely for the purpose of reference to show examples of operations and uses of Fujitsu semiconductor device; Fujitsu does not warrant proper operation of the device with respect to use based on such information. When you develop equipment incorporating the device based on such information, you must assume any responsibility arising out of such use of the information. Fujitsu assumes no liability for any damages whatsoever arising out of the use of the information.

Any information in this document, including descriptions of function and schematic diagrams, shall not be construed as license of the use or exercise of any intellectual property right, such as patent right or copyright, or any other right of Fujitsu or any third party or does Fujitsu warrant non-infringement of any third-party's intellectual property right or other right by using such information. Fujitsu assumes no liability for any infringement of the intellectual property rights or other rights of third parties which would result from the use of information contained herein.

The products described in this document are designed, developed and manufactured as contemplated for general use, including without limitation, ordinary industrial use, general office use, personal use, and household use, but are not designed, developed and manufactured as contemplated (1) for use accompanying fatal risks or dangers that, unless extremely high safety is secured, could have a serious effect to the public, and could lead directly to death, personal injury, severe physical damage or other loss (i.e., nuclear reaction control in nuclear facility, aircraft flight control, air traffic control, mass transport control, medical life support system, missile launch control in weapon system), or (2) for use requiring extremely high reliability (i.e., submersible repeater and artificial satellite).

Please note that Fujitsu will not be liable against you and/or any third party for any claims or damages arising in connection with above-mentioned uses of the products.

Any semiconductor devices have an inherent chance of failure. You must protect against injury, damage or loss from such failures by incorporating safety design measures into your facility and equipment such as redundancy, fire protection, and prevention of over-current levels and other abnormal operating conditions.

If any products described in this document represent goods or technologies subject to certain restrictions on export under the Foreign Exchange and Foreign Trade Law of Japan, the prior authorization by Japanese government will be required for export of those products from Japan.

The company names and brand names herein are the trademarks or registered trademarks of their respective owners.

Edited Business Promotion Dept.