

HD74ALVC2G157

2-channel Multiplexer

HITACHI

ADE-205-640A (Z)

Rev. 1
Oct. 2001

Description

The HD74ALVC2G157 has 2-channel multiplexer in a 8 pin package. Low voltage and high speed operation is suitable for the battery powered products (e.g., notebook computers), and the low power consumption extends the battery life.

Features

- The basic gate function is lined up as hitachi uni logic series.
- Supplied on emboss taping for high speed automatic mounting.
- Supply voltage range : 1.2 to 3.6 V
Operating temperature range : -40 to +85°C
- All inputs V_{IH} (Max.) = 3.6 V (@ V_{CC} = 0 V to 3.6 V)
All outputs V_o (Max.) = 3.6 V (@ V_{CC} = 0 V)
- Output current ± 2 mA (@ V_{CC} = 1.2 V)
 ± 4 mA (@ V_{CC} = 1.4 V to 1.6 V)
 ± 6 mA (@ V_{CC} = 1.65 V to 1.95 V)
 ± 18 mA (@ V_{CC} = 2.3 V to 2.7 V)
 ± 24 mA (@ V_{CC} = 3.0 V to 3.6 V)
- Package type

Package type	Package code	Package suffix	Taping code
SSOP-8 pin	TTP-8DB	US	E (3,000 pcs / Reel)

Outline and Article Indication

- HD74ALVC2G157

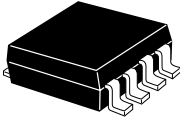

SSOP-8

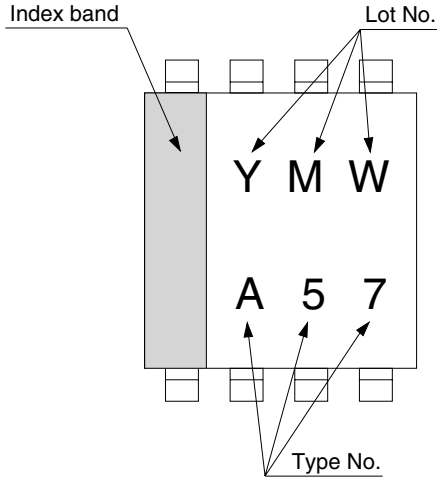

Y : Year code
(the last digit of year)
M : Month code
W : Week code

Function Table

Inputs				Outputs	
$\overline{\text{STB}}$	SEL	A	B	Y	$\overline{\text{Y}}$
H	X	X	X	L	H
L	L	L	X	L	H
L	L	H	X	H	L
L	H	X	L	L	H
L	H	X	H	H	L

H : High level
L : Low level
X : Immaterial

Pin Arrangement

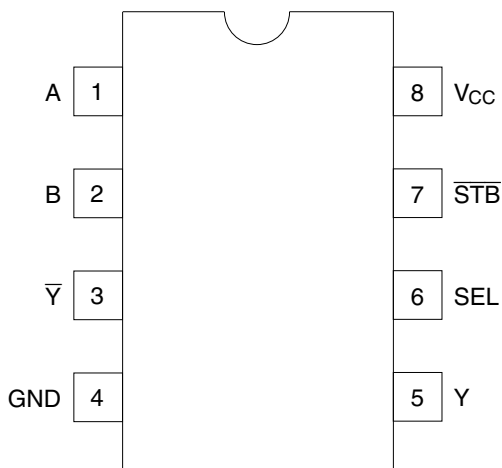

(Top view)

Absolute Maximum Ratings

Item	Symbol	Ratings	Unit	Conditions
Supply voltage range	V_{CC}	-0.5 to 4.6	V	
Input voltage range ¹	V_I	-0.5 to 4.6	V	
Output voltage range ^{1,2}	V_O	-0.5 to $V_{CC}+0.5$ -0.5 to 4.6	V	Output : H or L V_{CC} : OFF
Input clamp current	I_{IK}	-50	mA	$V_I < 0$
Output clamp current	I_{OK}	± 50	mA	$V_O < 0$ or $V_O > V_{CC}$
Continuous output current	I_O	± 50	mA	$V_O = 0$ to V_{CC}
Continuous current through V_{CC} or GND	I_{CC} or I_{GND}	± 100	mA	
Maximum power dissipation at $T_a = 25^\circ\text{C}$ (in still air) ³	P_T	200	mW	
Storage temperature	T_{stg}	-65 to 150	$^\circ\text{C}$	

- Notes: The absolute maximum ratings are values which must not individually be exceeded, and furthermore, no two of which may be realized at the same time.
1. The input and output voltage ratings may be exceeded if the input and output clamp-current ratings are observed.
 2. This value is limited to 4.6 V maximum.
 3. The maximum package power dissipation was calculated using a junction temperature of 150°C.

Recommended Operating Conditions

Item	Symbol	Min	Max	Unit	Conditions
Supply voltage range	V_{CC}	1.2	3.6	V	
Input voltage range	V_I	0	3.6	V	
Output voltage range	V_O	0	V_{CC}	V	
Output current	I_{OH}	—	-2	mA	$V_{CC} = 1.2\text{ V}$
		—	-4		$V_{CC} = 1.4\text{ V}$
		—	-6		$V_{CC} = 1.65\text{ V}$
		—	-18		$V_{CC} = 2.3\text{ V}$
		—	-24		$V_{CC} = 3.0\text{ V}$
	I_{OL}	—	2		$V_{CC} = 1.2\text{ V}$
		—	4		$V_{CC} = 1.4\text{ V}$
		—	6		$V_{CC} = 1.65\text{ V}$
		—	18		$V_{CC} = 2.3\text{ V}$
		—	24		$V_{CC} = 3.0\text{ V}$
Input transition rise or fall rate	$\Delta t / \Delta v$	0	20	ns / V	$V_{CC} = 1.2\text{ to }2.7\text{ V}$
		0	10		$V_{CC} = 3.3\pm 0.3\text{ V}$
Operating free-air temperature	T_a	-40	85	°C	

Note: Unused or floating inputs must be held high or low.

Logic Diagram

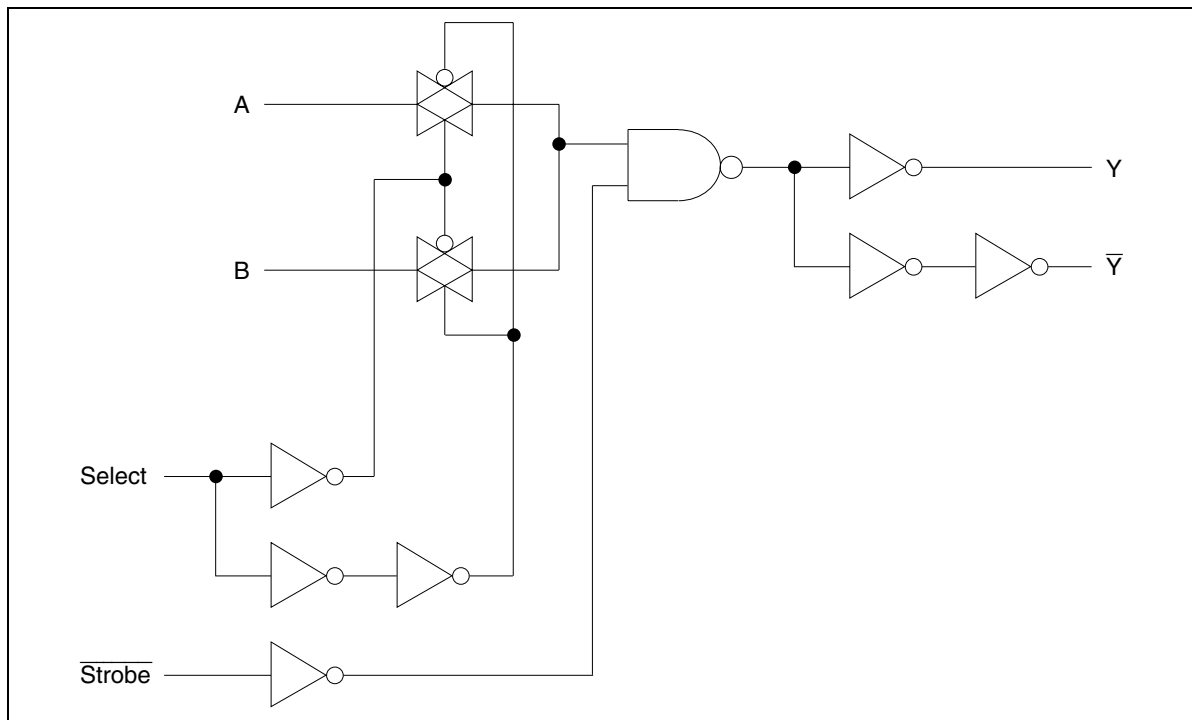

Electrical Characteristics

($T_a = -40$ to 85°C)

Item	Symbol	V_{cc} (V)†	Min	Typ	Max	Unit	Test conditions
Input voltage	V_{IH}	1.2	$V_{cc} \times 0.75$	—	—	V	
		1.4 to 1.6	$V_{cc} \times 0.7$	—	—		
		1.65 to 1.95	$V_{cc} \times 0.7$	—	—		
		2.3 to 2.7	1.7	—	—		
		3.0 to 3.6	2.0	—	—		
	V_{IL}	1.2	—	—	$V_{cc} \times 0.25$		
		1.4 to 1.6	—	—	$V_{cc} \times 0.3$		
		1.65 to 1.95	—	—	$V_{cc} \times 0.3$		
		2.3 to 2.7	—	—	0.7		
		3.0 to 3.6	—	—	0.8		
Output voltage	V_{OH}	Min to Max	$V_{cc} - 0.2$	—	—	V	$I_{OH} = -100 \mu\text{A}$
		1.2	0.9	—	—		$I_{OH} = -2 \text{ mA}$
		1.4	1.1	—	—		$I_{OH} = -4 \text{ mA}$
		1.65	1.2	—	—		$I_{OH} = -6 \text{ mA}$
		2.3	1.7	—	—		$I_{OH} = -18 \text{ mA}$
		3.0	2.2	—	—		$I_{OH} = -24 \text{ mA}$
	V_{OL}	Min to Max	—	—	0.2	$I_{OL} = 100 \mu\text{A}$	
		1.2	—	—	0.3	$I_{OL} = 2 \text{ mA}$	
		1.4	—	—	0.3	$I_{OL} = 4 \text{ mA}$	
		1.65	—	—	0.3	$I_{OL} = 6 \text{ mA}$	
		2.3	—	—	0.55	$I_{OL} = 18 \text{ mA}$	
		3.0	—	—	0.55	$I_{OL} = 24 \text{ mA}$	
		Input current	I_{IN}	3.6	—	—	± 5
Quiescent supply current	I_{CC}	3.6	—	—	10	μA	$V_{IN} = V_{CC}$ or GND, $I_O = 0$
Output leakage current	I_{OFF}	0	—	—	5	μA	V_{IN} or $V_O = 0$ to 3.6 V
Input capacitance	C_{IN}	3.3	—	4.5	—	pF	$V_{IN} = V_{CC}$ or GND

Note: For conditions shown as Min or Max, use the appropriate values under recommended operating conditions.

Switching Characteristics

($T_a = -40$ to 85°C)

- $V_{CC} = 1.2\text{ V}$

Item	Symbol	Min	Typ	Max	Unit	Test conditions	FROM (Input)	TO (Output)
Propagation delay time	t_{PLH}	—	9.5	—	ns	$C_L = 15\text{ pF}$	A or B	Y
		—	10.0	—			SEL	Y
		—	8.0	—			STB	Y

- $V_{CC} = 1.5\pm 0.1\text{ V}$

Item	Symbol	Min	Typ	Max	Unit	Test conditions	FROM (Input)	TO (Output)
Propagation delay time	t_{PLH}	2.0	—	11.0	ns	$C_L = 15\text{ pF}$	A or B	Y
		2.0	—	11.0			SEL	Y
		2.0	—	11.0			STB	Y

- $V_{CC} = 1.8\pm 0.15\text{ V}$

Item	Symbol	Min	Typ	Max	Unit	Test conditions	FROM (Input)	TO (Output)
Propagation delay time	t_{PLH}	1.5	—	9.0	ns	$C_L = 30\text{ pF}$	A or B	Y
		1.5	—	9.0			SEL	Y
		1.5	—	9.0			STB	Y

- $V_{CC} = 2.5\pm 0.2\text{ V}$

Item	Symbol	Min	Typ	Max	Unit	Test conditions	FROM (Input)	TO (Output)
Propagation delay time	t_{PLH}	1.0	—	4.5	ns	$C_L = 30\text{ pF}$	A or B	Y
		1.0	—	4.5			SEL	Y
		1.0	—	4.5			STB	Y

HD74ALVC2G157

- $V_{CC} = 3.3 \pm 0.3 \text{ V}$

Item	Symbol	Min	Typ	Max	Unit	Test conditions	FROM (Input)	TO (Output)
Propagation delay time	t_{PLH}	1.0	—	3.5	ns	$C_L = 30 \text{ pF}$	A or B	Y
		1.0	—	3.5			SEL	Y
		1.0	—	3.5			STB	Y

Operating Characteristics

($T_a = 25^\circ\text{C}$)

Item	Symbol	V_{CC} (V)	Min	Typ	Max	Unit	Test conditions
Power dissipation capacitance	C_{PD}	1.5	—	20.0	—	pF	$f = 10 \text{ MHz}$
		1.8	—	20.0	—		
		2.5	—	26.5	—		
		3.3	—	29.5	—		

Test Circuit

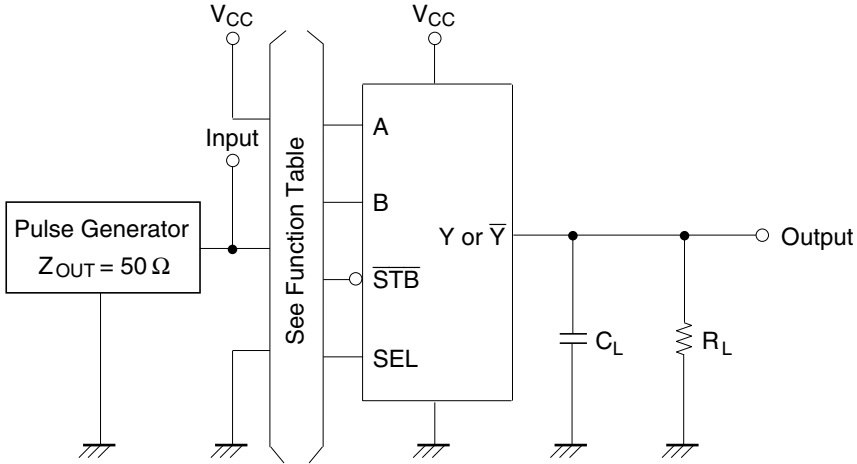

Symbol	$V_{CC} = 1.2 \text{ V},$ $1.5 \pm 0.1 \text{ V}$	$V_{CC} = 1.8 \pm 0.15 \text{ V}$	$V_{CC} = 2.5 \pm 0.2 \text{ V},$ $3.3 \pm 0.3 \text{ V}$
R_L	2.0 k Ω	1.0 k Ω	500 Ω
C_L	15 pF	30 pF	30 pF

Note: C_L includes probe and jig capacitance.

Waveforms

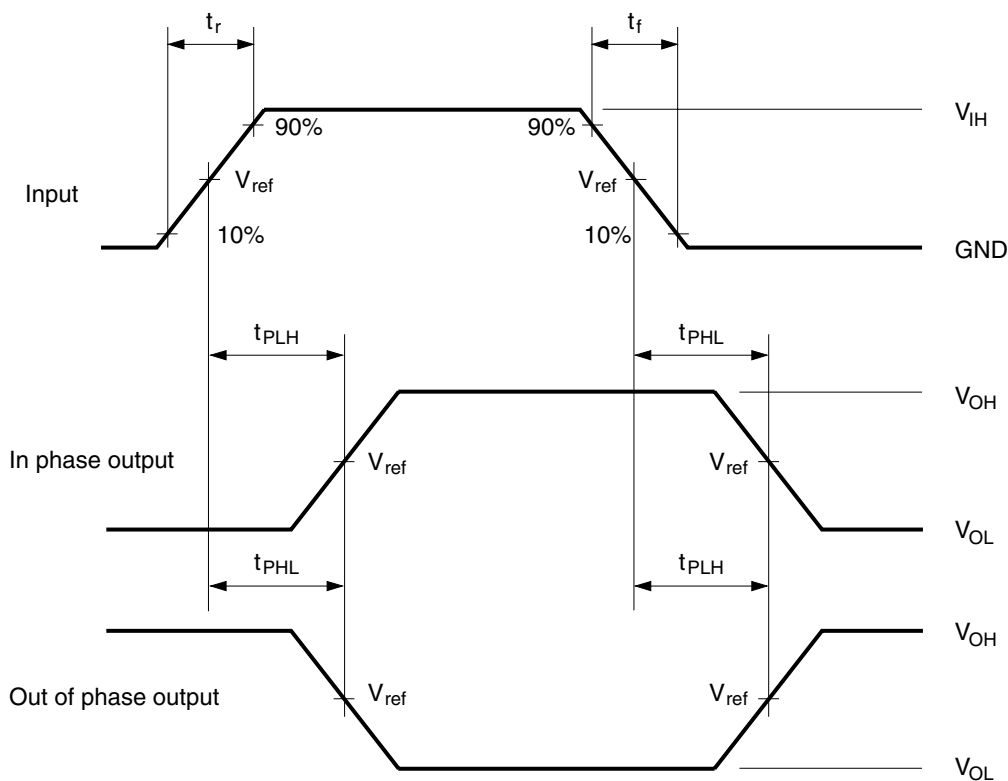

Symbol	$V_{CC} = 1.2\text{ V},$ $1.5 \pm 0.1\text{ V},$ $1.8 \pm 0.15\text{ V}$	$V_{CC} = 2.5 \pm 0.2\text{ V}$	$V_{CC} = 3.3 \pm 0.3\text{ V}$
t_r / t_f	2.0 ns	2.5 ns	2.5 ns
V_{IH}	V_{CC}	V_{CC}	2.7 V
V_{ref}	50%	50%	1.5 V

Note: Input waveform : PRR = 10 MHz, duty cycle 50%

Package Dimensions

As of July, 2001
Unit: mm

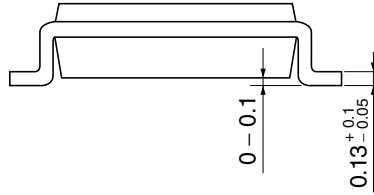
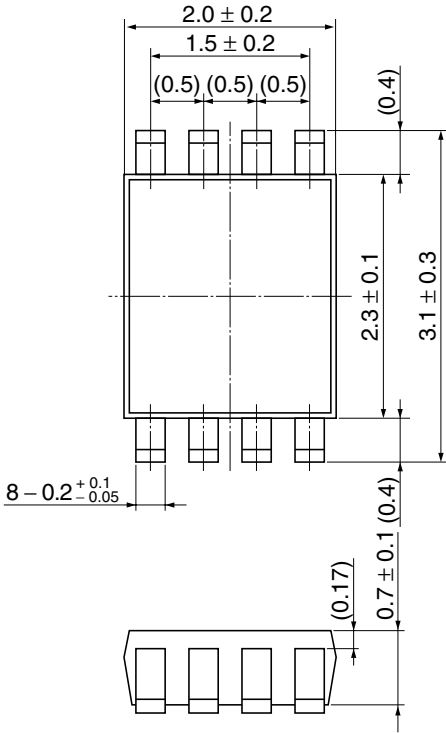

Hitachi Code	TTP-8DB
JEDEC	—
JEITA	—
Mass (reference value)	0.010 g

Disclaimer

1. Hitachi neither warrants nor grants licenses of any rights of Hitachi's or any third party's patent, copyright, trademark, or other intellectual property rights for information contained in this document. Hitachi bears no responsibility for problems that may arise with third party's rights, including intellectual property rights, in connection with use of the information contained in this document.
2. Products and product specifications may be subject to change without notice. Confirm that you have received the latest product standards or specifications before final design, purchase or use.
3. Hitachi makes every attempt to ensure that its products are of high quality and reliability. However, contact Hitachi's sales office before using the product in an application that demands especially high quality and reliability or where its failure or malfunction may directly threaten human life or cause risk of bodily injury, such as aerospace, aeronautics, nuclear power, combustion control, transportation, traffic, safety equipment or medical equipment for life support.
4. Design your application so that the product is used within the ranges guaranteed by Hitachi particularly for maximum rating, operating supply voltage range, heat radiation characteristics, installation conditions and other characteristics. Hitachi bears no responsibility for failure or damage when used beyond the guaranteed ranges. Even within the guaranteed ranges, consider normally foreseeable failure rates or failure modes in semiconductor devices and employ systemic measures such as fail-safes, so that the equipment incorporating Hitachi product does not cause bodily injury, fire or other consequential damage due to operation of the Hitachi product.
5. This product is not designed to be radiation resistant.
6. No one is permitted to reproduce or duplicate, in any form, the whole or part of this document without written approval from Hitachi.
7. Contact Hitachi's sales office for any questions regarding this document or Hitachi semiconductor products.

Sales Offices

HITACHI

Hitachi, Ltd.

Semiconductor & Integrated Circuits
Nippon Bldg., 2-6-2, Ohte-machi, Chiyoda-ku, Tokyo 100-0004, Japan
Tel: (03) 3270-2111 Fax: (03) 3270-5109

URL <http://www.hitachisemiconductor.com/>

For further information write to:

Hitachi Semiconductor (America) Inc.
179 East Tasman Drive
San Jose, CA 95134
Tel: <1> (408) 433-1990
Fax: <1> (408) 433-0223

Hitachi Europe Ltd.
Electronic Components Group
Whitebrook Park
Lower Cookham Road
Maidenhead
Berkshire SL6 8YA, United Kingdom
Tel: <44> (1628) 585000
Fax: <44> (1628) 585200

Hitachi Europe GmbH
Electronic Components Group
Dornacher Straße 3
D-85622 Feldkirchen
Postfach 201, D-85619 Feldkirchen
Germany
Tel: <49> (89) 9 9180-0
Fax: <49> (89) 9 29 30 00

Hitachi Asia Ltd.
Hitachi Tower
16 Collyer Quay #20-00
Singapore 049318
Tel: <65>-538-6533/538-8577
Fax: <65>-538-6933/538-3877
URL: <http://semiconductor.hitachi.com.sg>

Hitachi Asia Ltd.
(Taipei Branch Office)
4/F, No. 167, Tun Hwa North Road
Hung-Kuo Building
Taipei (105), Taiwan
Tel: <886>-(2)-2718-3666
Fax: <886>-(2)-2718-8180
Telex: 23222 HAS-TP
URL: <http://www.hitachi.com.tw>

Hitachi Asia (Hong Kong) Ltd.
Group III (Electronic Components)
7/F., North Tower
World Finance Centre,
Harbour City, Canton Road
Tsim Sha Tsui, Kowloon Hong Kong
Tel: <852>-(2)-735-9218
Fax: <852>-(2)-730-0281
URL: <http://semiconductor.hitachi.com.hk>

Copyright © Hitachi, Ltd., 2001. All rights reserved. Printed in Japan.
Colophon 5.0