

1. PART NO. EXPRESSION :

L 1 M - 1 N 0 S - 1 0
 (a) (b) (c) (d)

- (a) Series and Dimension code
- (b) Inductance code : 1N0 = 1.0nH
- (c) Inductance tolerance : S = $\pm 0.3nH$, J = $\pm 5\%$, K = $\pm 10\%$
- (d) 10 : RoHS Compliant

2. CONFIGURATION & DIMENSIONS :

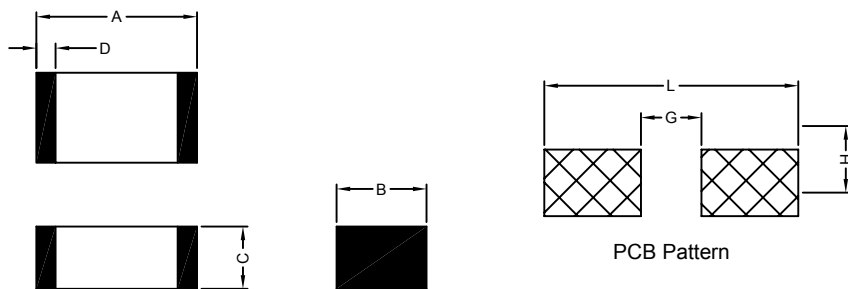

Unit:m/m

A	B	C	D	G	H	L
1.00 \pm 0.10	0.50 \pm 0.10	0.50 \pm 0.10	0.25 \pm 0.10	0.40 Ref.	0.55 Ref.	1.50 Ref.

3. MATERIALS :

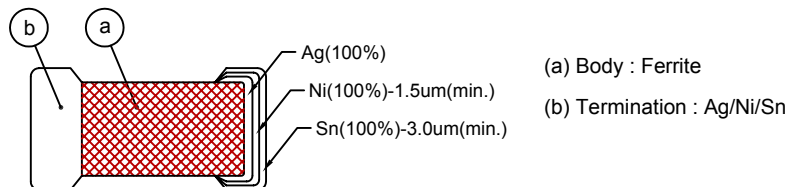

4. GENERAL SPECIFICATION :

- a) Storage temp. : -40° C to +105° C
- b) Operating temp. : -40° C to +105° C (include self-temp. rise)



RoHS Compliant

NOTE : Specifications subject to change without notice. Please check our website for latest information.

10.11.2011



SUPERWORLD ELECTRONICS (S) PTE LTD

5. ELECTRICAL CHARACTERISTICS :

Part Number	Inductance (nH)	Test Frequency (MHz)	Q Min.	DC Resistance (Ω) Min. Max.	SRF (MHz) Min.	Rated Current (mA) Max.
L1M-1N0S-10	1.0	100	5	0.10	12000	500
L1M-1N1S-10	1.1	100	5	0.12	11500	500
L1M-1N2S-10	1.2	100	5	0.12	11000	500
L1M-1N3S-10	1.3	100	5	0.15	10000	500
L1M-1N5S-10	1.5	100	6	0.15	9500	500
L1M-1N6S-10	1.6	100	6	0.17	9000	500
L1M-1N8S-10	1.8	100	6	0.17	8500	500
L1M-2N0S-10	2.0	100	6	0.18	8300	500
L1M-2N2S-10	2.2	100	6	0.18	8000	500
L1M-2N4S-10	2.4	100	6	0.20	7800	500
L1M-2N7S-10	2.7	100	6	0.20	7500	500
L1M-3N0S-10	3.0	100	6	0.22	7200	400
L1M-3N3S-10	3.3	100	6	0.22	7000	400
L1M-3N6S-10	3.6	100	6	0.25	6800	400
L1M-3N9S-10	3.9	100	6	0.25	6500	400
L1M-4N3S-10	4.3	100	6	0.28	6300	400
L1M-4N7S-10	4.7	100	6	0.28	6000	400
L1M-5N1S-10	5.1	100	6	0.30	5800	400
L1M-5N6S-10	5.6	100	6	0.30	5700	400
L1M-6N2S-10	6.2	100	6	0.35	5600	400
L1M-6N8□-10	6.8	100	6	0.35	5500	400
L1M-7N5□-10	7.5	100	6	0.38	5000	350
L1M-8N2□-10	8.2	100	6	0.38	5000	350
L1M-9N1□-10	9.1	100	6	0.42	4800	350
L1M-10N□-10	10	100	6	0.42	4700	350
L1M-12N□-10	12	100	6	0.47	4300	350
L1M-15N□-10	15	100	6	0.50	4000	300
L1M-18N□-10	18	100	6	0.60	4000	250
L1M-22N□-10	22	100	6	0.70	3500	200
L1M-27N□-10	27	100	6	0.80	3000	200
L1M-33N□-10	33	100	6	0.90	2500	200
L1M-39N□-10	39	100	6	1.00	2000	200
L1M-47N□-10	47	100	6	1.20	1800	200



RoHS Compliant

NOTE : Specifications subject to change without notice. Please check our website for latest information.

10.11.2011



SUPERWORLD ELECTRONICS (S) PTE LTD

5. ELECTRICAL CHARACTERISTICS :

Part Number	Inductance (nH)	Test Frequency (MHz)	Q Min.	DC Resistance (Ω) Max.	SRF (MHz) Min.	Rated Current (mA) Max.
L1M-56N□-10	56	100	6	1.30	1500	200
L1M-68N□-10	68	100	6	1.50	1400	150
L1M-82N□-10	82	100	6	1.80	1300	150
L1M-R10□-10	100	100	6	2.20	1100	100
L1M-R11□-10	110	100	6	2.70	1100	100
L1M-R12□-10	120	100	6	3.00	1100	100

□ : J = $\pm 5\%$, K = $\pm 10\%$



RoHS Compliant

NOTE : Specifications subject to change without notice. Please check our website for latest information.

10.11.2011



SUPERWORLD ELECTRONICS (S) PTE LTD

6. CHARACTERISTICS CURVES :

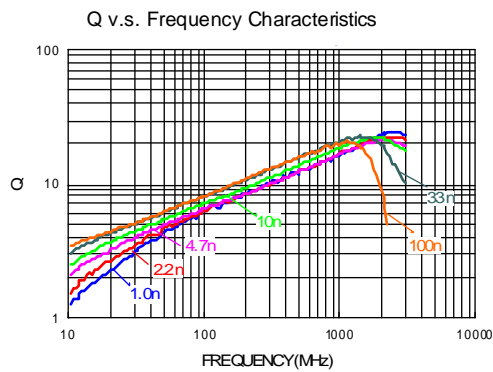
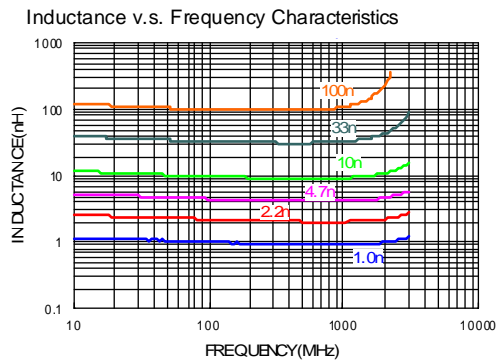

RoHS Compliant



NOTE : Specifications subject to change without notice. Please check our website for latest information.

10.11.2011

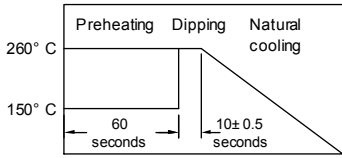
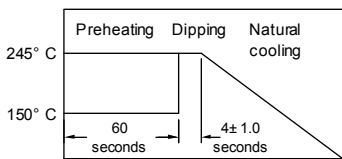

SUPERWORLD ELECTRONICS (S) PTE LTD

7. RELIABILITY & TEST CONDITION :

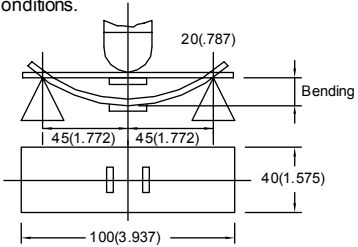
ITEM	PERFORMANCE	TEST CONDITION																								
Electrical Characteristics Test																										
Inductance (Ls)	Refer to standard electrical characteristics list	Agilent E4991																								
Q Factor		Agilent4287																								
DC Resistance		Agilent16192																								
Rated Current		Agilent 4338																								
		DC Power Supply Over Rated Current requirements, there will be some risk																								
Temperature Rise Test	Rated Current < 1A ΔT 20°C Max Rated Current \geq 1A ΔT 40°C Max	1. Applied the allowed DC current. 2. Temperature measured by digital surface thermometer.																								
Solder Heat Resistance	No mechanical damage. Remaining terminal electrode : 75% min. 	Preheat : 150° C, 60sec. Solder : Sn-Cu0.5 Solder Temperature : 260± 5° C Flux for lead free: ROL0 Dip Time : 10± 0.5sec.																								
Solderability	More than 95% of the terminal electrode should be covered with solder. 	Preheat : 150° C, 60sec. Solder : Sn-Cu0.5 Solder Temperature : 245± 5° C Flux for lead free: ROL0 Dip Time : 4± 1sec.																								
Terminal Strength	The terminal electrode & the dielectric must not be damaged by the forces applied on the right conditions. 	For L Series : <table border="1" data-bbox="901 1187 1252 1433"> <thead> <tr> <th>Size</th> <th>Force (Kfg)</th> <th>Time (sec)</th> </tr> </thead> <tbody> <tr> <td>1</td> <td>0.2</td> <td></td> </tr> <tr> <td>2</td> <td>0.5</td> <td></td> </tr> <tr> <td>3</td> <td>0.6</td> <td></td> </tr> <tr> <td>4</td> <td>1.0</td> <td>> 30</td> </tr> <tr> <td>5</td> <td>1.0</td> <td></td> </tr> <tr> <td>6</td> <td>1.0</td> <td></td> </tr> <tr> <td>7</td> <td>1.5</td> <td></td> </tr> </tbody> </table>	Size	Force (Kfg)	Time (sec)	1	0.2		2	0.5		3	0.6		4	1.0	> 30	5	1.0		6	1.0		7	1.5	
Size	Force (Kfg)	Time (sec)																								
1	0.2																									
2	0.5																									
3	0.6																									
4	1.0	> 30																								
5	1.0																									
6	1.0																									
7	1.5																									
Flexture Strength	The terminal electrode & the dielectric must not be damaged by the forces applied on the right conditions. 	Solder a chip on a test substrate, bend the substrate by 2mm (0.079in) and return. The duration of the applied forces shall be 60 (+ 5) Sec.																								



RoHS Compliant

NOTE : Specifications subject to change without notice. Please check our website for latest information.

10.11.2011



SUPERWORLD ELECTRONICS (S) PTE LTD

7. RELIABILITY & TEST CONDITION :

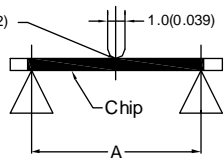
ITEM	PERFORMANCE	TEST CONDITION																	
Bending Strength	<p>The ferrite should not be damaged by forces applied on the right condition.</p> 	<table border="1"> <thead> <tr> <th>Series name</th> <th>mm (inches)</th> <th>P-Kgf</th> </tr> </thead> <tbody> <tr> <td>2</td> <td>0.80 (0.033)</td> <td>0.3</td> </tr> <tr> <td>3</td> <td>1.40 (0.055)</td> <td>1.0</td> </tr> <tr> <td>4</td> <td rowspan="2">2.00 (0.079)</td> <td rowspan="2">2.5</td> </tr> <tr> <td>5</td> </tr> <tr> <td>6</td> <td rowspan="2">2.70 (0.106)</td> <td rowspan="2">2.5</td> </tr> <tr> <td>7</td> </tr> </tbody> </table>	Series name	mm (inches)	P-Kgf	2	0.80 (0.033)	0.3	3	1.40 (0.055)	1.0	4	2.00 (0.079)	2.5	5	6	2.70 (0.106)	2.5	7
Series name	mm (inches)	P-Kgf																	
2	0.80 (0.033)	0.3																	
3	1.40 (0.055)	1.0																	
4	2.00 (0.079)	2.5																	
5																			
6	2.70 (0.106)	2.5																	
7																			
Random Vibration Test	Appearance : Cracking, shipping & any other defects harmful to the characteristics should not be allowed.	Frequency : 10-55-10Hz for 15 min. Amplitude : 1.52mm Directions & times : X, Y, Z directions for 15 min. This cycle shall be performed 12 times in each of three mutually perpendicular directions (Total 9hours).																	
Life testing at High Temperature	Appearance : No damage. Inductance : within $\pm 10\%$ of initial value. Q : within $\pm 20\%$ of initial value.	Temperature : $105 \pm 2^\circ \text{C}$ Applied Current : rated current Duration : 1008 ± 12 hrs Measured at room temperature after placing for 2 to 3hrs.																	
Humidity		Humidity : 90-95% RH. Temperature : $60 \pm 2^\circ \text{C}$ Duration : 504 ± 8 hrs Measured at room temperature after placing for 2 to 3hrs.																	
Thermal Shock	Appearance : No damage. Inductance : within $\pm 10\%$ of initial value. Q : within $\pm 20\%$ of initial value.	Condition for 1 cycle Step1 : $-40 \pm 2^\circ \text{C}$ 30 ± 5 min. Step2 : $+105 \pm 2^\circ \text{C}$ 30 ± 5 min. Number of cycles : 500 Measured at room temperature after placing for 2 to 3hrs.																	
Low temperature storage test	<table border="1"> <thead> <tr> <th>Phase</th> <th>Temperature ($^\circ \text{C}$)</th> <th>Times (min.)</th> </tr> </thead> <tbody> <tr> <td>1</td> <td>$-40 \pm 2^\circ \text{C}$</td> <td>30 ± 5</td> </tr> <tr> <td>2</td> <td>room temp.</td> <td>≤ 0.5</td> </tr> <tr> <td>3</td> <td>$+105 \pm 2^\circ \text{C}$</td> <td>30 ± 5</td> </tr> </tbody> </table> Measured : 500 times	Phase	Temperature ($^\circ \text{C}$)	Times (min.)	1	$-40 \pm 2^\circ \text{C}$	30 ± 5	2	room temp.	≤ 0.5	3	$+105 \pm 2^\circ \text{C}$	30 ± 5	Temperature : $-40 \pm 2^\circ \text{C}$ Duration : 500 ± 8 hrs Measured at room temperature after placing for 2 to 3hrs.					
Phase	Temperature ($^\circ \text{C}$)	Times (min.)																	
1	$-40 \pm 2^\circ \text{C}$	30 ± 5																	
2	room temp.	≤ 0.5																	
3	$+105 \pm 2^\circ \text{C}$	30 ± 5																	
Drop	Drop 10 times on a concrete floor from a height of 75cm.	a. No mechanical damage b. Inductance change: Within $\pm 30\%$.																	

Derating Curve

For the ferrite chip bead which withstanding current over 1.5A, as the operating temperature over 85°C , the derating current information is necessary to consider with. For the detail derating of current, please refer to the Derated Current vs. Operating Temperature curve.

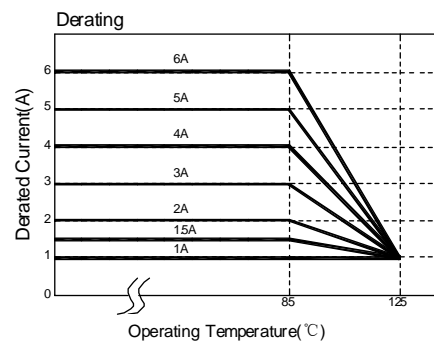

RoHS Compliant

NOTE : Specifications subject to change without notice. Please check our website for latest information.



SUPERWORLD ELECTRONICS (S) PTE LTD

10.11.2011

8. SOLDERING AND MOUNTING :

8-1. Recommended PC Board Pattern

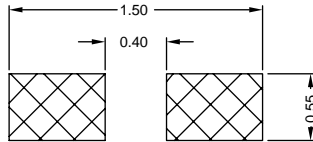

PC board should be designed so that products are not sufficient under mechanical stress as warping the board.
Products shall be positioned in the sideways direction against the mechanical stress to prevent failure.

8-2. Soldering

Mildly activated rosin fluxes are preferred. The minimum amount of solder can lead to damage from the stresses caused by the difference in coefficients of expansion between solder, chip and substrate. The terminations are suitable for re-flow soldering systems. If hand soldering cannot be avoided, the preferred technique is the utilization of hot air soldering tools.
Note.

If Use Wave soldering is there will be some risk.

Re-flow soldering temperatures below 240 degrees, there will be unwitting risk

8-2.1 Lead Free Solder Re-flow :

Recommended temperature profiles for re-flow soldering in Figure 1.

8-2.3 Soldering Iron :

Products attachment with soldering iron is discouraged due to the inherent process control limitations. In the event that a soldering iron must be employed the following precautions are recommended. for Iron Soldering in Figure 2.

Note :

- a) Preheat circuit and products to 150° C.
- b) 350° C tip temperature (max)
- c) Never contact the ceramic with the iron tip
- d) 1.0mm tip diameter (max)
- e) Use a 20 watt soldering iron with tip diameter of 1.0mm
- f) Limit soldering time to 4-5sec.

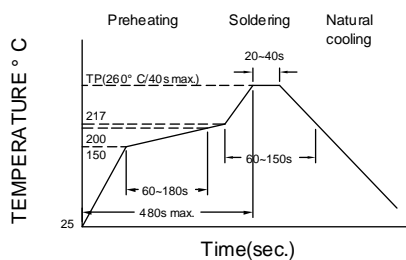

Figure 1. Re-flow Soldering : 3 times max

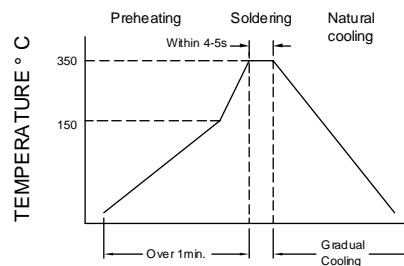

Figure 2. Iron Soldering times: 1 times max

NOTE : Specifications subject to change without notice. Please check our website for latest information.



RoHS Compliant



8-3. Solder Volume

Accordingly increasing the solder volume, the mechanical stress to product is also increased. Exceeding solder volume may cause the failure of mechanical or electrical performance. Solder shall be used not to be exceed as shown in Fig. 4.

Minimum fillet height = soldering thickness + 25% product height

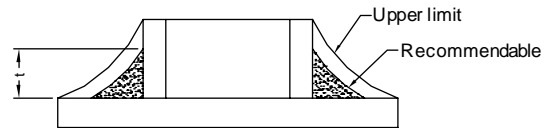

Figure 4



RoHS Compliant

NOTE : Specifications subject to change without notice. Please check our website for latest information.

10.11.2011



SUPERWORLD ELECTRONICS (S) PTE LTD

9. PACKAGING INFORMATION :

9-1. Reel Dimension

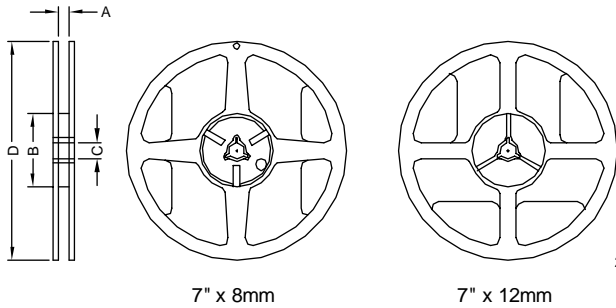

Type	A(mm)	B(mm)	C(mm)	D(mm)
7" x 8mm	9.0±0.5	60.0±2.0	13.5±0.5	178.0±2.0
7" x 12mm	13.5±0.5	60.0±2.0	13.5±0.5	178.0±2.0

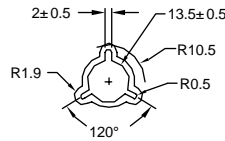

9-2 Tape Dimension / 8mm

Material of taping is paper

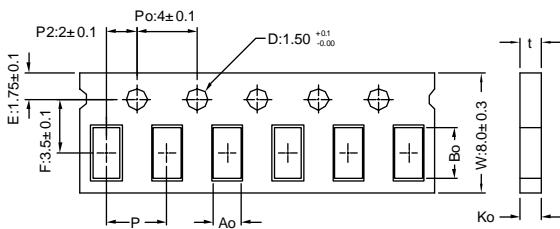

Series	Size	Bo(mm)	Ao(mm)	Ko(mm)	P(mm)	t(mm)	D1(mm)
L	0	0.68±0.05	0.38±0.05	0.50max	2.0±0.05	0.50max	none

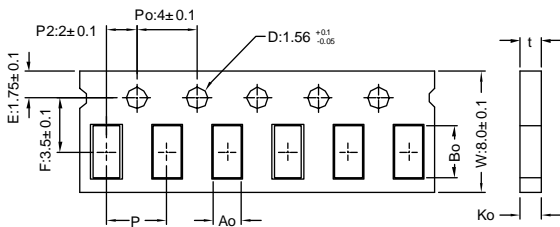

Series	Size	Bo(mm)	Ao(mm)	Ko(mm)	P(mm)	t(mm)	D1(mm)
L	1	1.12±0.03	0.62±0.03	0.60±0.03	2.0±0.1	0.60±0.03	none
	2	1.85±0.05	1.05±0.05	0.95±0.05	4.0±0.1	0.95±0.05	none
	3(09)	2.30±0.05	1.50±0.05	0.95±0.05	4.0±0.1	0.95±0.05	none

Material of taping is plastic

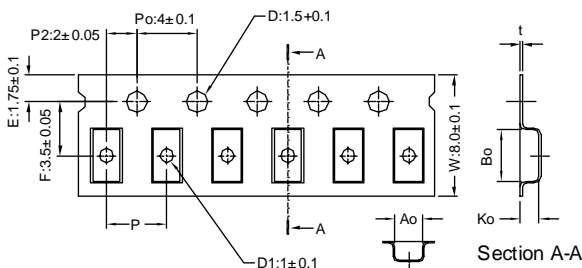

Series	Size	Bo(mm)	Ao(mm)	Ko(mm)	P(mm)	t(mm)	D1(mm)
L	2	1.95±0.10	1.05±0.10	1.05±0.10	4.0±0.1	0.23±0.05	none
	3(09)	2.25±0.10	1.42±0.10	1.04±0.10	4.0±0.1	0.22±0.05	1.0±0.10
	3(12)	2.35±0.10	1.50±0.10	1.45±0.10	4.0±0.1	0.22±0.05	1.0±0.10
	4(11)	3.50±0.10	1.88±0.10	1.27±0.10	4.0±0.1	0.22±0.05	1.0±0.10
	5	3.42±0.10	2.77±0.10	1.55±0.10	4.0±0.1	0.22±0.05	1.0±0.10
	4(09)	3.40±0.10	1.77±0.10	1.04±0.10	4.0±0.1	0.22±0.05	1.0±0.10



RoHS Compliant

NOTE : Specifications subject to change without notice. Please check our website for latest information.

10.11.2011

9-2.1 Tape Dimension / 12mm

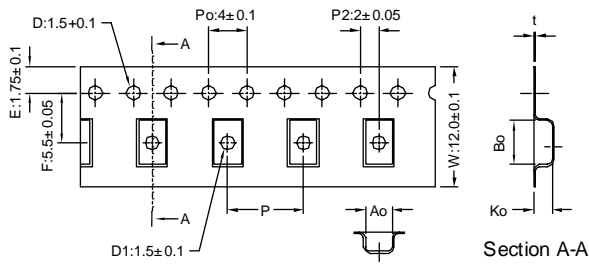

Series	Size	Bo(mm)	Ao(mm)	Ko(mm)	P(mm)	t(mm)	D1(mm)
L	6	4.95±0.1	1.93±0.1	1.93±0.1	4.0±0.1	0.24±0.05	1.5±0.1
	7	4.95±0.1	3.66±0.1	1.85±0.1	8.0±0.1	0.24±0.05	1.5±0.1

9-3. Packaging Quantity

Chip Size	7	6	5	4(11)	4(09)	3(12)	3(09)	2	1	0
Chip / Reel	1000	2000	2500	3000	3000	2000	4000	4000	10000	15000
Inner Box	4000	8000	12500	15000	15000	10000	20000	20000	50000	75000
Middle Box	20000	40000	62500	75000	75000	50000	100000	100000	250000	375000
Carton	40000	80000	125000	150000	150000	100000	200000	200000	500000	750000
Bulk (Bags)	12000	20000	30000	50000	50000	100000	150000	200000	300000	-

9-4. Tearing Off Force

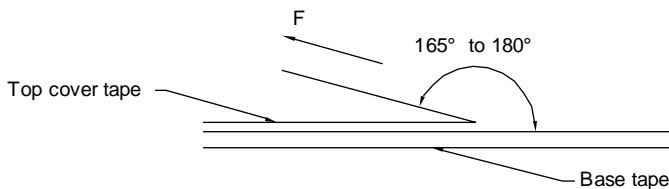

The force for tearing off cover tape is 15 to 60 grams in the arrow direction under the following conditions.

Room Temp. (° C)	Room Humidity (%)	Room atm (hPa)	Tearing Speed (mm/min)
5~35	45~85	860~1060	300

Application Notice

1. Storage Conditions :

To maintain the solderability of terminal electrodes :

- Temperature and humidity conditions : -10~ 40° C and 30~70% RH.
- Recommended products should be used within 6 months from the time of delivery.
- The packaging material should be kept where no chlorine or sulfur exists in the air.

2. Transportation :

- Products should be handled with care to avoid damage or contamination from perspiration and skin oils.
- The use of tweezers or vacuum pick up is strongly recommended for individual components.
- Bulk handling should ensure that abrasion and mechanical shock are minimized.



RoHS Compliant

NOTE : Specifications subject to change without notice. Please check our website for latest information.

