

# USER MANUAL

## Hardware Part

### **SAA7709H/N1B**

#### **Car Radio Digital Signal Processor**

Product Development CarDSP, Mainstream Consumer Systems Nijmegen, The Netherlands.

Version nr. : 4.0

Author : G. Laarhoven

Status : Accepted

Date : January 8, 2002

Report nr. : RNB-C/3272/2002I-0005

---

## REVISION HISTORY

---

Manual version	Date	Remarks
1.0	March 31, 2000	N101A initial version
2.0	August 11, 2000	N102B initial version
3.0	October 30, 2000	N103B initial version
		<ul style="list-style-type: none"><li>• Radio features adapted</li><li>• RDS description adapted</li></ul>
4.0	January 4, 2002	N1B final version
		<ul style="list-style-type: none"><li>• Fig. 8.15 : changed. Resistor R16/R18 is added</li><li>• Fig. 8.23 : changed. Resistor R5 is added</li><li>• Table 8.2 : Timing (unit) RDS changed</li><li>• Chapter 8.8: Chapter "Interface with tuner TEA6840 is added</li></ul>

## **Summary.**

The purpose of this manual is to give all hardware application information of the SAA7709H, being a Car Radio Digital Signal Processor (CDSP), needed to make a hardware application. Also the audio and radio features are described.

The audio and software part of the SAA7709H/N103B is described in a other document named "Software Audio and Radio part SAA7709H/N103B".

Before reading this report it is necessary to read first the data sheet of the SAA7709H.

In this manual all the pins are described with additional information on the input- and output circuits. The blockdiagram is given and all functions are explained. All necessary coefficient settings and tables for several selections are given. The application diagram is explained in detail.

# Table of Contents

<b>1</b>	<b>INTRODUCTION.</b>	<b>7</b>
<b>2.</b>	<b>GENERAL DESCRIPTION.</b>	<b>8</b>
<b>3</b>	<b>HARDWARE/SOFTWARE FEATURES.</b>	<b>8</b>
3.1	Hardware features	8
3.2	Software features	9
<b>4</b>	<b>QUICK REFERENCE SPECIFICATION.</b>	<b>9</b>
4.1	FM reception	9
4.2	AM reception	10
4.3	Analogue tape input	10
4.4	Analogue CD input	10
4.5	RDS reception	10
4.6	CD I2S / SPDIF input	11
4.7	Audio output performance	11
4.8	Audio processing	11
4.8.1	Volume/balance/fader/tone/loudness/dynamic bass boost control	11
4.8.2	Equalisation	11
<b>5</b>	<b>BLOCK DIAGRAMS.</b>	<b>12</b>
5.1	Total block diagram	12
5.2	CDSP Block diagram.	13
<b>6</b>	<b>PINNING DIAGRAM.</b>	<b>14</b>
6.1	Pin description.	15
<b>7</b>	<b>FUNCTIONAL DESCRIPTION OF THE CDSP MODES AND FUNCTIONS.</b>	<b>18</b>
7.1	Audio processing	18
7.2	FM mode	19
7.4	General purpose tone generator	21
7.5	Tone sequencer	21

7.6	Noise generator	22
7.7	MSS function	22
7.8	Radio Data System (RDS) function	22
7.9	Second processor extension function	22
<b>8</b>	<b>HARDWARE APPLICATION OF THE CDSP</b>	<b>23</b>
8.1	Audio processing in DSP	23
8.1.1	Analogue outputs (pin 8, 9, 13 and 15)	23
8.1.2.	Internal reference voltage sources VREFDA (pin 12) and VREFAD (pin 77)	24
8.1.2.3	Ref. voltages for the AD convertors VDACP (pin 75) and VDACN (pin 76)	25
8.1.3	Power on/off mute	26
8.1.4	DSP Reset (pin 42)	28
8.2	AM / FM signal quality processing	30
8.3	FM mode	31
8.3.1	FM input pins	31
8.3.2	FM input sensitivity selection	32
8.3.3	FM IAC	34
8.4	AM, AUX, Tape, Phone, NAV and CD_A inputs	40
8.4.1	AM inputs	42
8.4.1.1	AM inputs for AM-mono mode and AM-stereo mode with external decoder	42
8.4.2	Tape / AUX input	44
8.4.3	Analogue CD input	45
8.5	Phone and Navigation inputs	47
8.6	CD-digital inputs (I2S or SPDIF)	52
8.6.1	General	52
8.6.2	I2S input	52
8.6.3	SPDIF input	53
8.7	Radio Data System (RDS) function	53
8.7.1	General description	53
8.7.3	Direct RDS Inputs/outputs in DAVD mode (dac0=1, dac1=1, RDS decoder bypass mode)	56
8.7.4	Direct RDS Timing of Clock and Data signals in DAVD mode (dac0=1, dac1=1, RDS decoder bypass mode)	56
8.7.5	Buffering of RDS data	57
8.7.6	Buffer interface	57
8.7.3	Fast RDS detection with the rds-band signal level detector	58
8.7.4	Bitslip	60
8.7.5	RDS/RBDS decoder	61
8.7.6	RDS/RBDS block detection	62
8.7.7	Error detection and correction	62
8.7.8	Synchronization	63
8.7.9	Flywheel for synchronization hold	63
8.7.10	Bit slip correction	63
8.7.11	Data processing control	63
8.7.12	Restart of synchronization mode:	64
8.7.13	Error correction control mode for synchronization:	64
8.7.14	RBDS processing mode:	64
8.7.15	Data available control modes:	65
8.7.16	Data output of RDS/RBDS information	65

<b>8.8</b>	<b>Interface with Tuner TEA6840 (NICE)</b>	<b>66</b>
<b>8.9</b>	<b>I2C interface</b>	<b>68</b>
<b>8.10</b>	<b>Second processor extension function</b>	<b>69</b>
<b>8.11</b>	<b>Digital subwoofer and center output</b>	<b>69</b>
<b>8.12</b>	<b>External DAC output (subwoofer)</b>	<b>69</b>
<b>8.13</b>	<b>X-tal oscillator circuit</b>	<b>70</b>
<b>8.13</b>	<b>EMC SAA7709H application</b>	<b>72</b>
<b>8.14</b>	<b>Changing the clock frequency of the DSP</b>	<b>73</b>
<b>8.14.1</b>	<b>Procedure for increasing the clock frequency of the DSP</b>	<b>73</b>
<b>APPENDIX 1</b>	<b>: APPLICATION DIAGRAM</b>	<b>74</b>

## **1 Introduction.**

Digital techniques have been widely accepted in the audio world including in the Car Radio. The CD was the first example, nowadays the digitisation of the Car Radio is a logical continuation of this trend.

Furthermore, in the Car Radio world there is a growing demand not only for a good radio perception but also for a better sound quality. People want the sound of their living room in their vehicle. This led not only to the digitisation of analogue designs of the Car Radio, but also to the incorporation of a customised DSP on board of a Car Radio I.C., delivering many possibilities for sound quality improvement.

## 2. General description.

The CDSP-chip performs all the signal functions in front of the power amplifiers and behind the AM and FM\_MPX demodulation of a car radio or the tape input. These functions are: interference absorption, stereo decoding, RDS demodulation and decoding, FM and AM weak signal processing (soft-mute, sliding stereo, etc.), Dolby-B tape noise reduction and the audio controls (volume, balance, fader and tone). Some functions have been implemented in hardware (stereo decoder, RDS decoding and IAC for FM\_MPX) and are not freely programmable. Digital audio signals from external sources with the Philips I<sup>2</sup>S and the LSB 16, 18, 20 and 24 bit justified format or SPDIF format up to Fs = 48 kHz are accepted. There are four independent analogue output channels.

The SAA7709H/N103B is the final version. All audio and radio software features are in the N103 romcode available. The hardware of the IC between the N102B and N103B are the same.

The DSP contains a basic program which enables a set with AM/FM reception, compressor function for all audio modes on the primary channel (channel 1) and fader/balance control. A hardware 5 band per channel parametric equalizer is also implemented. With some restrictions also 2 different stereo channels can be processed.

## 3 Hardware/software features.

### 3.1 Hardware features

- 1 Bit stream 1st order Sigma-Delta A/D converter with anti aliasing broadband input filter
- 4 Bit stream 3rd order Sigma-Delta A/D converters with anti aliasing broadband input filter
- 4 Bitstream D/A converters with 128-fold oversampling and noise shaping
- 4 channel 5 band I<sup>2</sup>C controlled parametric equalizer
- Integrated semi-digital filter, no external post filter required for D/A.
- A stereo I<sup>2</sup>S output with 256 Fs clock for connection to an external DA converter.
- Limited dual media support, allowing limited separate front-seat and rear-seat signal sources and separate control.
- Digital FM stereo decoder.
- Digital FM interference Suppression.
- RDS demodulation decoding via separate ADC, with buffered output option on the demodulator and decoder I<sup>2</sup>C accessible.
- Two mono CMRR or differential input high performance stages for voice signals from Phone and Navigation inputs via 3rd order Sigma-Delta A/D converter.
- Four switchable stereo CMRR or differential input stages. (CD-walkman, CD-changer etc.)
- Analogue single ended tape input
- A 5120 X 32 DSP Program ROM, a 1024 X 24 Data Ram and a 640 X 12 Coefficient RAM.
- Separate AM-left and AM-right inputs in case of use of *external* AM stereo decoder.
- One digital input: I<sup>2</sup>S or LSB justified format.
- Two digital inputs: SPDIF format at Fs = 48 kHz maximum.
- Audio output short circuit protected
- I<sup>2</sup>C bus controlled (including fast mode)



- A Phase Lock Loop derives the internal clock for the DSP from one common fundamental crystal oscillator
- A Phase Lock Loop derives the internal clock for the DAC and other parts of the IC from a digital input Word Select
- Combined AM/FM level input
- Relative high pin compatibility with SAA7704, SAA7705, SAA7706, SAA7708 (incidental minor replacements needed)
- Low number of external components required
- -40 to +85 °C operating temperature range
- Easy applicable

### 3.2 Software features

- FM de-matrixing
- AM brick wall filter
- Baseband Audio processing (balance/fader/volume)
- Soft Audio Mute
- Large volume jumps e-power interpolated for smooth volume steps
- General Purpose Tone Generator

## 4 Quick reference specification.

Important: This overview shows the best specification which can be obtained with an 'ideal' receiver in combination with the SAA7709H. However the specification points 4.1 and 4.2 will be limited by the front-end receiver and not by the SAA7709H.

### 4.1 FM reception

Frequency response(+/-1 dB)	20 Hz - 17 kHz
S/N (mono, 1KHz, 22.5 kHz dev.) (deemphasis 50 µs)	> 69 dB ; typical 72 dB
S/N (stereo, 1 kHz, 22.5 kHz dev.) (deemphasis 50 µs)	> 60 dB ; typical 63 dB
Max. deviation (at THD < 1%) at 1 kHz	> 120 kHz
Mono distortion, 1 kHz at 75 kHz deviation	< 0.2 %
at 22.5 kHz deviation	< 0.1 %
Stereo distortion, 1KHz, 1 channel at 22.5 kHz deviation	< 0.2 %
Stereo channel separation, 1 kHz	> 40 dB ; typical 45 dB

## 4.2 AM reception

Frequency response with tuner	20 Hz - 2 kHz
Frequency response (+/-1 dB) with DSP software brickwall filter (without tuner)	20 Hz - 4.5 kHz
Frequency response (+/-1 dB) without brickwall filter (without tuner)	20 Hz - 15 kHz
S/N at 1 kHz, 30 % AM	> 70 dB ; typical 75 dB
Distortion, 400 Hz, BW 5 kHz	
80 % AM	< 0.2 %
30 % AM	< 0.1 %

## 4.3 Analogue tape input

Frequency response (+/-3 dB)	20 Hz - 18 kHz
Typ. S/N at 1 kHz, 0 ref. dB	84 dB
Typ. THD+N, 1 kHz (0.55 Vrms)	-85 dB
Typ. channel separation, 1 kHz	65 dB

RDS traffic information reception from radio signals in this mode is possible; the decoder is still operating

## 4.4 Analogue CD input

Frequency response (+/-3 dB)	20 Hz - 18 kHz
Typ. S/N at 1 kHz, 0 dB ref.	84 dB
Typ. THD+N, 1 kHz (0.5 Vrms)	-85 dB
Typ. channel separation, 1 kHz	65 dB

RDS traffic information reception from radio signals in this mode is possible; the decoder is still operating

## 4.5 RDS reception

Min. nearby selectivity (neighbour ch at 200 kHz)	61 dB
Min. pilot attenuation	50 dB

## 4.6 CD I2S / SPDIF input

The performance of these input signals is actually limited by the DAC output, as described in chapter 4.7.

The digital CD input can be used as an alternative input for the analogue CD.

RDS traffic information reception from radio signals in this mode is possible; the decoder is still operating

## 4.7 Audio output performance

Typ. output level	1 Vrms
Bandwidth (fs=44.1 kHz, -3dB)	20 Hz - 22 kHz
Typ. S/N	105 dBA
Typ. output noise	3 $\mu$ V ; A-weighted
Typ. THD+N, 1 kHz, 0 dB	-90 dB
Typ. Dynamic Range, 1 kHz (-60 dB)	97 dBA

## 4.8 Audio processing

### 4.8.1 Volume/balance/fader/tone/loudness/dynamic bass boost control

(figures count for default coefficient set)

Volume control range	-66 dB --> +24 dB
Balance attenuation range (Left/Right)	0 dB --> -66 dB
Fader attenuation range (Front/Rear)	0 dB --> -66 dB

### 4.8.2 Equalisation

Number of bands	20 bands
Filter order	2nd order BP
Centre frequency	20 Hz --> 18 kHz
Gain control range	-30 dB --> +12 dB
Quality factor	0.01 --> 100

## 5 Block diagrams.

### 5.1 Total block diagram

The total block diagram indicates a possible application in which the CDSP can be used.

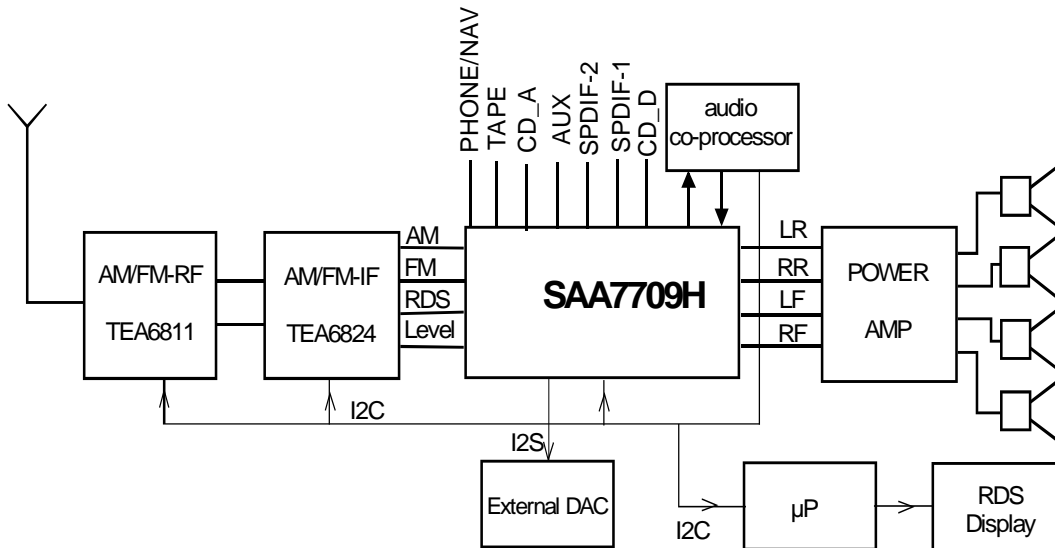

Fig 5.1 Total block diagram

## 5.2 CDSP Block diagram.

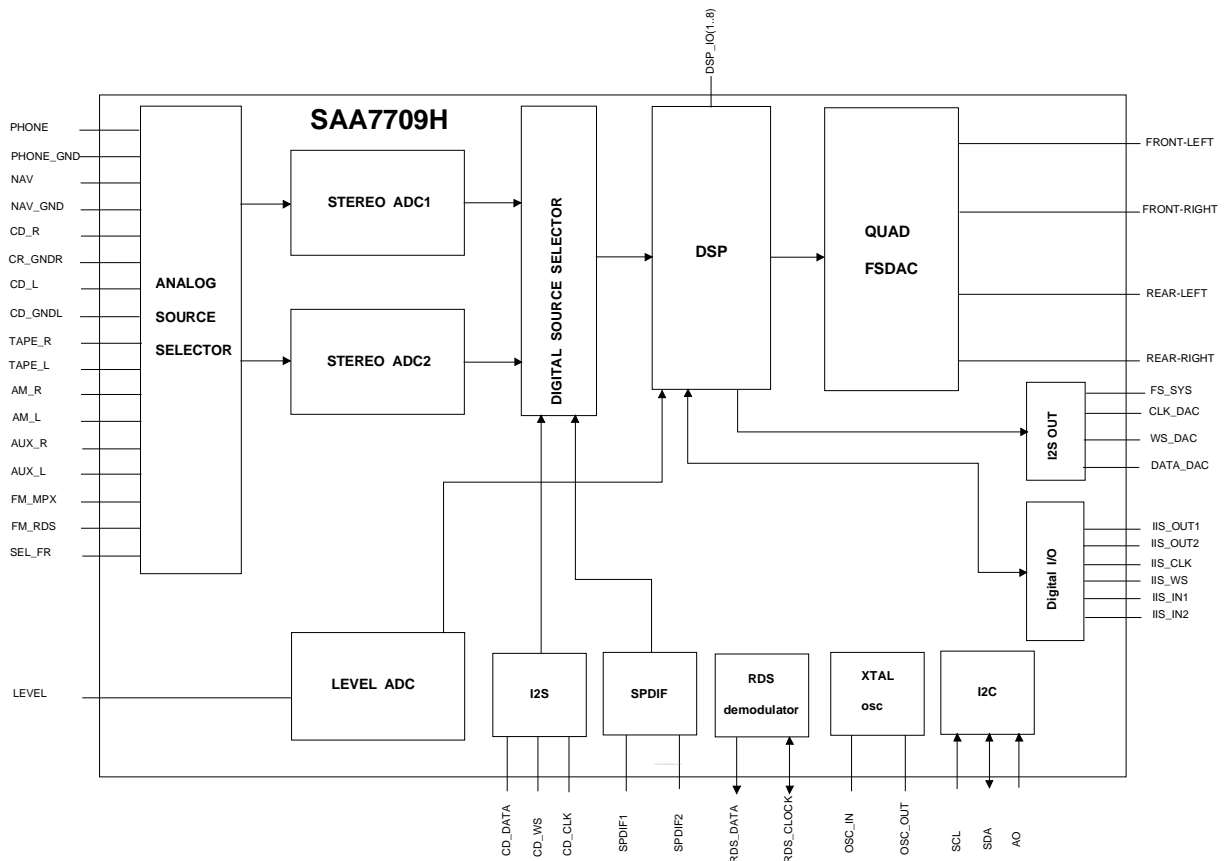

Fig 5.2 Block diagram CDSP

## 6 Pinning diagram.

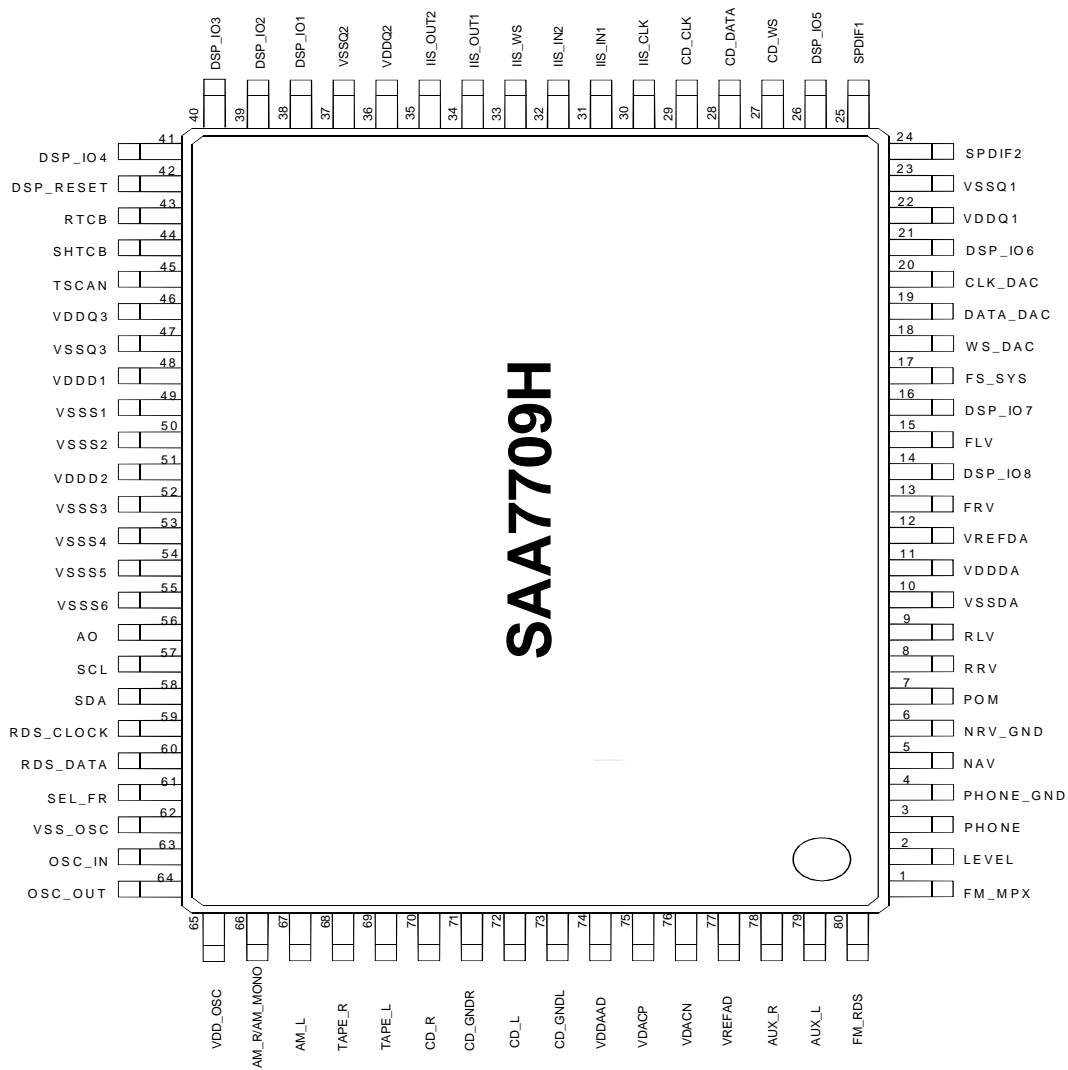

Fig 6.1 Pinning diagram

## 6.1 Pin description.

Table 1 Pin list SAA7709H

SYMBOL	PIN	DESCRIPTION
FM_MPX	1	Analogue input pin for FM-Multiplex signal
LEVEL	2	FM/AM-level input pin. Via this pin the level of the FM signal or level of the AM signal is fed to the CDSP. The level information is used in the DSP for signal correction
PHONE	3	Input of common mode phone signal
PHONE_GND	4	By I2C switchable common mode reference pin to enable an arbitrary high common mode analogue input for all 4 ADs.
NAV	5	Input of common mode navigation signal
NAV_GND	6	By I2C switchable common mode reference pin to enable an arbitrary high common mode analogue input for all 4 ADs.
POM	7	Power on Mute of the FSDAC. Timing is determined by an external capacitor and the internal current sources.
RRV	8	Rear Right audio voltage output of the FSDAC
RLV	9	Rear Left audio voltage output of the FSDAC
VSSDA	10	Ground supply analogue part of the FSDAC and SPDIF bitslicer
VDDDA	11	3V3 positive supply analogue part of the FSDAC and SPDIF bitslicer
VREFDA	12	Voltage reference of the analogue part of the FSDAC
FRV	13	Front Right audio voltage output of the FSDAC
DSP_IO8	14	Digital in/output 8 of the DSP-core (F7 of the status register)
FLV	15	Front Left audio voltage output of the FSDAC
DSP_IO7	16	Digital in/output 7 of the DSP-core (F6 of the status register)
FS_SYS	17	256- or N X FS clock output to be used together with an external DA converter
WS_DAC	18	Word Select signal to be used for an external DA converter
DATA_DAC	19	Data signal to be used for an external DA converter
CLK_DAC	20	Clock signal to be used for an external DA converter
DSP_IO6	21	Digital in/output 6 of the DSP-core (F5 of the status register)
VDDQ1	22	3V3 positive supply 1 peripheral cells only
VSSQ1	23	Ground supply 1 of peripheral cells only
SPDIF2	24	Analogue bitslicer input2 for SPDIF, can be selected i.s.o. SPDIF1 via I2C bit
SPDIF1	25	Analogue bitslicer input1 for SPDIF, can be selected i.s.o. SPDIF2 via I2C bit

DSP_IO5	26	Digital in/output 5 of the DSP-core (F4 of the status register)
CD_WS	27	I <sup>2</sup> S or LSB justified format Word select input from a digital audio source
CD_DATA	28	I <sup>2</sup> S or LSB justified format Left-Right Data input from a digital audio source
CD_CL	29	I <sup>2</sup> S Clock or LSB justified format input from a digital audio source
IIS_CLK	30	Clock output for external I <sup>2</sup> S receiver. For example headphone/ subwoofer
IIS_IN1	31	Data 1 input for external I <sup>2</sup> S transmitter, e.g. audio co-processor
IIS_IN2	32	Data 2 input for external I <sup>2</sup> S transmitter, e.g. audio co-processor
IIS_WS	33	Word select output for external I <sup>2</sup> S receiver. For example headphone/ subwoofer
IIS_OUT1	34	Data1 in/output for external I <sup>2</sup> S receiver. For example headphone/ subwoofer
IIS_OUT2	35	Data2 in/output for external I <sup>2</sup> S receiver. For example headphone/ subwoofer
VDDQ2	36	3.3 V positive supply 2 peripheral cells only
VSSQ2	37	Ground supply 2 of peripheral cells only
DSP_IO1	38	Digital in/output 1 of the DSP-core (F0 of the status register). Input level must always be defined externally in the application
DSP_IO2	39	Digital in/output 2 of the DSP-core (F1 of the status register). Input level must always be defined externally in the application
DSP_IO3	40	Digital in/output 3 of the DSP-core (F2 of the status register)
DSP_IO4	41	Digital in/output 4 of the DSP-core (F3 of the status register)
DSP_RESET	42	Reset of the DSP core (active low)
RTCB	43	Asynchronous Reset Test Control Block active low, may not be connected in the application
SHTCB	44	Shift Clock Test Control Block, may not be connected in the application
TSCAN	45	Scan control active high, may not be connected in the application
VDDQ3	46	3V3 positive supply 3 peripheral cells only
VSSQ3	47	Ground supply 3 peripheral cells only
VDDD1	48	3V3 positive supply 1 core and internal supply IO ring
VSSS1	49	Ground supply 1 of 3.3 volt core only
VSSS2	50	Ground supply 2 of 3.3 volt core only
VDDD2	51	3V3 positive supply 2 core only
VSSS3	52	Ground supply 3 of core, internal ground supply ring and substrate
VSSS4	53	Ground supply 4 of core, internal ground supply ring and substrate
VSSS5	54	Ground supply 5 of core only



VSSS6	55	Ground supply 6 of core only
A0	56	Slave sub-address I <sup>2</sup> C selection / Serial data input test control block
SCL	57	Serial clock input I <sup>2</sup> C bus. Must always be defined by application.
SDA	58	Serial data input / output I <sup>2</sup> C bus
RDS_CLOCK	59	Radio Data System bit clock output / RDS external clock input
RDS_DATA	60	Radio Data System data output
SEL_FR	61	AD input selection switch to enable high ohmic FM_MPX input at fast tuner search on FM_RDS input. Must always be defined by application.
VSS_OSC	62	Ground supply crystal oscillator circuit
OSC_IN	63	Crystal oscillator input: crystal oscillator sense for gain control or forced input in slave mode
OSC_OUT	64	Crystal oscillator output: Drive output to 11.2896 MHz crystal
VDD_OSC	65	3V positive supply crystal oscillator circuit
AM_R/AM_MONO	66	Analogue input pin for AM audio frequency Right Channel
AM_L	67	Analogue input pin for AM audio frequency Left Channel or AM mono
TAPE_R	68	Input of the analogue TAPE Right signal
TAPE_L	69	Input of the analogue TAPE Left signal
CD_R	70	Input of the analogue CD Right signal
CD_GNDR	71	By I2C switchable common mode reference pin to enable high common mode analogue input for the CD_R input or a high common mode analogue input for all 2 ADs for right channel processing
CD_L	72	Input of the analogue CD Left signal
CD_GNDL	73	By I2C switchable common mode reference pin to enable high common mode analogue input for the CD_L input or a high common mode analogue input for all 2 ADs for left channel processing
VDDAAD	74	Positive supply analogue AD1..4 and Level AD.
VDACP	75	Positive reference voltage ADC1..4 and Level AD
VDACN	76	Ground supply analogue AD1..4 and Level AD.
VREFAD	77	Common mode reference voltage AD1..4 and Level AD
AUX_R	78	Input of the analogue Auxiliary Right signal
AUX_L	79	Input of the analogue Auxiliary Left signal
FM_RDS	80	Analogue input pin for FM RDS signal

## 7 Functional description of the CDSP modes and functions.

### Introduction.

The CDSP block diagram is depicted in figure 5.1. For a thorough description of the CDSP block diagram see the data sheet of the SAA7709H. In this chapter a general overview is given of all modes and functions.

The CDSP can be set in several operation modes. Each mode executes functions which are required for that particular mode, furthermore the CDSP can process two independent sources simultaneously (dual media modes), note that NOT all combinations are possible, for example AM-mode and FM-mode, two digital input modes are only possible when the the (external) digital sources are synchronous and locked to each other.

The selection of a particular mode is software controlled (via the I2C bus) and described in chapter 9. The required inputs for each mode can be selected by the analogue or digital source selectors which are software controlled (via the I2C bus). The source selection is also described in chapter 9.

### 7.1 Audio processing

All basic audio processing in the CDSP chip is performed by the integrated digital signal processor (DSP).

The signal flow is more or less fixed and the functions are controlled by sending coefficient values to the appropriate places in the DSP processor coefficient memory via the I<sup>2</sup>C bus.

The functions of the Audio processing block are always executed independent of the mode. The Audio processing block consists of two parts, the audio processing functions for the primary channel and the audio processing functions for the secondary channel.

The following functions have been implemented:

#### - Volume control

The volume control function determines the output voltage of the CDSP. The volume control is split into a gain and a attenuation section which acts equal for both channels. The volume control contains also a prescaling which ensures that for the various input signals the same sound pressure level (for a fixed volume setting) can be obtained at the output of the CDSP. The primary- and secondary channel have independent volume control.

#### - Balance

The balance function controls the attenuation of either the left or the right channel while the other channel is kept constant. Separate balance functions are available in the primary- and secondary channel.

#### - Fader

This function is **only** implemented for the primary channel  
The fader function controls the attenuation of either the front or rear channels while the other channels are kept constant. The fader is controlled via the I2C bus.

#### - Soft audio mute

The soft audio mute function enables the user to generate a gradual mute or de-mute function without

undesired clicks. The Soft Audio Mute is implemented as a linear ramp. There is one SAM function for the primary channel and the subwoofer output, the secondary channel has a separate SAM function.

### **- Parametric Equaliser**

2 sections of 2x5 bands each are available, they can be used in the primary and/or the secondary channel in the main audio program.

## **7.2 FM mode**

This is the mode for FM reception and runs in the DSP. The selected input is FM-MPX or FM-RDS

The program in the FM mode offers the following functions:

### **Enhanced FM dynamic signal processing**

The FM dynamic signal processing adapts the FM audio characteristics depending on the quality of the received station. As criterion to judge this quality the following parameters are used:

- the level signal as a measure for the fieldstrength
- the multipath detector output as a measure for the multipath distortion
- the noise above 60 kHz of the MPX signal as a measure for the adjacent channel interference

From the audio characteristics the output level (softmute), the stereo image (sliding stereo to mono) and the audio frequency response (high cut control) are adapted. The following functions are implemented:

- Softmute as a function of level and noise:
  - fast attack and recovery at level dips with a low repetition rate
  - fast attack with slow recovery at dips with a high repetition rate or with a long duration
  - fast attack and recovery at adjacent channel breakthrough
- Stereo control (sliding stereo) as a function of level, noise and multipath:
  - fast attack and recovery at level dips, noise or multipath bursts with a low repetition rate
  - fast attack with slow recovery at events with a high repetition rate or with a long duration
- Audio frequency response control as a function of level, noise and multipath:
  - fast attack and recovery at level dips, noise or multipath bursts with a low repetition rate
  - fast attack with slow recovery at events with a high repetition rate or with a long duration.

### **Adjustment of channel separation**

The purpose of this function is to compensate for the non flat frequency response around 38 kHz of the FM tuner which causes extra cross-talk.

### **FM De-emphasis filter and 19 kHz MPX filter**

The purpose of the de-emphasis filter is to compensate the pre-emphasized FM signal with a filter with a time constant of 50  $\mu$ s or 75  $\mu$ s. The notch filter at 19 kHz is used to protect tweeters in high power applications from overload by the stereo pilot.

### **FM audio filter**

The purpose of the FM audio filter is to set the audio bandwidth in FM mode independent from the

other modes.

### **Stereo detection**

The purpose of the stereo detector is to indicate the presence of a pilot tone and that the stereo decoder is in lock.

### **Noise filter**

The noise level is detected in a band from 60 kHz till 120 kHz with an envelope detector (see data sheet). The noise level is used as adjacent channel information for the controller and for the FM dynamic signal processing.

### **RDS updates**

This function offers the following features:

- Pause detection  
The purpose of the pause detection is to search for a pause in the FM signal.  
A pause is detected when the FM signal is below a pre-defined level for a certain amount of time.  
The output of the pause detector is the DSP\_IO4 pin (pin 41). "High" indicates pause.
- Mute  
The purpose of the mute is to mute the FM signal that goes to the audio processing block.  
This mute is activated by the external control pin DSP\_IO1 (pin 38). "Low" is mute.
- Hold function  
The purpose of the hold function is to prevent that the information retrieved during an RDS update can disturb the filters in the FM signal processing block. The hold function is activated by the external control pin DSP\_IO1 (pin 38). "Low" is hold.
- Freeze function  
The purpose of the freeze function is to freeze the level, noise and multipath values measured during an RDS update and to read them out after the update. The freeze function is activated by the external control pin DSP\_IO2 (pin 39). "Low" is freeze.

### **Interference absorption circuit (IAC)**

The Interference Absorption Circuit (IAC) detects and suppresses ignition interference. The characteristics of the IAC can be adapted to the properties of different FM tuners by means of the predefined coefficients in the IAC control register. The values can be changed via the I<sup>2</sup>C bus. On power on the nominal setting for a good performing IAC is selected (all IAC control bits are set to their default value, according the I<sup>2</sup>C hardware register definition).

### **7.3 AM-mono mode**

This is the mode for mono MW, LW or SW reception, the selected input is AM\_R.  
The program in the AM-mono mode runs in the DSP and offers the following functions:

#### **AM dynamic signal processing**

The AM dynamic signal processing adapts the AM audio characteristics depending on the quality of the received station. As criterium to judge this quality the level signal as a measure for the fieldstrength is used.

From the audio characteristics the output level (softmute) and the audio frequency response (high cut control) are adapted. The following functions are implemented:

- Soft mute as a function of level
- Audio frequency response control as a function of level

#### **6th order Low-pass filter**

The purpose of the low-pass filter is to suppress interference whistles from adjacent channels and noise.

#### **AM IAC**

The AM IAC (interference absorption circuitry) detects and eliminates audible clicks caused by impulsive interference, such as caused by engine ignition or fan, on AM reception.  
The characteristics of the AM IAC can be adapted to the properties of different AM tuners by means of coefficients in the YRAM of the DSP

#### **AM Quality detection**

The AM Quality feature detects interfering signals caused by adjacent- and co-channel interference. This feature is available only during search mode of the AM-tuner. The audio output is muted during search mode.

### **7.4 General purpose tone generator**

The tone generator generates a sinewave signals on the Left- and Right audio channel and can be selected as main audio source. The tone generator can be used f.i. to test the speaker outputs in the car radio during production. The tone generator function is part of the audio program in the DSP and is therefor always available.

### **7.5 Tone sequencer**

The tone sequencer generates a wide range of bleeps and chime sounds with selectable frequency and wave form. These sounds can be used for audio feedback or for test purposes and can be added to the Primary and/or Secondary channel outputs.

The tone sequencer function is part of the audio program in the DSP and is therefor always available.

## 7.6 Noise generator

The noise generator produces white noise, the purpose of this function is automatic car acoustic measurements. The noise generator has an optional octave-band filter.

## 7.7 MSS function

The purpose of the Music Search (MSS) function is to search for the next pause on a cassette tape. The output of the MSS mode is the DSP\_IO5 pin (pin 26). This pin is "High" when the level of the input signals remain below a pre-defined level for a certain amount of time.

## 7.8 Radio Data System (RDS) function

The selected input for this function is either FM-RDS or FM-MPX. This function offers the following features:

- Demodulation of the inaudible RDS information, which is transmitted by FM broadcasting and is sent it to a suitable external decoder. Also a **internal RDS decoder is available** to decode the demodulated RDS information. RDS information is then available via I2C communication.
- two tuners concept. There are two different input pins from which the RDS information can be retrieved. The demodulated RDS information is available by each bit or buffered by 16 bits.

## 7.9 Second processor extension function

This function offers the possibility of the addition of a second DSP which offers special, more sophisticated features such as acoustic and room effects.

## 8 Hardware application of the CDSP

### General

In this chapter the external components are discussed, sometimes in combination with the on chip input/output circuits.

How to select specific inputs and operating modes is described in chapter 9 of this manual.

The external components are depicted in the CDSP application diagram which can be found in appendix 1. It must be stressed here that this application diagram is an example, **not** the ultimate application diagram.

There is also an application diagram of the application board (not in the usermanual) and that contains much more components in order to optimise the EMC.

### 8.1 Audio processing in DSP

In this chapter the following hardware functions will be covered

- Analogue outputs (D/A convertors)
- Voltage and current reference sources
- Power on/off mute
- DSP reset

#### 8.1.1 Analogue outputs (pin 8, 9, 13 and 15)

There are 4 analogue outputs namely those which make the outputs of the 4 bitstream DACs (Front Left/Right and Rear Left/Right). The D/A convertors contain an internal filter so no external filter is required. The basic block diagram of one analogue output is depicted in figure 8.1.

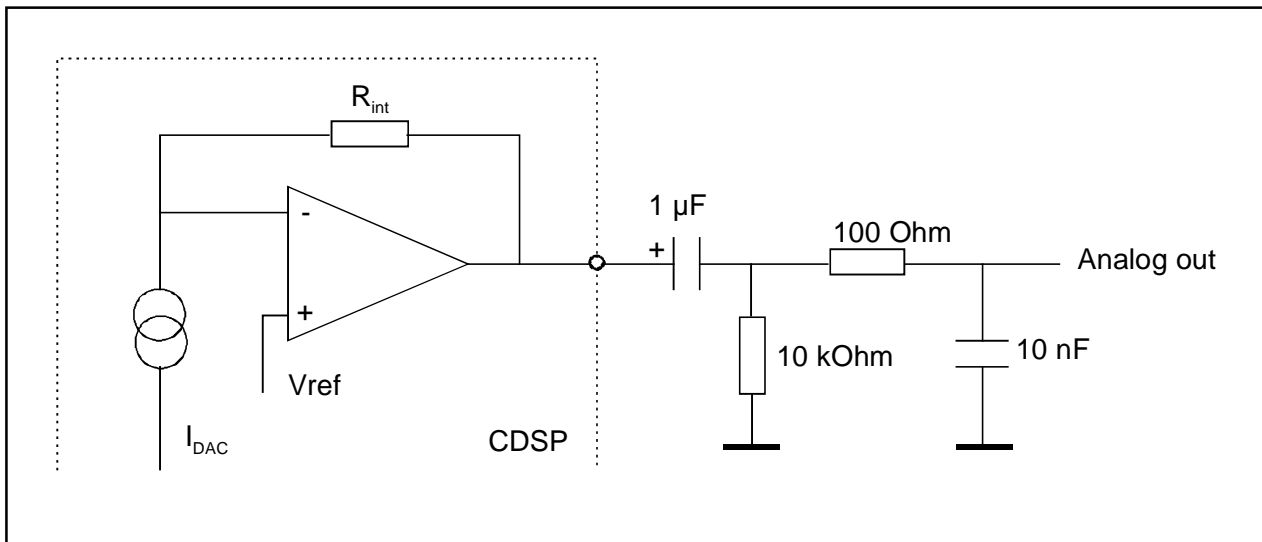

Fig. 8.1 Analogue output block diagram

An analogue output consists mainly of a current to voltage convertor.

A current to voltage convertor is constructed by using the internal CMOS op-amp and resistor as depicted in figure 8.1. The current from the Bistream DAC is converted into a voltage via Rint.

The full scale output voltage of the DAC is 1 Vrms. The DAC outputs require a AC load that may not drop under the 2 kΩ. In the application 10 kΩ resistors are used (R26, R28, R30 and R32).

The DC output voltage is the same as VREFDA (typ. 1.65V). This DC is removed by the electrolytic capacitors C34, C36, C38 and C40. The cut-off frequency (and phase non-linearity) of these high pass filters depends on the DAC load resistance and/or input impedance of the equipment behind the CDSP.

The extra 1st order RC filter is to suppress radiation from the analogue output to the outside world ( $f_c = 160 \text{ kHz}$ ) (R27, R29, R31, R33, C35, C37, C39, C41). The cut-off frequency is not critical (component tolerance of 20% is tolerable). These filters may be omitted if considered not necessary.

### 8.1.2. Internal reference voltage sources VREFDA (pin 12) and VREFAD (pin 77)

The block diagram of the reference voltage sources VREFDA and VREFAD is depicted in figure 8.2.

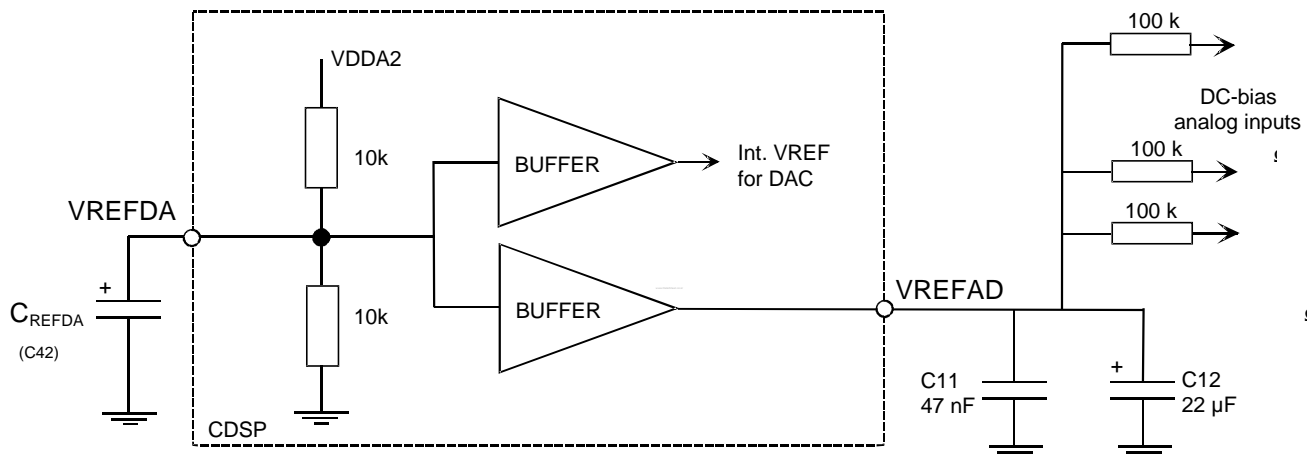

**Fig. 8.2** Internal reference voltage sources block diagram

The supply voltage VDDA2 is divided by two internal 10 kΩ resistors and buffered. The output of the first buffer is called the internal Vref and is used as the reference voltage for the D/A converters.

The output of the second buffer is connected to pin VREFAD (pin 77) and is internally used as the 1.65 V reference voltage of the switch capacitor D/A converters (and buffers) of the level A/D convertor, ADC1/2 and ADC3/4.

As filtering for the internal reference voltages a capacitor is added at the VREFDA pin.

In the CDSP application we use:

$$f \geq 1 \text{ kHz (Vripple}=100 \text{ mV), ripple rejection (PSRR)= typ. 60 dB, CREFDA}=22 \text{ } \mu\text{F (C42).$$

The VREFAD voltage is also used as a DC-bias for the analogue AM, Tape and CD inputs via 82 kΩ / 100 kΩ resistors. Due to the low output impedance of the buffer, the crosstalk between the analogue inputs is  $\leq -74 \text{ dB}$  at DC, the external 22 μF elco (C12) is added to further improve the crosstalk rejection to  $\leq -80 \text{ dB}$  at 1 kHz. The 47 nF capacitor (C11) is added to remove high frequency noise on the midref voltage for the A/D converters.



### 8.1.2.3 Ref. voltages for the AD convertors VDACP (pin 75) and VDACN (pin 76)

The block diagram of the reference voltages for the AD convertors is depicted in figure 8.3.

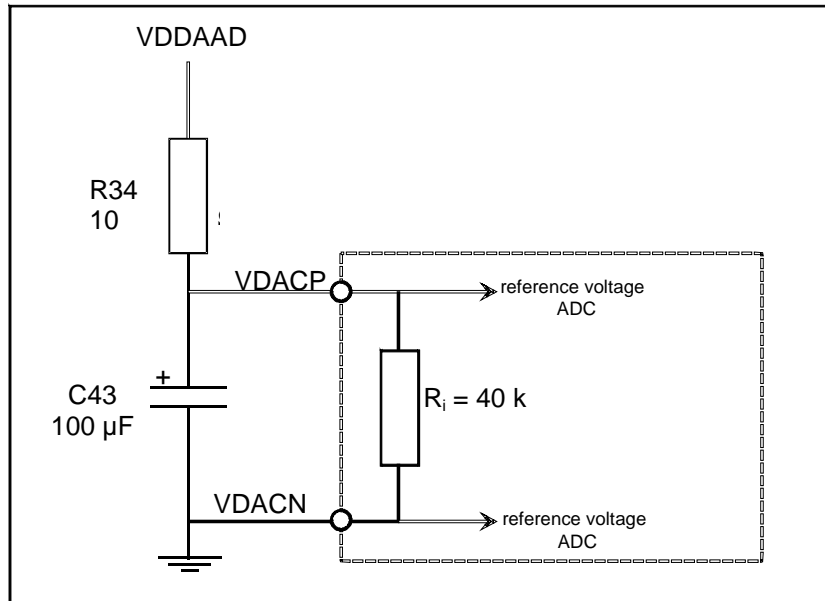

**Fig. 8.3** Block diagram reference voltages AD convertors.

The voltages at the pins VDACP and VDACN1 are the reference voltages for the AD convertors, for good performing AD's it is important that these reference voltages are clean.

The external 10 Ω resistor (R34) and 100 μF elco (C43) filter the analogue supply voltage VDDAAD and are added to improve the power supply rejection ratio (PSRR).

In the CDSP application we use:

$f \geq 1$  kHz (V<sub>ripple</sub>=100 mV), ripple rejection (PSRR)= typ. 39 dB, C<sub>REFDA</sub>=100μF (C43).

### 8.1.3 Power on/off mute

The block diagram of the power on mute (POM) circuit is depicted in figure 8.4.

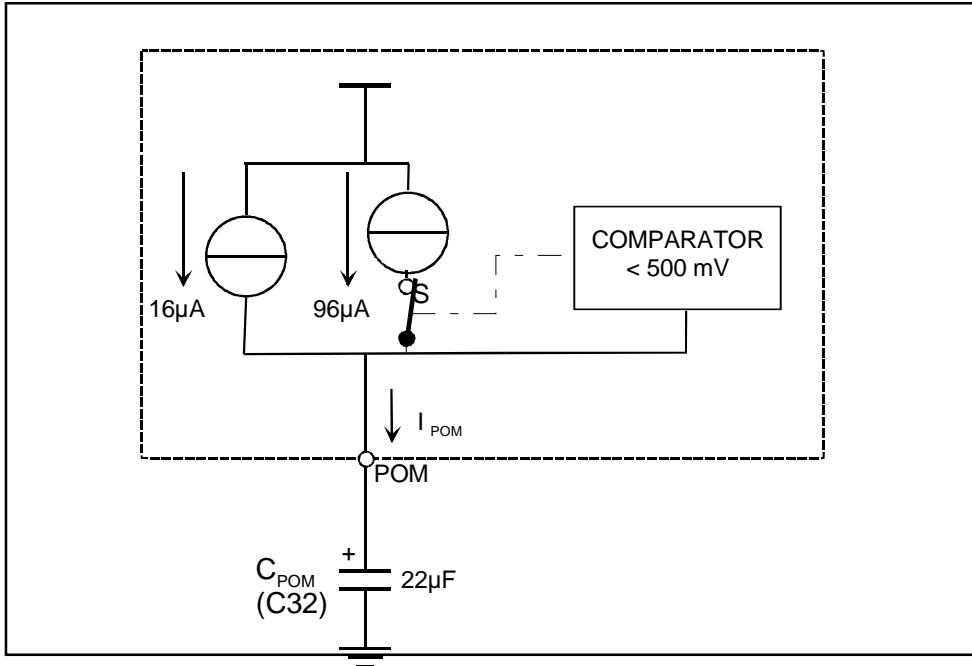

Fig. 8.4 Power on mute block diagram

#### Power on Mute (pin 7)

To avoid any uncontrolled noise at the audio outputs after power-on/off of the IC, the internal reference current source of the D/A converter is controlled. The capacitor on the POM pin (C32) determines the switch-on timing of this current. See figure 8.5

At power-on the the switch **S** is closed and the current out of the POM pin ( $I_{POM}$ ) is  $16 \mu A$ , the capacitor  $C_{pom}$  gets charged by  $I_{POM}$  and the voltage at the POM pin ( $V_{POM}$ ) increases linearly until  $V_{POM} = 0.5 V$ , at this point the comparator is triggered and switch **S** is opened. As a result  $I_{POM}$  becomes  $112 \mu A$  and  $V_{POM}$  increases fast until it reaches  $V_{DDA}$ .

As a result of this POM control the  $V_{out-AC}$  at the DAC outputs (in dB) increases almost dB linear from  $-100 \text{ dBFS}$  till  $0 \text{ dBFS}$ .

At time= $t_{pom}$  the DAC output  $V_{out-AC} = -25 \text{ dBFS}$ , before this output voltage is reached the chip must be resetted. After the reset the chip comes automatically in the idle mode via the DSP program (see also chapter 9). This DSP program sets the outputs of the digital upsampling filters to digital silence and therefore the AC output current of the DAC's to  $0 \mu A$  (see also in the next chapter).

The time  $t_{pom}$  as function of  $C_{pom}$  is :  $t_{pom} = 0.03125 * C_{pom}$  ( $C_{pom}$  in  $\mu F$ )

The time  $t_s$  during which the output voltage further increases from  $-25 \text{ dBFS}$  to  $0 \text{ dBFS}$  is :

$$t_s = 0.8 * t_{pom}$$

In the CDSP application we use:  
 $T_{pom} = 690 \text{ msec } (\pm 20\%)$   
 $C_{pom} = 22 \mu F \text{ (C32)}$

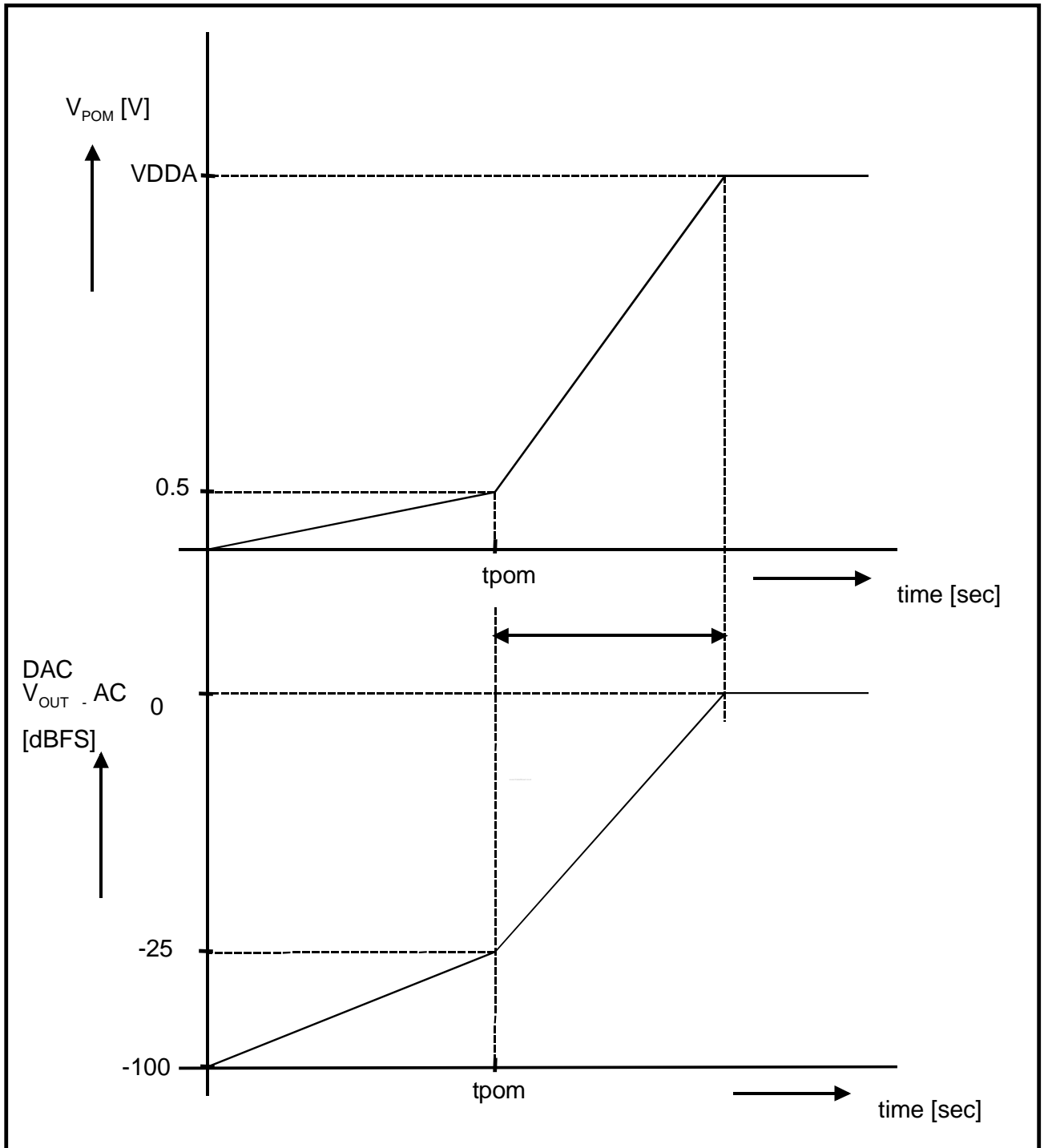

**Fig. 8.5** Switch-on timing DAC

## Power off plop suppression

To avoid plops in a power amplifier, the supply voltage of the analogue part of the D/A converter and the op-amps are fed by an external voltage regulation circuit (R9, R10 and TR2) and an extra capacitor (C31) as indicated in the application diagram. During power-off the output voltage will decrease gradually, allowing the power amplifier some extra time to switch off without audible plops.

In addition the POM should be pulled to zero by the  $\mu$ Processor before the power supply of the digital circuitry (VDDDD1, VDDDD2) is below 2.2V. Below this value the digital circuitry is undefined and can therefore cause extra undesirable clicks during power-off.

### 8.1.4 DSP Reset (pin 42)

The reset pin is active low and requires an external pull-up resistor of 47 k $\Omega$ . Between the reset pin and the ground a capacitor should be connected to allow a proper switch-on of the supply voltage. The capacitor value is such that the chip is in reset as long as the power supply is not stabilised. A more or less fixed relationship between the DSP reset (pin 42) time constant and the POM (pin 7) time is obligatory. The voltage on the POM pin determines the current flowing in the DACs. At 0 V at the POM pin the DAC currents are zero and so are the DAC output voltages. At 3.3 V the DAC currents are at their nominal value. Long before the DAC outputs get to their nominal output voltages, the DSP must be in working mode to reset the output register of the digital filter, therefore the DSP reset time constant must be shorter than the POM time ( $t_{pom}$ ).

The dsp reset input is a digital input (with hysteresis) and that means that the dsp reset circuit is enabled when  $V_{cdspres}=80\%V_{dd}$ .

In the CDSP application we use:

$$\begin{aligned} T_{dspres} &= 68 - 92 \text{ msec (tolerance is due to tolerance of the external pull-up resistor} \\ &\quad \text{and the capacitor tolerance (10\%)} \\ C_{dspres} &= 1 \text{ }\mu\text{F} \end{aligned}$$

In calculating  $T_{dspres}$  it is assumed that  $V_{cdspres}=80\%V_{ddd}$  and the formula to calculate  $T_{dspres}$  is:

$$V_{cdspres} = V_{ddd} * (1 - e^{-T_{dspres}/RC})$$

The reset has the following functions:

- the bits of the I2C hardware register are set to their preset values
- the program counter is set to address \$0000
- DSP\_IO1 .. DSP\_IO7

When the level on the reset pin is at logical high ( $V_{cdspres}=80\%V_{ddd}$ ), the DSP program in the DSP starts to run from the idle mode, resets the output registers of the digital filters and the  $\mu$ Processor can start sending commands.

General timing requirements are:

$T_{dspres}$	>	$T_{power}$
$T_{pom}$	>	$T_{dspres}$
$T_{\mu Pcomm}$	>	$T_{dspres}$

Figure 8.6 gives an overview of the several time constants.

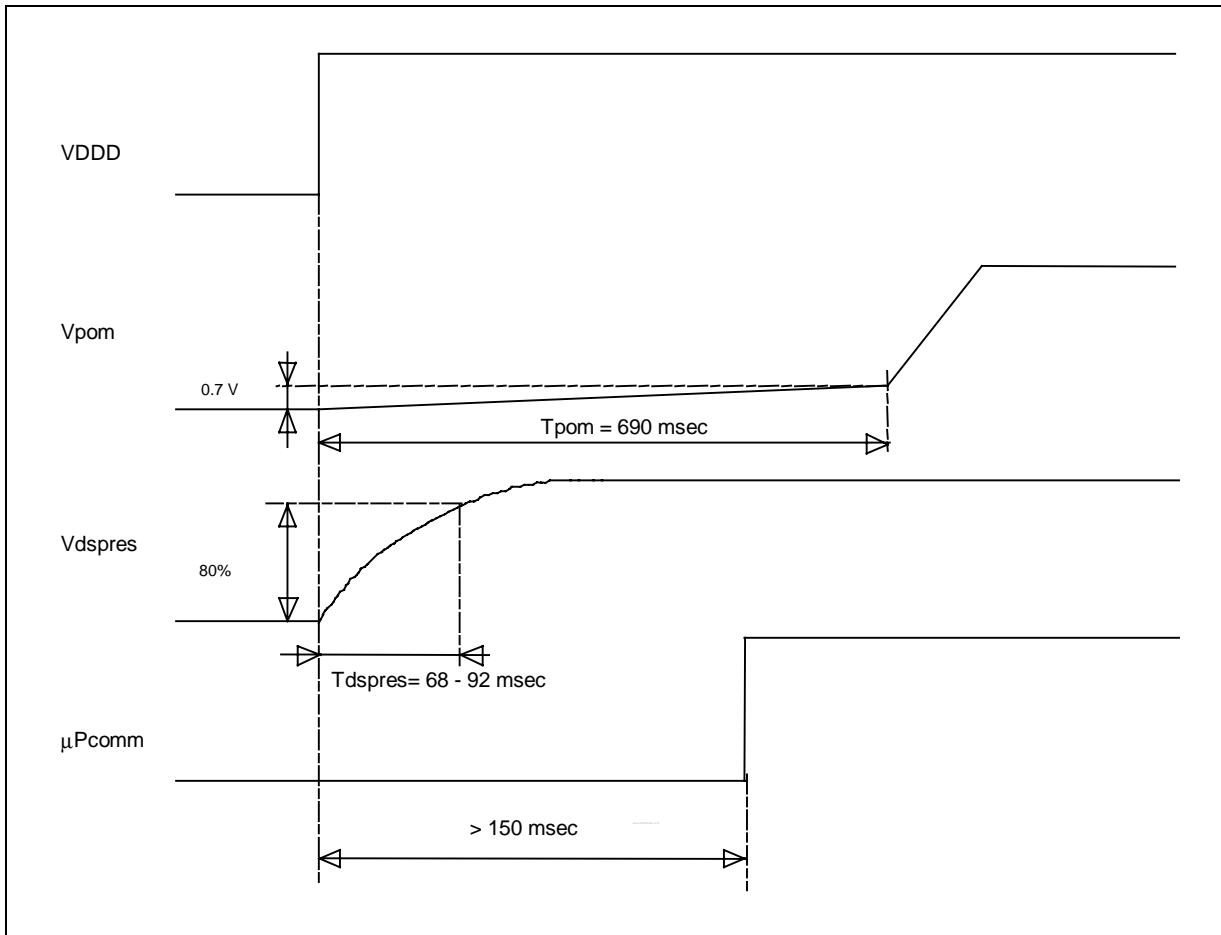
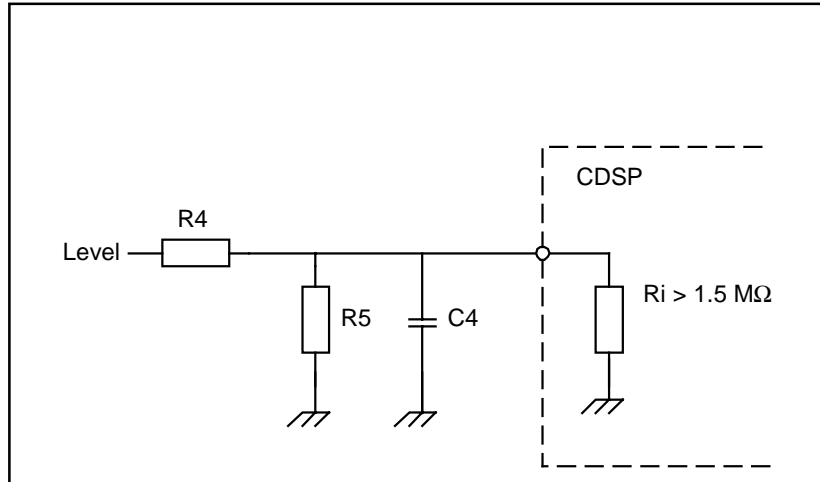

**Fig. 8.6** Power-up timing diagram to avoid clicks

## 8.2 AM / FM signal quality processing

### Level (pin 2)

The basic circuit diagram of the level input is depicted in figure 8.7.



**Fig. 8.7** Level input

The level signal from the tuner is divided with resistors R4 and R5 in order to match the conversion range of the Level A/D convertor to the tuner properties.

With R4, R5 and C4 a first order low pass filter is realised at the level input.

The cut-off frequency of this filter is :

$$f_c = \frac{1}{2 \cdot \pi \cdot \frac{R4 \cdot R5}{R4 + R5} \cdot C4}$$

The low pass filter at the input of the FM level pin has two functions:

- to avoid aliasing in the level A/D convertor, that means that frequency components of  $f > 1/2 f_{s_{A/D}} < 54$  dB below the maximum input of the level A/D convertor (figure for S/N for level A/D convertor, mentioned in data sheet)
- to create a filter for the multipath detector with a cut-off frequency of 34 kHz ( $\pm 20\%$ )

These functions are realised with R4=27 k $\Omega$  ( $\pm 10\%$ ), R3=100 k $\Omega$  ( $\pm 10\%$ ) and C1= 220 pF ( $\pm 10\%$ ). The capacitor is connected to the ground plane.

#### Remarks:

- a) The source resistance is not taken into account because this  $R_{source} \ll (127 \text{ k}\Omega)$  otherwise the cut-off frequency is affected.
- b) The input resistance of the CDSP is not taken into account because this  $R_{in}$  is big (1.5 M $\Omega$  min.).

The conversion range of the A/D convertor is from 0 V to VDDA1 (see spec in the data sheet). The voltage range of the FM level information has to be within this range. The total voltage range of the level information has to be  $\geq 1/2 VDDA1$  to meet the minimum resolution.

## 8.3 FM mode

### 8.3.1 FM input pins

#### SEL\_FR (pin 61)

The function of the SEL\_FR pin is to select in FM mode between the FM-MPX and FM-RDS input. This pin has a Schmitt trigger input and needs no external components because the applied signal is static (0V or 3.3V). Note that this pin is not used in the application diagram (appendix 1) and therefore connected to ground.

#### FM-MPX (pin 1) and FM-RDS (pin 80)

The basic circuit diagram of the FM-MPX and FM-RDS inputs is depicted in figure 8.8.

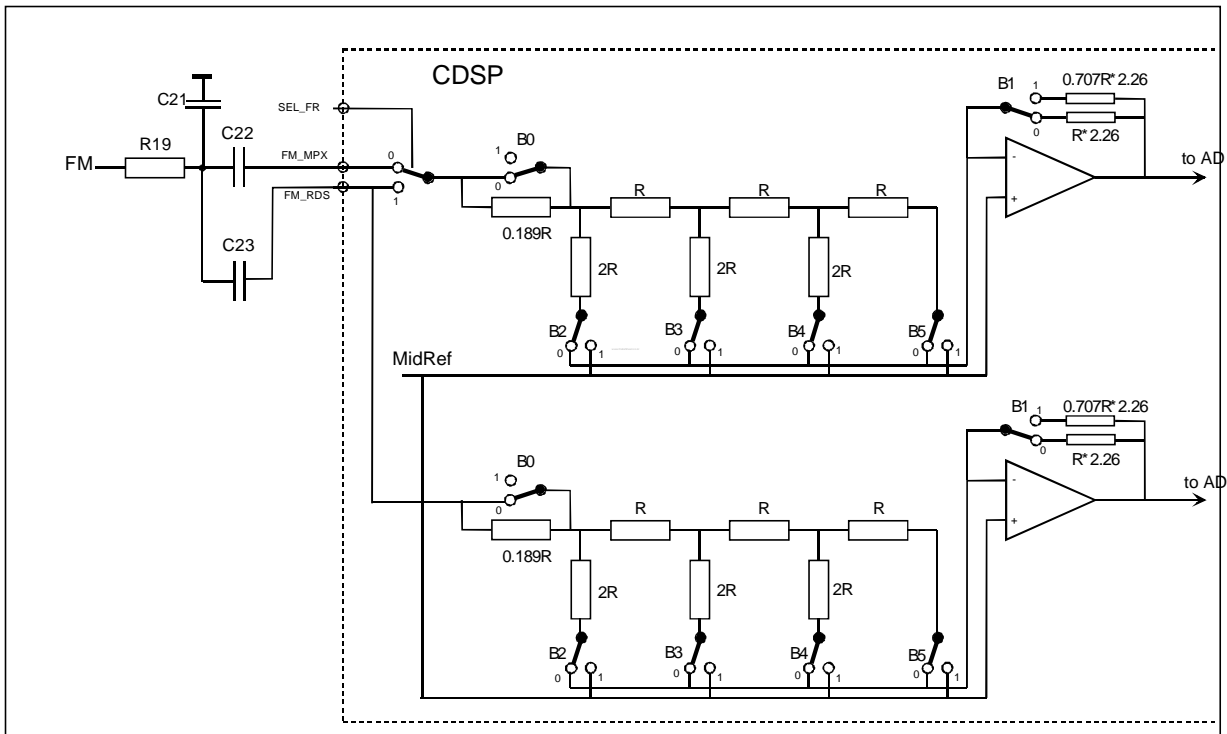

Fig. 8.8 FM-MPX and FM-RDS input

The 1st order RC filter (R19 and C21) at the input of the FM-MPX pin has two functions:

- to avoid aliasing in the A/D convertor, that means that frequency components of  $f > 1/2 f_{sA/D} < 83 \text{ dB}$  below the maximum input of the A/D convertor (figure for S/N for ADC1 and ADC2 convertors, mentioned in data sheet)
- to create a filter for the FM-MPX input with a cut-off frequency  $> 250 \text{ kHz}$

This filter is realised with  $R19=1.8 \text{ k}\Omega (\pm 10\%)$  and  $C21=270 \text{ pF} (\pm 10\%)$ , in combination with the FM\_MPX input resistance of  $> 48 \text{ k}\Omega$  this results in a cut-off frequency of  $340 \text{ kHz} (\pm 20\%)$ .

#### Remarks:

- a) The source resistance is not taken into account because this  $R_{\text{source}} \ll 27\text{K}$  otherwise the cut-off frequency is affected.
- b) The input resistance of the CDSP ( $> 48 \text{ k}\Omega$ ) is taken into account for the cut-off frequency.
- c) Concerning C22 and C23, X7R SMD capacitors are **not** allowed because they show some voltage dependency which causes extra distortion, therefore NP0 SMD capacitors are recommended.

The capacitor C22 is applied to block any DC content of the incoming signal. The capacitor C22 forms with the Rin of the CDSP a high pass filter which must fulfil the following requirements:

- maximum leakage current  $< 0.5 \mu\text{A}$ , otherwise the specified dynamic range of the A/D convertor is limited by an offset voltage ( $I_{\text{leak}} * R_{\text{in,max}}=V_{\text{offset}}$ );  $0.5 \mu\text{A} * 60\text{K} = 30 \text{ mV}$  offset (in case of  $200 \text{ mV}$  input sensitivity), compared to  $1.229 \text{ V}_{\text{rms}}$  input voltage this results in a loss of dynamic range of  $0.2 \text{ dB}$ .
- the cut-off frequency  $\leq 5 \text{ Hz}$ , a higher  $f_c$  limits the maximum channel separation of FM due to phase shift at  $19 \text{ kHz}$ . In the CDSP application we use  $C22 = 1 \mu\text{F}$  (MKT).
- during a RDS update the switch is pointed to the FM\_RDS pin. For a fast update it is necessary to determine the value of C23 much smaller than C22. In the application we use  $C23 = 330 \text{ pF}$  (MKT).

### 8.3.2 FM input sensitivity selection

The FM input sensitivity is designed for tuner front ends which deliver an output voltage in the range of  $60 \text{ mV}$  to  $237 \text{ mV}$  ( $a_f = 1 \text{ kHz}$ ,  $22.5 \text{ kHz}$  deviation). The input sensitivity can be changed in steps of  $1.5 \text{ dB}$  by means of the 6 *volfm* bits (bits 7 ..12 of register  $\$0FF8$ ).

The maximum gain of the FM-MPX and FM-RDS input circuit is  $2.26$  ( $7.08 \text{ dB}$ ), the switches in fig. 8.8 are drawn in the  $7.08 \text{ dB}$  gain position. In this gain position the input sensitivity is  $60 \text{ mV}$  at  $22.5 \text{ kHz}$ , the full scale input level in this case is  $340 \text{ mV}$  ( $0 \text{ dBFS}$  at the input of DSP1) corresponding with a deviation of  $138 \text{ kHz}$ .

The input impedance of the FM-MPX and FM-RDS input circuits depends on the setting of bit **B0**; in case  $B0 = 0$  the input impedance is 'R' in case  $B0 = 1$  the input impedance =  $1.189 R$ . The value of the internal resistor  $R = 50\text{k}\Omega$  typical.



The input sensitivity as function of the setting of the volfm bits is given in table 8.1.

The input sensitivity of the FM-RDS input can be set independent from the FM-MPX input with the 6 *volrds* bits (bits 1 ..6 of register \$0FF8), table 8.1 also applies for the FM-RDS input.

The gain settings -6.4 dB ... -15.4 dB are not applicable for the MPX inputs because signal levels in the OpAmp input stage in front of the AD would exceed the rail to rail levels far before the 0 dBFS input level is reached at the DSP1 input.

TUNER OUTPUT VOLTAGE (mV) at $\Delta f = 22.5$ kHz	Gain (dB)	volfm I2C bits (11:6)	0 dBFS input level (mV) of FM-MPX and/or FM-RDS via stereo decoder to DSP1	Typical Input impedance [Ohms]
60	+7.1	\$00	340	50 k
71	+5.6	\$01	404	60 k
85	+4.1	\$02	480	50 k
100	+2.6	\$03	571	60 k
120	+1.1	\$04	678	50 k
142	-0.4	\$05	806	60 k
170	-1.9	\$06	961	50 k
<b>200</b> (default position)	<b>-3.4</b>	<b>\$07</b>	<b>1135</b>	60 k
237	-4.9	\$0C	1350	50 k
n.a.	-6.4	\$0D		60 k
n.a.	-7.9	\$0E		50 k
n.a.	-9.4	\$0F		60 k
n.a.	-10.9	\$1C		50 k
n.a.	-12.4	\$1D		60 k
n.a.	-13.9	\$1E		50 k
n.a.	-15.4	\$1F		60 k
n.a.	MUTE	\$3F		60 k

**Table 8.1** FM input sensitivity and impedance

### 8.3.3 FM IAC

The Interference Absorption Circuit (IAC) detects and eliminates audible clicks caused by impulsive interference on FM reception. The block diagram of the IAC is depicted in figure 8.9.

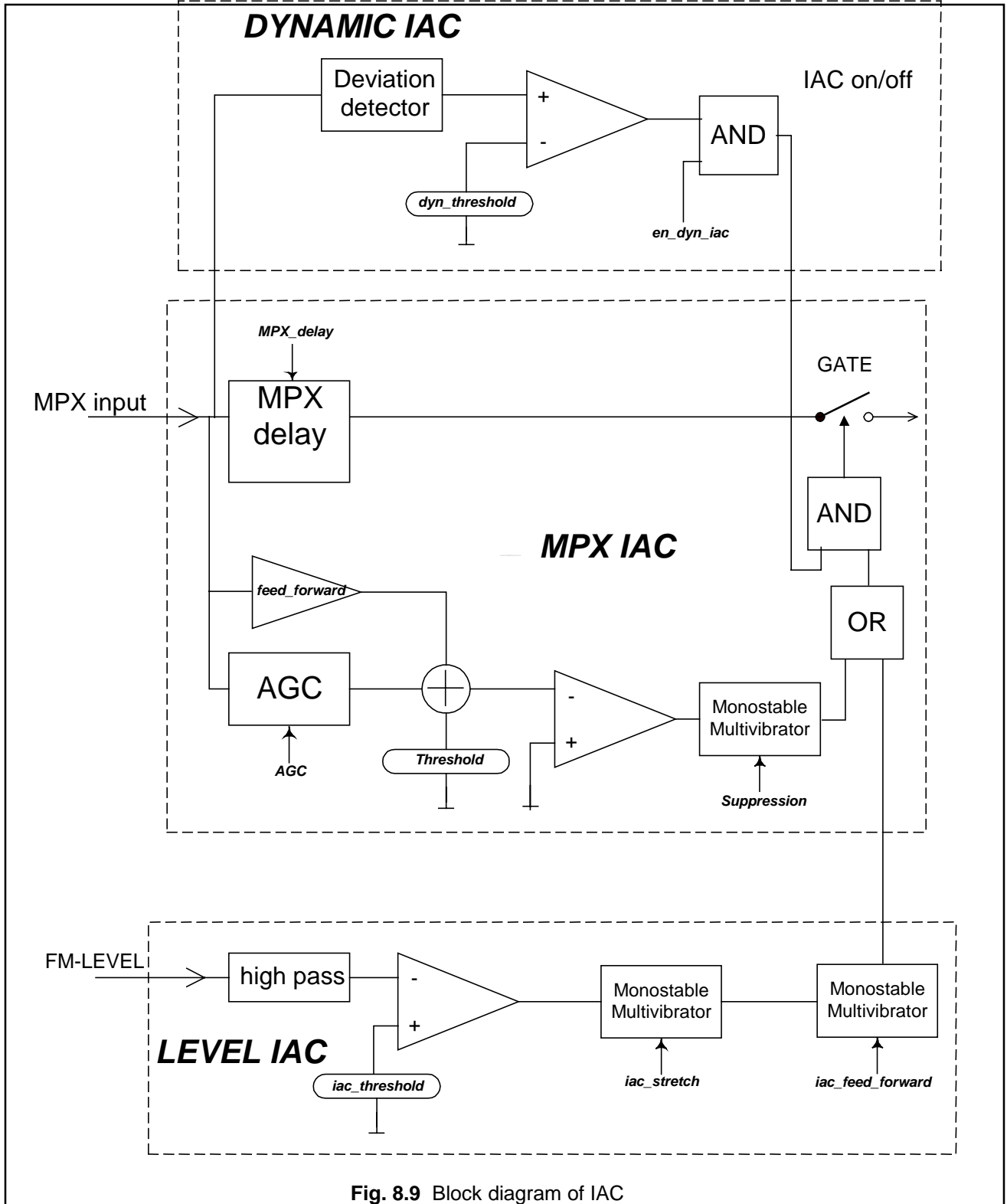

Fig. 8.9 Block diagram of IAC

The IAC consists of three circuits :

- MPX IAC
- Level IAC
- Dynamic IAC

The input signal of the MPX-IAC circuit is the MPX signal derived from the decimated output signal of the A/D convertor. The MPX signal is fed to a delay circuit followed a gate switch. This gate is activated by the interference detector which consists of a feed forward path, an AGC circuit, a comparator and a monostable multivibrator. The interference detector analyses the high frequency content of the MPX signal and discriminates between interference pulses and other signals. The mute switch interrupts the normal signal flow, during mute switch activation the output is held at a constant level which is obtained from a LPF. The MPX-IAC circuit performs optimally in higher antenna voltage circumstances.

The input signal of the Level IAC circuit is the FM level signal. This detector is added to the IAC circuit in order to further optimise the IAC performance at lower antenna voltage circumstances. This detection circuit is complementary to the MPX-IAC detection circuit.

The third IAC function is the Dynamic IAC circuit. This function is intended to switch OFF the IAC completely at the moment that the MPX signal has a too high frequency deviation. In case the frontend tuner has narrow IF filters a too high frequency deviation will result in AM modulation that could be interpreted by the IAC circuitry as interference caused by the car's engine. By enabling the Dynamic IAC function this false triggering will be avoided. The characteristics of the IAC can be adapted to the properties of different FM tuners by means of the predefined coefficients in the hardware I2C registers **IAC settings**. The values can be changed via the I2C bus. On power on the nominal setting for a good performing IAC is selected (all IAC control bits set to there prefix value).

Note that the Level IAC and the Dynamic IAC functions are switched on after power on. There are in total 9 different coefficients which will be described in short.

#### **AGC** (bit 11 of IAC settings register)

In case the sensitivity and feed forward factor are out of range in a certain application, the set point of the AGC can be shifted.

#### **Threshold** (sensitivity offset) (bit 2,1,0 of IAC settings register)

Sets the threshold sensitivity of the comparator in the interference detector. It also influences the amount of unwanted triggering.

#### **feed\_forward** (bit 5,4,3 of IAC settings register)

Determines the reduction of the detector sensitivity. This mechanism prevents the detector from unwanted triggering at noise with modulation peaks.

#### **Suppression** (bit 8,7,6 of IAC settings register)

Sets the duration of the pulse suppression after the detector has stopped sending trigger pulses.

#### **MPX\_delay** (bit 10,9 of IAC settings register)

Sets the delay time (between 2 and 5 samples of  $F_s=304$  kHz) depending on the used front end of the car radio.

**lev\_iac\_threshold** (bit 16,15,14,13 of IAC settings register)

Sets the sensitivity of the comparator in the ignition interference pulse detector. It also influences the amount of unwanted triggering. With the value '0000' the Level IAC function is switched OFF.

**lev\_iac\_feed\_forward** (bit 18,17 of IAC settings register)

This parameter allows to adjust for delay differences in the signal paths from the FM antenna to the MPX mute, namely via the FM level ADC and Level IAC detection and via the FM demodulator and MPX conversion and filtering. These differences depend on the used frontend tuner in the car radio.

**lev\_iac\_stretch** (bit 20,19 of IAC settings register)

Sets the duration of the pulse suppression after the FM level input has stopped exceeding the threshold level.

**lev\_dyn\_threshold** (bit 22,21 of IAC settings register)

If enabled by the **en\_dyn\_iac** bit (bit 23 of the IAC settings register), this block will disable temporarily all IAC action in case the MPX signal exceeds a threshold deviation for a certain period of time.

A higher MPX IAC threshold means a lower overall trigger sensitivity, a higher deviation feed forward factor causes a lower trigger sensitivity at a non zero FM deviation. When the MPX IAC suppression stretch time is increased, the suppression of the MPX signal will last longer after the last pulse detection. Increasing the MPX delay causes that the suppression of the MPX signal begins and ends earlier, relative to the MPX signal itself. In case the sensitivity and feed forward factor are out of range in a certain application, the set point of the AGC can be shifted with parameter AGC set point; this decreases the overall sensitivity of the IAC circuit.

The more often and the longer the MPX signal is suppressed, the more distortion of the audio signal will be the result. In practice, the best setting of the parameters is obtained when the annoying interference pulses are eliminated and when the IAC reacts only little at noise and audio signals. For the TEA6811/6824 tuner, the value codes **\$F4CAED** for the IAC settings register (address \$0FFC) showed a good performance, also on the road.

## IAC testing

The internal trigger is visible on DSP-IO4 (pin 41) if the IAC\_trigger bit of the IAC settings register is set (bit 12). In this mode the parameter settings on the IAC performance can be verified.

The IAC can be tested with the setup given in figure 8.10. The schematics of the interference simulation network (ISN) and the dummy antenna are given in figure 8.11 and 8.12 respectively. The rise time of the pulse generator has to be faster than 5 nanoseconds. The loaded voltage amplitude must be circa 10 Volts. Note that the ISN attenuates the FM signal by circa 20 dB, so the RF signal output of the generator should be compensated for this.

Ignition interference of a four cylinder engine running at 6000 rev/min can be simulated by setting the frequency of the pulse generator at 100 Hz and the duty cycle at 50%. Note that the rising edge as well as the falling edge of the square wave causes a pulse in the RF signal to the receiver. When the IAC is switched off, each 5 milliseconds a pulse can be expected in the audio signal. However, because of the random phase relation between the square wave and the FM signal, the amplitude of the pulses in the audio signal varies and can even be zero.

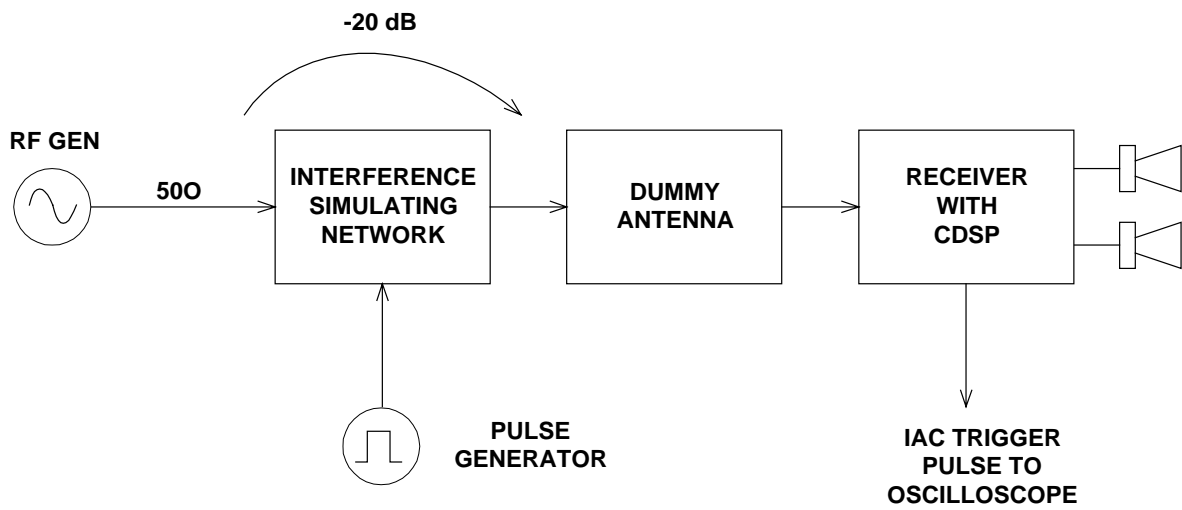

Fig. 8.10 IAC test setup

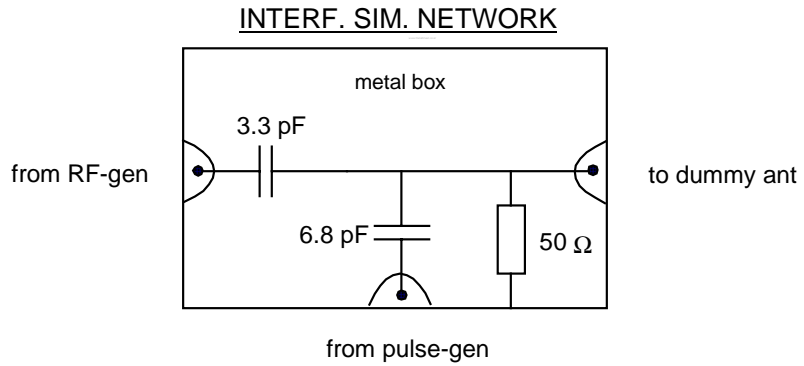

Fig. 8.11 ISN schematics

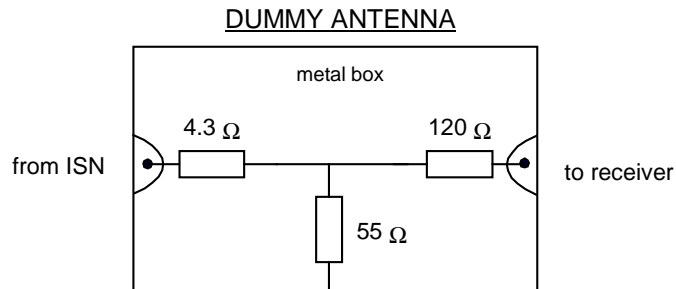

Fig. 8.12 Dummy antenna schematics

## Optimisation procedure IAC parameters

Using the measurement set-up in figure 8.10, the parameters of the IAC can be optimised. (all RF-voltages measured at the input of the dummy antenna. Signal to noise is relative to 22.5 kHz deviation).

The IAC characteristics can be adapted by means of the IAC settings registers. This register contains the control bits that define the IAC parameters. For monitoring the IAC trigger pulse at pin DSP-IO4 (pin 41), bit IAC\_trigger of the IAC settings register (\$0FFC) should be set to 1. See also the datasheet of the SAA7709H.

The complete IAC function can be optimised in three steps :

- 1) Optimise the MPX IAC
- 2) Optimise the Dynamic IAC
- 3) Optimise the Level IAC

### 1. Optimisation of the MPX IAC

Figure 8.13 gives a graphical presentation of the effect that the MPX IAC parameters have on the interference noise and MPX signal. The procedure to optimise the MPX IAC parameters is described below.

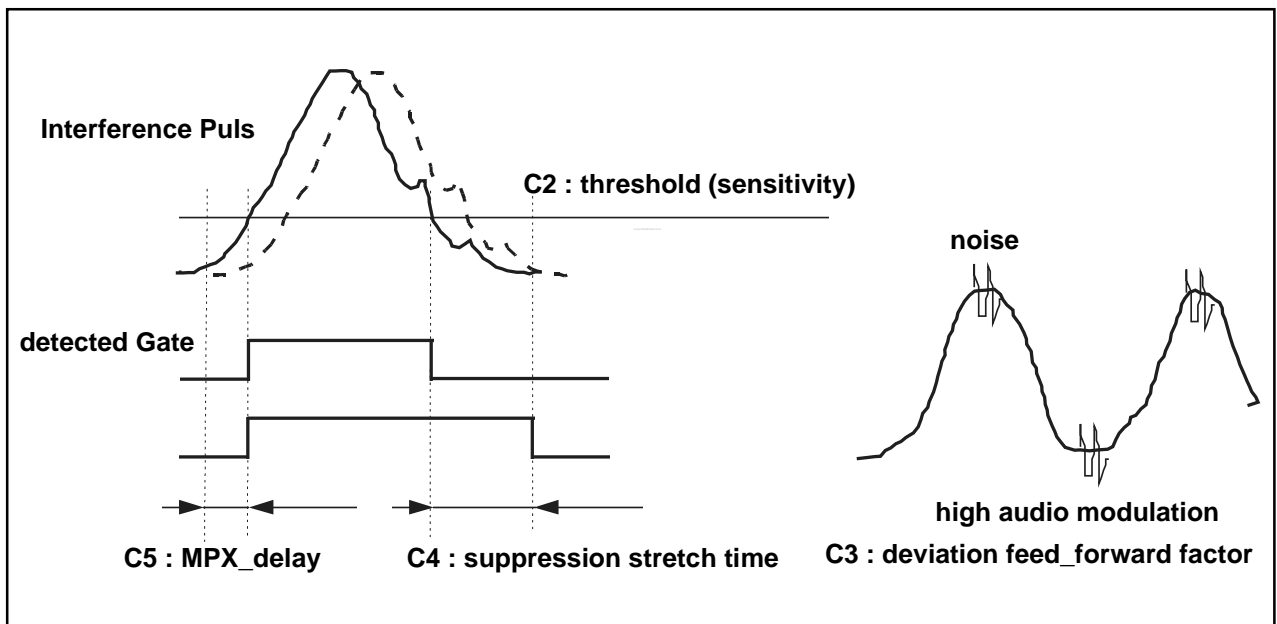

Fig. 8.13 Graphical presentation MPX IAC parameters

Switch OFF the Level IAC and Dynamic IAC functions (set bits 13,14,15,16 and 12 of the IAC settings register \$0FFC to '0').

The optimisation of the MPX IAC can be done by listening, optimise the parameters in the order as given below. Note that the optimisation procedure is iterative, in some circumstances it is needed to re-adjust an already optimised parameter in order to get the overall optimal results.

adjustment of IAC parameter : **Threshold** (sensitivity)

Use no ISN. No modulation. Set **feed\_forward** to minimum (0.00000). By decreasing the RF voltage, the SNR decreases (some sputtering noise can be heard now). Changing **Threshold** causes unwanted trigger pulses. After increasing the RF voltage (which causes also SNR to increase), the unwanted trigger pulses should disappear. Increase of SNR due to unwanted trigger pulses has to be less than 1 dB, this requirement has to be met for any field strength, this can be verified by comparing the audible noise in case of MPX IAC switched ON with the audible noise in case of MPX IAC switched OFF. The audible noise in case of switching ON the MPX IAC should not increase significantly.

adjustment of IAC parameter : **feed\_forward**

Use no ISN. Modulation: fmod=1 kHz, deviation=75 kHz. Choose the RF voltage amplitude so that some trigger pulses occur around the zero crossings of the audio signal. Adjust **feed\_forward** to the value at which the number of unwanted trigger pulses around the peaks of the audio signal is about the same as the number around the zero crossings.

adjustment of IAC parameters **Suppression** and **MPX\_delay**

Use the ISN and create interfering pulses. Make the RF voltage so low that the IAC is still sensitive for pulses. (At lower voltages the IAC will be too sensitive for pulses because of the noise). At this RF voltage, the suppression time is shortest, so the timing of the beginning and the end of the suppression period is most critical. Set **Suppression** and **MPX\_delay** to maximum. The beginning of an interference pulse or maybe the whole pulse is suppressed now. Reduce **MPX\_delay** to the value at which the beginning of the pulse is still just eliminated. Then, reduce **Suppression** so much that the tail of the pulse is just suppressed well. The adjustment of **Suppression** and **MPX\_delay** can be done by listening.

## 2. Optimisation of the Dynamic IAC

The Level IAC function should remain switched OFF; MPX IAC adjusted and switched ON.

adjustment of IAC parameter : **dyn\_threshold**

Use no ISN. Set the RF voltage to 200  $\mu$ V. Modulation: fmod=10 kHz, deviation= 22.5 kHz. First switch OFF the Dynamic IAC. Increase the deviation until the MPX IAC starts (unwanted) triggering. Now switch ON the dynamic IAC and set **dyn\_threshold** to maximum deviation (65 kHz). Adjust (decrease) **dyn\_threshold** to the value at which the unwanted trigger pulses just disappear, now the highest deviation at which no unwanted triggering occurs is achieved.

## 3. Optimisation of the Level IAC

Switch OFF the Dynamic IAC. MPX IAC adjusted and switched ON.

adjustment of IAC parameter : **iac\_threshold**

Use ISN and create interfering pulses. NO modulation. Set **iac\_threshold** to maximum (0.5), **iac\_feed\_forward** to minimum (-2) and **iac\_stretch** to maximum (15). Apply a low RF voltage amplitude such that the MPX IAC stops triggering. Decrease **iac\_threshold** until the Level IAC starts triggering. The sensitivity can be increased by further decreasing **iac\_threshold** but then also false triggering on audio can occur; this can be verified by removing the interfering pulses. Choose **iac\_threshold** such that there is no false triggering and that the Level IAC sensitivity is sufficient at a lower field strength. **It is recommended NOT to set the level IAC threshold lower than 0.05 , otherwise false triggering can occur at certain FM-Level DC values.**

adjustment of IAC parameter : **iac\_feed\_forward** and **iac\_stretch**

Create interfering pulses and verify the audio output signal. Increase **iac\_feed\_forward** to the value at which the beginning of the interfering pulse is still just eliminated. Then, reduce **iac\_stretch** so much that the tail of the pulse is just suppressed well. The adjustment of **iac\_feed\_forward** and **iac\_stretch** can be done by listening.

## 8.4 AM, AUX, Tape, Phone, NAV and CD\_A inputs

From a hardware point of view the input circuits in front of the AD's are the same for these inputs. First the internal input circuit common for the analogue inputs will be discussed here, the specific external components for the different analogue inputs will be discussed in the following sections. The internal input circuit common for the analogue inputs is given in figure 8.14.

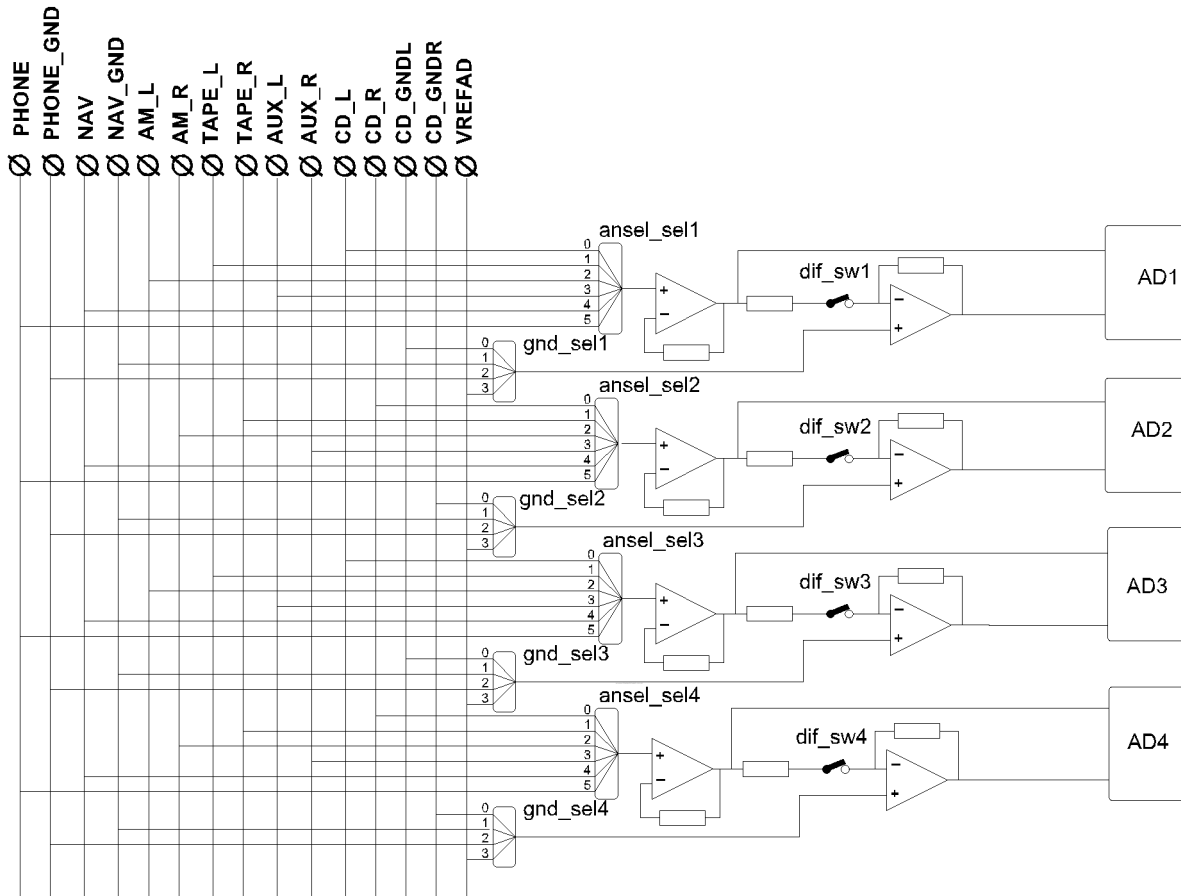

**Fig. 8.14** Input circuit CD\_A / Tape / AM / Phone / NAV / AUX

The switches are controlled via hardware I2C registers with the following bits :

### For ADC1 :

- ◆ ANSEL1 (bits 0, 1 and 2 of register \$0FFA) selects which input source is connected
- ◆ GND\_SEL1 (bits 12 and 13 of register \$0FFA) selects between internal ground (midref) or an external ground (CD\_GNDL, NAV\_GND or PHONE\_GND)
- ◆ DIF\_SW1 (bit 1 of register \$0FF9) selects a High Common Mode or Fully Differential input mode.

### For ADC2 :

- ◆ ANSEL2 (bits 3, 4 and 5 of register \$0FFA) selects which input source is connected
- ◆ GND\_SEL2 (bits 14 and 15 of register \$0FFA) selects between internal ground (midref) or an external ground (CD\_GNDL, NAV\_GND or PHONE\_GND)
- ◆ DIF\_SW2 (bit 2 of register \$0FF9) selects a High Common Mode or Fully Differential input mode.



For ADC3 :

- ◆ ANSEL3 (bits 6, 7 and 8 of register \$0FFA) selects which input source is connected
- ◆ GND\_SEL3 (bits 16 and 17 of register \$0FFA) selects between internal ground (midref) or an external ground (CD\_GNDL, NAV\_GND or PHONE\_GND)
- ◆ DIF\_SW3 (bit 3 of register \$0FF9) selects a High Common Mode or Fully Differential input mode.

For ADC4 :

- ◆ ANSEL4 (bits 9, 10 and 11 of register \$0FFA) selects which input source is connected
- ◆ GND\_SEL4 (bits 18 and 19 of register \$0FFA) selects between internal ground (midref) or an external ground (CD\_GNDL, NAV\_GND or PHONE\_GND)
- ◆ DIF\_SW4 (bit 4 of register \$0FF9) selects a High Common Mode or Fully Differential input mode.

Notes :

1. The input selection related I2C bits are automatically set by the Easy Programming source switching commands as described in chapter 9.0.3.
2. The full scale input level of 660 mVrms at the CD\_A, AUX, NAV, PHONE, Tape and AM inputs corresponds with an input level of 0 dBfs at the input of the DSP.

## 8.4.1 AM inputs

### AM-R/AM\_MONO and AM\_L inputs (pin 66 and pin 67)

The function of the AM inputs can be either :

1. Input for AM mono : AM mono applied to **AM\_R/AM\_MONO** input pin.
2. Input for AM stereo with external AM-stereo decoder : AM left applied to AM-L pin and AM right applied to AM\_R/AM\_MONO input pin.

#### 8.4.1.1 AM inputs for AM-mono mode and AM-stereo mode with external decoder

The basic circuit diagram for the AM-L and AM-R/AM\_MONO input (for AM mono or AM stereo with external stereo decoder is depicted in figure 8.15. The use of the internal ground connection is required for the AM inputs.

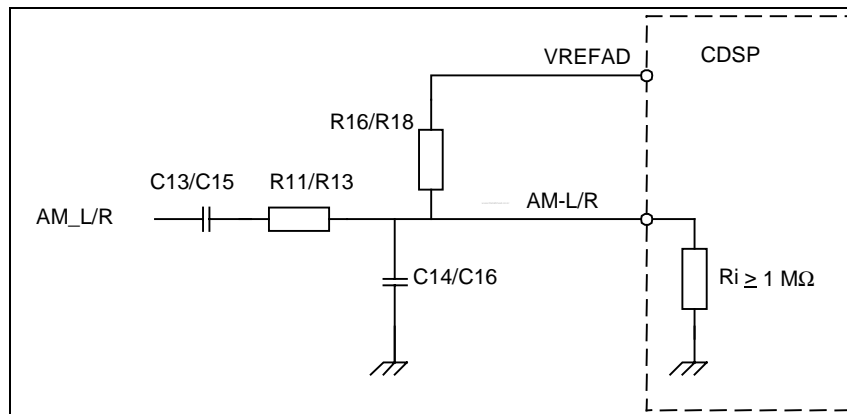

**Fig. 8.15** AM Left/Right input

In case of AM-mono mode the AM-AF output of the tuner has to be connected to the **AM-R/AM** input of the CarDSP, this section deals with both the Left- and Right input because they are identical from a hardware point of view.

The resistor combinations R11 and R16 (or R13 and R18) attenuates the input signal in order to match the AM

output voltage of the tuner to the input range of the A/D convertor. Biasing is done via the resistor R16/R18.

For the CDSP application the AM output voltage of the tuner is assumed to be about 1 Vrms max, R11 and R13 are 100 kΩ, this results in a voltage of 545 mVrms at the AF-AM Left/Right pins of the CDSP.

With R11, C14 and R13, C16 a first order low pass filter is realised at the Left and Right inputs respectively. The cut-off frequency of this filter (Left channel example) is :

$$f_c = \frac{1}{2 \cdot \pi \cdot \frac{R11 \cdot R16}{R11 + R16} \cdot C14}$$

The 1st order filter at the input of the AM Left/Right pins is to avoid aliasing in the Audio A/D convertors, that means that frequency components of  $f > 1/2 f_{sA/D}$  < 88 dB below the maximum input of the A/D convertor (figure for S/N for AM-inputs mentioned in the data sheet).

The requirements are not critical though.

If  $R_{11}/R_{13} = 45 \text{ k}\Omega$  (+/-10%) ,  $R_i = 1 \text{ M}\Omega$  (+/-20%) and  $C_{14}/C_{16} = 100 \text{ pF}$  (+/-10%), then the cut-off frequency  $f_c = 36.9 \text{ kHz}$ .

Remarks:

- a) The source resistance is not taken into account because this  $R_{\text{source}} \ll 220 \text{ K}\Omega$  otherwise the cut-off frequency is affected.
- b) Concerning  $C_{14}/C_{16}$ , X7R SMD capacitors are not allowed because they show some voltage dependency which causes extra distortion, therefore NP0 SMD capacitors are recommended.

The capacitor  $C_{13}/C_{15}$  is applied to block any DC content of the incoming signal. The capacitor  $C_{13}/C_{15}$  forms with  $R_{11}+R_i / R_{13}+R_i$  a high pass filter but there are no critical requirements.

For the CDSP application we use :

$C_{13}/C_{15} = 220\text{nF}$  (+/-10%) and  $R_{in} = 220 \text{ k}\Omega$  (+/-10%), resulting in a  $f_c = 3.3 \text{ Hz}$  (+/-20%).

### **Local oscillator frequency accuracy**

The CQUAM AM-stereo decoder algorithm that runs in the DSP locks and tracks the incoming 9.5 kHz IF signal and allows a maximum tolerance of +/- 250 Hz on the 9.5 kHz IF frequency.

The North American broadcast specification allows for 20 Hz broadcast frequency error, so this leaves a maximum tolerance of +/- 230 Hz for the IF tuner and IF downconverter in front of the SAA7709H.

If for example the IF-mixer inside the AM-stereo tuner has a tolerance of +/- 40 Hz than the maximum tolerance of the local oscillator in fig 8.17 above is 459.5 kHz +/- 190 Hz ; this means that the overall accuracy of the 7.353 MHz Xtal in fig 8.17 is 400 ppm.

## 8.4.2 Tape / AUX input

The TAPE and AUX input can be configured the same. Below there is an example given of the TAPE input.

### TAPE Left / Right (pin 68 and pin 69)

The tape input is for connecting a cassette deck. The basic circuit diagram of the TAPE-L and TAPE-R input is depicted in figure 8.18 ; it is assumed that the internal ground is used for the Tape inputs (single ended inputs).

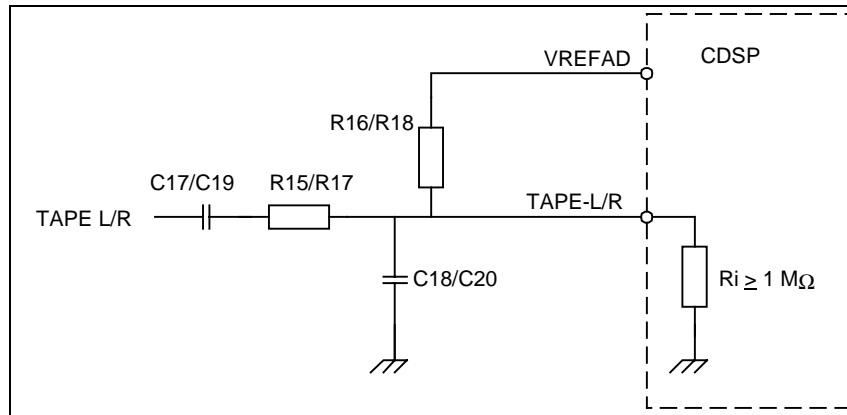

Fig. 8.18 Tape Left/Right input

With  $R15/R17 = 56 \text{ k}\Omega (\pm 10\%)$ ,  $R16/R18 = 100 \text{ k}\Omega (\pm 10\%)$  and  $C18/C20 = 100 \text{ pF} (\pm 10\%)$  a low pass input filter with cut-off frequency  $f_c = 44.3 \text{ kHz}$  is realised.

The capacitor C17/C19 is applied to block any DC content of the incoming signal. The capacitor C17/C19

forms with  $R15+R16 / R17+R18$  a high pass filter but there are no critical requirements.

For the CDSP application we use :

$C17/C19 = 100\text{pF} (\pm 10\%)$  and  $R_{in} = 156 \text{ k}\Omega (\pm 10\%)$ , resulting in a  $f_c = 10.2 \text{ Hz} (\pm 20\%)$ .

Remarks:

- The source resistance is not taken into account because this  $R_{source} \ll 150 \text{ k}\Omega$  otherwise the cut-off frequency is affected.
- The input resistance of the CDSP is not taken into account because this  $R_{in} \geq 1 \text{ M}\Omega$ .
- Concerning C18/C20, X7R SMD capacitors are **not** allowed because they show some voltage dependency which causes extra distortion, therefore NP0 SMD capacitors are recommended.

### 8.4.3 Analogue CD input

#### CD Left/Right and CD-Ground Left/Right (pin 70, 71, 72 and 73)

The analogue CD input is for connecting the analogue output signal of a CD player or CD-changer. The SAA7709H handles fully Differential and/or High Common mode CD players/changers.

#### HIGH COMMON MODE CD PLAYER/CHANGER:

In order to have a high level of common-mode rejection and thus eliminates ground noise it is required to use the external ground (CD\_GNDL and CD\_GNDR) pins. The ground wire of the CD-cable has a separate input at the CDSP in order to realise the required level of Common Mode Rejection Ratio. The basic circuit diagram of the analogue CD-input with High Common Mode inputs is depicted in figure 8.19a.

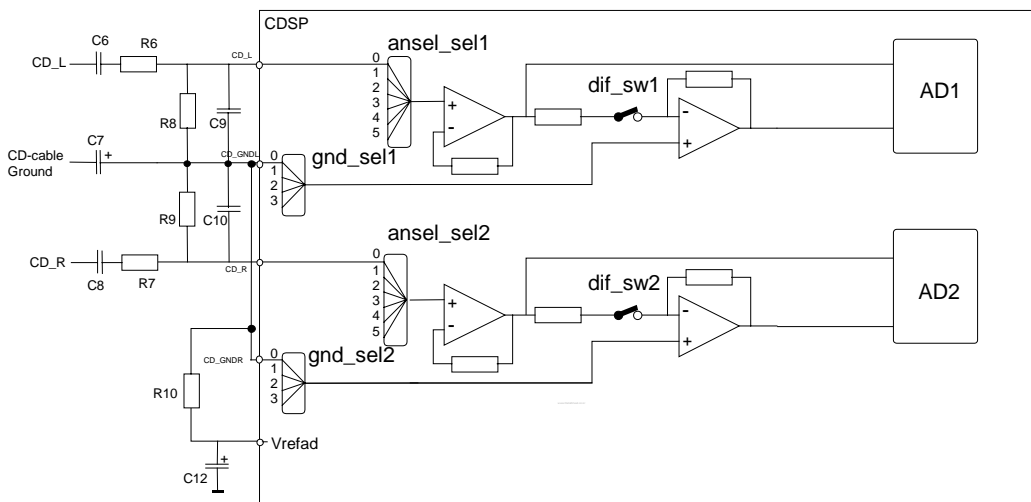

**Fig. 8.19a** High Common Mode Analogue CD input

#### Low pass filter

The filtering of the incoming signal is a first order RC low pass filter realised with the resistors R6, R8 and the capacitor C9 for the Left channel input and with R7, R9 and the capacitor C10 for the Right channel input. The cut-off frequency ( $f_c$ ) of this filter (Left channel) is :

$$f_c = \frac{1}{2 \cdot \pi \cdot \frac{R6 \cdot R8}{R6 + R8} \cdot C9}$$

In the CDSP application we use  $R6 = R7 = 8.2 \text{ k}\Omega (\pm 10\%)$ ,  $R8 = R9 = 10 \text{ k}\Omega (\pm 10\%)$ . In combination with the capacitor  $C9 = C10 = 1 \text{ nF} (\pm 10\%)$ , this results in a cut-off frequency  $f_c = 35 \text{ kHz} (\pm 20\%)$ .

### Variable gain

The gain of the Left- and Right input stages is adjustable and equals  $R8/(R6+R8)$  and  $R9/(R7+R9)$  respectively. The 0 dB output level of the input stage opamps is 0.55 Vrms. In the CDSP application we assume a level of 1 Vrms at the CD-L and CD-R application input.

It is recommended to change the resistor values if a different input gain is required, such that the equivalent parallel resistance  $R3//R4$  and  $R5//R6$  remains  $< 5 \text{ k}\Omega$  for optimal CMRR characteristics.

### Remarks:

- The capacitors C6 and C8 are applied to block any DC content of the incoming signal. The capacitors C6/C8 forms with (R6+R8) and (R7+R9) a high pass filter. The cut-off frequency of this filter must be  $\leq 15 \text{ Hz}$ . With  $R6 = R7 = 8.2 \text{ k}\Omega$  and  $R8 = R9 = 10 \text{ k}\Omega$  this means  $C2, C3 \geq 583 \text{ nF}$ .
- Capacitor C7 is applied to block the DC-bias voltage at the CD-GND pin, in the CDSP application we use  $C7 = 47 \text{ }\mu\text{F}$  ( $\pm 10\%$ ).

### FULLY DIFFERENTIAL PLAYER/CHANGER:

The basic circuit diagram of the analogue CD-input with fully differential inputs is depicted in figure 8.19b.

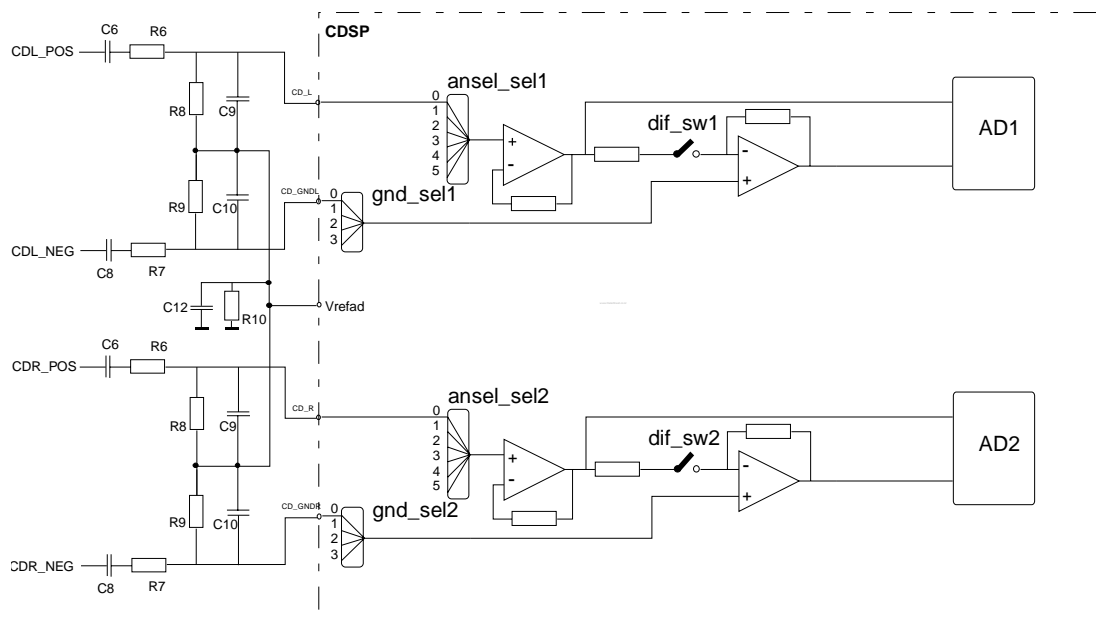

Fig. 8.19b Full Differential Analogue CD input

## Analogue CD input with floating source

In case the signal ground of the CD player is floating (e.g. a battery supplied CD player) the input circuit as given in figure 8.20 does not work due to the high input impedance of the circuit. This problem can be solved by replacing resistor R10 with two diodes connected in anti-parallel, see figure 8.21. Recommended diode types are BAS216 or BAW62.

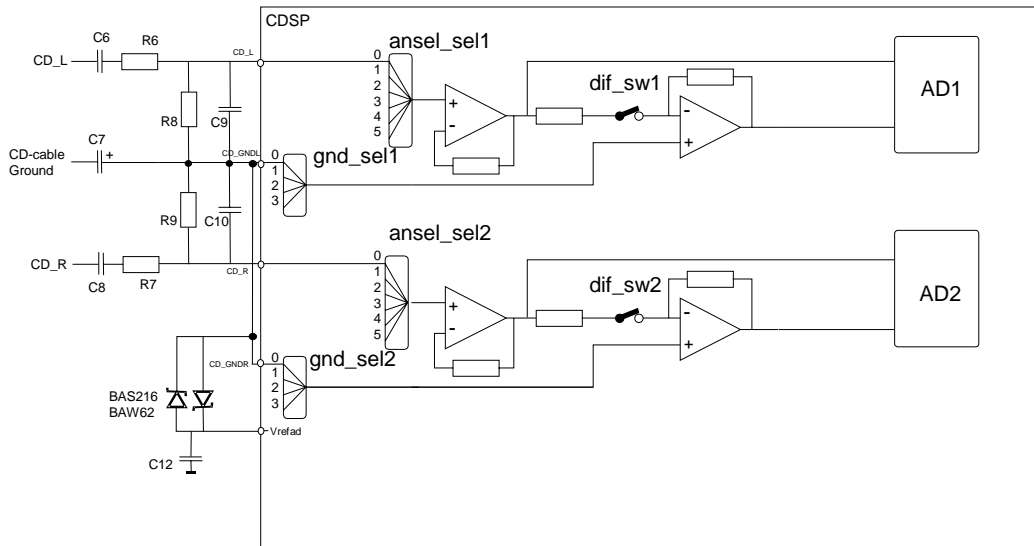
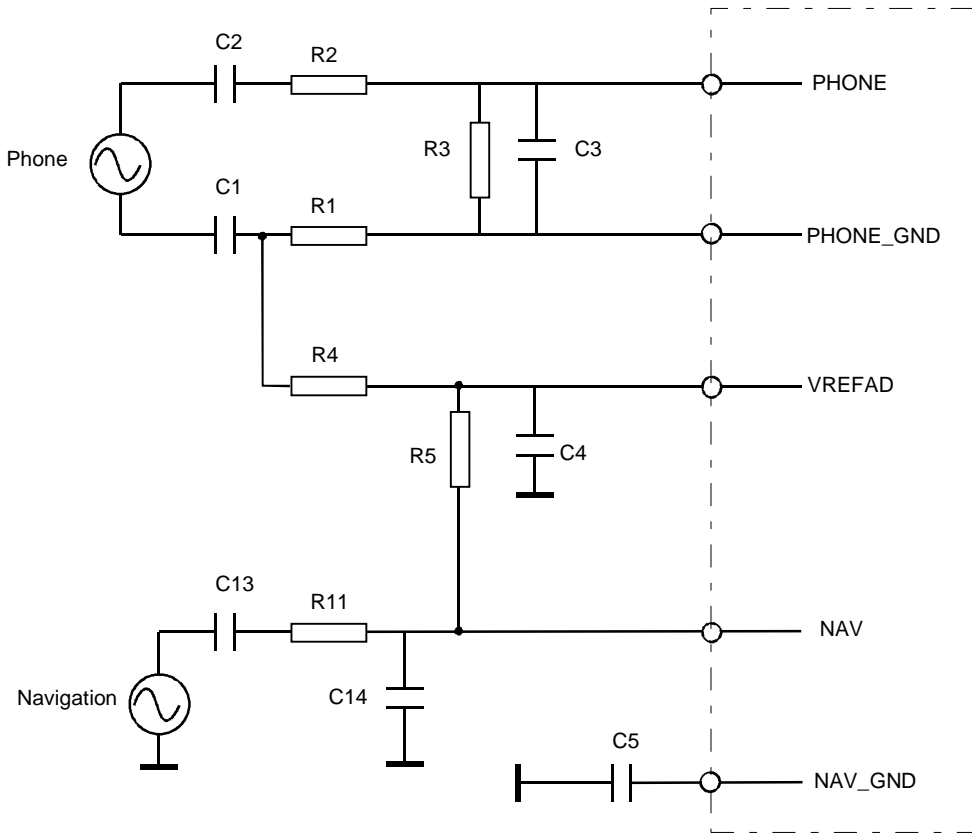

Fig. 8.21 Analogue CD input with floating CD player

## 8.5 Phone and Navigation inputs

The SAA7709H has separate inputs for Phone and Navigation. These inputs have their own ground input therefore several different configurations are possible, such as : Single Ended, High Common Mode and Full Differential Mode. The basic circuit diagram is given in figure 8.22. As example the Phone input is a differential input and the NAV input is single ended.



**Fig. 8.22** Phone and Navigation inputs

The input circuit diagram as given in fig. 8.22 shows that both the Phone and Navigation input have a separate ground input pin. In this case it is assumed that the ground wire Phone input source is connected with the Phone\_GND pin in order to realise a differential input, for the Navigation input it is assumed that the NAV\_GND pin is not used (single ended input) and therefore connected via C5 to ground. It is of course possible to connect the ground wire of the Navigation input source with the NAV\_GND pin, similar as for the Phone input if desired.

The external components of the Phone and Navigation inputs have the following functions :

- Adapt the source signal amplitude to the maximum input voltage of the CDSP
- Input filtering

### Input sensitivity of the Phone input

In the CDSP application we assume that the external phone source delivers a signal of 1 V<sub>rms</sub> maximum.

The full scale input level (0 dB) of the A/D convertor is 660 mV<sub>rms</sub>, the phone source voltage has to be attenuated accordingly.



This results in the equivalent circuit diagram for determining the overall gain of the Phone input. According to the diagram below.

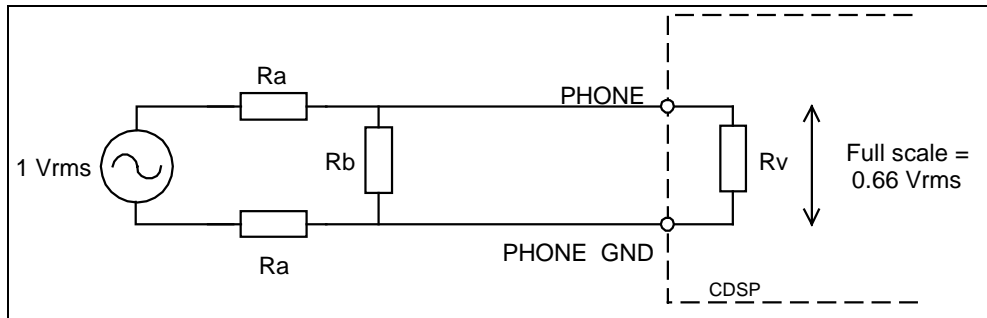

In the CDSP application we use  $R_a=3.9\text{ k}\Omega$  (+/- 1%) and  $R_b=10\text{ k}\Omega$  (+/- 10%);  $R_v=1\text{ M}\Omega$ . Also high impedance inputs are possible. The overall input attenuation is:

$$Att = \frac{(R_b // R_v)}{(R_b // R_v) + 2 * R_a} = 0.65$$

The overall gain of the Phone-input now matches the 1 Vrms phone source to the full scale input level of the A/D converter (=0.66 Vrms).

### CMMR

The CMMR of the Phone input depends on the matching of the internal resistors and the external resistors  $R_1$  and  $R_2$ , for this reason the maximum tolerance of these resistors must be 1% in order to achieve typical 50 dB CMMR as specified in the SAA7709H datasheet.

### Input filtering

The equivalent electrical diagram for determining the Phone input filtering is given in the figure below :  
Low pass filter

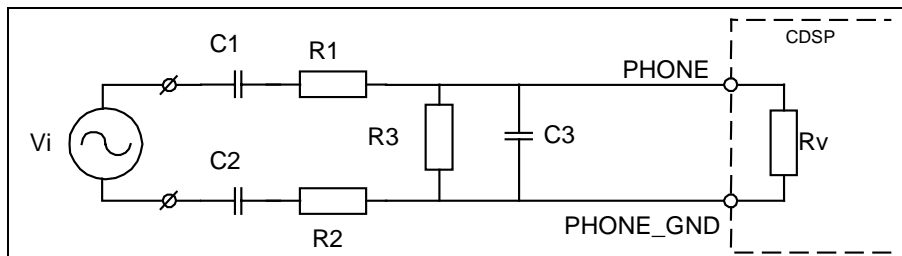

With R1, R2, R3 and C3 a first order low pass filter is realised at the Phone input.  
The cut-off frequency of this filter is :

$$f_c = \frac{1}{2 \cdot \pi \cdot R_i \cdot C_3}$$

$$\text{with } R_i = \frac{(R_1 + R_2) \cdot \frac{R_3 \cdot R_v}{R_3 + R_v}}{(R_1 + R_2) + \frac{R_3 \cdot R_v}{R_3 + R_v}}$$

The 1st order filter at the Phone input is to avoid aliasing in the Audio A/D convertor.  
The requirements are not critical though.

**Remark:** Concerning C59, a X7R SMD capacitor is not allowed because it shows some voltage dependency which causes extra distortion, therefore NP0 SMD capacitors are recommended.

#### High pass filter

The capacitors C1 and C2 are applied to block any DC content of the incoming signal. The capacitors C1 and C2 forms with R1, R2 and R3 a first order high pass filter but there are no critical requirements.  
The cut-off frequency of this filter is :

$$f_c = \frac{1}{2 \cdot \pi \cdot R_h \cdot C_h}$$

$$\text{with } R_h = (R_1 + R_2) + \frac{R_3 \cdot R_v}{R_3 + R_v}$$

$$\text{and } C_h = \frac{C_1 \cdot C_2}{C_1 + C_2}$$

For the CDSP application we use :

### Input sensitivity of the Navigation input

In the CDSP application we assume that the external phone source delivers a signal of 1 Vrms maximum.

The full scale input level (0 dB) of the A/D convertor is 660 mVrms, the Navigation source voltage has to be attenuated accordingly, see figure 8.23.

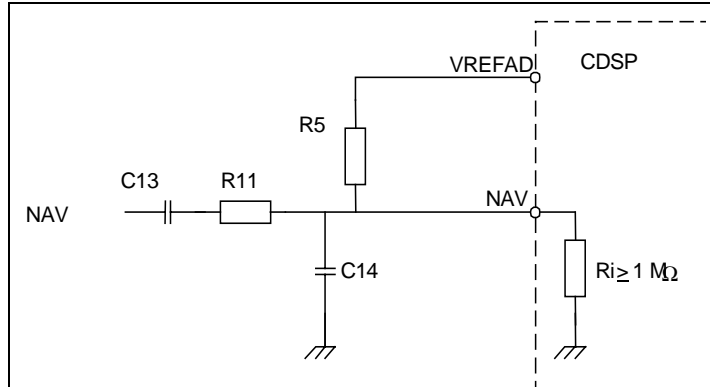

**Fig. 8.23** Navigation input

## 8.6 CD-digital inputs (I2S or SPDIF)

### 8.6.1 General

The DSP runs at the sample frequency of the selected digital input (I2S or SPDIF), supported sample frequencies are 44.1 kHz and 48 kHz ; sample frequency of 32 kHz is **not** supported.

The SAA7709H detects when the selected digital source becomes disconnected for some reason and as a result DSP continues running at 44.1 kHz sampling frequency (derived from Xtal oscillator).

### 8.6.2 I2S input

**I2S inputs** CD-CL (pin 29), CD-WS (pin 27) and CD-DATA (pin 28)

The digital inputs DIGIN is capable of handling multiple input formats (I2S and LSB-justified). If the I2S input pins are not used they must be connected to ground as is indicated in the application diagram. If they are used then in every input line a T-filter can be used, see figure below.

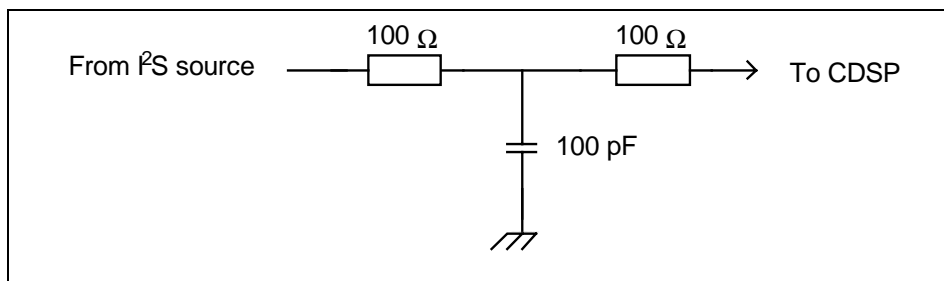

The T-filter is used to avoid incoming and outgoing radiation (component tolerance of the T-filter is  $\pm 20\%$ ). In case the I2S signals come from a device with slew rate controlled outputs, this T-filter might

be unnecessary. Please note that this filter is optimised for a bitrate of  $64 \cdot f_s$  ; the rise- and fall times of the I2S signals will be too high when a higher bitrate is used, in this case the component values of the filter should be adapted in order to compensate for this.

If the I2S driver outputs of the external digital source IC's have Tri-state outputs, they can all be connected on one single I2S input. (not used outputs must be put in the high impedance mode).

## 8.6.3 SPDIF input

### SPDIF inputs SPDIF1 (pin 25) and SPDIF2 (pin 24)

The SPDIF input can be used as an alternative for the I<sup>2</sup>S input. The two SPDIF inputs are connected to the internal SPDIF receiver via an analogue multiplexer (switch) that selects between SPDIF1 and SPDIF2.

The recommended input circuit is given in figure 8.24, see the SAA7709H datasheet for additional information.

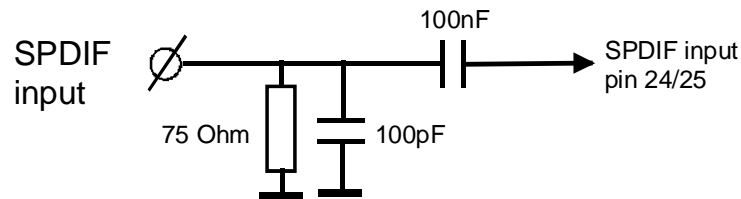

Fig. 8.24 SPDIF input circuit

## 8.7 Radio Data System (RDS) function

### 8.7.1 General description

The RDS function recovers the additional inaudible RDS information which is transmitted by FM radio broadcasting. The operational functions of the demodulator and decoder are in accordance with EBU specification EN 50067.

The RDS function processes the RDS signal that is frequency multiplexed in the stereo-multiplex signal, to recover the information transmitted over the RDS data channel. This processing consists of band-pass filtering, RDS demodulation and RDS/RBDS decoding. Under control of IIC bit `rds_clkin`, an internal buffer can be used to read out the raw RDS stream in bursts of 16 bits. With the IIC-bit `rds_clkout` the RDS clock can be enabled or switched off. The RDS-band signal level in IIC bits `RDS_DET` of register `IIC_RDS_DETECTION` supports fast RDS presence detection.

The RDS band-pass filter discards the audio content from the input signal and reduces the bandwidth. The RDS-band signal level detector removes a possible ARI signal from the RDS band-pass filter output and measures the level of the remaining signal.

The RDS demodulator regenerates the raw RDS bit stream (bit rate = 1187.5 Hz) from the modulated RDS signal in two steps. The first step is the demodulation of the Double-Side-Band Suppressed-Carrier signal around 57 kHz into a baseband signal, by carrier extraction and down-mixing. The second step is the BPSK demodulation of the biphase coded baseband signal, by clock extraction and correlation.

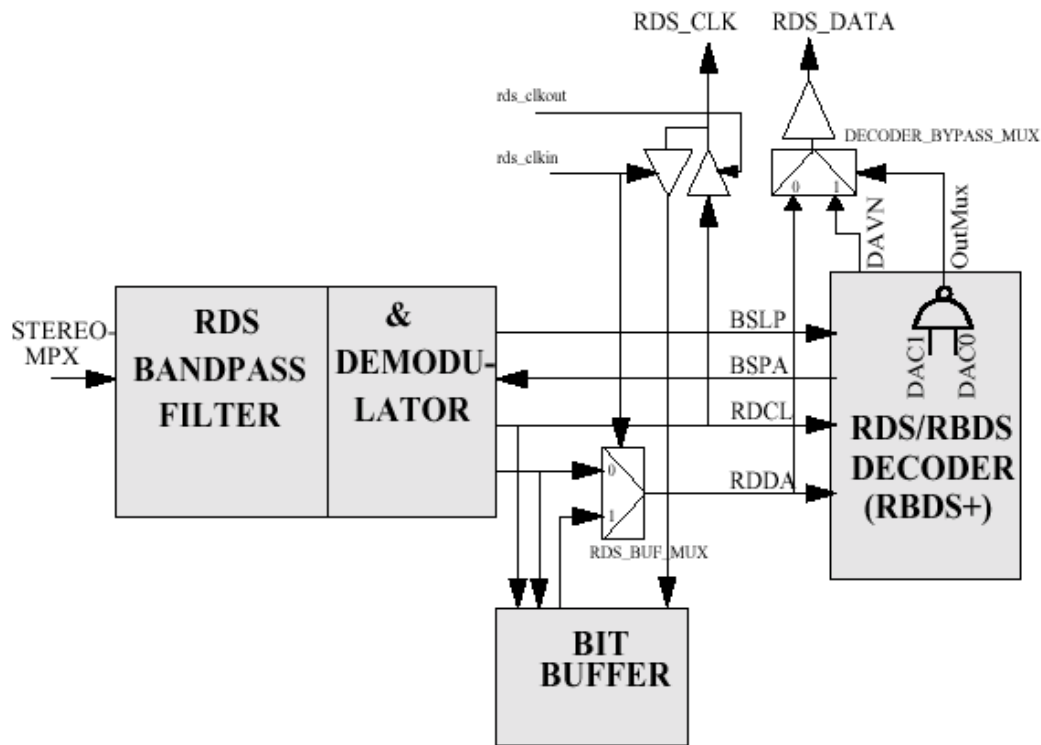

Fig. 8.25 : RDS/RBDS block diagram

The RDS/RBDS decoder provides block synchronization, error detection, error correction, complex flywheel function and programmable block data output. New processed RDS/RBDS block information is signalled to the main microcontroller as “new data available” by use of the DAVN output. The block data itself and the corresponding status information can be read out via IIC-bus request.

### 8.7.2 RDS bandpass filtering

The RDS-chain has a separate input FM\_RDS. This enables RDS updates during tape or other analog source play.

The RDS chain contains a third order sigma-delta AD convertor, followed by two decimation filters. The first filter passes the multiplex band including the signals around 57 kHz and reduces the sigma- delta noise. The second filter reduces the RDS bandwidth around 57 kHz. The overall filter curve is shown in Fig. 8.26 and a more detailed curve of the RDS 57kHz band in Fig. 8.27.

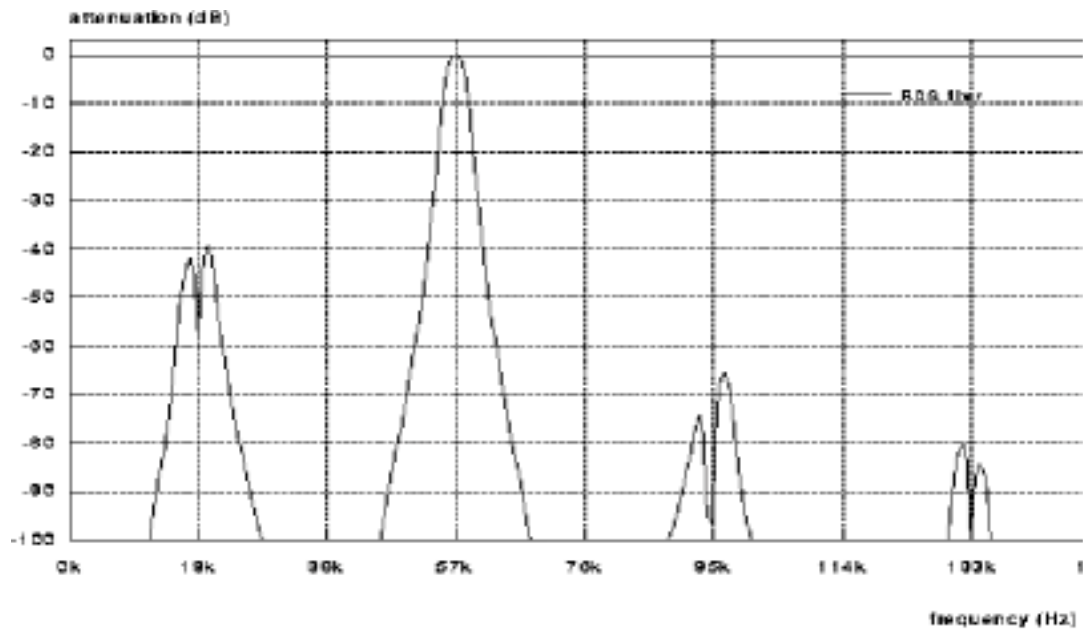

Fig. 8.26 : Overall frequency response curve decimation filters

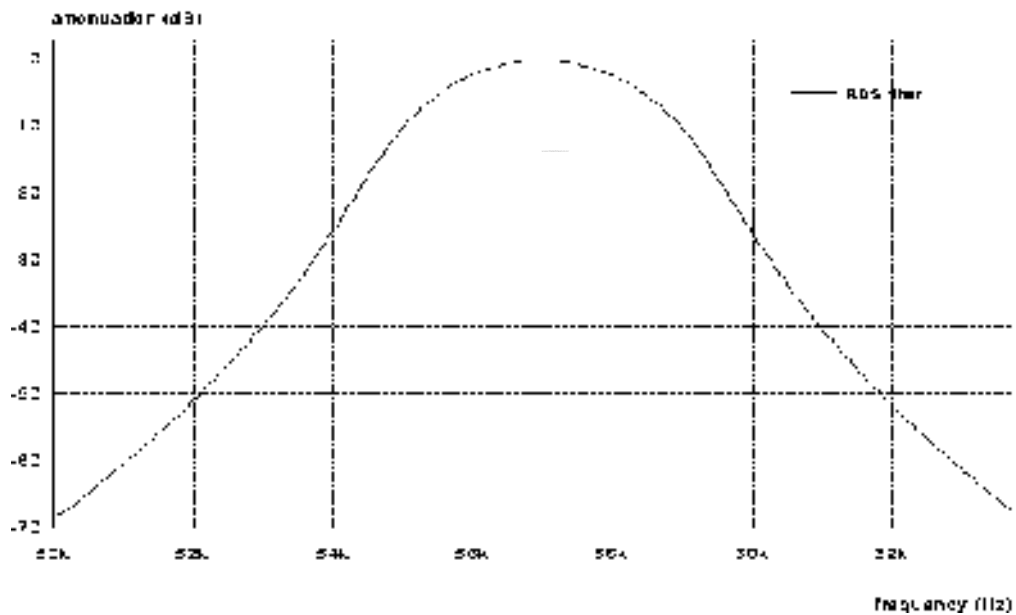

Fig. 8.27 : Detailed frequency response curve RDS channel

In case of FM-stereo reception the clock of the total chip is locked to the stereo pilot (19 kHz multiple). In case of FM-mono the DCS loop keeps the DCS clock around the same 19 kHz multiple. In all other cases like AM reception or tape, the DCS circuit has to be set in a preset position by means of the locked\_preset bit of the IIC\_DCS control register. Under these conditions the RDS system is always clocked by the DCS clock in a 38 kHz ( $4 \times 9.5$  kHz) based sequence.

### 8.7.3 Direct RDS Inputs/outputs in DAVD mode (dac0=1, dac1=1, RDS decoder bypass mode)

Apart from control inputs and data outputs via IIC, the following inputs and outputs are related to the RDS function (see Fig. 8.25).

- Unbuffered raw RDS output mode (rds\_clkin = 0, rds\_clkout = 1)  
RDS\_CLK: Clock of the raw RDS bit stream, extracted from the biphasc coded baseband signal by the RDS demodulator. Clock period 1.1875 kHz (= 8192 clock cycles of the DCS system clock), 50% duty cycle. The positive edge can be used to sample the RDS\_DATA output with.
- RDS\_DATA: Raw RDS bit stream, generated by the demodulator, detection of a positive going edge on the RDCL input signal. The data output is changing 100 ms (= 1/8 of the RDS\_BCK period) after the falling edge of RDS\_BCK. This allows for external receivers of the RDS data to clock the data on the RDS\_BCK signal as well as on its inverse.

Buffered raw RDS output mode (rds\_clkin = 1, rds\_clkout = 0)

- RDS\_CLK: Burst clock, generated by the mP. Bursts of 16 clock cycles are expected. The average time between bursts = 13.5 ms.
- RDS\_DATA: Bursts of 16 raw RDS bits are put out under control of the burst clock input. After a data burst, this output is high. It is pulled low when 16 new bits are available and a new clock burst is awaited. The microprocessor has to monitor this line at least every 13.4 ms.

### 8.7.4 Direct RDS Timing of Clock and Data signals in DAVD mode (dac0=1, dac1=1, RDS decoder bypass mode)

The timing of the Clock and Data output is derived from the incoming data signal. Under stable conditions the data will remain valid for 400 ms after the clock transition. The timing of the data change is 100 ms before a positive clock change. This timing is suited for positive as well as negative triggered interrupts on a microprocessor. The RDS timing is shown in Fig. 8.28.

During poor reception it is possible that faults in phase occur, then the duty cycle of the clock and data signals will vary from minimum 0.5 times to a maximum of 1.5 times the standard clock periods. Normally, faults in phase do not occur on a cyclic basis.

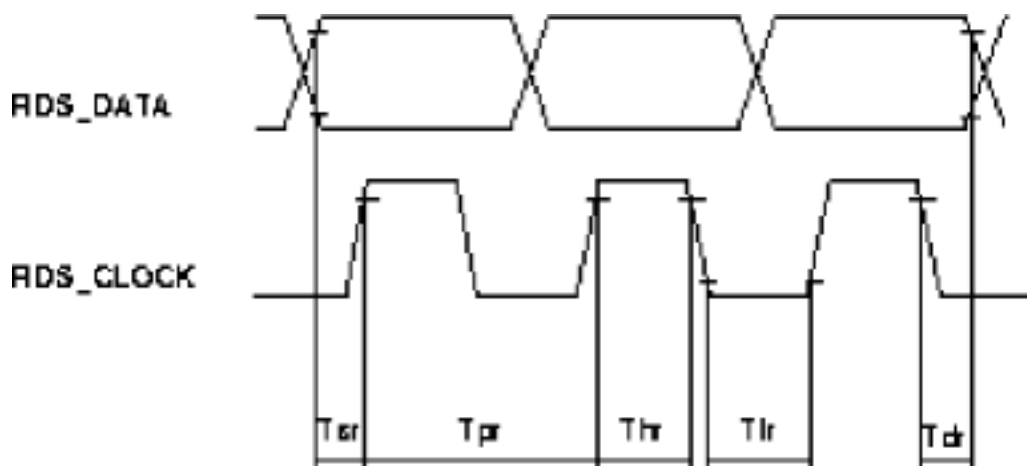

Fig. 8.28 :RDS timing in the direct output mode



### 8.7.5 Buffering of RDS data

The repetition of the RDS data is around the 1187 Hz. This results in an interrupt on the microprocessor for every 842  $\mu$ S. In a second mode, the RDS interface has a double 16 bit buffer.

### 8.7.6 Buffer interface

The RDS interface buffers 16 data bits. Every time 16 bits are received, the data line is pulled down and the buffer is overwritten. The control microprocessor has to monitor the data line in at most every 13.5 msec. This mode is selected by setting the `rds_clkin` IIC bit to "1" and `rds_clkout` to "0" (See "IIC\_RDS\_ConTRol register (\$6005)). In Fig. 8.29 the interface signals from the RDS demodulator and the microcomputer in buffer mode are shown. When the buffer is filled with 16 bit the data line is pulled down. The data line will remain low until reading of the buffer is started by pulling down the clock line. The first bit is clocked out. After 16 clock pulses the reading of the buffer is ready and the data line is set high until the buffer is filled again. The microprocessor stops communication by pulling the line high. The data is written out just after the clock high-low transition. The data is valid when the clock is high.

When a new 16 bit buffer is filled before the other buffer is read, that buffer will be overwritten and the old data is lost.

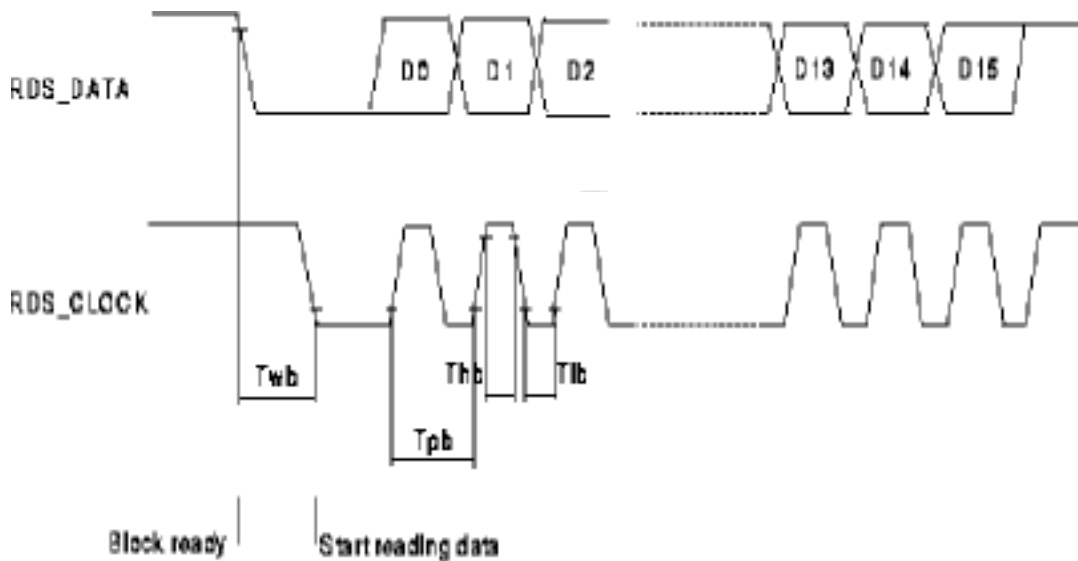

Fig. 8.29 : Interface signals RDS demodulator and microcomputer

The timing figures can be found in Table 8.2.

Table 8.2 : Timing of the RDS

SYMBOL	PARAMETER	CONDITIONS	MIN	TYP	MAX	UNIT	NO
Frdsc1	nominal clock frequency RDS clock		-	1187.5	-	Hz	8.01
Tsr	Clock set-up time		100	-	-	µs	8.02
Tpr	Periodic time		-	842	-	µs	8.03
Thr	Clock high time		220	-	640	µs	8.04
Tir	Clock low time		220	-	640	µs	8.05
Tdr	Data hold time		100	-	-	µs	8.06
Twb	Wait time		1	-	-	µs	8.09
Tpb	Periodic time		2	-	-	µs	8.10
Thb	Clock high time		1	-	-	µs	8.11
Tlb	Clock low time		1	-	-	µs	8.12
Fexcl	input frequency Extern RDS- Clock		-	-	22	MHz	8.13

### 8.7.3 Fast RDS detection with the rds-band signal level detector

RDS presence detection after tuning to a new FM station using only the RDS demodulator/decoder will take 130 mS.

The special for fast RDS detection designed RDS-band signal level detector supports RDS presence detection in 10 ms after the front-end is tuned to the selected frequency.

The band-pass filtered input of the RDS demodulator is first passed through a notch filter to discard a possible ARI signal in the band [57 kHz- 54 Hz, 57 kHz + 54 Hz]. The designed filter has 2 passbands with 3 dB frequencies at 55.4 kHz and 56.6 kHz and at 57.4 kHz and 58.6 kHz respectively. The overall filter characteristic around 57 kHz, from the output of the SRC to the output of the ARI notch, is shown in Fig 8.30 compares the detector filter characteristic with the spectra of RDS signals (deviation = 0.8 kHz) with zero, random, one and toggled messages and the spectrum of an ARI signal (deviation = 7.5 kHz) with worst case subcarriers (SK + DK + BK area F) and with a 12 Hz skew between the centre frequency of the filter and the ARI carrier.

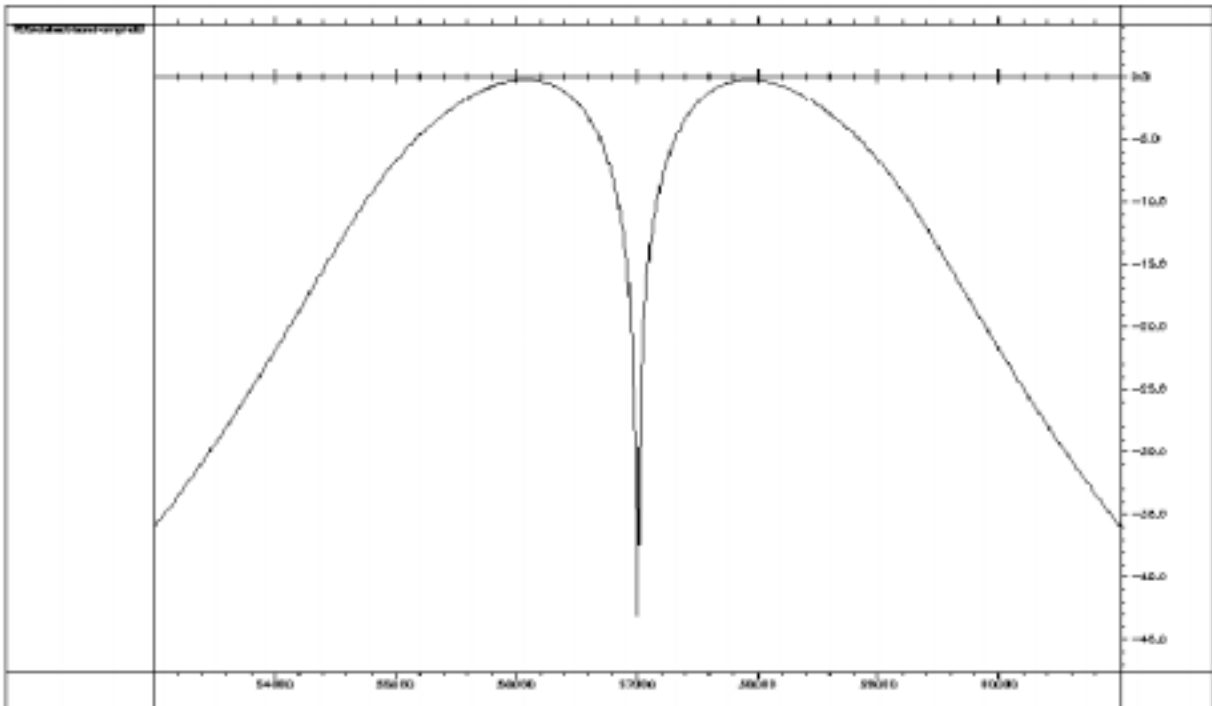

Fig. 8.30 : RDS detector: band-pass filter characteristics

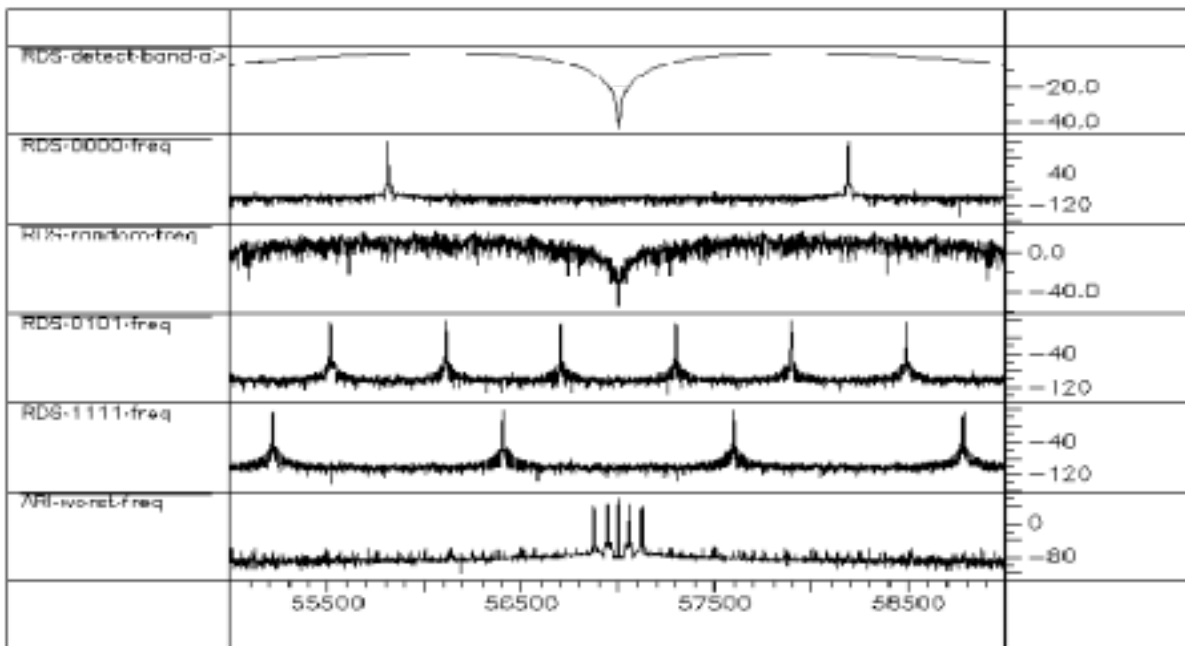

Fig. 8.31 : RDS detector filter versus various signal spectra

The remaining signal is rectified and averaged with a first order low-pass filter with a time constant of 6.75 ms. The output of this filter is a measure for the signal and noise content in the RDS band. The RDS-band signal level in the IIC\_RDS\_DETECTOR register, is an 8-bit unsigned number between 0 and 0.996. For an RDS deviation below 4 kHz, the 8-bit output RDS\_DET is approximately

$$\text{detector output} = \text{RDS\_DET value} = \text{RDS deviation [in kHz]} / 4$$

For all zero or all one messages, the stationary detector output differs approximately 20% from this value. For random messages, the detector output varies between 10% bounds. So,  $RDS\_DET = 0.2 \pm 0.02$  for a deviation of 0.8 kHz,  $0.5 \pm 0.05$  for a deviation of 2.0 kHz in case of random messages. For RDS deviations above 4 kHz, the detector output saturates to the maximum value. Simulations show that the detector output reaches 90% of its stationary value after less than 14 ms. An ARI signal with maximal signal content away from 57 kHz (SK + DK + BK area F and 12 Hz carrier frequency versus filter centre frequency skew) and a deviation of 7.5 kHz, causes a wiggling detector output with maxima below 0.14. If a threshold of 0.18 is used to detect RDS presence, detection takes 12.6 ms for an RDS deviation of 0.8 kHz and 3.4 ms for an RDS deviation of 2.0 kHz.

Fig. 8.32 shows various detector output transients after the selection of the input stereo-MPX signals containing RDS or ARI signals.

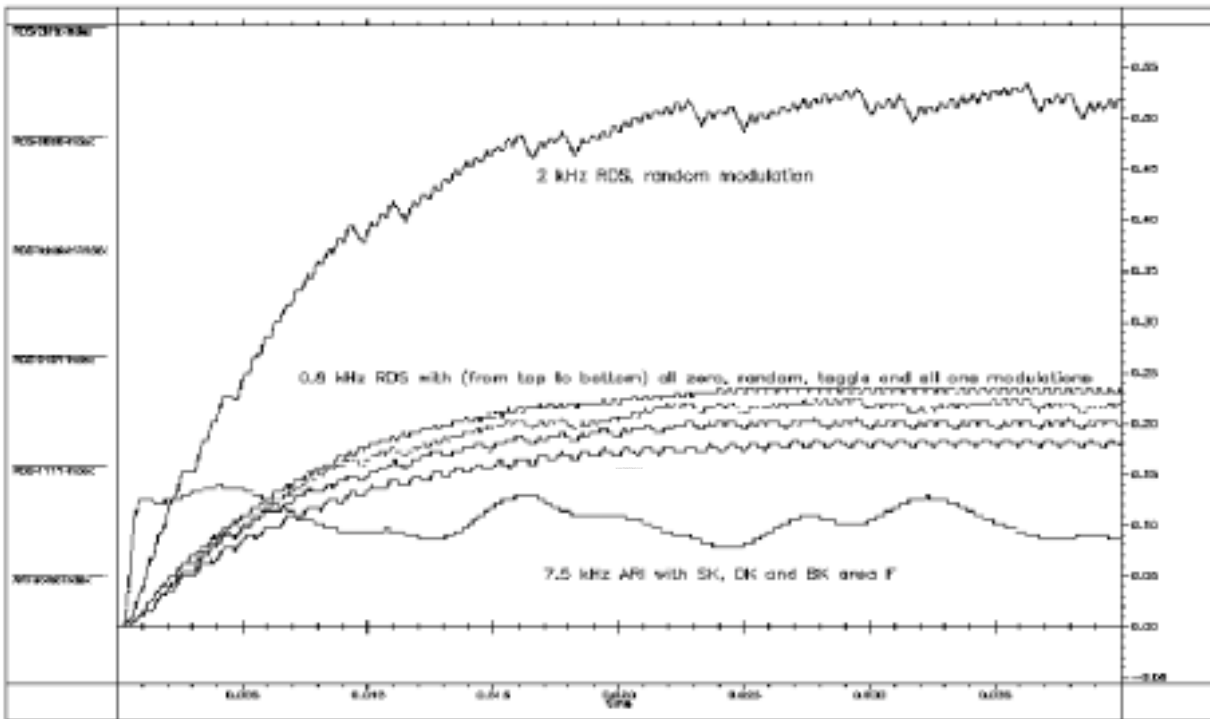

Fig. 8.32 : RDS output for various signals

The noise in the RDS band adds to the detector output. Consider the case of a nominal RDS deviation of 2.0 kHz and white noise measured over the band of the RDS main lobe, i.e. between 54.6 kHz and 59.4 kHz. A noise power of 25 dB below the RDS power level adds 0.043 to the detector output. Every 6 dB more noise doubles the noise contribution to the detector output. A threshold for RDS presence indication can be made dependent on the noise level measured with the wide-band or narrow-band noise detector.

### 8.7.4 Bitflip

Phase jumps of the extracted RDS clock are detected and accumulated. If the accumulated phase shift exceeds a threshold, the RDS/RBDS decoder is informed by the BSLP signal (see Fig. , page ). If the RDS/RBDS decoder detects a bitflip, the RDS demodulator is informed by the BPSA signal. This causes the accumulator of RDS clock phase shifts to be cleared.

### **8.7.5 RDS/RBDS decoder**

The RDS/RBDS decoder handles the complete data processing and decoding of the continuously received serial RDS/RBDS demodulator output data stream (RDDA, RDCL).

Different data processing modes are software controllable by the external main controller via IIC-bus request. All control-signals are direct inputs to the decoder and are connected to the outputs of the IIC memory map interface.

Processed RDS/RBDS data blocks with corresponding decoder status information are available via IIC-bus. Also the output signals of the decoder are direct outputs and are connected to the inputs of the IIC-bus memory map interface.

As already mentioned, the RDS/RBDS decoder contains the following functions.

- RDS and RBDS block detection
- Error detection and correction
- Fast block synchronization
- Synchronization control (flywheel)
- Mode control for RDS/RBDS processing
- Different RDS/RBDS block information output modes (e.g. A / C' block output mode)

The functions which are realized in the decoder are described in detail within the next sections.

### 8.7.6 RDS/RBDS block detection

The RDS/RBDS block detection is always active.

For a received sequence of 26 data bits a valid block and corresponding offset are identified via syndrome calculation.

During synchronization search, the syndrome is calculated with every new received data bit (bit-by-bit) for a received 26-bit sequence. If the decoder is synchronized, syndrome calculation is activated only after 26 data bits for each new block received.

Under RBDS reception situation, besides the RDS block sequences with (A, B, C/C', D) offset also block sequences of 4 blocks with offset E may be received. If the decoder detects an 'E- block', this block is marked in the block identification number (BINr<2:0>) and is available via IIC-bus request. In RBDS processing mode the block is signalled as valid 'E-block' and in RDS processing mode, where only RDS blocks are expected, signalled as invalid 'E-block'.

This information can be used by the main controller to detect 'E-block' sequences and identify RDS or RBDS transmitter stations.

### 8.7.7 Error detection and correction

The RDS/RBDS error detection and correction recognizes and corrects potential transmission errors within a received block via parity-check in consideration of the offset word of the expected block. Burst errors with a maximum length of 5 bits are corrected with this method.

After synchronization has been found the error correction is always active depending on the pre-selected 'error correction mode for synchronization' (mode SYNCA... SYNCD), but cannot be carried out in every reception situation.

During synchronization search, the error correction is disabled for detection of the first block and is enabled for processing of the second block depending on the pre-selected 'error correction mode for synchronization' (mode SYNCA... SYNCD).

The processed block data and the status of error correction are available for data request via IIC- bus for the last two blocks.

Table 8.3 :RDS processed error correction

EXB1	EXB0	DESCRIPTION
0	0	no errors detected
0	1	burst error of max. 2 bits corrected
1	0	burst error of max. 5 bits corrected
1	1	uncorrectable block

Processed blocks are characterized as uncorrectable under the following conditions:

- During synchronization search, if the burst error (for the second block) is higher than allowed by the pre-selected correction mode SYNCA... SYNCD.

- After synchronization has been found, if the burst error exceeds the correctable max. 5 bit burst error or if errors are detected but error correction is not possible.

### 8.7.8 Synchronization

The decoder is synchronized if two valid blocks in a valid sequence are detected by the block detection. The search for the first block is done by a bit-by-bit syndrome calculation, starting after the first 26 bits have been received. This bit-by-bit syndrome calculation is carried out until the first valid and error free block has been received. Then the next expected block is calculated and syndrome calculation is done after the next 26 bits have been received. The block-span in which the second valid and expected block can be received is selectable via previously setting of the Max\_Bad\_Blocks\_Gain (MBBG<4:0>). If the second received block is an invalid block, then the bad\_blocks\_counter is incremented and again the new next expected block is calculated. If the bad\_blocks\_counter value reaches the pre-selected Max\_Bad\_Blocks\_Gain, then the bit-by-bit search for the first block is started again. If synchronization is found, the synchronization status flag (SYNC) is set and available via IIC- bus request. The synchronization is held until the bad\_blocks\_counter value reaches the pre-selected Max\_Bad\_Blocks\_Lose value (used for synchronization hold) or an external restart of synchronization is performed (NWSY=1; or power-on reset).

### 8.7.9 Flywheel for synchronization hold

For a fast detection of loss of synchronization an internal flywheel is implemented. Therefore one counter (bad\_blocks\_counter) checks the number of uncorrectable blocks and a second counter (good\_blocks\_counter) checks the number of error free or correctable blocks. Error blocks increment the bad\_blocks\_counter and valid blocks increment the good\_blocks\_counter. If the counter value of the good\_blocks\_counter reaches the pre-selected Max\_Good\_Blocks\_Lose value (MGBL<5:0>) then good\_blocks\_counter and bad\_blocks\_counter are reset to zero. But if the bad\_blocks\_counter reaches the pre-selected Max\_Bad\_Blocks\_Lose value (MBBL<5:0>) then new synchronization search (bit-by-bit) is started (SYNC=0) and both counters are reset to zero.

The flywheel function is only activated if the decoder is synchronized. The synchronization is held until the bad\_blocks\_counter reaches the pre-selected Max\_Bad\_Blocks\_Lose value (loss of synchronization) or an external forced start of new synchronization search (NWSY=1) is performed. The maximum values for the flywheel counters are both adjustable via IIC-bus in a range of 0 to 63.

### 8.7.10 Bit slip correction

During poor reception situation phase shifts of one bit to the left or right (-1 bit slip) between the RDS/RBDS clock and data may occur, depending on the lock conditions of the demodulators clock regeneration.

If the decoder is synchronized and detects a bit slip (BSLP=1), the synchronization is corrected by +1, 0 or -1 bit via block detection on the respectively shifted expected new block.

### 8.7.11 Data processing control

The decoder provides different operating modes selectable by NWSY, SYM0, SYM1, DAC0 and DAC1 inputs via the external IIC-bus. The data processing control performs the pre-selected operating modes and controls the requested output of the RDS/RBDS information.

### 8.7.12 Restart of synchronization mode:

The 'restart synchronization' (NWSY) control mode immediately terminates the actual synchronization and restarts a new synchronization search procedure (NWSY=1). The NWSY flag is automatically reset after the restart of synchronization by the decoder.

This mode is required for a fast new synchronization on the RDS/RBDS data from a new transmitter station if the tuning frequency is changed by the radio set.

Restart of synchronization search is furthermore automatically carried out if the internal flywheel signals a loss of synchronization.

### 8.7.13 Error correction control mode for synchronization:

For error correction and identification of valid blocks during synchronization search as well as synchronization hold, four different modes are selectable (SYM1, SYM0).

- mode SYNCA (SYM0=0, SYM1=0): no error correction; blocks detected as correctable are treated as invalid blocks, internal bad\_blocks\_counter still incremented even if correctable errors detected. If synchronized only error free blocks increment the good\_blocks\_counter. All blocks except error free blocks increment the bad\_blocks\_counter.
- mode SYNCB: (SYM0=1, SYM1=0) error correction of burst error max. 2 bits; blocks corrected are treated as valid blocks, all other errors detected are treated as invalid blocks. If synchronized error free and correctable max. 2 bit errors increment the good\_blocks\_counter.
- mode SYNCC: (SYM0=0, SYM1=1) error correction of burst error max. 5 bits; blocks corrected are treated as valid blocks, all other errors detected are treated as invalid blocks. If synchronized error free and correctable max. 5 bit errors increment the good\_blocks\_counter.
- mode SYNCD: (SYM0=1, SYM1=1) no error correction; blocks detected as correctable are treated as invalid blocks if in synchronization search mode. Internal bad\_block\_counter is always incremented even if correctable errors detected. If synchronized error free blocks and correctable max. 5 bit errors increment the good\_blocks\_counter. Only uncorrectable blocks increment the bad\_blocks\_counter.

### 8.7.14 RBDS processing mode:

The decoder is suitable for receivers intended for the European (RDS) as well as for the USA (RBDS) standard. If RBDS mode is selected (RBDS=1) via the IIC-bus, the block detection and the error detection and correction are adjusted to RBDS data processing. That is, also E blocks are treated as valid blocks. If RBDS is reset to zero (0), RDS mode is selected.



### 8.7.15 Data available control modes:

The decoder provides three different RDS/RBDS data output processing modes plus one decoder bypass mode selectable via the 'data available' control mode inputs DAC0 and DAC1.

Table 8.4 : DAV modes

mode DAVA: (DAC0=0, DAC1=0)	Standard output mode: If the decoder is synchronized and a new block is received (every 26 bits), the actual RDS/RBDS information of the last two blocks is available with every new received block (approx. every 21.9ms).
mode DAVB: (DAC0=1, DAC1=0)	Fast PI search mode: During synchronization search and if a new A or C' block is received, the actual RDS/RBDS information of this or the last two A or C' blocks respectively is available with every new received A or C' block. If the decoder is synchronized, the "standard output mode" is active.
mode DAVC: (DAC0=0, DAC1=1)	Reduced data request output mode: If the decoder is synchronized and two new blocks are received (every 52 bits), the actual RDS/RBDS information of the last two blocks is available with every two new received blocks (approx. every 43.8ms).
mode DAVD: (DAC0=1, DAC1=1)	Decoder bypassed mode: If this mode is selected then the OutMux output of the decoder is reset to low (OutMux=0). Then the internal row buffer output is active and the decoder is bypassed.

The decoder provides: data output of the block-identification of the last and previously processed blocks, the RDS/RBDS information words and error detection / correction status of the last two blocks as well as general decoder status information.

In addition the decoder output is controlled indirectly by the data request from the external main controller. The decoder receives a 'data overflow' (DOFL) signal controlled by the IIC-bus register-interface. This DOFL is set to high (DOFL=1) if the decoder is synchronized and a new RDS/RBDS block is received before the previously processed block was completely transmitted via IIC-bus. After detection of data overflow the interface-registers are not updated until reset of the data overflow flag (DOFL=0) by reading via the IIC-bus or if NWSY=1 which results in start of new synchronization search (SYNC=0).

### 8.7.16 Data output of RDS/RBDS information

The decoded RDS/RBDS block information and the current decoder status is available via the IIC-bus. For synchronization of data request between main controller and decoder the additional data available output (DAVN) is used.

If the decoder has processed new information for the main controller the data available signal (DAVN) is activated (low) under the following conditions:

During synchronization search in DAVB mode if a valid A or C' block has been detected. This mode can be used for fast search tuning (detection and comparison of the PI code contained in the A and C' blocks).

During synchronization search in any DAV mode except DAVD mode, if two blocks in the correct sequence have been detected (synchronization criterion fulfilled).

If the decoder is synchronized and in mode DAVA and DAVB a new block has been processed. This mode is the If the decoder is synchronized.

If the decoder is synchronized and in DAVC mode two new blocks have been processed.

If the decoder is synchronized and in any DAV mode except DAVD mode loss of synchronization is detected (flywheel loss of synchronization, resulting in restart of synchronization search).

In any DAV mode except DAVD mode, if a reset caused by power-on or voltage-drop is detected. Remark: If the decoder is synchronized, the DAVN signal is always activated after 21.9ms in DAVA or DAVB mode and after 43.8 ms in DAVC mode independent of valid or invalid blocks are received.

The processed RDS/RBDS data are available for IIC-bus request for at least 20 ms after the DAVN signal was activated. The DAVN signal is always automatically de-activated (high) after ~10 ms or almost immediately after the main controller has read the RDS/RBDS status byte via IIC-bus (see DAVN timing).

The decoder ignores new processed RDS/RBDS blocks if the DAVN signal is active or if data overflow occurs (DOFL=1).

The following tables show the block identification number and processed error status outputs of the decoder and how to interpret the output data.

RDS block identification number

BLNR<2>	BLNR<1>	BLNR<0>	BLOCK IDENTIFICATION
0	0	0	block A
0	0	1	block B
0	1	0	block C
0	1	1	block D
1	0	0	block C'
1	0	1	block E (RBDS mode)
1	1	0	invalid block E (RDS mode)
1	1	1	invalid block

RDS processed error correction

EXB1	EXB0	DESCRIPTION
0	0	no errors detected
0	1	burst error of max. 2 bits corrected
1	0	burst error of max. 5 bits corrected
1	1	uncorrectable block

## 8.8 Interface with Tuner TEA6840 (NICE)

The tuner IC TEA6840 allows for a fast RDS update sequence of about 7ms. The IC has an RDS update timing sequencer on board which performs the following tasks:

- Mute of the FM-MPX signal with a slope of 1 ms for fade out and fade in of the MPX signal
- Tuning to the alternative frequency and back to the main frequency
- generating of two timing signals AFHold and AFSample to control the CDSP

Figure 8.33 shows the interface diagram between Tuner and CDSP and figure 8.34 the timing diagram. The TEA6840 delivers two MPX signals to the CDSP, one with Mute, the FMMPX and one without Mute, the RDSMPX. The RDSMPX signal enables the possibility to take also a Noise sample X:NOISFLT\_U from the alternative frequency. This is realised by switching the input of the A/D converter from FMMPX to RDSMPX during the RDS update with SEL\_FR. An internal mute in the CDSP is initiated with AFSample to suppress the modulation from the RDSMPX signal.

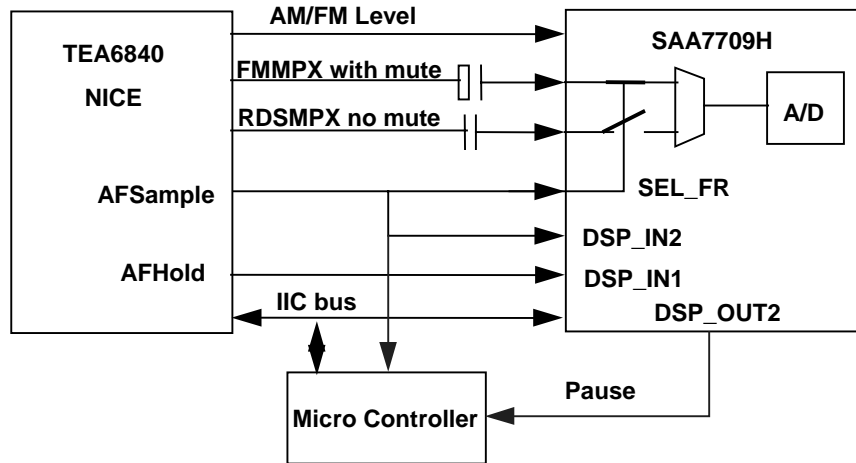

Figure 8.33 : Interface diagram between Tuner TEA6840 and CDSP

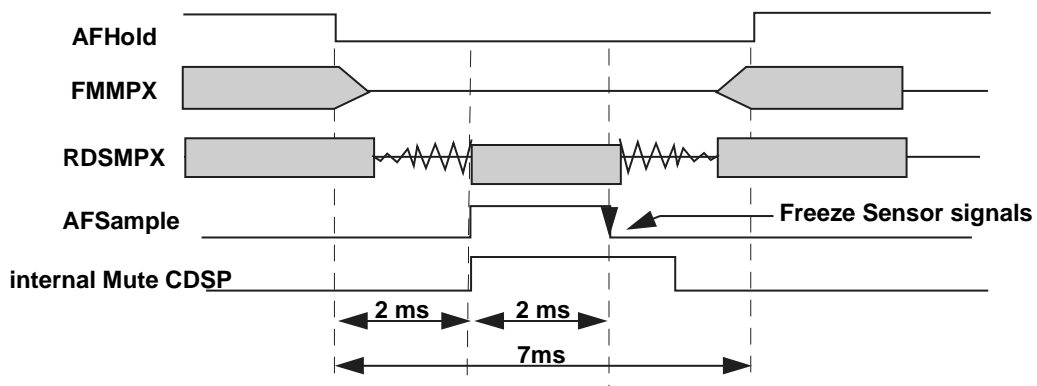

Figure 8.34 : Timing diagram RDS update with TEA6840

**Remark:** Due to the fast update the allowed settling time for the sensors is very short, about 2ms. In this time the sampled sensor values are not fully stabilised. Therefore the values taken during an update for X:LEVA\_U and X:NOISFLT can differ slightly (+/- 3dB) from the real values. The multipath value X:MLTFLIM\_U is not reliable after a jump from a frequency with high fieldstrength to a frequency with low fieldstrength.

## 8.9 I2C interface

### SCL (pin 57), SDA (pin 58)

These two pins needs a RC filter in the input/output lines for EMC reasons, as is indicated in the application diagram. The components are not critical so a tolerance of 20% is tolerable.

## 8.10 Second processor extension function

For communication with external processors, delay lines or other I<sup>2</sup>S controllable devices a complete dual channel 18 bit output bus is implemented. The CDSP is acting as the master transmitter and the external device has to be synchronised with the word select line. As input for the processed data two data input lines have been implemented which are processed synchronously with the data output to the external processor. This enables in total a feedback of two stereo audio channels.

To the external processor, the DSP program should move data to the two Ext IIS DATA output registers, and read it back from the two or four Ext IIS DATA 1/2 input registers. The hardware of the bus can be enabled/disabled with bit 11 (`en_host_io`) of the Selector registers (address \$0FF9), by default the I2S outputs are disabled. To minimise EMC, the output has to be disabled (= default) in case the output is not used.

I2S input/outputs: IIS\_IN1 (pin 31), IIS\_IN2 (pin 32), IIS\_OUT1 (pin34), IIS\_OUT2 (pin 35),  
IIS\_CLK (pin 30), IIS\_WS (pin33)

## 8.11 Digital subwoofer and center output

The CDSP offers an additional dual channel 18 bit digital output for the use of a subwoofer and center output. A choice can be made between Ext. DAC outputs, IIS-OUT1 and IIS-OUT2 for the subwoofer and center output.

Similar as the second processor extension function, the digital subwoofer output is capable of generating multiple output formats (I2S and LSB justified data formats). It is however not possible to select different data formats for the second processor and the subwoofer output.

As also mentioned for the second processor outputs, the hardware of the bus can be enabled/disabled with the `en_host_io` bit in register \$0FF9.

To minimise EMC, the output has to be disabled (= default) in case the output is not used.

I2S outputs: IIS\_OUT1 (pin 34) or IIS\_OUT2 (pin 35),  
IIS\_CLK (pin 30) and IIS\_WS (pin33)

## 8.12 External DAC output (subwoofer)

The SAA7709H consists over I2S outputs that could be connected to an external DAC with a own clock (`FS_SYS`). This external DAC could be applied to convert the digital subwoofer/center signal to an audible signal.

The External DAC output can be enabled/disabled with bit 15 (`en_dac_out`) of the Selector registers (address \$0FF9), by default the external DAC output is disabled. To minimise EMC, the output has to be disabled (= default) in case the output is not used.

The UDA1320 or UDA1330 (Filter stream DAC) can be applied to convert the digital subwoofer and center signal, this DAC type is compatible with the 3.3V output levels of the SAA7709H.

## 8.13 X-tal oscillator circuit

### OSC\_IN and OSC\_OUT (pin 63 and pin 64)

The on chip crystal oscillator is a Pierce oscillator and is described in the data sheet.

The crystal is running in fundamental mode on 11.2896 MHz. Although a multiple of the crystal frequency falls within the FM reception band, this will not influence the reception because the crystal is driven in a controlled way.

The crystal oscillator circuit can operate both in master mode and in slave mode.

The blockdiagram of the X-tal oscillator circuit in master mode is depicted in figure 8.25.

The active element Gm compensates for the loss resistance of the crystal. The AGC circuit controls the gain of the oscillator and prevents clipping of the generated sine-wave and therefor minimises the higher harmonics. The blockdiagram of the X-tal oscillator circuit in slave mode is depicted in figure 8.26.

In order to minimise feedback due to ground bounce the power supply connections of the crystal oscillator circuit are separated from the other power supply lines.

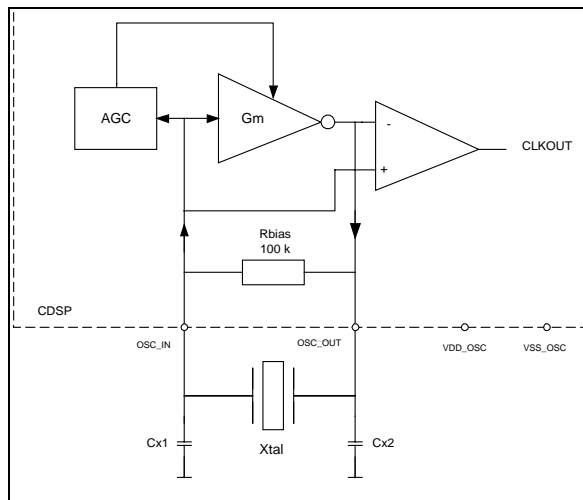

**Fig. 8.25** Block diagram oscillator in master mode

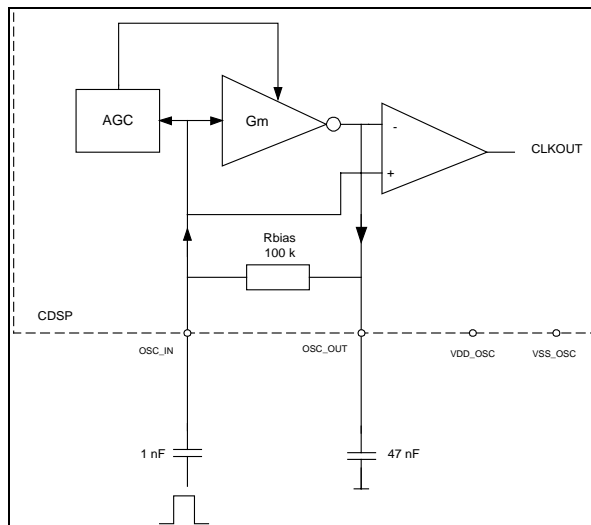

**Fig. 8.26** Block diagram oscillator in slave mode

## X-tal calculations

It can be shown that in order to start-up the transconductance of the active element must have a certain value  $g_{m,A}$

$$g_{m,A} = 4\omega^2 R C_L^2$$

Where R is the loss resistance of the crystal and  $C_L$  is the load capacitance:

$$C_L = \frac{C_{x1} \cdot C_{x2}}{C_{x1} + C_{x2}} + C_p$$

$C_{x1}$  and  $C_{x2}$  are the capacitors connected to either side of the crystal and  $C_p$  is the parasitic shunt capacitance of the crystal.

In the CDSP the minimum transconductance is 4 mA/V. In order to ensure start-up, the following inequality must hold:

$$\omega^2 \cdot R \cdot C_L^2 < \frac{g_{m,\min}}{4}$$

Filling in the oscillation frequency of the CDSP ( $f_0 = 11.2896\text{MHz}$ ) and  $g_{m,\min}$  one obtains:

$$R C_L^2 < 1.99 \cdot 10^{-19}$$

For example, if  $C_{x1} = C_{x2} = 18\text{pF}$  and  $C_p = 5\text{pF}$  so that  $C_L = 14\text{pF}$ , the loss resistance R of the crystal must be smaller than  $1000 \Omega$ . However it is wise to take a safety margin of 30% because the above equations are approximations. In this example that would mean that the maximum loss resistance of the crystal (which is specified by the manufacturer) should not exceed  $80 \Omega$ .

The internal bias resistor  $R_{\text{bias}}$  is chosen high enough ( $100 \text{k}\Omega$ ) in order to prevent start-up problems. A safe value for  $R_{\text{bias}}$  is

$$R_{\text{bias}} \gg \frac{1}{\omega_0^2 R_s \cdot C_p^2}$$

where  $\omega_0$  is the oscillation frequency,  $R_s$  is the resonator series resistance and  $C_p$  its parallel capacitance.

This means :  $R_{\text{bias}} \gg 8 \text{k}\Omega$  ; the value of  $100 \text{k}\Omega$  is sufficiently large.

## 8.13 EMC SAA7709H application

In order to optimise the EMC behaviour of the SAA7709H device, some measures are taken in the SAA7709H design :

1. On-chip decoupling capacitor ; this reduces the high frequency components of the supply currents.
2. Distributed clock ; the switching moments of the digital circuitry is spread in time.
3. Adjustable PLL frequency for the DSP ; this enables to change core frequency under microprocessor control in case FM reception is interfered by the SAA7709H emission.
4. Edge controlled digital outputs (controlled rise- and fall times) ; this reduces the high frequency components that could interfere with radio reception.

To further optimise the EMC behaviour of the SAA7709H in a CDSP application, some additional measures are required, see also the SAA7709H application diagram.

1. Supply filtering digital circuitry DSP core  
The EMC most critical supply pins are VDDD1 and VDDD2.  
Via these pins the core is supplied, so the bulk of the digital current is flowing through these pins. To suppress interferences a choke BLM21A10 should be added in the supply line.
2. Supply filtering Analog to Digital Convertors  
The Analog to Digital Convertors are supplied via the VDDAAD pin. In order to decrease the groundbounce in the chip and to increase the analog performance will increase) a choke BLM21A10 must be added in the supply line (VDDAAD). It's important that no decoupling capacitor is connected to the VDDAAD pin, see appendix 1.
3. Supply filtering peripheral supply  
The peripheral I/O circuitry is supplied via VDDQ1, VDDQ2 and VDDQ3.  
In order to suppress interferences a 10 Ohm series resistor and a decoupling capacitor of 22 nF are added to these pins (see appendix 1).
4. Main ground plane  
The pinning of the CDSP chip has been chosen in such a way that the lay-out is possible with a double sided PCB. It is recommended to create a ground plane on the non-SMD side of the PCB. This main ground plane provides a low inductance ground return for the power supply and signal currents. This plane act as an equipotential point for the digital as well as for the analogue parts of the CDSP circuitry. The EMC critical peripheral components should be above the plane.
5. Ground plane under the CDSP chip  
It is recommended to provide a ground plane under the CDSP chip at the SMD side of the PCB. The six ground pins (VSSSx) of the digital related signals and the oscillator ground pin (VSS\_OSC) have to be connected directly to this plane in order to reduce the loop area of the digital supply, this reduces the EMC emission and ground bounce. This small ground plane has to be connected to the main ground plane with sufficient vias. Do not use the small ground plane under the chip for the other ground pins, these have to be directly connected to the main ground plane.
6. Oscillator circuit  
Mount the oscillator peripheral components (XTAL, Cx1 and Cx2, see figure 8.25) as close as possible to the CDSP chip. The oscillator supply is separately filtered with components a capacitor of 100nF and a choke (BLM21A10), see appendix 1.



7. filtering DAC outputs

- On all four analogue outputs the same filtering are used. This is described in figure 8.1. first order RC-filtering of the analogue output signals will be done with a 100 Ohm resistor and a 10nF capacitor. Furthermore it is important to separate the supply of the digital circuitry from the supply of the analogue circuitry. In case an analogue +5V supply is used for generating the +3.3V for VDDA2 (supply of FSDAC) it is recommended to add a 100 µH coil in series with the +5V analogue supply line.

## 8.14 Changing the clock frequency of the DSP

By default the DSP in the SAA7709H are running on a frequency of:

DSP clock frequency = 69.854 MHz

The EMI behaviour of the SAA7709H is very good and in normal cases there is no interference with FM reception, however if desired it is possible to slightly increase the clock frequency of the DSP by changing the divide factor of the PLL that generates the DSP clock signal.

A decrease of the DSP clock frequency is possible but **NOT** allowed because this decreases the number of DSP program cycles below the number of required program cycles.

An increase of one of the DSP clock frequencies is of course only applicable if the second harmonic of the DSP clock interferes with the frequency of the selected FM station.

### 8.14.1 Procedure for increasing the clock frequency of the DSP

The DSP clock signal is generated by PLL1, the default divide factor of PLL1 is 198, this result in a clock frequency of 69.854 MHz. The divide factor is set via bits 1 .. 5 of the IIC\_DSP\_CNTR register (address \$602F).

# Appendix 1 : Application diagram

