



# Heterojunction Bipolar Transistor Technology (InGaP HBT)

## High Efficiency/Linearity Amplifier

The MMA25312B is a high efficiency InGaP HBT amplifier designed for use in 2400 MHz ISM applications, WLAN (802.11g), WiMAX (802.16e) and wireless broadband mesh networks. It is suitable for applications with frequencies from 2300 to 2700 MHz using simple external matching components with a 3 to 5 volt supply.

### Features

- Frequency: 2300–2700 MHz
- P1dB: 31 dBm @ 2500 MHz
- Power Gain: 26 dB @ 2500 MHz
- OIP3: 40 dBm @ 2500 MHz
- Active Bias Control (On-chip)
- Single 3 to 5 Volt Supply
- Single-ended Power Detector
- Cost-effective QFN Surface Mount Package
- In Tape and Reel. T1 Suffix = 1,000 Units, 12 mm Tape Width, 7 inch Reel.

**MMA25312BT1**

**2300–2700 MHz, 26 dB  
 31 dBm  
 InGaP HBT**



**CASE 2131-01  
 QFN 3x3  
 PLASTIC**

**Table 1. Typical CW Performance (1)**

Characteristic	Symbol	2300 MHz	2500 MHz	2700 MHz	Unit
Small-Signal Gain (S21)	$G_p$	26	26	24.5	dB
Input Return Loss (S11)	IRL	-14	-12	-12	dB
Output Return Loss (S22)	ORL	-11	-13	-15	dB
Power Output @ 1dB Compression	P1dB	30	31	29.8	dBm

1.  $V_{CC1} = V_{CC2} = V_{BIAS} = 5$  Vdc,  $T_A = 25^\circ\text{C}$ , 50 ohm system, CW Application Circuit

**Table 2. Maximum Ratings**

Rating	Symbol	Value	Unit
Supply Voltage	$V_{CC}$	6	V
Supply Current	$I_{CC}$	550	mA
RF Input Power	$P_{in}$	30	dBm
Storage Temperature Range	$T_{stg}$	-65 to +150	$^\circ\text{C}$
Junction Temperature (2)	$T_J$	150	$^\circ\text{C}$

2. For reliable operation, the junction temperature should not exceed  $150^\circ\text{C}$ .

**Table 3. Thermal Characteristics**

Characteristic	Symbol	Value (3)	Unit
Thermal Resistance, Junction to Case Case Temperature $91^\circ\text{C}$ , $V_{CC1} = V_{CC2} = V_{BIAS} = 5$ Vdc	$R_{\theta JC}$	92	$^\circ\text{C/W}$

3. Refer to AN1955, *Thermal Measurement Methodology of RF Power Amplifiers*. Go to <http://www.freescale.com/rf>. Select Documentation/Application Notes - AN1955.

**Table 4. Electrical Characteristics** ( $V_{CC1} = V_{CC2} = V_{BIAS} = 5$  Vdc, 2500 MHz,  $T_A = 25^\circ\text{C}$ , 50 ohm system, in Freescale CW Application Circuit)

Characteristic	Symbol	Min	Typ	Max	Unit
Small-Signal Gain (S21)	$G_p$	24.5	26	—	dB
Input Return Loss (S11)	IRL	—	-12	—	dB
Output Return Loss (S22)	ORL	—	-13	—	dB
Power Output @ 1dB Compression	P1dB	—	31	—	dBm
Third Order Output Intercept Point, Two-Tone CW	OIP3	—	40	—	dBm
Noise Figure	NF	—	3.8	—	dB
Supply Current <sup>(1)</sup>	$I_{CQ}$	110	124	138	mA
Supply Voltage <sup>(1)</sup>	$V_{CC}$	—	5	—	V

**Table 5. ESD Protection Characteristics**

Test Methodology	Class
Human Body Model (per JESD 22-A114)	2
Machine Model (per EIA/JESD 22-A115)	A
Charge Device Model (per JESD 22-C101)	IV

**Table 6. Moisture Sensitivity Level**

Test Methodology	Rating	Package Peak Temperature	Unit
Per JESD22-A113, IPC/JEDEC J-STD-020	1	260	$^\circ\text{C}$

1. For reliable operation, the junction temperature should not exceed  $150^\circ\text{C}$ .

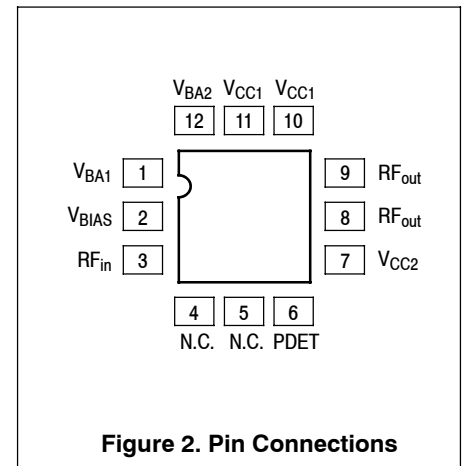
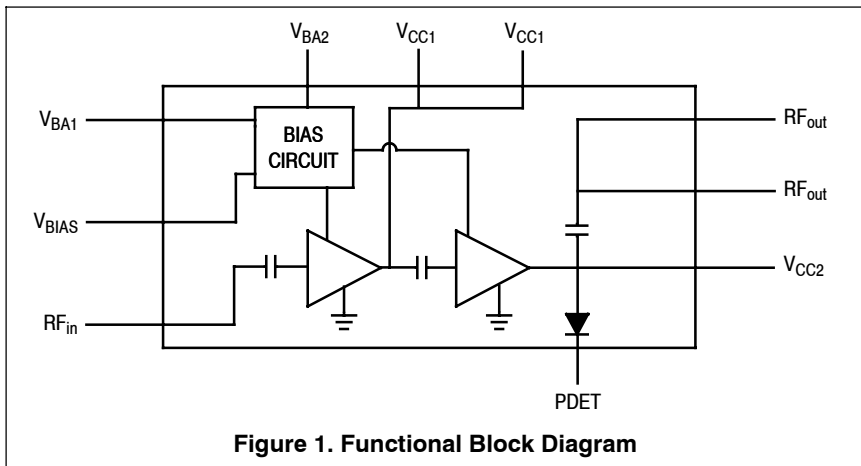

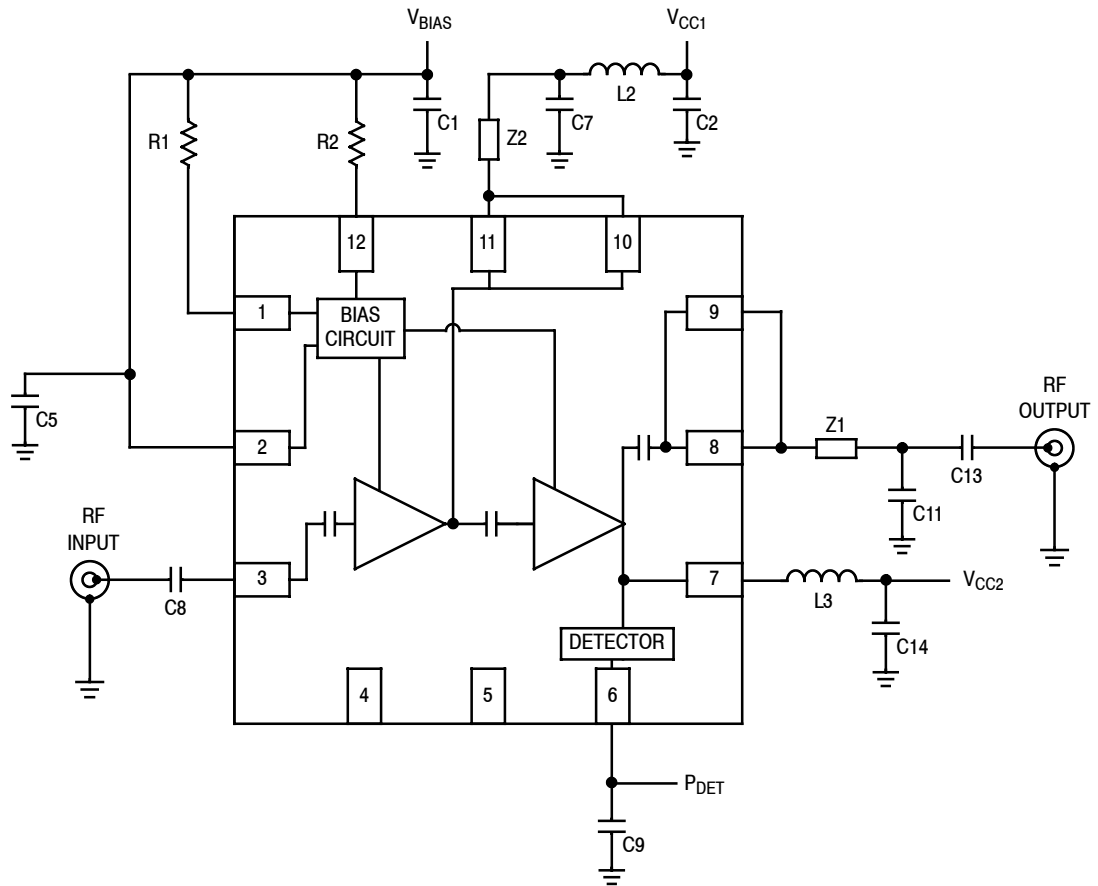

Z1 0.140" x 0.030" Microstrip  
 Z2 0.073" x 0.030" Microstrip

Figure 3. MMA25312BT1 Test Circuit Schematic — 2500 MHz, 5 Volt Operation

Table 7. MMA25312BT1 Test Circuit Component Designations and Values — 2500 MHz, 5 Volt Operation

Part	Description	Part Number	Manufacturer
C1, C2	1 $\mu$ F Chip Capacitors	GRM155R61A105KE15	Murata
C3, C4, C6, C10, C12, C15	Components Not Placed		
C5, C9	100 pF Chip Capacitors	GRM1555C1H101JA01	Murata
C7	8.2 pF Chip Capacitor	04023J8R2BBS	AVX
C8, C13	22 pF Chip Capacitors	04023J22R0BBS	AVX
C11	1.5 pF Chip Capacitor	04023J1R5BBS	AVX
C14	4.7 $\mu$ F Chip Capacitor	GRM188R60J475KE19D	Murata
L2	1.2 nH Chip Inductor	LL1608-FH1N2S	TOKO
L3	22 nH Chip Inductor	LL1608-FH22N0S	TOKO
R1	430 $\Omega$ , 1/16 W Chip Resistor	RC0402JR-07430RL	Yageo
R2	1.6 k $\Omega$ , 1/16 W Chip Resistor	RC0402JR-071K60L	Yageo
R3	Component Not Placed		
PCB	0.014", $\epsilon_r = 3.7$	FR408	Isola

Note: Component numbers C3, C4, C6, C10, C12, C15 and R3 are labeled on board but not placed.

Note: Component L1 intentionally omitted.

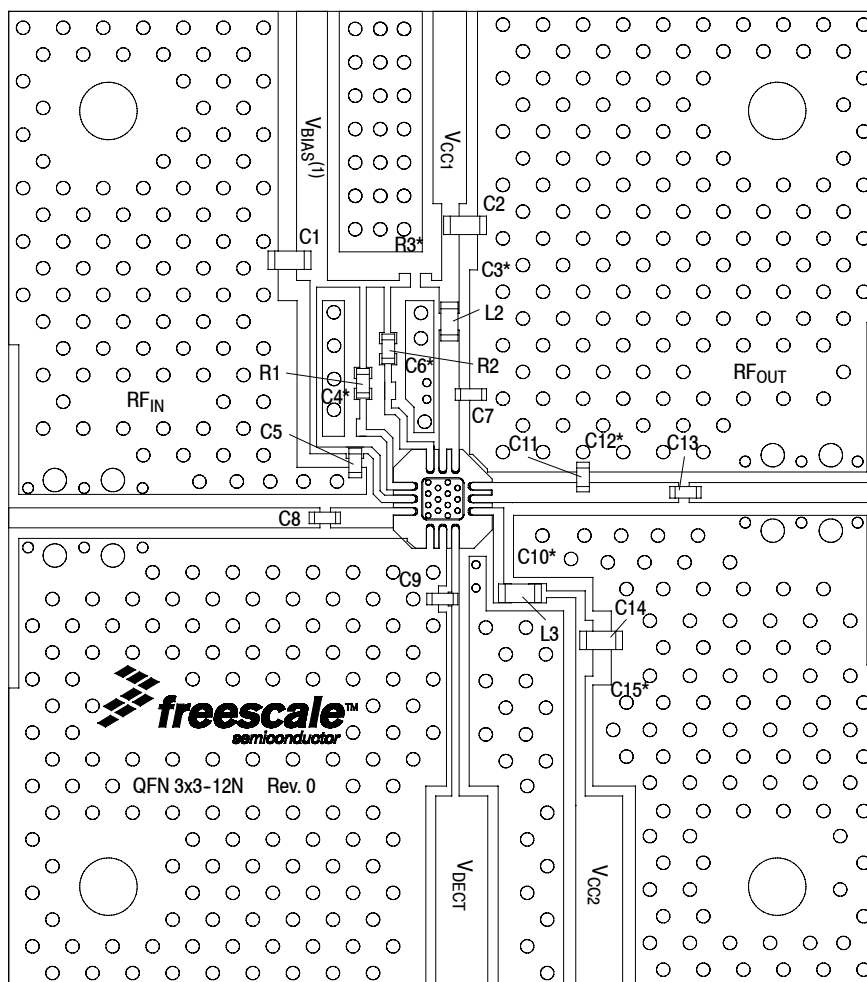

(1) V<sub>BIAS</sub> [Board] supplies V<sub>BA1</sub>, V<sub>BA2</sub> and V<sub>BIAS</sub> [Device].

Note: Component numbers C3\*, C4\*, C6\*, C10\*, C12\*, C15\* and R3\* are labeled on board but not placed.

**Figure 4. MMA25312BT1 Test Circuit Component Layout — 2500 MHz, 5 Volt Operation**

**Table 7. MMA25312BT1 Test Circuit Component Designations and Values — 2500 MHz, 5 Volt Operation**

Part	Description	Part Number	Manufacturer
C1, C2	1 $\mu$ F Chip Capacitors	GRM155R61A105KE15	Murata
C3, C4, C6, C10, C12, C15	Components Not Placed		
C5, C9	100 pF Chip Capacitors	GRM1555C1H101JA01	Murata
C7	8.2 pF Chip Capacitor	04023J8R2BBS	AVX
C8, C13	22 pF Chip Capacitors	04023J22R0BBS	AVX
C11	1.5 pF Chip Capacitor	04023J1R5BBS	AVX
C14	4.7 $\mu$ F Chip Capacitor	GRM188R60J475KE19D	Murata
L2	1.2 nH Chip Inductor	LL1608-FH1N2S	TOKO
L3	22 nH Chip Inductor	LL1608-FH22N0S	TOKO
R1	430 $\Omega$ , 1/16 W Chip Resistor	RC0402JR-07430RL	Yageo
R2	1.6 k $\Omega$ , 1/16 W Chip Resistor	RC0402JR-071K60L	Yageo
R3	Component Not Placed		
PCB	0.014", $\epsilon_r = 3.7$	FR408	Isola

Note: Component L1 intentionally omitted.

(Component Designations and Values table repeated for reference.)

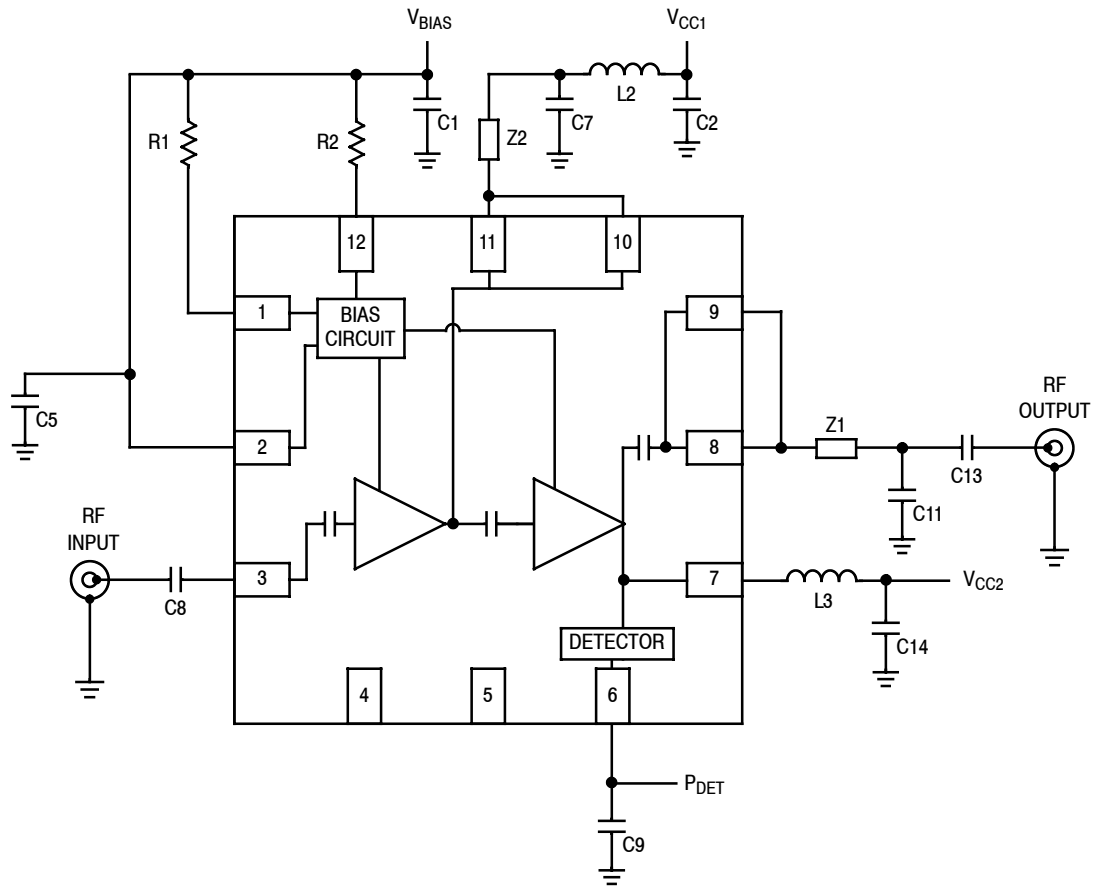

Z1 0.140" x 0.030" Microstrip  
 Z2 0.073" x 0.030" Microstrip

Figure 5. MMA25312BT1 Test Circuit Schematic — 2500 MHz, 3.3 Volt Operation

Table 8. MMA25312BT1 Test Circuit Component Designations and Values — 2500 MHz, 3.3 Volt Operation

Part	Description	Part Number	Manufacturer
C1, C2	1 $\mu$ F Chip Capacitors	GRM155R61A105KE15	Murata
C3, C4, C6, C10, C12, C15	Components Not Placed		
C5, C9	100 pF Chip Capacitors	GRM1555C1H101JA01	Murata
C7	8.2 pF Chip Capacitor	04023J8R2BBS	AVX
C8, C13	22 pF Chip Capacitors	04023J22R0BBS	AVX
C11	1.5 pF Chip Capacitor	04023J1R5BBS	AVX
C14	4.7 $\mu$ F Chip Capacitor	GRM188R60J475KE19D	Murata
L2	1.2 nH Chip Inductor	LL1608-FH1N2S	TOKO
L3	22 nH Chip Inductor	LL1608-FH22N0S	TOKO
R1	100 $\Omega$ , 1/16 W Chip Resistor	RC0402JR-07100RL	Yageo
R2	470 $\Omega$ , 1/16 W Chip Resistor	RC0402JR-07470RL	Yageo
R3	Component Not Placed		
PCB	0.014", $\epsilon_r = 3.7$	FR408	Isola

Note: Component numbers C3, C4, C6, C10, C12, C15 and R3 are labeled on board but not placed.

Note: Component L1 intentionally omitted.

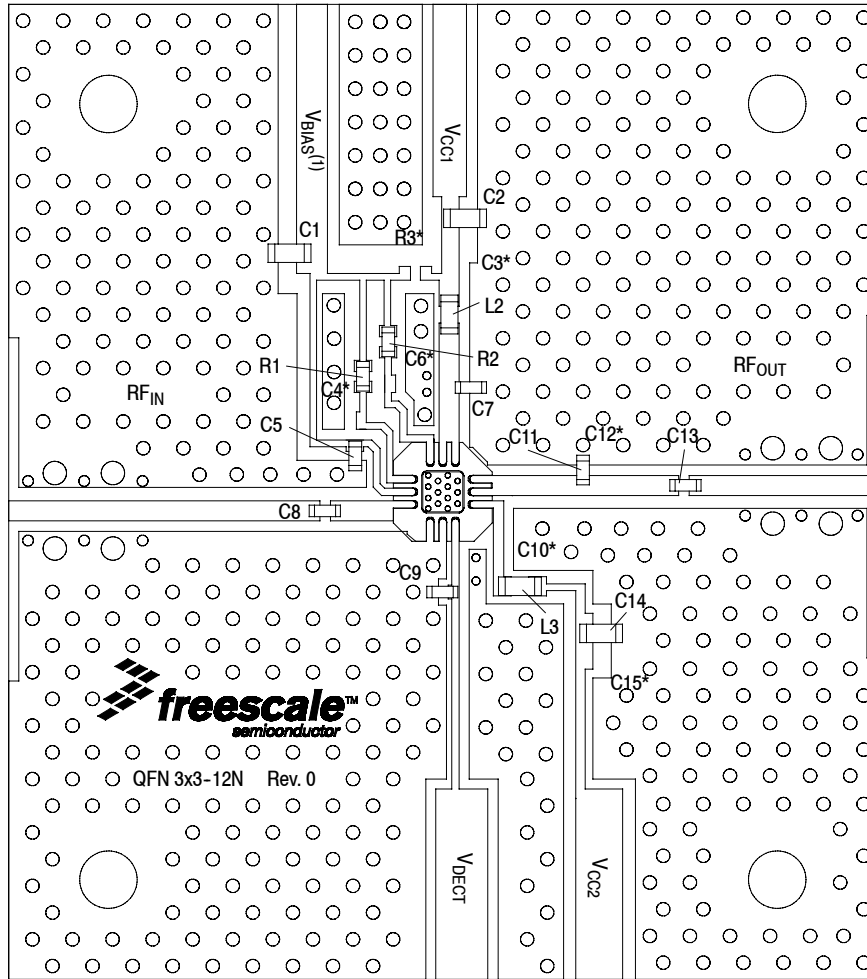

(1) V<sub>BIAS</sub> [Board] supplies V<sub>BA1</sub>, V<sub>BA2</sub> and V<sub>BIAS</sub> [Device].

Note: Component numbers C3\*, C4\*, C6\*, C10\*, C12\*, C15\* and R3\* are labeled on board but not placed.

**Figure 6. MMA25312BT1 Test Circuit Component Layout — 2500 MHz, 3.3 Volt Operation**

**Table 8. MMA25312BT1 Test Circuit Component Designations and Values — 2500 MHz, 3.3 Volt Operation**

Part	Description	Part Number	Manufacturer
C1, C2	1 $\mu$ F Chip Capacitors	GRM155R61A105KE15	Murata
C3, C4, C6, C10, C12, C15	Components Not Placed		
C5, C9	100 pF Chip Capacitors	GRM1555C1H101JA01	Murata
C7	8.2 pF Chip Capacitor	04023J8R2BBS	AVX
C8, C13	22 pF Chip Capacitors	04023J22R0BBS	AVX
C11	1.5 pF Chip Capacitor	04023J1R5BBS	AVX
C14	4.7 $\mu$ F Chip Capacitor	GRM188R60J475KE19D	Murata
L2	1.2 nH Chip Inductor	LL1608-FH1N2S	TOKO
L3	22 nH Chip Inductor	LL1608-FH22N0S	TOKO
R1	100 $\Omega$ , 1/16 W Chip Resistor	RC0402JR-07100RL	Yageo
R2	470 $\Omega$ , 1/16 W Chip Resistor	RC0402JR-07470RL	Yageo
R3	Component Not Placed		
PCB	0.014", $\epsilon_r = 3.7$	FR408	Isola

Note: Component L1 intentionally omitted.

(Component Designations and Values table repeated for reference.)

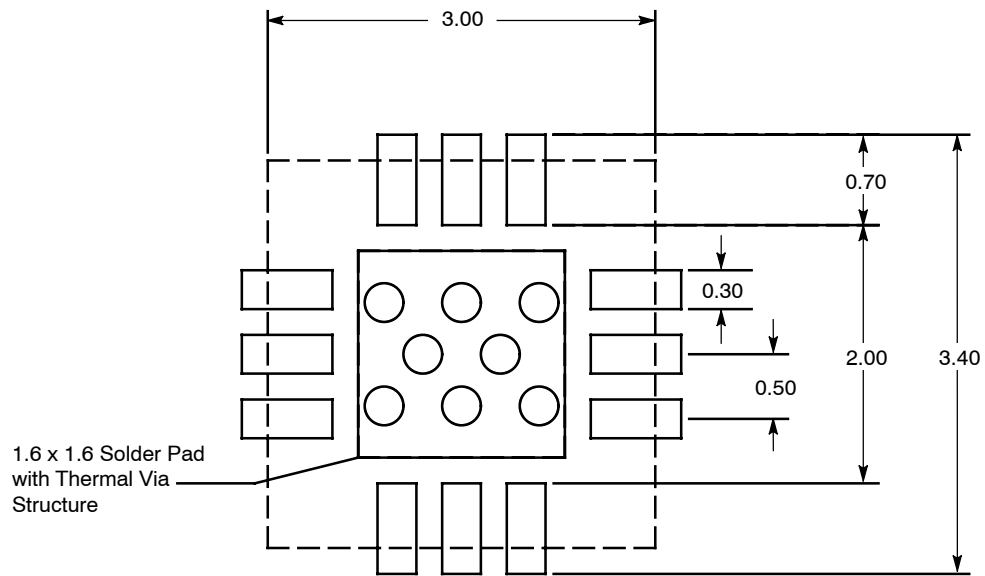
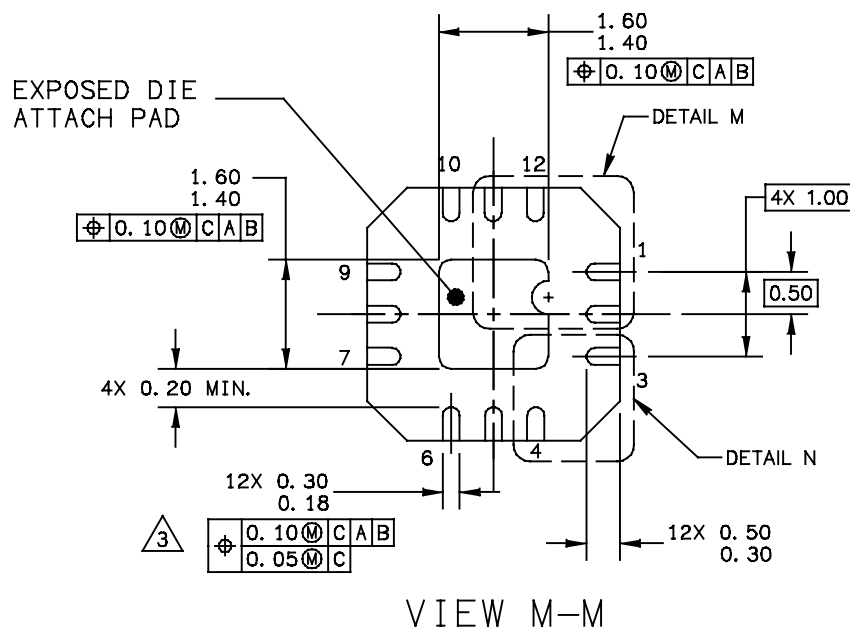
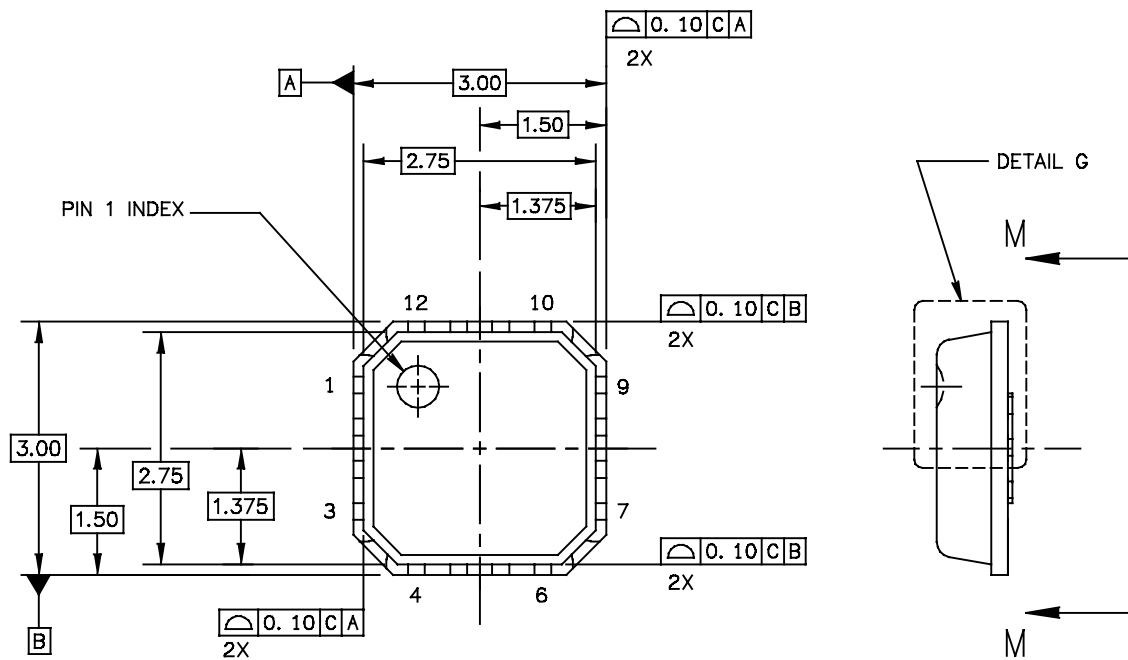

Figure 7. PCB Pad Layout for QFN 3x3



Figure 8. Product Marking

## PACKAGE DIMENSIONS



© FREESCALE SEMICONDUCTOR, INC. ALL RIGHTS RESERVED.	MECHANICAL OUTLINE	PRINT VERSION NOT TO SCALE	
TITLE: THERMALLY ENHANCED QUAD FLAT NON-LEADED PACKAGE (QFN) 12 TERMINAL, 0.5 PITCH (3X3X0.85)	DOCUMENT NO: 98ASA00227D	REV: 0	
	CASE NUMBER: 2131-01	14 MAY 2010	
	STANDARD: NON-JEDEC		



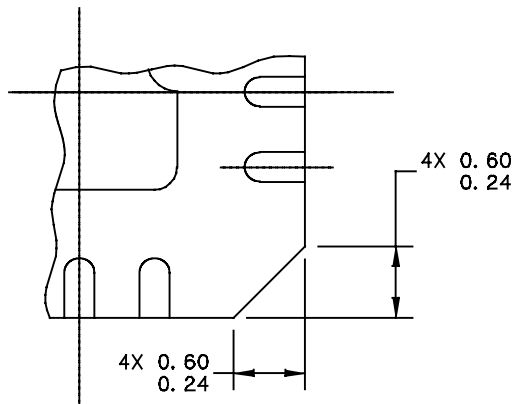

DETAIL N  
CORNER CONFIGURATION

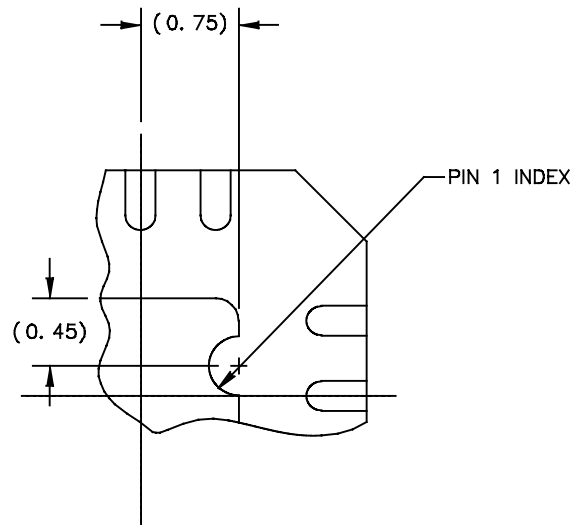

DETAIL M  
PIN 1 BACKSIDE INDEX

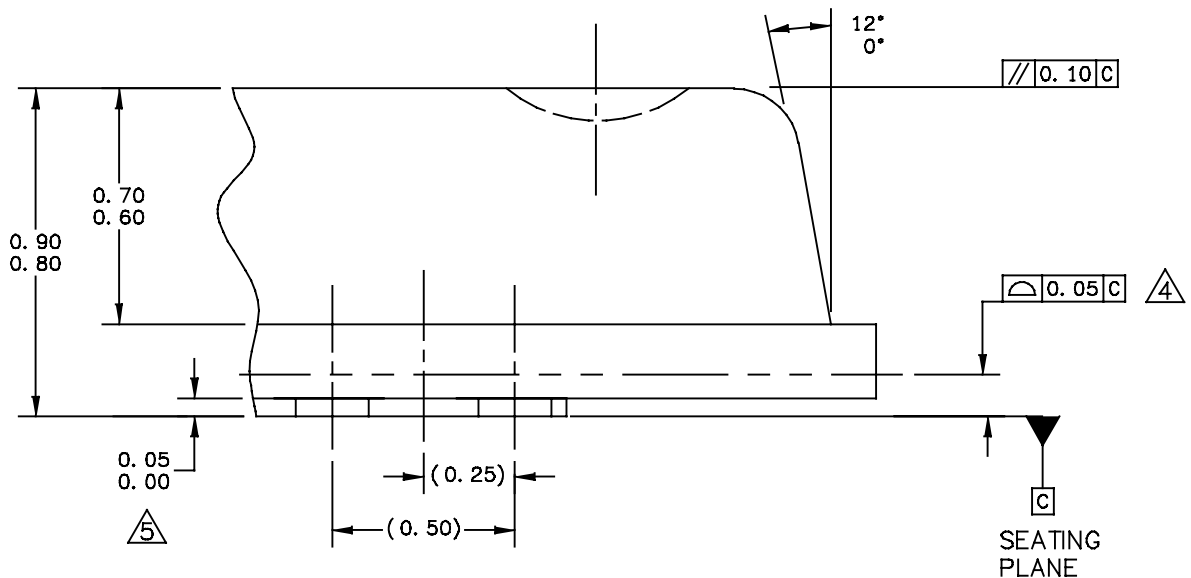

DETAIL G  
VIEW ROTATED 90° CW

© FREESCALE SEMICONDUCTOR, INC. ALL RIGHTS RESERVED.	MECHANICAL OUTLINE	PRINT VERSION NOT TO SCALE	
TITLE: THERMALLY ENHANCED QUAD FLAT NON-LEADED PACKAGE (QFN) 12 TERMINAL, 0.5 PITCH (3X3X0.85)	DOCUMENT NO: 98ASA00227D	REV: 0	
	CASE NUMBER: 2131-01	14 MAY 2010	
	STANDARD: NON-JEDEC		

NOTE:

1. ALL DIMENSIONS ARE IN MILLIMETERS.

2. DIMENSIONING & TOLERANCING PER ASME Y14.5 – 2009.

3. THIS DIMENSION APPLIES TO PLATED TERMINAL AND IS MEASURED BETWEEN 0.15 AND 0.30 MM FROM TERMINAL TIP.

4. BILATERAL COPLANARITY ZONE APPLIES TO THE EXPOSED PAD AS WELL AS THE TERMINALS.

5. THIS DIMENSION APPLIED ONLY FOR TERMINALS.

© FREESCALE SEMICONDUCTOR, INC. ALL RIGHTS RESERVED.	MECHANICAL OUTLINE	PRINT VERSION NOT TO SCALE	
TITLE: THERMALLY ENHANCED QUAD FLAT NON-LEADED PACKAGE (QFN) 12 TERMINAL, 0.5 PITCH (3X3X0.85)	DOCUMENT NO: 98ASA00227D	REV: 0	
	CASE NUMBER: 2131-01	14 MAY 2010	
	STANDARD: NON-JEDEC		

## PRODUCT DOCUMENTATION, SOFTWARE AND TOOLS

Refer to the following documents, software and tools to aid your design process.

### Application Notes

- AN1955: Thermal Measurement Methodology of RF Power Amplifiers
- AN3100: General Purpose Amplifier and MMIC Biasing

### Software

- .s2p File

### Development Tools

- Printed Circuit Boards

For Software and Tools, do a Part Number search at <http://www.freescale.com>, and select the “Part Number” link. Go to the Software & Tools tab on the part’s Product Summary page to download the respective tool.

## REVISION HISTORY

The following table summarizes revisions to this document.

Revision	Date	Description
0	Sept. 2012	• Initial Release of Data Sheet

## **How to Reach Us:**

**Home Page:**  
[freescale.com](http://freescale.com)

**Web Support:**  
[freescale.com/support](http://freescale.com/support)

Information in this document is provided solely to enable system and software implementers to use Freescale products. There are no express or implied copyright licenses granted hereunder to design or fabricate any integrated circuits based on the information in this document.

Freescale reserves the right to make changes without further notice to any products herein. Freescale makes no warranty, representation, or guarantee regarding the suitability of its products for any particular purpose, nor does Freescale assume any liability arising out of the application or use of any product or circuit, and specifically disclaims any and all liability, including without limitation consequential or incidental damages. "Typical" parameters that may be provided in Freescale data sheets and/or specifications can and do vary in different applications, and actual performance may vary over time. All operating parameters, including "typicals," must be validated for each customer application by customer's technical experts. Freescale does not convey any license under its patent rights nor the rights of others. Freescale sells products pursuant to standard terms and conditions of sale, which can be found at the following address: [freescale.com/SalesTermsandConditions](http://freescale.com/SalesTermsandConditions).

Freescale, the Freescale logo, Altivec, C-5, CodeTest, CodeWarrior, ColdFire, C-Ware, Energy Efficient Solutions logo, Kinetis, mobileGT, PowerQUICC, Processor Expert, QorIQ, Qorivva, StarCore, Symphony, and VortiQa are trademarks of Freescale Semiconductor, Inc., Reg. U.S. Pat. & Tm. Off. Airfast, BeeKit, BeeStack, ColdFire+, CoreNet, Flexis, MagniV, MXC, Platform in a Package, QorIQ Qonverge, QUICC Engine, Ready Play, SafeAssure, SMARTMOS, TurboLink, Vybrid, and Xtrinsic are trademarks of Freescale Semiconductor, Inc. All other product or service names are the property of their respective owners.

© 2012 Freescale Semiconductor, Inc.

