

Amplifier, Power, 1W
 5.0-9.0 GHz

MAAPGM0030
 903239 —
 Preliminary Information

Features

- ◆ 1 Watt Saturated Output Power Level
- ◆ Variable Drain Voltage (4-10V) Operation
- ◆ MSAG™ Process

Primary Applications

- ◆ Multiple Band Point-to-Point Radio
- ◆ SatCom
- ◆ ISM Band

Description

The MAAPGM0030 is a packaged, single stage, 1W power amplifier with on-chip bias networks in a bolt down ceramic package, allowing easy assembly. This product is fully matched to 50 ohms on both the input and output. It can be used as a power amplifier stage or as a driver stage in high power applications.

Each device is 100% RF tested to ensure performance compliance. The part is fabricated using M/A-COM's GaAs Multifunction Self-Aligned Gate (MSAG™) Process.

M/A-COM's MSAG™ process features robust silicon-like manufacturing processes, planar processing of ion implanted transistors and multiple implant capability enabling power, low-noise, switch and digital FETs on a single chip. The use of refractory metals and the absence of platinum in the gate metal formulation prevents hydrogen poisoning when employed in hermetic packaging.

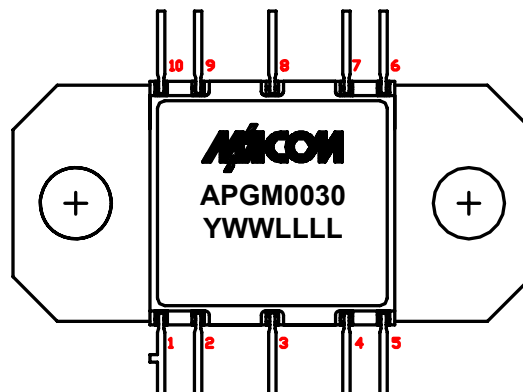

Pin Number	RF Designator
1	No Connection
2	No Connection
3	RF IN
4	No Connection
5	V _{GG}
6	No Connection
7	No Connection
8	RF OUT
9	No Connection
10	V _{DD}

Absolute Maximum Conditions ¹

Parameter	Symbol	Absolute Maximum	Units
Input Power	P _{IN}	23.0	dBm
Drain Supply Voltage	V _{DD}	+12.0	V
Gate Supply Voltage	V _{GG}	-3.0	V
Quiescent Drain Current (No RF, 40% Idss)	I _{DQ}	470	mA
Quiescent DC Power Dissipated (No RF)	P _{DISS}	3.2	W
Junction Temperature	T _J	180	°C
Storage Temperature	T _{STG}	-55 to +150	°C
Processing Temperature		230	°C

1. Operation outside of these ranges may reduce product reliability.

1

M/A-COM Inc. and its affiliates reserve the right to make changes to the product(s) or information contained herein without notice. M/A-COM makes no warranty, representation or guarantee regarding the suitability of its products for any particular purpose, nor does M/A-COM assume any liability whatsoever arising out of the use or application of any product(s) or information.

• **North America** Tel: 800.366.2266 / Fax: 978.366.2266
 • **Europe** Tel: 44.1908.574.200 / Fax: 44.1908.574.300
 • **Asia/Pacific** Tel: 81.44.844.8296 / Fax: 81.44.844.8298

Visit www.macom.com for additional data sheets and product information.

Amplifier, Power, 1W
5.0-9.0 GHz

MAAPGM0030
903239 —
Preliminary Information

Recommended Operating Conditions

Characteristic	Symbol	Min	Typ	Max	Unit
Drain Supply Voltage	V_{DD}	4.0	8.0	10.0	V
Gate Supply Voltage	V_{GG}	-2.4	-2.0	-1.5	V
Input Power	P_{IN}		18	21	dBm
Junction Temperature	T_J			150	°C
Thermal Resistance	Θ_{JC}		28.4		°C/W
Package Base Temperature	T_B			Note 2	°C

2. Maximum Package Base Temperature = $150^{\circ}\text{C} - \Theta_{JC} * V_{DD} * I_{DQ}$

Electrical Characteristics: $T_B = 40^{\circ}\text{C}$, $Z_0 = 50 \Omega$, $V_{DD} = 8\text{V}$, $I_{DQ} \approx 300 \text{ mA}^3$, $P_{in} = 18 \text{ dBm}$, $R_G \approx 240 \Omega$

Parameter	Symbol	Typical	Units
Bandwidth	f	5.0-9.0	GHz
Output Power	POUT	30	dBm
Power Added Efficiency	PAE	35	%
1-dB Compression Point	P1dB	30	dBm
Small Signal Gain	G	14	dB
Input VSWR	VSWR	1.8:1	
Output VSWR	VSWR	2.0:1	
Gate Supply Current	I_{GG}	< 4	mA
Drain Supply Current	I_{DD}	< 500	mA
Noise Figure	NF	9	dB
2 nd Harmonic	2f	-20	dBc
3 rd Harmonic	3f	-35	dBc
Output Third Order Intercept	OTOI	38	dBm
3 rd Order Intermodulation Distortion, Single Carrier Level = 21 dBm	IM3	-15	dBm
5 th Order Intermodulation Distortion, Single Carrier Level = 21 dBm	IM5	-36	dBm

3. Adjust V_{GG} between -2.4 to -1.5V to achieve indicated I_{DQ} .

Operating Instructions

This device is static sensitive. Please handle with care. To operate the device, follow these steps.

1. Apply $V_{GG} \approx -1.8\text{V}$, $V_{DD} = 0 \text{ V}$.
2. Ramp V_{DD} to desired voltage, typically 8 V.
3. Adjust V_{GG} to set I_{DQ} , (See Note 3 above).
4. Set RF input.
5. Power down sequence in reverse. Turn V_{GG} off last.

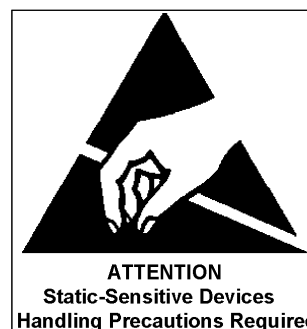

**Amplifier, Power, 1W
5.0-9.0 GHz**

MAAPGM0030
903239 —
Preliminary Information

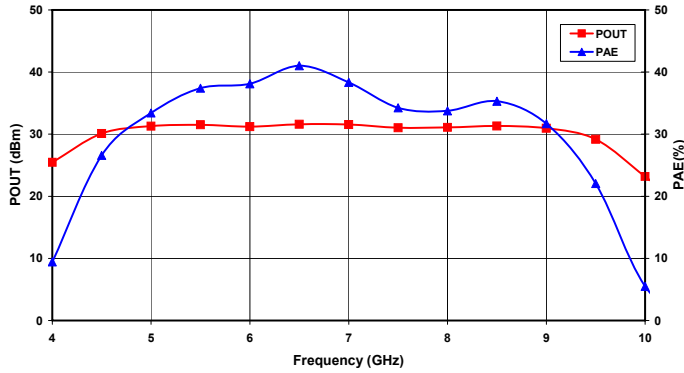

Figure 1. Output Power and Power Added Efficiency vs. Frequency at $V_{DD} = 8V$ and $P_{in} = 18\text{ dBm}$.

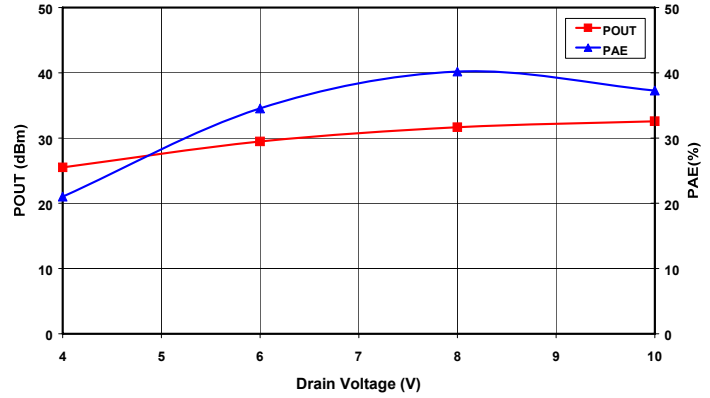

Figure 2. Saturated Output Power and Power Added Efficiency vs. Drain Voltage at $f_0 = 7\text{ GHz}$.

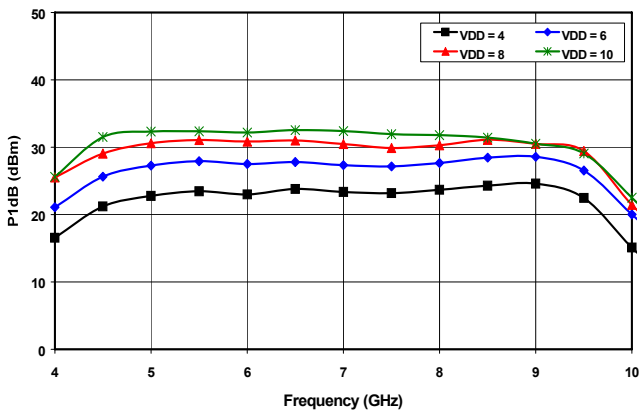

Figure 3. 1dB Compression Point vs. Drain Voltage

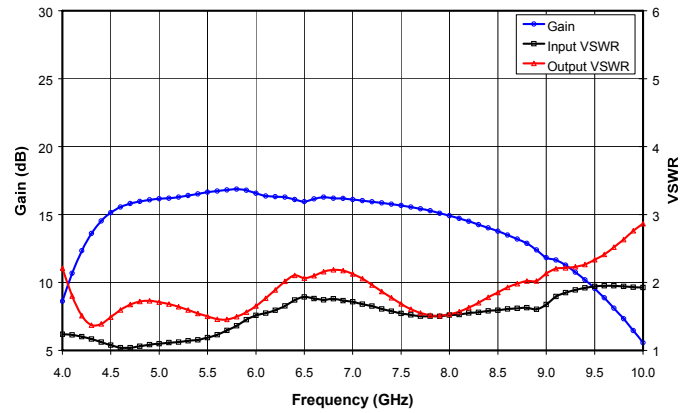

Figure 4. Small Signal Gain and VSWR vs. Frequency at $V_{DD} = 8V$.

**Amplifier, Power, 1W
5.0-9.0 GHz**

MAAPGM0030
903239 —
Preliminary Information

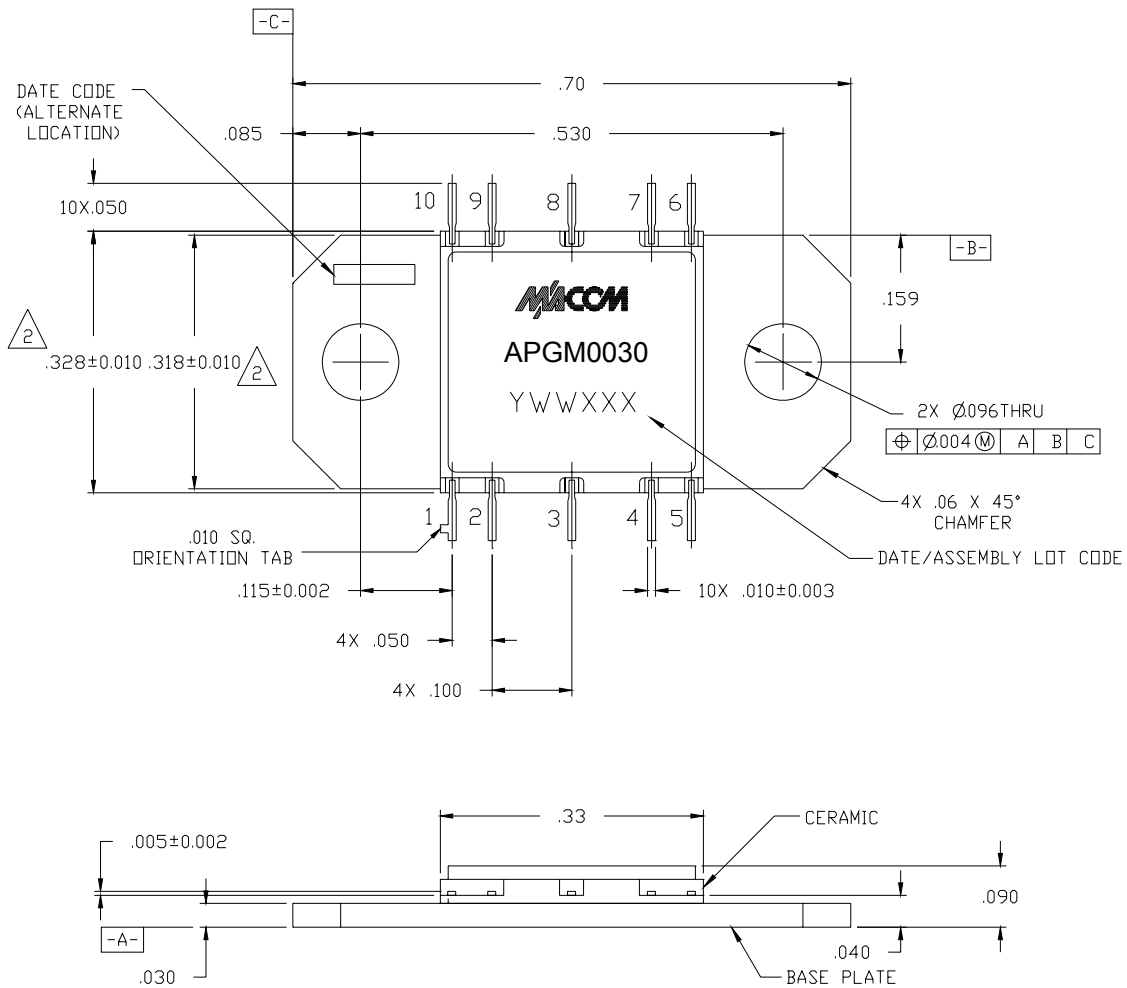

Figure 5. CR-15 Package Dimensions

The CR-15 is a high frequency, low thermal resistance package. The package consists of a cofired ceramic construction with a copper-tungsten base and iron-nickel-cobalt leads. The finish consists of electrolytic gold over nickel plate.

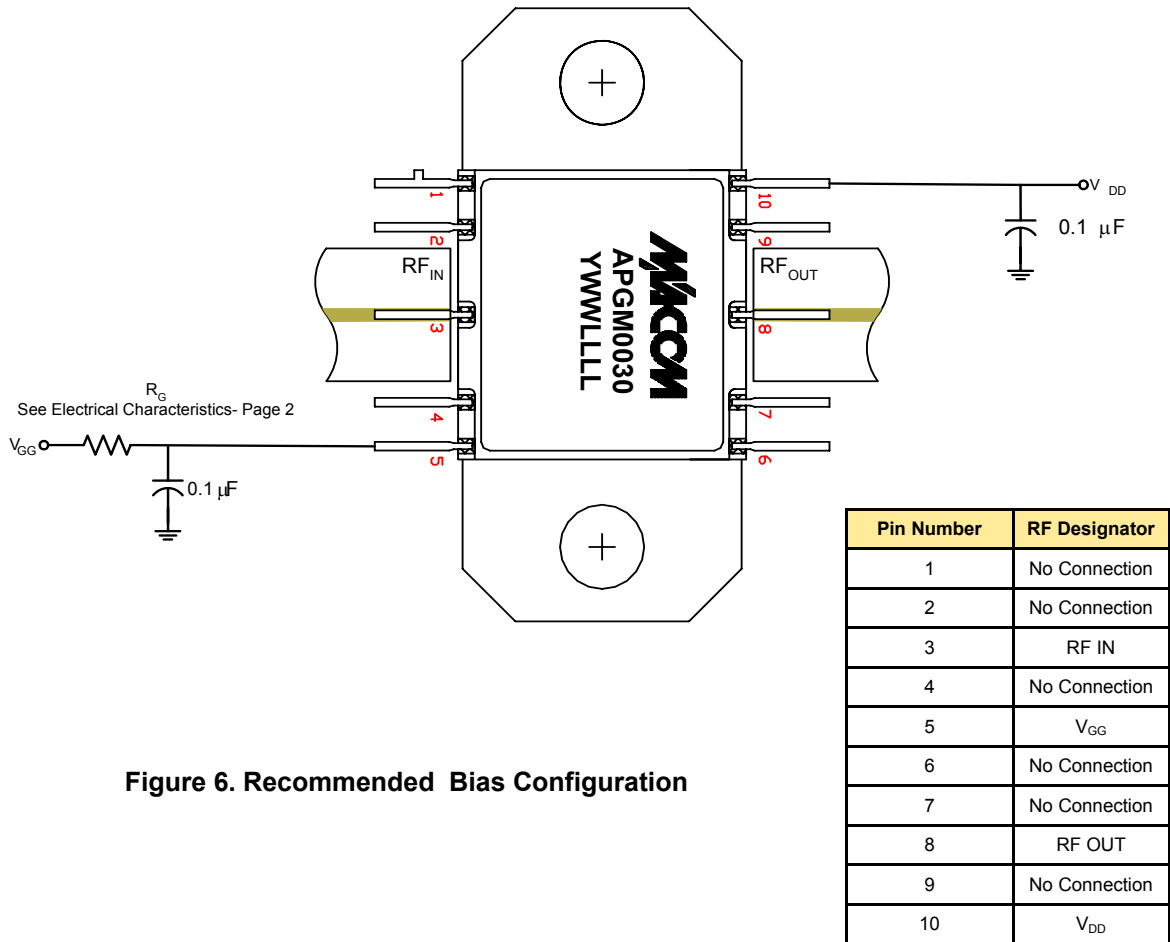

Figure 6. Recommended Bias Configuration

Assembly Instructions:

This flange mount style package provides a robust interface between a highly integrated GaAs MMIC device and a circuit board which may be assembled using conventional surface mount techniques. A thin shim made of a thermally and electrically conductive, ductile material should be used prior to installation of the CR-15 to improve the thermal and electrical performance of the package to housing interface. Refer to **M/A-COM Application Note #M567*** for more information.

For applications where surface mount components are to be installed after the CR-15 installation, this package will not be damaged when subjected to typical convection or IR oven reflow profiles. Refer to **M/A-COM Application Note #M538*** for maximum allowable reflow time and temperature. Alternatively, the package leads may be individually soldered. Whether an iron or hot gas soldering equipment is used, care should be taken to insure that the temperature is well controlled and electric static discharge (ESD) safe.

* Application Notes can be found by going to the Site Search Page on M/A-COM's web page (<http://www.macom.com/search/search.jsp>) and searching for the required Application Note.

Biassing Notes:

- ◆ A negative bias must be applied to V_{GG} before applying a positive bias to V_{DD} to prevent damage to the amplifier.