A red square graphic is located in the top left corner of the slide, enclosed within a thin red square border. It is positioned at the intersection of a vertical red line and a horizontal red line that spans the width of the slide.

# Difference among various products of 7560 Group

Renesas Technology Corporation  
Renesas LSI Design Corporation  
Renesas Solutions Corporation



## Products effected

- Emulator MCU Standard version  
M37560RLFS
- One-time PROM version Standard version  
M37560EFFP/GP
- Mask ROM version Standard version  
M37560M8-XXXFP/GP, M37560MF-XXXFP/GP
- Mask ROM version A version  
M37560M8A-XXXFP/GP, M37560MFA-XXXFP/GP

## Precaution

- When Mask ROM version, One-time PROM version and memory size differ in one group, actual values such as an electrical characteristics, operation margin, A-D conversion accuracy, noise immunity, and noise radiation may differ from the ideal values due to the difference in the manufacturing processes. When these products are used switching, perform system evaluation for each product of every after confirming product specification.
- This document shows difference, some specifications and standards, not for all. Be sure to refer to the most current data sheet as for the latest detailed specification and an electrical characteristics.

# 1. Difference among various products of 7560 Group

		One-time PROM version	Mask ROM version (Standard version)	Mask ROM version (A version)
ROM/RAM size[byte]		60K/2.5K	60K/2.5K, 32K/1K	←
Oscillation circuit constants		The oscillation circuit constants of XIN-XOUT, XCIN-XCOUT will depend on each product.		
Hysteresis characteristics (See 3.section)		Almost fixed	It depends on the power supply and becomes narrow.	←
Circuit structure of the peripheral function input pins		See 4.section		
sub-clock oscillation circuit		Without regulator	←	With regulator
Vpp power supply pin connection (P70)		Serial resistor (5k ohm) is necessary. Make the length of wiring which is connected to the Vpp pin as short as possible. It protects input noise.	Serial resistor is unnecessary.	←
Absolute Maximum ratings	Power source voltage(Vcc)	-0.3V to 7.0V	-0.3V to 6.5V	←
	Input voltage (C1, C2)			
	Output voltage (VL3)			
	Output voltage (C1, C2)			
	Input voltage (VL3)	VL2 to 7.0V	VL2 to 6.5V	←
Power source current		See 6.section		
Power supply(Vcc) / Main-clock input oscillation frequency		See 7.1. and 7.2. section		
RAM retention voltage (Min.)		2.0V	←	1.8V
Power source voltage of VLI (At using voltage multiplier)		1.3V to 2.3V	1.3V to 2.1V	←
Timer X,Y input frequency (Max.) f(CNTR0),f(CNTR1)		2.5<=Vcc<=4.0V : (4 x Vcc-1)/3 MHz 4.0<=Vcc<=5.5V : 4 MHz	2.2<=Vcc<=4.0V : (10 x Vcc-4)/9 MHz 4.0<=Vcc<=5.5V : 4 MHz	1.8<=Vcc<=2.0V : (5 x Vcc-8) MHz 2.0<=Vcc<=4.0V : (Vcc) MHz 4.0<=Vcc<=4.5V : (2 x Vcc-4) MHz 4.5<=Vcc<=5.5V : 5 MHz



The oscillation circuit constants of XIN-XOUT, XCIN-XCOUT will depend on each product of Mask ROM version (Standard version, A version) and One-Time PROM version.

So that the product used for mass production obtains the stabilized operation clock on the user system and its condition, contact the resonator manufacturer and select the resonator and oscillation circuit constants. Be careful especially when range of voltage and temperature is wide.

We recommend to design the circuit in consideration of the wiring pattern of the feed-back resistor, the dumping resistor and the load capacity in advance.

We publish the reference-use oscillation circuit parameters in Renesas Technology home page.

<http://www.renesas.com/en/38000>

# 3. Hysteresis characteristic

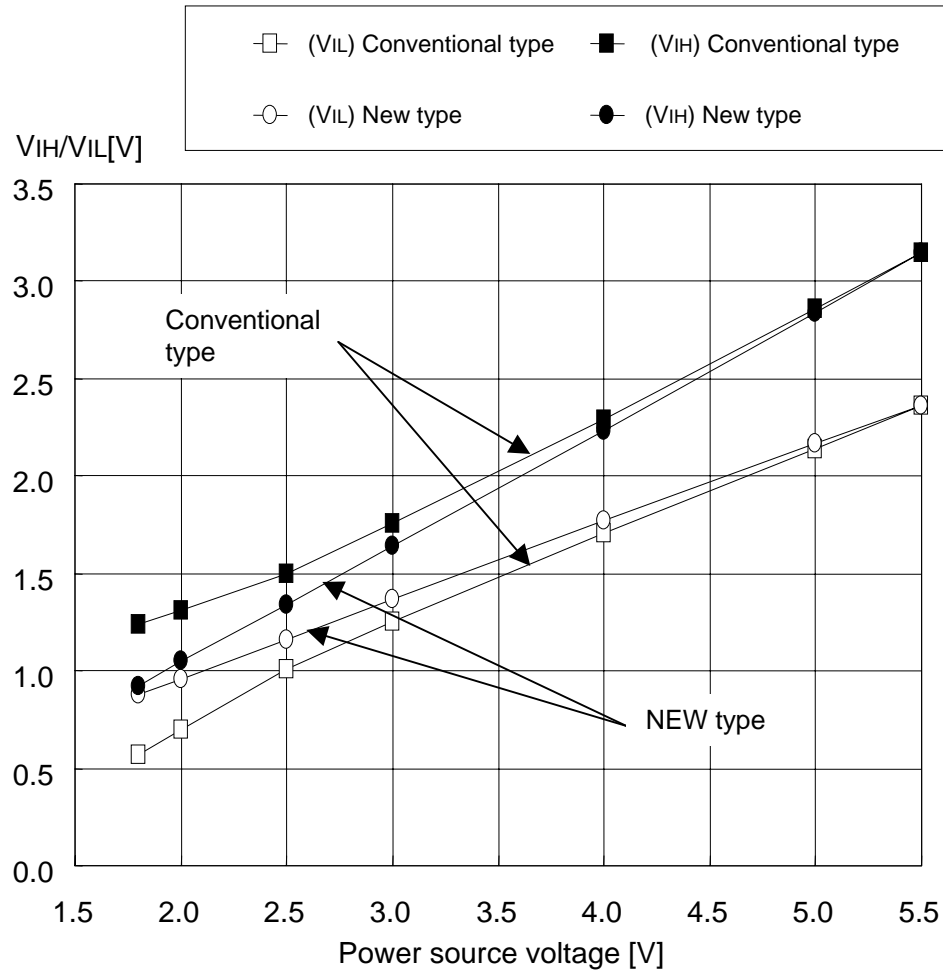

Note: Data described here are characteristic examples.  
The data values are not guaranteed.

		Conventional type	New type
Emulator MCU		○	
One-time PROM version		○	
Mask ROM version	Standard version		○
	A version		○

# 4. Circuit structure of the peripheral function input pins

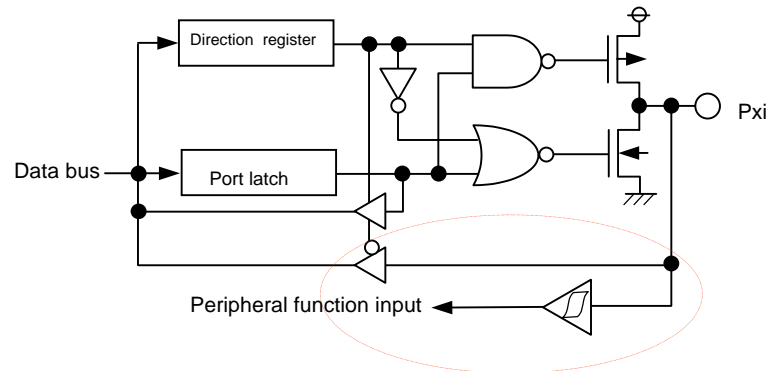

**Type A**

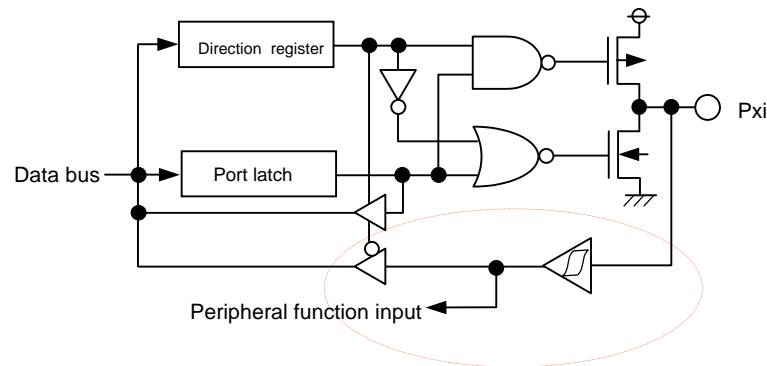

**Type B**

Type A : Input level of port does not always correspond with it of the peripheral function input pin.

Type B : Input level of port corresponds with it of the peripheral function input pin.  
(The port input also has hysteresis.)

		Type A	Type B
Emulator MCU		○	
One-time PROM version		○	
Mask ROM version	Standard version		○
	A version		○

Pins ;  
 P20 to P27, P41/INT1, P42/INT2, P44/RXD, P46/SCLK1,  
 P54/CNTR0, P55/CNTR1, P57/ADT, P60/SIN2, P62/SCLK21,  
 P70/INT0

# 5. LCD power supply pins

One-time PROM version

VL3 falling voltage =2.2V

VL3

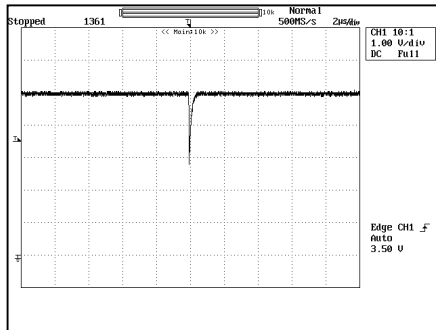

MASK ROM version (Standard version)

VL3 falling voltage =2.5V

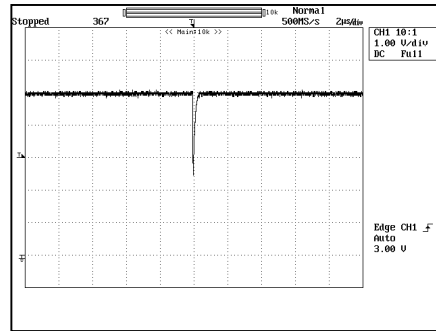

MASK ROM version (A version)

VL3 falling voltage =1.4V

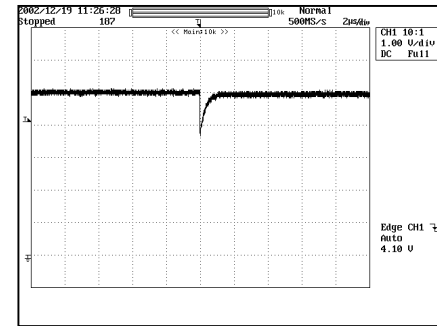

Note: Data described here are characteristic examples. The data values are not guaranteed.

<Measure condition>

- Only SEG exclusive pins output the LCD drive waveform.
- PORT pins shared with LCD outputs are selected as PORT function.
- COM and SEG pins are open.(No load)
- All data of LCDRAM is 55h.

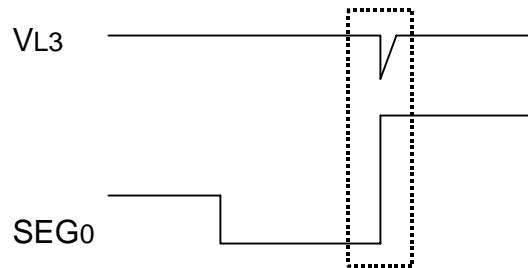

Voltage falling occurs in every LCDCK cycle

- (1) Shorten the wiring pattern in right diagram.
- (2) Connect condensers to the LCD power supply pin and Vss with the shortest possible wiring to steady voltage level. (reference value:0.1uF to 0.33uF).

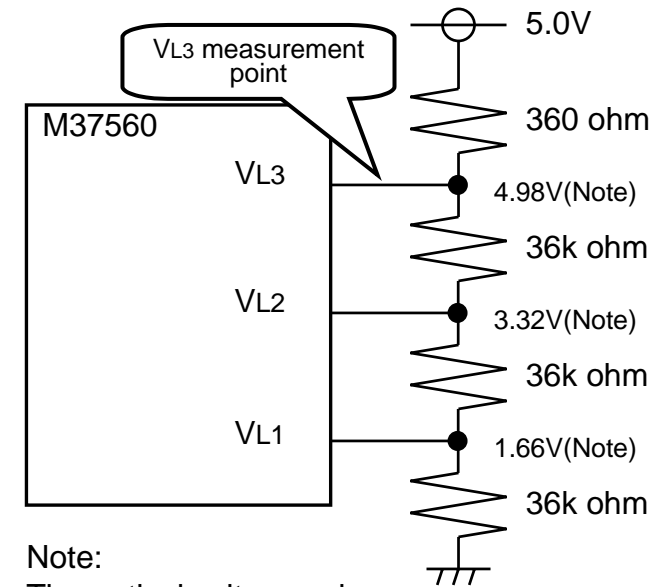

Note:  
Theoretical voltage value

## 6. Electrical characteristics (Power source current)

Symbol	Parameter	Test conditions	One-time PROM ver.		Mask ROM ver. (Standard ver.)		Mask ROM ver. (A version)		Unit
			Typ.	Max.	Typ.	Max.	Typ.	Max.	
I <sub>CC</sub>	Power source current	High-speed mode, V <sub>CC</sub> = 5V, f(XIN) = 10MHz, f(XCIN) = 32.768kHz Output transistors "off", A-D converter in operating	-	-	-	-	4.5	9.0	mA
		High-speed mode, V <sub>CC</sub> = 5V, f(XIN) = 8MHz, f(XCIN) = 32.768 kHz Output transistors "off", A-D converter in operating	6.4	13	6.4	13	4.0	8.0	mA
		High-speed mode, V <sub>CC</sub> = 5V, f(XIN) = 8MHz (in WIT state), f(XCIN) = 32.768kHz, Output transistors "off", A-D converter stop	1.6	3.2	1.6	3.2	0.9	1.8	mA
		Low-speed mode, V <sub>CC</sub> = 5V, T <sub>a</sub> = < 55 degrees C, f(XIN) = stopped f(XCIN) = 32.768kHz, Output transistors "off"	35	70	35	70	15	30	μA
		Low-speed mode, V <sub>CC</sub> = 5V, T <sub>a</sub> = 25 degrees C, f(XIN) = stopped f(XCIN) = 32.768kHz(in WIT state), Output transistors "off"	20	40	20	40	7	14	μA
		Low-speed mode, V <sub>CC</sub> = 3V, T <sub>a</sub> = < 55 degrees C, f(XIN) = stopped f(XCIN) = 32.768kHz, Output transistors "off"	15	22	15	22	9	18	μA
		Low-speed mode, V <sub>CC</sub> = 3V, T <sub>a</sub> = 25 degrees C, f(XIN) = stopped f(XCIN) = 32.768kHz(in WIT state), Output transistors "off"	4.5	9.0	4.5	9.0	4.5	9.0	μA
		All oscillation stopped (in STP state), T <sub>a</sub> = 25 degrees C, Output transistors "off"	0.1	1.0	0.1	1.0	0.1	1.0	μA
		All oscillation stopped (in STP state), T <sub>a</sub> = 85 degrees C, Output transistors "off"	-	10	-	10	-	10	μA



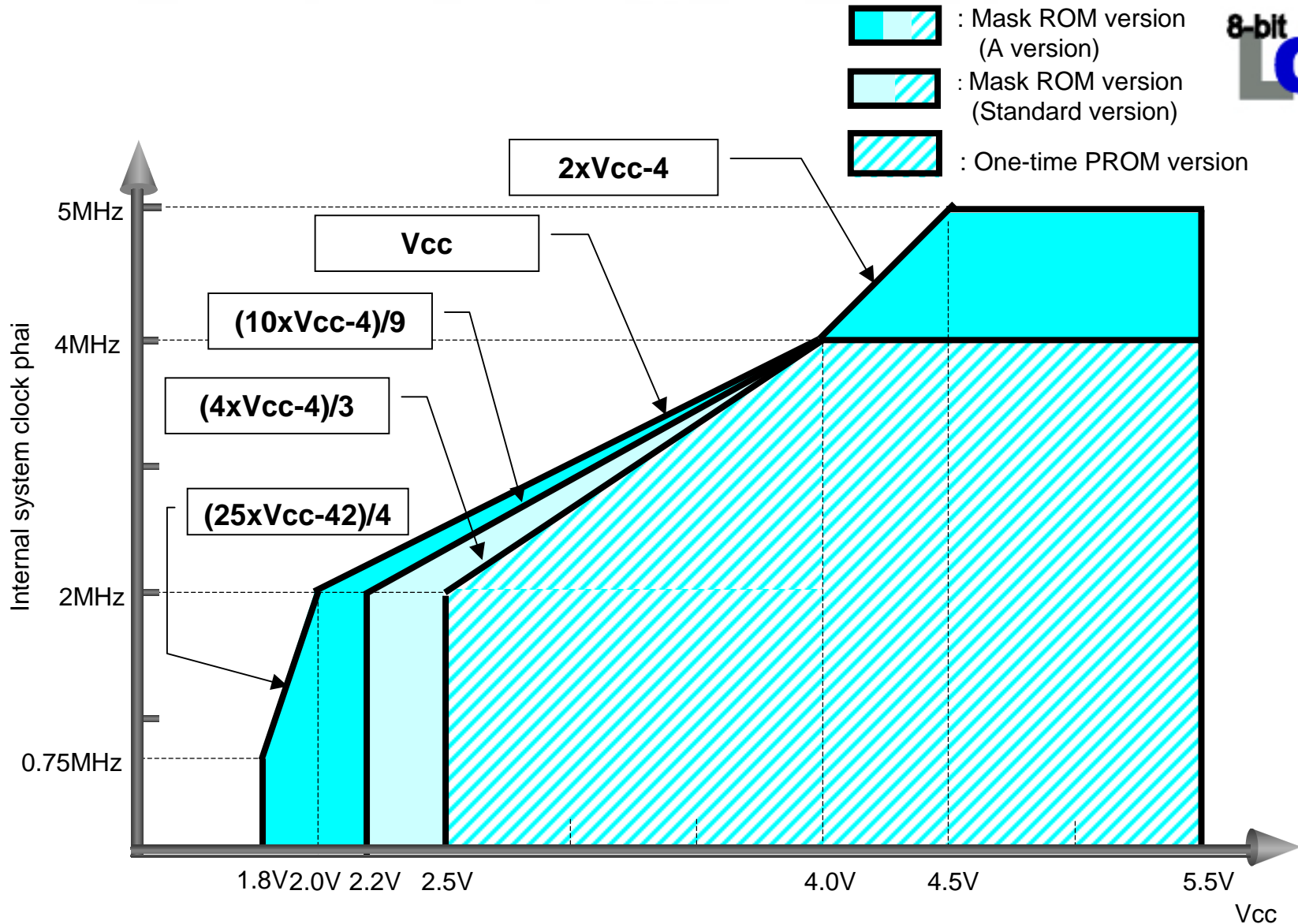

# 7.1. Internal-clock vs. Vcc (Except A-D converter)



## 7.2. External-clock vs. Vcc (A-D converter in operating)



-  : Mask ROM version (A version)
-  : Mask ROM version (Standard version)  
One-time PROM version

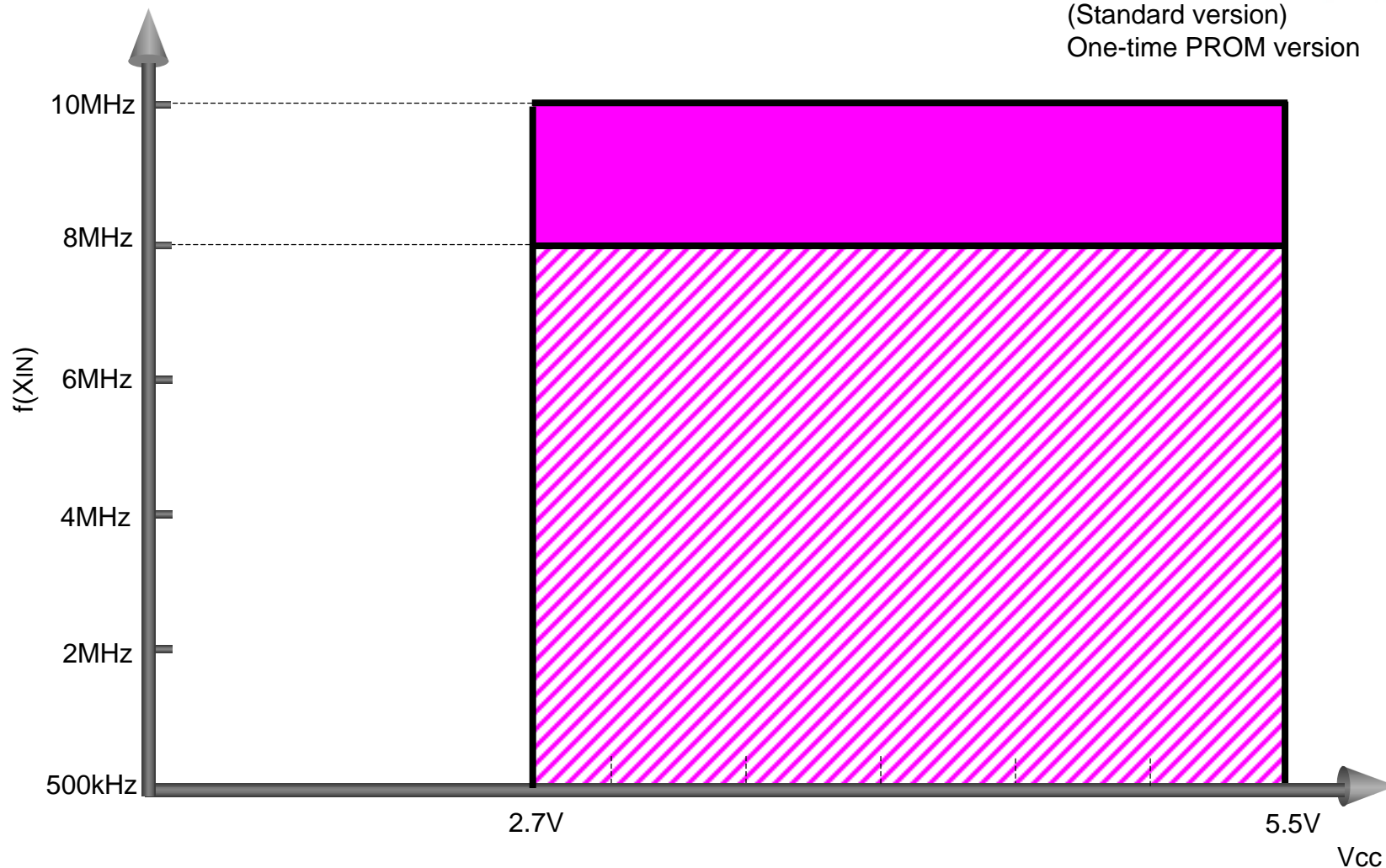

To our customers,

---

## Old Company Name in Catalogs and Other Documents

---

On April 1<sup>st</sup>, 2010, NEC Electronics Corporation merged with Renesas Technology Corporation, and Renesas Electronics Corporation took over all the business of both companies. Therefore, although the old company name remains in this document, it is a valid Renesas Electronics document. We appreciate your understanding.

Renesas Electronics website: <http://www.renesas.com>

April 1<sup>st</sup>, 2010  
Renesas Electronics Corporation

Issued by: Renesas Electronics Corporation (<http://www.renesas.com>)

Send any inquiries to <http://www.renesas.com/inquiry>.

## Notice

1. All information included in this document is current as of the date this document is issued. Such information, however, is subject to change without any prior notice. Before purchasing or using any Renesas Electronics products listed herein, please confirm the latest product information with a Renesas Electronics sales office. Also, please pay regular and careful attention to additional and different information to be disclosed by Renesas Electronics such as that disclosed through our website.
2. Renesas Electronics does not assume any liability for infringement of patents, copyrights, or other intellectual property rights of third parties by or arising from the use of Renesas Electronics products or technical information described in this document. No license, express, implied or otherwise, is granted hereby under any patents, copyrights or other intellectual property rights of Renesas Electronics or others.
3. You should not alter, modify, copy, or otherwise misappropriate any Renesas Electronics product, whether in whole or in part.
4. Descriptions of circuits, software and other related information in this document are provided only to illustrate the operation of semiconductor products and application examples. You are fully responsible for the incorporation of these circuits, software, and information in the design of your equipment. Renesas Electronics assumes no responsibility for any losses incurred by you or third parties arising from the use of these circuits, software, or information.
5. When exporting the products or technology described in this document, you should comply with the applicable export control laws and regulations and follow the procedures required by such laws and regulations. You should not use Renesas Electronics products or the technology described in this document for any purpose relating to military applications or use by the military, including but not limited to the development of weapons of mass destruction. Renesas Electronics products and technology may not be used for or incorporated into any products or systems whose manufacture, use, or sale is prohibited under any applicable domestic or foreign laws or regulations.
6. Renesas Electronics has used reasonable care in preparing the information included in this document, but Renesas Electronics does not warrant that such information is error free. Renesas Electronics assumes no liability whatsoever for any damages incurred by you resulting from errors in or omissions from the information included herein.
7. Renesas Electronics products are classified according to the following three quality grades: “Standard”, “High Quality”, and “Specific”. The recommended applications for each Renesas Electronics product depends on the product’s quality grade, as indicated below. You must check the quality grade of each Renesas Electronics product before using it in a particular application. You may not use any Renesas Electronics product for any application categorized as “Specific” without the prior written consent of Renesas Electronics. Further, you may not use any Renesas Electronics product for any application for which it is not intended without the prior written consent of Renesas Electronics. Renesas Electronics shall not be in any way liable for any damages or losses incurred by you or third parties arising from the use of any Renesas Electronics product for an application categorized as “Specific” or for which the product is not intended where you have failed to obtain the prior written consent of Renesas Electronics. The quality grade of each Renesas Electronics product is “Standard” unless otherwise expressly specified in a Renesas Electronics data sheets or data books, etc.
  - “Standard”: Computers; office equipment; communications equipment; test and measurement equipment; audio and visual equipment; home electronic appliances; machine tools; personal electronic equipment; and industrial robots.
  - “High Quality”: Transportation equipment (automobiles, trains, ships, etc.); traffic control systems; anti-disaster systems; anti-crime systems; safety equipment; and medical equipment not specifically designed for life support.
  - “Specific”: Aircraft; aerospace equipment; submersible repeaters; nuclear reactor control systems; medical equipment or systems for life support (e.g. artificial life support devices or systems), surgical implantations, or healthcare intervention (e.g. excision, etc.), and any other applications or purposes that pose a direct threat to human life.
8. You should use the Renesas Electronics products described in this document within the range specified by Renesas Electronics, especially with respect to the maximum rating, operating supply voltage range, movement power voltage range, heat radiation characteristics, installation and other product characteristics. Renesas Electronics shall have no liability for malfunctions or damages arising out of the use of Renesas Electronics products beyond such specified ranges.
9. Although Renesas Electronics endeavors to improve the quality and reliability of its products, semiconductor products have specific characteristics such as the occurrence of failure at a certain rate and malfunctions under certain use conditions. Further, Renesas Electronics products are not subject to radiation resistance design. Please be sure to implement safety measures to guard them against the possibility of physical injury, and injury or damage caused by fire in the event of the failure of a Renesas Electronics product, such as safety design for hardware and software including but not limited to redundancy, fire control and malfunction prevention, appropriate treatment for aging degradation or any other appropriate measures. Because the evaluation of microcomputer software alone is very difficult, please evaluate the safety of the final products or system manufactured by you.
10. Please contact a Renesas Electronics sales office for details as to environmental matters such as the environmental compatibility of each Renesas Electronics product. Please use Renesas Electronics products in compliance with all applicable laws and regulations that regulate the inclusion or use of controlled substances, including without limitation, the EU RoHS Directive. Renesas Electronics assumes no liability for damages or losses occurring as a result of your noncompliance with applicable laws and regulations.
11. This document may not be reproduced or duplicated, in any form, in whole or in part, without prior written consent of Renesas Electronics.
12. Please contact a Renesas Electronics sales office if you have any questions regarding the information contained in this document or Renesas Electronics products, or if you have any other inquiries.

(Note 1) “Renesas Electronics” as used in this document means Renesas Electronics Corporation and also includes its majority-owned subsidiaries.

(Note 2) “Renesas Electronics product(s)” means any product developed or manufactured by or for Renesas Electronics.