

THIS DOCUMENT CONTAINS DATA PROPRIETARY TO PROJECTS UNLIMITED, INC. ANY USE OR REPRODUCTION, IN ANY FORM, WITHOUT PRIOR WRITTEN PERMISSION OF PROJECTS UNLIMITED, INC. IS PROHIBITED.  
© 2003, Projects Unlimited Inc.

SPECIFICATIONS

| PARAMETERS               | VALUES     | UNITS |
|--------------------------|------------|-------|
| RESONANT FREQUENCY       | 4,000±500  | Hz    |
| RESONANT IMPEDANCE (MAX) | 350        | Ohm   |
| MAX INPUT VOLTAGE        | 30         | Vp-p  |
| CAPACITANCE @ 100Hz      | 25,000±30% | pF    |
| PLATE MATERIAL           | BRASS      | -     |
| OPERATING TEMPERATURE    | -20 ~ +60  | °C    |
| STORAGE TEMPERATURE      | -20 ~ +70  | °C    |

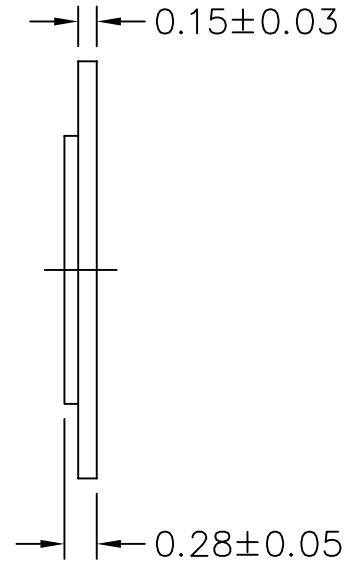
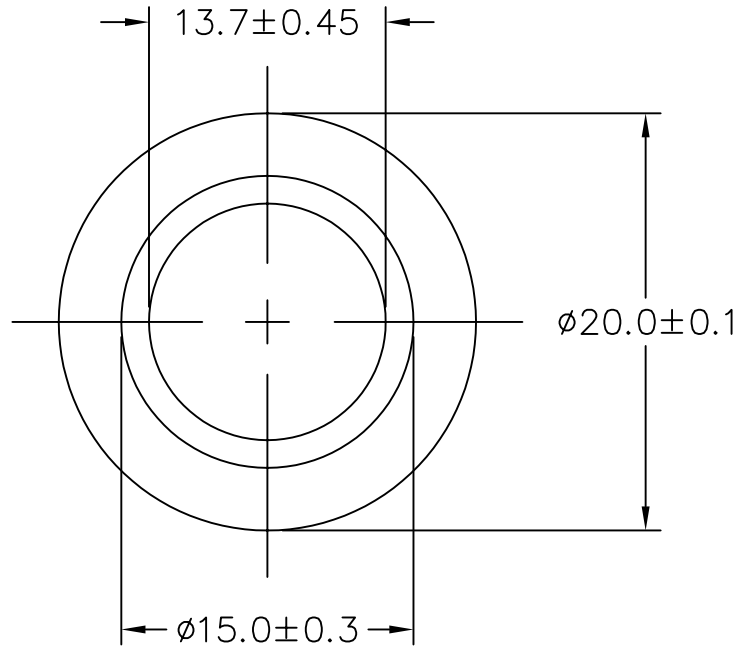

| REVISIONS |  |          |          |
|-----------|--|----------|----------|
| LTR       | DESCRIPTION  | DATE     | APPROVED |
| -         | RELEASED FROM ENGINEERING  | 11/6/01  |          |
| A         | REVISED TO NEW TEMPLATE  | 9/4/03   | R. W.    |
| B         | ADDED DIMENSION & TOLERANCES   | 1/7/04   | R. W.    |
| C         | REVISED SPECIFICATIONS   | 1/12/04  | R. W.    |
| D         | REVISED DIMENSION  | 1/28/04  | R. W.    |
| E         | REVISED DIMENSION  | 8/31/04  | R. W.    |
| F         | REVISED CAP. SPEC. FROM 1 KHz TO 100 Hz & THICKNESS TOL. FROM .02 TO .03 | 8/08/05  | R. W.    |
| E         | REVISED DIMENSION SIZE AND STYLE   | 12/21/05 | B. R.    |

NOTES:

1. ALL DIMENSIONS ARE IN MILLIMETERS.
2. SPECIFICATION SUBJECT TO CHANGE OR WITHDRAWAL WITHOUT NOTICE.

FILE NAME  
AB2040B.DWG

|   |              |  |                        |  |
|---|--------------|--|------------------------|--|
| UNLESS OTHERWISE SPECIFIED:<br>DIMENSIONS ARE IN MILLIMETERS; TOLERANCES ARE ±0.5 AND ANGLES ARE ±3°. |              |  <b>projects®<br/>unlimited</b> |                        | Dayton , Ohio                                      |
| APPROVALS   |              | DATE   |                        | PIEZO CERAMIC BENDER<br><br>DRAWING NO.<br>AB2040B |
| DRAWN   | <i>B. C.</i> | 5/03   |                        |  |
| APPROVED  | <i>S. J.</i> | 5/03   |                        |  |
| DO NOT SCALE DRAWING  |              | SIZE<br>A  | DRAWING NO.<br>AB2040B |  |
|   |              | SCALE: N.T.S.  | SHEET 1 OF 1           |  |