

SY56023R



Low Voltage 1.2V/1.8V/2.5V CML 2x2 Crosspoint Switch 6.4Gbps with Equalization

Preliminary

General Description

The SY56023R is a fully differential, low voltage 1.2V/1.8V/2.5V CML 2x2 crosspoint switch with input equalization. The SY56023R can process clock signals as fast as 4.5GHz or data patterns up to 6.4Gbps.

The differential input includes Micrel's unique, 3-pin input termination architecture that interfaces to CML differential signals, without any level-shifting or termination resistor networks in the signal path. The differential input can also accept AC-coupled LVPECL and LVDS signals. Input voltages as small as 200mV (400mV_{PP}) are applied before the 9", 18" or 27" FR4 transmission line. For AC-coupled input interface applications, an internal voltage reference is provided to bias the V_T pin. The outputs are CML, with extremely fast rise/fall times guaranteed to be less than 80ps.

The SY56023R operates from a 2.5V ±5% core supply and a 1.2V, 1.8V or 2.5V ±5% output supply and is guaranteed over the full industrial temperature range (-40°C to +85°C). The SY56023R is part of Micrel's high-speed, Precision Edge[®] product line.

Datasheets and support documentation can be found on Micrel's web site at: www.micrel.com.

Functional Block Diagram

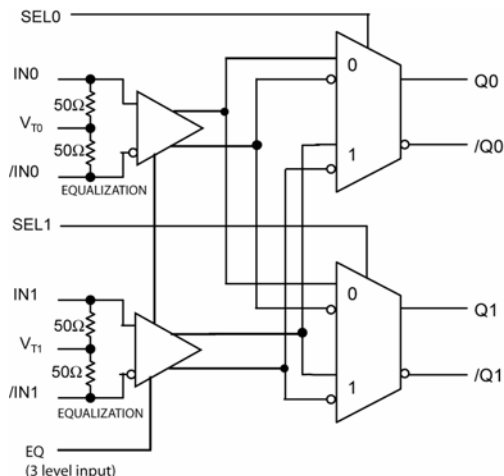

Precision Edge is a registered trademark of Micrel, Inc.
MLF and MicroLeadFrame are registered trademarks of Amkor Technology.



Precision Edge[®]

Features

- 1.2V/1.8V/2.5V CML 2x2 Crosspoint Switch
- Equalizes 9, 18, 27 inches of FR4
- Guaranteed AC performance over temperature and voltage:
 - DC-to > 6.4Gbps Data throughput
 - DC-to > 4.5GHz Clock throughput
 - <280 ps propagation delay (IN-to-Q)
 - <15 ps output skew
 - <80 ps rise/fall times
- Ultra-low jitter design
 - <1 ps_{RMS} cycle-to-cycle jitter
- High-speed CML outputs
- 2.5V ±5% V_{CC}, 1.2/1.8V/2.5V ±5% V_{CCO} power supply operation
- Industrial temperature range: -40°C to +85°C
- Available in 16-pin (3mm x 3mm) MLF[®] package

Applications

- Data Distribution:
- SONET clock and data distribution
- Fiber Channel clock and data distribution
- Gigabit Ethernet clock and data distribution

Markets

- Storage
- ATE
- Test and measurement
- Enterprise networking equipment
- High-end servers
- Metro area network equipment

Ordering Information⁽¹⁾

Part Number	Package Type	Operating Range	Package Marking	Lead Finish
SY56023RMG	MLF-16	Industrial	R023 with Pb-Free bar-line indicator	NiPdAu Pb-Free
SY56023RMGTR ⁽²⁾	MLF-16	Industrial	R023 with Pb-Free bar-line indicator	NiPdAu Pb-Free

Notes:

1. Contact factory for die availability. Dice are guaranteed at T_A = 25°C, DC Electricals only.
2. Tape and Reel.

Pin Configuration

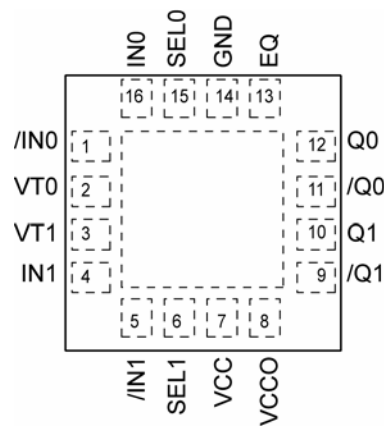

16-Pin MLF[®] (MLF-16)

Truth Table

SEL0	SEL1	Q0	Q1
L	L	IN0	IN0
L	H	IN0	IN1
H	L	IN1	IN0
H	H	IN1	IN1

EQ	EQUALIZATION
LOW	27"
FLOAT	18"
HIGH	9"

Pin Description

Pin Number	Pin Name	Pin Function
16,1 4,5	IN0, /IN0 IN1, /IN1	Differential Inputs: Signals as small as 200mV V_{PK} (400mV $_{PP}$) applied to the input of 9, 18 or 27 inches 6 mil FR4 stripline transmission line are then terminated with the differential input. Each input pin internally terminates with 50 Ω to the VT pin.
2 3	VT0 VT1	Input Termination Center-Tap: Each side of the differential input pair terminates to a VT pin. This pin provides a center-tap to a termination network for maximum interface flexibility. An internal high impedance resistor divider biases VT to allow input AC coupling. For AC-coupling, bypass VT with 0.1 μ F low ESR capacitor to VCC. See "Interface Applications" subsection and Figure 2a.
13	EQ	Three level input for equalization control. High, float, low. EQ pin applies the same EQ setting to both inputs.
15 6	SEL0 SEL1	These single-ended TTL/CMOS-compatible inputs, selects inputs IN0 or IN1. Note that these inputs are internally connected to a 25k Ω pull-up resistor and will default to a logic HIGH state if left open.
7	VCC	Positive Power Supply: Bypass with 0.1 μ F//0.01 μ F low ESR capacitors as close to the VCC pins as possible. Supplies input and core circuitry.
8	VCCO	Output Supply: Bypass with 0.1 μ F//0.01 μ F low ESR capacitors as close to the VCCO pins as possible. Supplies the output buffers
14	GND, Exposed pad	Ground: Exposed pad must be connected to a ground plane that is the same potential as the ground pins.
12,11 10,9	Q0, /Q0 Q1, /Q1	CML Differential Output Pairs: Differential buffered copy of the input signal. The output swing is typically 390mV. See "Interface Applications" subsection for termination information.

Absolute Maximum Ratings⁽¹⁾

Supply Voltage (V_{CC}) -0.5V to +3.0V
 Supply Voltage (V_{CCO}) -0.5V to +3.0V
 $V_{CC} - V_{CCO}$ <1.8V
 $V_{CCO} - V_{CC}$ <0.5V
 Input Voltage (V_{IN}) -0.5V to V_{CC}
 CML Output Voltage (V_{OUT}) 0.6V to 3.0V
 Current (V_T)
 Source or sink on VT pin ± 100 mA
 Input Current
 Source or sink Current on (IN, /IN) ± 50 mA
 Maximum operating Junction Temperature 125°C
 Lead Temperature (soldering, 20sec.) 260°C
 Storage Temperature (T_s) -65°C to +150°C

Operating Ratings⁽²⁾

Supply Voltage (V_{CC}) 2.375V to 2.625V
 (V_{CCO}) 1.14V to 2.625V
 Ambient Temperature (T_A) -40°C to +85°C
 Package Thermal Resistance⁽³⁾
 MLF[®]
 Still-air (θ_{JA}) 75°C/W
 Junction-to-board (ψ_{JB}) 33°C/W

DC Electrical Characteristics⁽⁴⁾

$T_A = -40^\circ\text{C}$ to $+85^\circ\text{C}$, unless otherwise stated.

Symbol	Parameter	Condition	Min	Typ	Max	Units
V_{CC}	Power Supply Voltage Range	V_{CC}	2.375	2.5	2.625	V
		V_{CCO}	1.14	1.2	1.26	V
		V_{CCO}	1.7	1.8	1.9	V
		V_{CCO}	2.375	2.5	2.625	V
I_{CC}	Power Supply Current	Max. V_{CC}		80	110	mA
I_{CCO}	Power Supply Current	No Load. V_{CCO}		32	42	mA
R_{IN}	Input Resistance (IN-to- V_T , /IN-to- V_T)		45	50	55	Ω
R_{DIFF_IN}	Differential Input Resistance (IN-to-/IN)		90	100	110	Ω
V_{IH}	Input HIGH Voltage (IN, /IN)	IN, /IN	1.42		V_{CC}	V
V_{IL}	Input LOW Voltage (IN, /IN)	IN, /IN 1.22V = 1.7-0.475	1.22		$V_{IH}-0.2$	V
V_{IN}	Input Voltage Swing (IN, /IN)	see Figure 3a, Note 5, applied to input of transmission line.	0.2		1.0	V
V_{DIFF_IN}	Differential Input Voltage Swing (IN - /IN)	see Figure 3b, Note 5, applied to input of transmission line.	0.4		2.0	V
V_{T_IN}	Voltage from Input to V_T				1.28	V

Notes:

1. Permanent device damage may occur if absolute maximum ratings are exceeded. This is a stress rating only and functional operation is not implied at conditions other than those detailed in the operational sections of this data sheet. Exposure to absolute maximum ratings conditions for extended periods may affect device reliability.
2. The data sheet limits are not guaranteed if the device is operated beyond the operating ratings.
3. Package thermal resistance assumes exposed pad is soldered (or equivalent) to the device's most negative potential on the PCB. ψ_{JB} and θ_{JA} values are determined for a 4-layer board in still-air number, unless otherwise stated.
4. The circuit is designed to meet the DC specifications shown in the above table after thermal equilibrium has been established.
5. $V_{IN(max)}$ is specified when V_T is floating.

CML Outputs DC Electrical Characteristics⁽⁶⁾

$V_{CCO} = 1.14V$ to $1.26V$ $R_L = 50\Omega$ to V_{CCO} ,

$V_{CCO} = 1.7V$ to $1.9V$, $2.375V$ to $2.625V$, $R_L = 50\Omega$ to V_{CCO} or 100Ω across the outputs,

$V_{CC} = 2.375V$ to $2.625V$; $T_A = -40^\circ C$ to $+85^\circ C$, unless otherwise stated.

Symbol	Parameter	Condition	Min	Typ	Max	Units
V_{OH}	Output HIGH Voltage	$R_L = 50\Omega$ to V_{CCO}	$V_{CCO}-0.020$	$V_{CCO}-0.010$	V_{CCO}	V
V_{OUT}	Output Voltage Swing	See Figure 3a	300	390	475	mV
V_{DIFF_OUT}	Differential Output Voltage Swing	See Figure 3b	600	780	950	mV
R_{OUT}	Output Source Impedance		45	50	55	Ω

LVTTL/CMOS DC Input Electrical Characteristics⁽⁶⁾

$V_{CC} = 2.375V$ to $2.625V$; $T_A = -40^\circ C$ to $+85^\circ C$, unless otherwise stated.

Symbol	Parameter	Condition	Min	Typ	Max	Units
V_{IH}	Input HIGH Voltage		2.0		V_{CC}	V
V_{IL}	Input LOW Voltage				0.8	V
I_{IH}	Input HIGH Current		-125		30	μA
I_{IL}	Input LOW Current		-300			μA

Three Level EQ Input DC Electrical Characteristics⁽⁶⁾

$V_{CC} = 2.375V$ to $2.625V$; $T_A = -40^\circ C$ to $+85^\circ C$, unless otherwise stated.

Symbol	Parameter	Condition	Min	Typ	Max	Units
V_{IH}	Input HIGH Voltage		$V_{CC}-0.3$		V_{CC}	V
V_{IL}	Input LOW Voltage		0		$V_{EE}+0.3$	V
I_{IH}	Input HIGH Current	$V_{IH} = V_{CC}$			400	μA
I_{IL}	Input LOW Current	$V_{IL} = GND$	-480			μA

Note:

6. The circuit is designed to meet the DC specifications shown in the above table after thermal equilibrium has been established.

AC Electrical Characteristics

$V_{CC0} = 1.14V$ to $1.26V$ $R_L = 50\Omega$ to V_{CC0} ,

$V_{CC0} = 1.7V$ to $1.9V$, $2.375V$ to $2.625V$, $R_L = 50\Omega$ to V_{CC0} or 100Ω across the outputs,

$V_{CC} = 2.375V$ to $2.625V$; $T_A = -40^\circ C$ to $+85^\circ C$, unless otherwise stated.

Symbol	Parameter	Condition	Min	Typ	Max	Units
f_{MAX}	Maximum Frequency	NRZ Data	6.4			Gbps
		$V_{OUT} > 200mV$ Clock	4.5			GHz
t_{PD}	Propagation Delay IN-to-Q SEL-to-Q	Note 7, Figure 1	100	180	280	ps
		Figure 1	90	210	350	ps
t_{Skew}	Input-to-Input Skew	Note 8			20	ps
	Output-to-Output Skew	Note 9			15	ps
	Part-to-Part Skew	Note 10			100	ps
t_{Jitter}	Random Jitter	Note 11			1	ps _{RMS}
	Crosstalk Induced Jitter (Adjacent Channel)	Note 12			0.7	ps _{PP}
t_R t_F	Output Rise/Fall Time (20% to 80%)	At full output swing.	20	50	80	ps

Notes:

- Propagation delay is measured with no attenuating transmission line connected to the input.
- Input-to-Input skew is the difference in time between both inputs and the output for the same temperature, voltage and transition.
- Output-to-Output skew is the difference in time between both outputs under identical input transition, temperature and power supply
- Part-to-part skew is defined for two parts with identical power supply voltages at the same temperature and no skew at the edges at the respective inputs.
- Random jitter is measured with a K28.7 pattern, measured at $\leq f_{MAX}$.
- Crosstalk induced jitter is defined as the added jitter that results from signals applied to the adjacent channel. It is measured at the output while applying a similar, differential clock frequencies that are asynchronous with respect to each other at the adjacent input.

Interface Applications

For Input Interface Applications see Figures 4a-e and for CML Output Termination see Figures 5a-d.

CML Output Termination with VCCO 1.2V

For VCCO of 1.2V, Figure 5a, terminate the output with 50 Ohms to 1.2V, not 100 ohms differentially across the outputs. If AC coupling is used, Figure 5d, terminate into 50 ohms to 1.2V before the coupling capacitor and then connect to a high value resistor to a reference voltage. Any unused output pair needs to be terminated, do not leave floating.

CML Output Termination with VCCO 1.8V

For VCCO of 1.8V, Figure 5a and Figure 5b, terminate with either 50 ohms to 1.8V or 100 ohms differentially across the outputs. AC- or DC-coupling is fine.

Input Termination

1.8V CML driver: Terminate input with VT tied to 1.8V. Don't terminate 100 ohms differentially.

2.5V CML driver: Terminate input with either VT tied to 2.5V or 100 ohms differentially.

The input cannot be DC coupled from a 1.2V CML driver.

Timing Diagrams

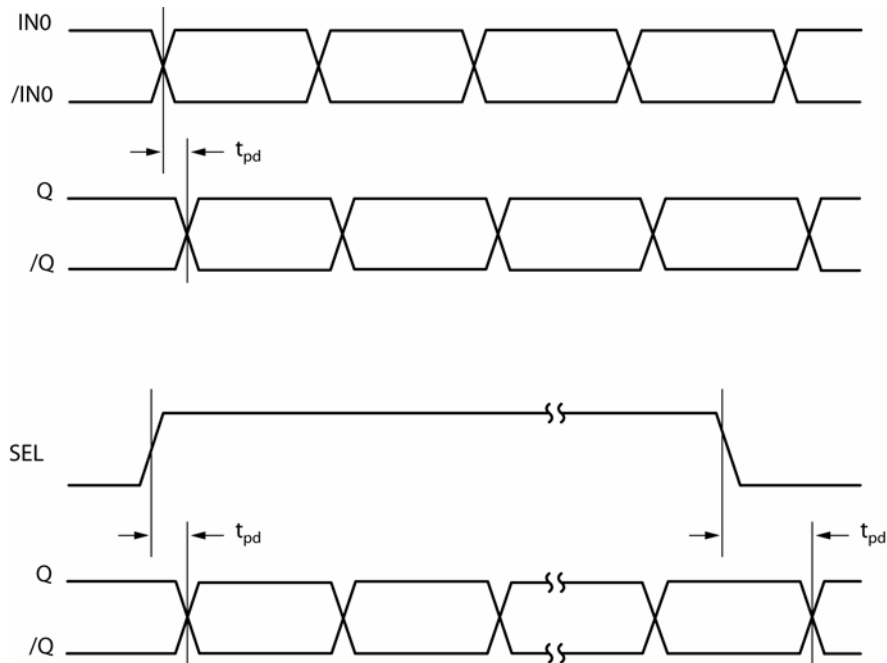
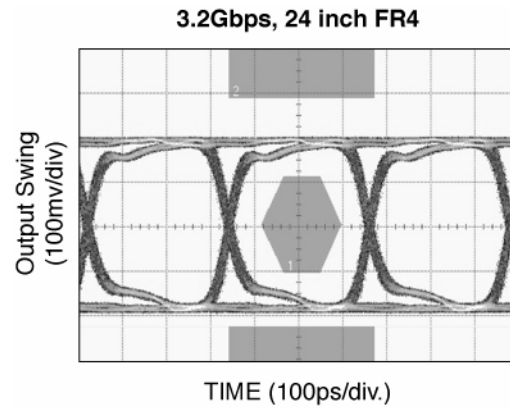
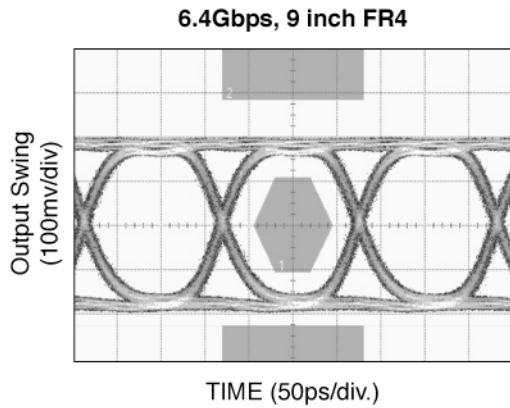
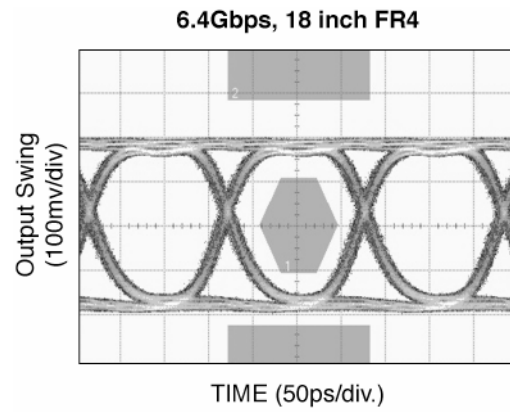
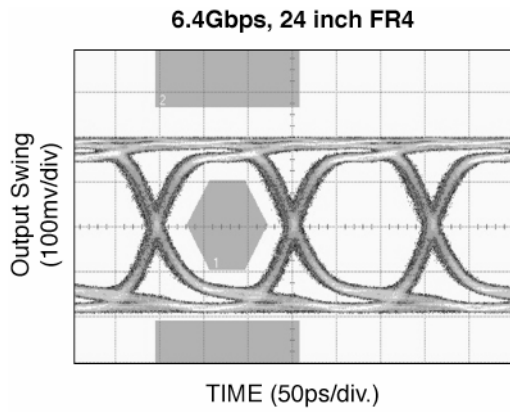

Figure 1. Propagation Delay

Typical Characteristics

$V_{CC} = 2.5$, $V_{CCO} = 1.2V$, $GND = 0V$, $V_{IN} = 400mV$, $R_L = 50\Omega$ to $1.2V$, Data Pattern: $2^{23}-1$, $T_A = 25^\circ C$, unless otherwise stated.



Input and Output Stage

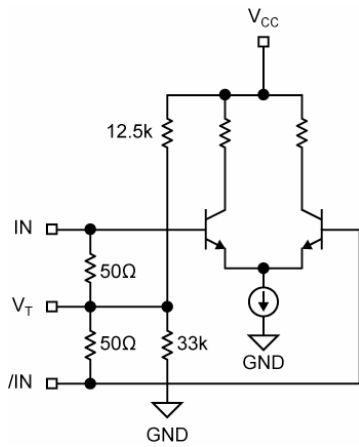

Figure 2a. Simplified Differential Input Buffer

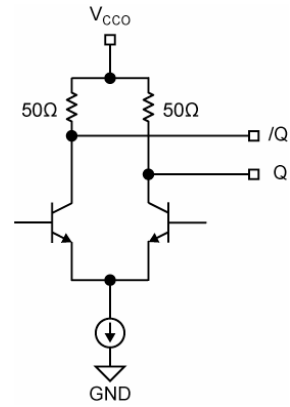

Figure 2b. Simplified CML Output Buffer

Single-Ended and Differential Swings

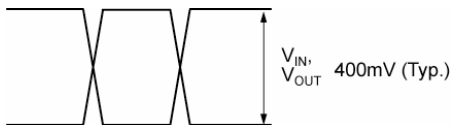

Figure 3a. Single-Ended Swing

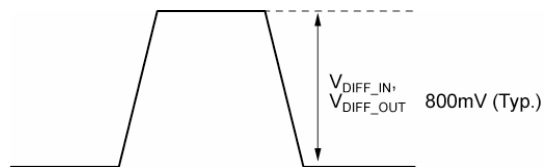

Figure 3b. Differential Swing

Input Interface Applications

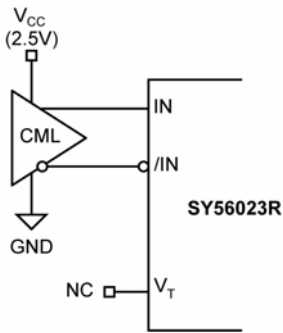

Figure 4a. CML Interface
100Ω Differential
(DC-Coupled, 2.5V)

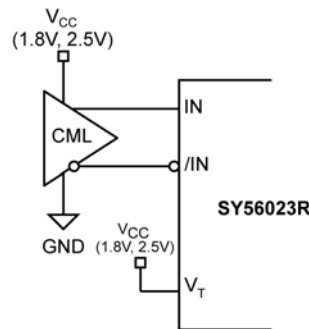

Figure 4b. CML Interface
50Ω to V_{CC}
(DC-Coupled, 1.8V, 2.5V)

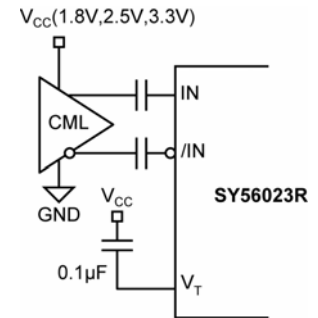

Figure 4c. CML Interface
(AC-Coupled)

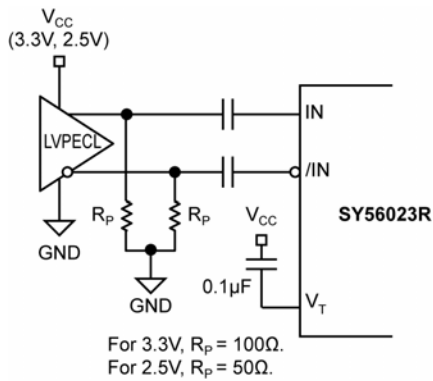

Figure 4d. LVPECL Interface
(AC-Coupled)

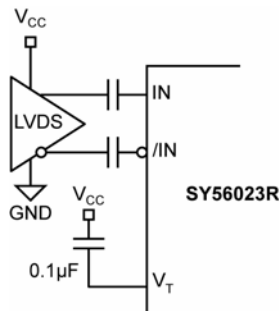
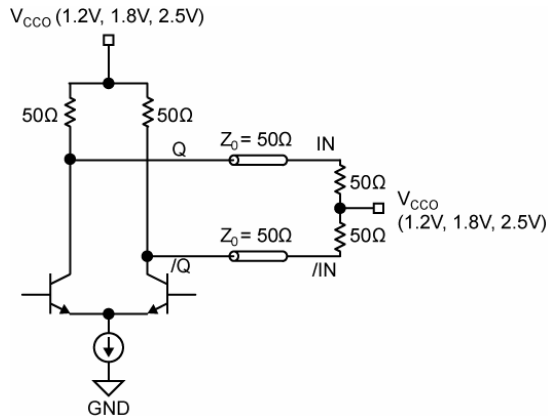
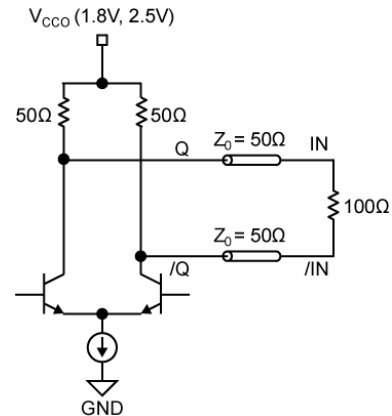

Figure 4e. LVDS Interface
(AC-Coupled)

CML Output Termination



**Figure 5a. 1.2V,1.8V, or 2.5V
CML DC-Coupled Termination**



**Figure 5b. 1.8V or 2.5V
CML DC-Coupled Termination**

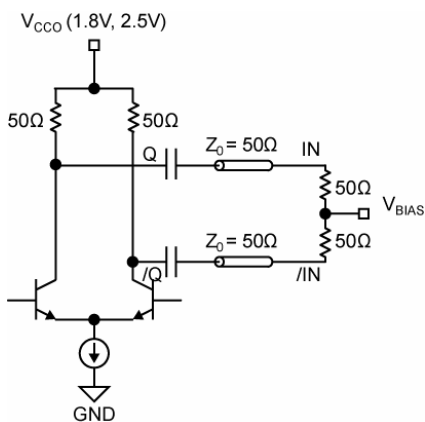

**Figure 5c. CML AC-Coupled Termination
Vcco 1.8V or 2.5V only**

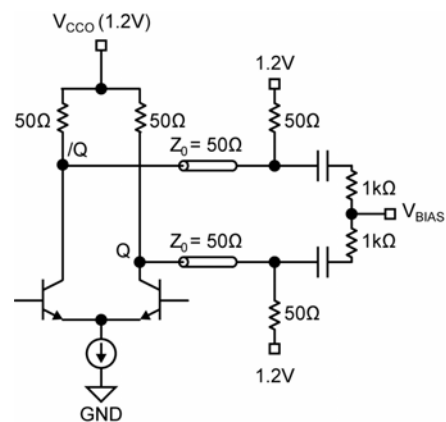
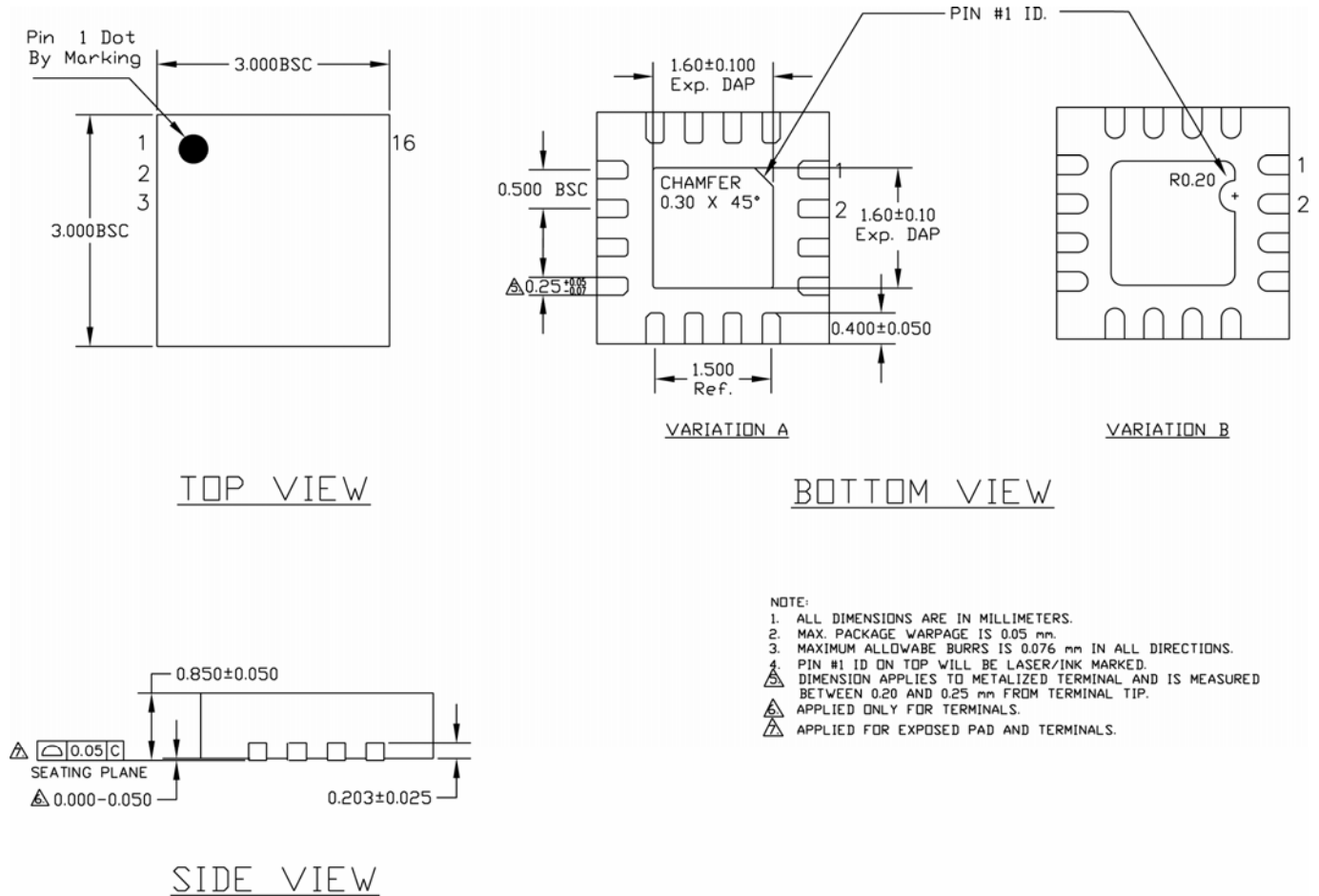

**Figure 5d. CML AC-Coupled Termination
Vcco 1.2V Only**

Related Product and Support Documents

Part Number	Function	Datasheet Link
HBW Solutions	New Products and Termination Application Notes	http://www.micrel.com/page.do?page=/product-info/as/HBWsolutions.shtml

Package Information



16-Pin MLF[®] (3mm x3mm) (MLF-16)

MICREL, INC. 2180 FORTUNE DRIVE SAN JOSE, CA 95131 USA
 TEL +1 (408) 944-0800 FAX +1 (408) 474-1000 WEB <http://www.micrel.com>

The information furnished by Micrel in this data sheet is believed to be accurate and reliable. However, no responsibility is assumed by Micrel for its use. Micrel reserves the right to change circuitry and specifications at any time without notification to the customer.

Micrel Products are not designed or authorized for use as components in life support appliances, devices or systems where malfunction of a product can reasonably be expected to result in personal injury. Life support devices or systems are devices or systems that (a) are intended for surgical implant into the body or (b) support or sustain life, and whose failure to perform can be reasonably expected to result in a significant injury to the user. A Purchaser's use or sale of Micrel Products for use in life support appliances, devices or systems is a Purchaser's own risk and Purchaser agrees to fully indemnify Micrel for any damages resulting from such use or sale.

© 2008 Micrel, Incorporated.