



SANYO Semiconductors

# DATA SHEET

## LA6358AM — Monolithic Digital IC High-Performance Dual Operational Amplifier

### Overview

The LA6358AM is a high-performance dual operational amplifier that can operate from a single voltage power supply (3 to 24 V) and over a wide operating temperature range (-40 to 125°C). It features a built-in phase correction circuit. It can also operate from a dual power supply with both positive and negative levels and features low power consumption. The LA6358AM can be used in a wide range of automotive and industrial applications as a transducer amplifier for all types of transducers, as a DC amplifier circuit, and for other purposes as well.

### Functions

- Phase correction not required
- Wide operating supply voltage range 3.0 V to 24.0 V (single power supply systems)  
±1.5 V to 12.0 V (dual power supply systems)
- The input voltage range extends to essentially the ground level, and furthermore the output voltage range for  $V_{OUT}$  is from 0 V to  $V_{CC} - 1.8$  V.
- Low current drain:  $I_{CC} = 0.5$  mA (typical) when  $V_{CC} = +5$  V,  $R_L = \infty$ .

### Specifications

#### Maximum Ratings at $T_a = -40^\circ\text{C}$ to $+125^\circ\text{C}$

Parameter	Symbol	Conditions	Ratings	Unit
Maximum supply voltage	$V_{CC}$ max		32	V
Differential input voltage	$V_{ID}$		32	V
Maximum input voltage	$V_{IN}$ max		-0.3 to +32	V
Allowable power dissipation	$P_d$ max	$T_a \leq 25^\circ\text{C}$	300	mW
Operating temperature	$T_{opr}$		-40 to +125	°C
Storage temperature	$T_{stg}$		-55 to +150	°C

#### Recommended Operating Conditions at $T_a = -40^\circ\text{C}$ to $+125^\circ\text{C}$

Parameter	Symbol	Conditions	Ratings			Unit
			min	typ	max	
Supply voltage	$V_{CC}$		3		24	V

■ Any and all SANYO Semiconductor products described or contained herein do not have specifications that can handle applications that require extremely high levels of reliability, such as life-support systems, aircraft's control systems, or other applications whose failure can be reasonably expected to result in serious physical and/or material damage. Consult with your SANYO Semiconductor representative nearest you before using any SANYO Semiconductor products described or contained herein in such applications.

■ SANYO Semiconductor assumes no responsibility for equipment failures that result from using products at values that exceed, even momentarily, rated values (such as maximum ratings, operating condition ranges, or other parameters) listed in products specifications of any and all SANYO Semiconductor products described or contained herein.

**SANYO Semiconductor Co., Ltd.**

TOKYO OFFICE Tokyo Bldg., 1-10, 1 Chome, Ueno, Taito-ku, TOKYO, 110-8534 JAPAN

# LA6358AM

**Electrical Characteristics** (Unless specified otherwise, the conditions are  $T_a = -40^{\circ}\text{C}$  to  $+125^{\circ}\text{C}$ ,  $V_{CC} = 5\text{ V}$ )

Parameter	Symbol	Conditions	Ratings			Unit
			min	typ	max	
Input offset voltage	$V_{IO}$			$\pm 2$	$\pm 7$	mV
Input offset current	$I_{IO}$	$I_{IN^+}/I_{IN^-}$		$\pm 5$	$\pm 50$	nA
Input bias current	$I_B$	$I_{IN^+}/I_{IN^-}$		45	250	nA
Common-mode input voltage range	$V_{ICM}$		0		$V_{CC}-1.8$	V
Common-mode rejection ratio	CMR	$V_{CC} = 30\text{ V}$	65	80		dB
Large-amplitude voltage gain	VG	$V_{CC} = 15\text{ V}$ , $R_L \geq 2\text{ k}\Omega$	25	100		V/mV
Output voltage range	$V_{OUT}$		0		$V_{CC}-1.8$	V
Supply voltage rejection ratio	SVR		65	100		dB
Channel separation	CH sep	$f = 1\text{ k}$ to $20\text{ kHz}$		120		dB
Current drain	$I_{CC}$			0.5	1.2	mA
Output current (source)	$I_{O\text{ source}}$	$V_{IN^+} = 1\text{ V}$ , $V_{IN^-} = 0\text{ V}$	10	20		mA
Output current (sink)	$I_{O\text{ sink}}$	$V_{IN^+} = 0\text{ V}$ , $V_{IN^-} = 1\text{ V}$	7	20		mA

## Package Dimensions

unit: mm  
3032C

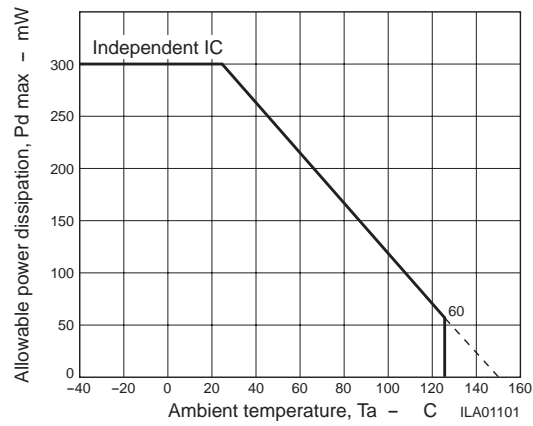
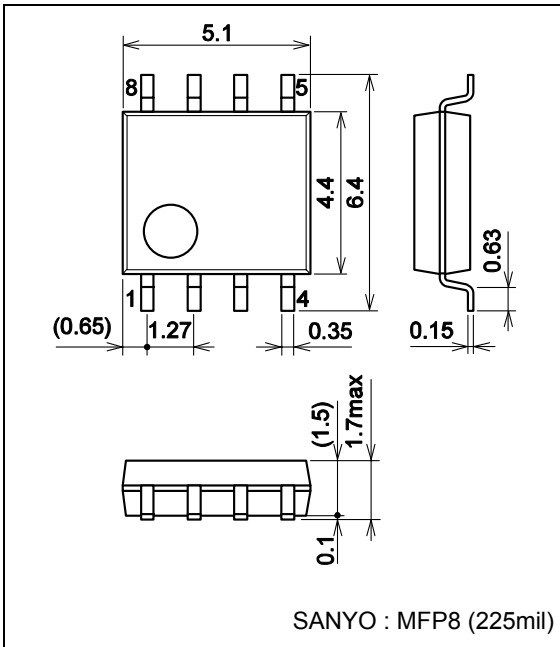

## Pin Assignment

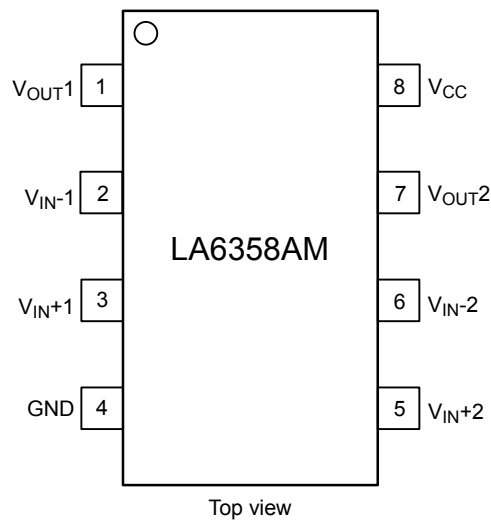

# LA6358AM

## Equivalent Circuit

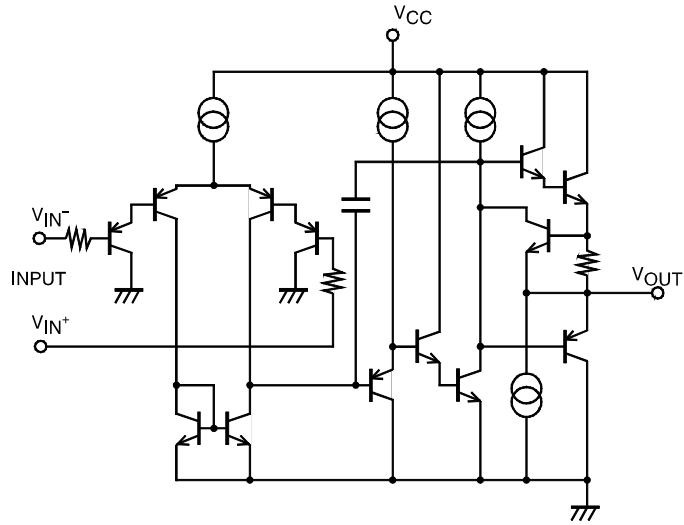

ILA01065

## Test Circuits

### 1. Input offset voltage VIO

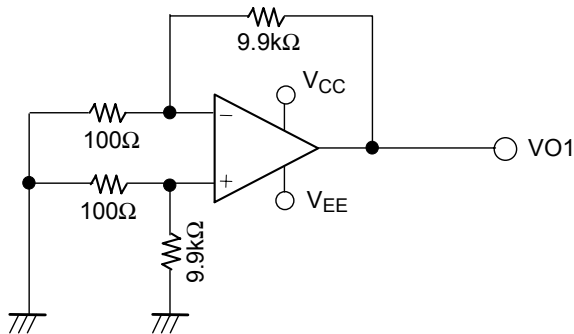

$$V_{CC}/V_{EE} = \pm 15V$$

$$V_{IO} = VO1/100$$

### 2. Input offset current IIO

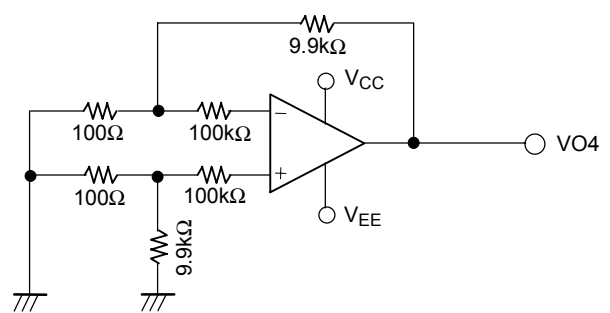

$$I_{IO} = \frac{|VO4 - VO1|}{100k\Omega \times 100}$$

### 3. Input bias current IB (-)

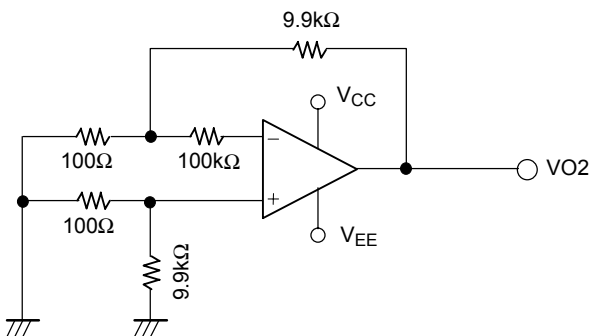

$$I_{B(-)} = \frac{|VO2 - VO1|}{100k\Omega \times 100}$$

### 4. Input bias current IB (+)

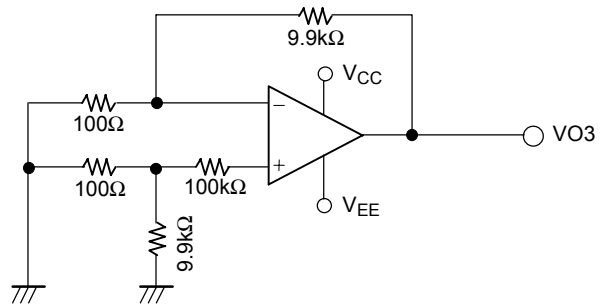

$$I_{B(+)} = \frac{|VO3 - VO1|}{100k\Omega \times 100}$$

# LA6358AM

## 5. Common-mode rejection ratio CMR Common-mode input voltage range VICN

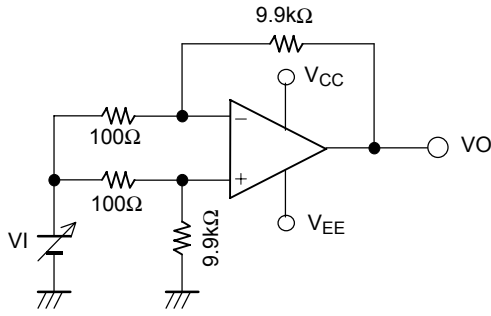

$$\text{CMR } V_I = \pm 7.5\text{V}$$

$$\text{CMR} = 20 \log \frac{15 \times 100}{|\Delta V_O|}$$

## 6. Voltage gain VG

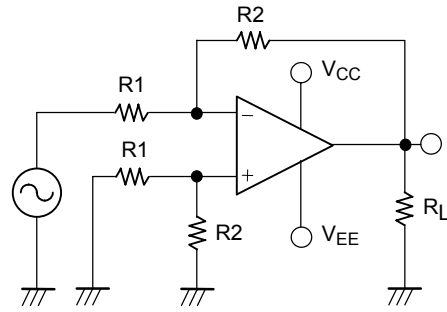

$$V_G = \frac{R_2}{R_1}$$

## 7. Channel separation CH sep

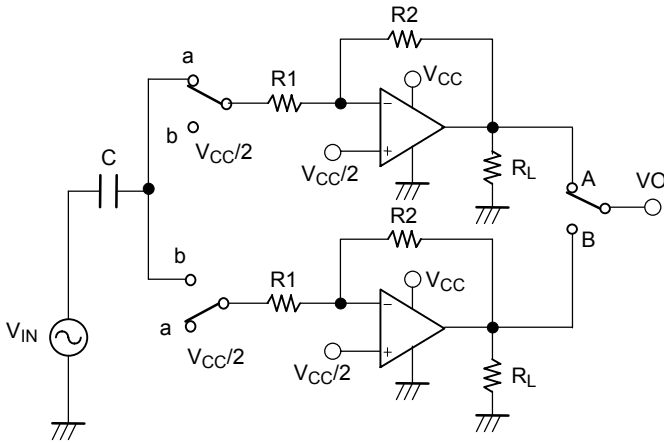

When the switch is in the "a" position

$$\text{CH sep}(A \rightarrow B) = 20 \log \frac{R_2 V_{OA}}{R_1 V_{OB}}$$

When the switch is in the "b" position

$$\text{CH sep}(B \rightarrow A) = 20 \log \frac{R_2 V_{OB}}{R_1 V_{OA}}$$

## 8. Current drain ICC

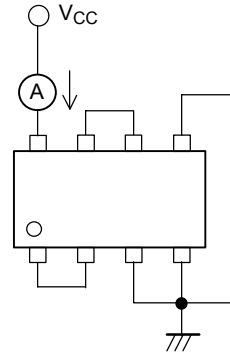

## 9. Output current IO source

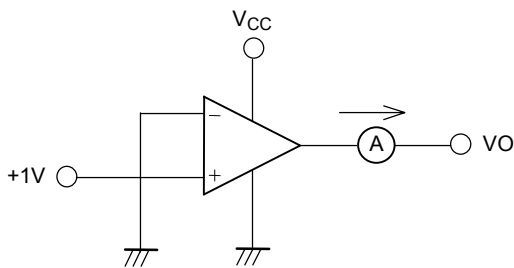

## 10. Output current IO sink

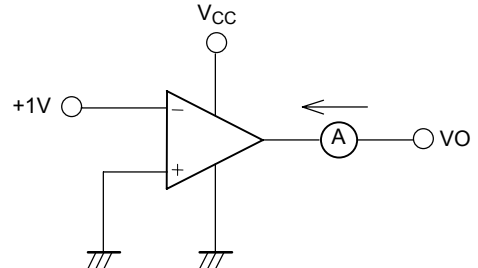

# LA6358AM

## 11. Supply voltage rejection ratio SVR (+)

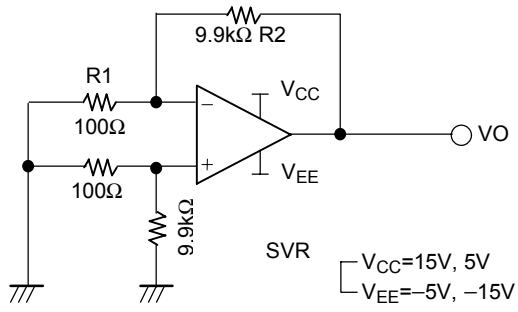

$$SVR(+) = 20 \log \left| \frac{\Delta V_{CC} \times 100}{\Delta VO} \right|$$

## 12. Supply voltage rejection ratio SVR (-)

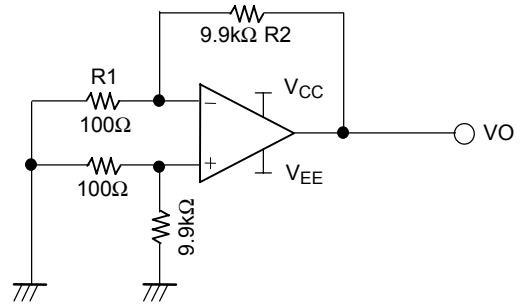

$$SVR(-) = 20 \log \left| \frac{\Delta V_{EE} \times 100}{\Delta VO} \right|$$

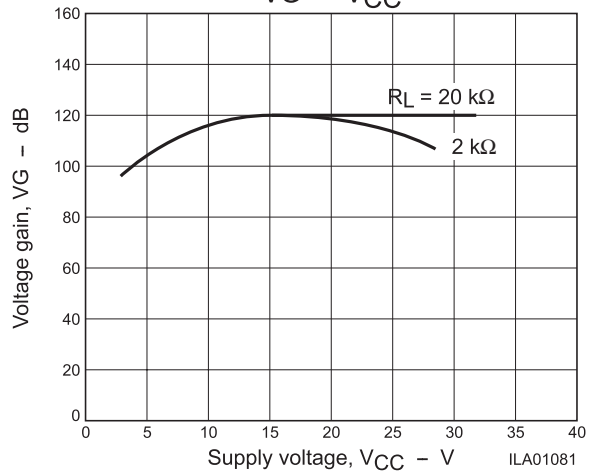
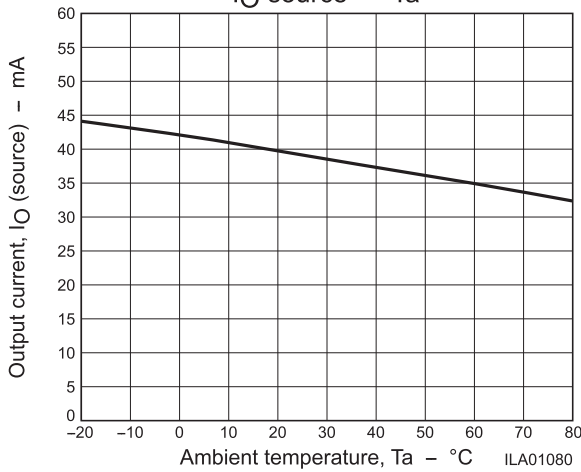
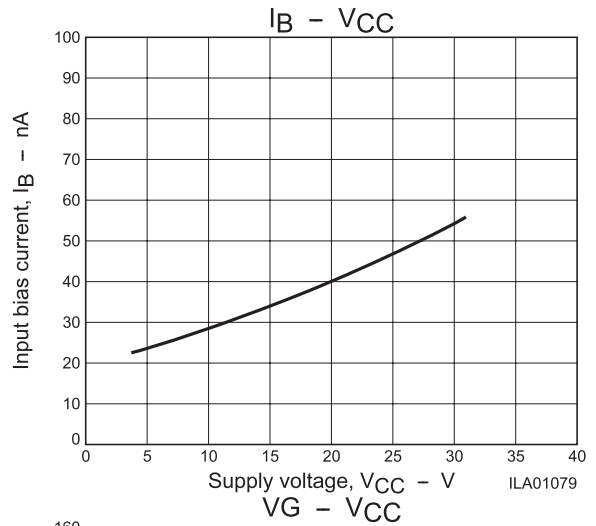
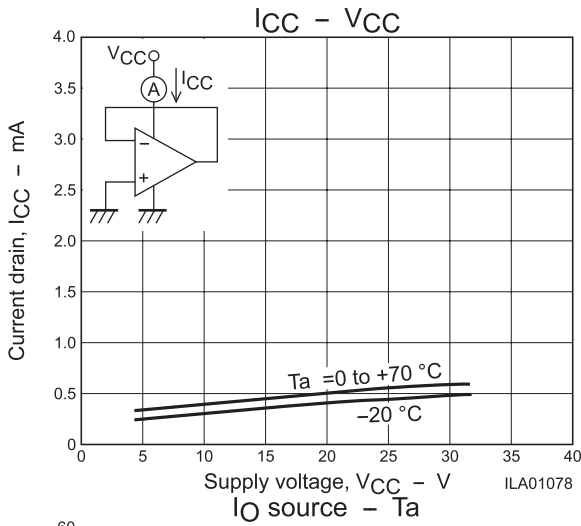

# LA6358AM

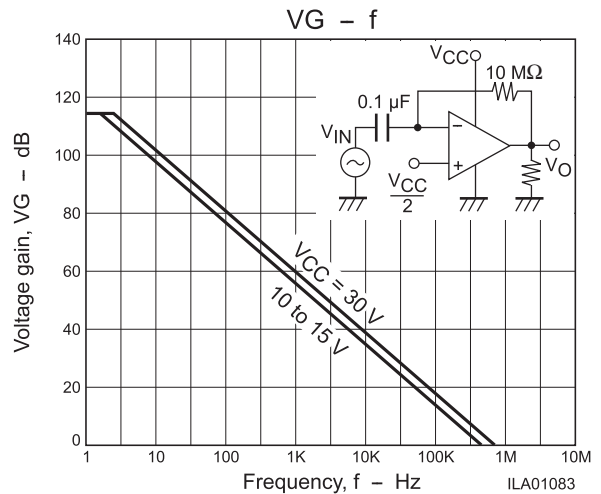
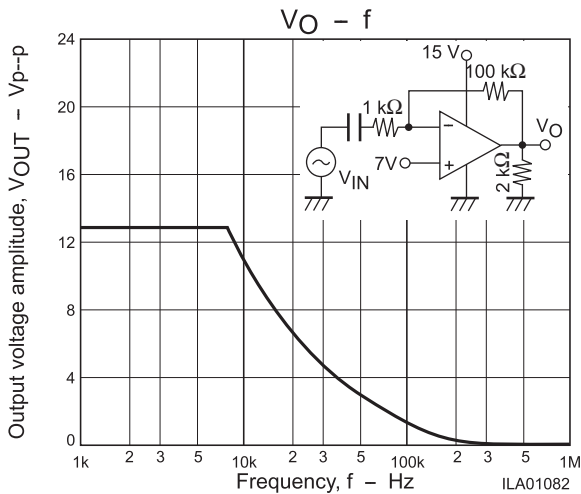

- Specifications of any and all SANYO Semiconductor products described or contained herein stipulate the performance, characteristics, and functions of the described products in the independent state, and are not guarantees of the performance, characteristics, and functions of the described products as mounted in the customer's products or equipment. To verify symptoms and states that cannot be evaluated in an independent device, the customer should always evaluate and test devices mounted in the customer's products or equipment.
- SANYO Semiconductor Co., Ltd. strives to supply high-quality high-reliability products. However, any and all semiconductor products fail with some probability. It is possible that these probabilistic failures could give rise to accidents or events that could endanger human lives, that could give rise to smoke or fire, or that could cause damage to other property. When designing equipment, adopt safety measures so that these kinds of accidents or events cannot occur. Such measures include but are not limited to protective circuits and error prevention circuits for safe design, redundant design, and structural design.
- In the event that any or all SANYO Semiconductor products (including technical data, services) described or contained herein are controlled under any of applicable local export control laws and regulations, such products must not be exported without obtaining the export license from the authorities concerned in accordance with the above law.
- No part of this publication may be reproduced or transmitted in any form or by any means, electronic or mechanical, including photocopying and recording, or any information storage or retrieval system, or otherwise, without the prior written permission of SANYO Semiconductor Co., Ltd.
- Any and all information described or contained herein are subject to change without notice due to product/technology improvement, etc. When designing equipment, refer to the "Delivery Specification" for the SANYO Semiconductor product that you intend to use.
- Information (including circuit diagrams and circuit parameters) herein is for example only; it is not guaranteed for volume production. SANYO Semiconductor believes information herein is accurate and reliable, but no guarantees are made or implied regarding its use or any infringements of intellectual property rights or other rights of third parties.

This catalog provides information as of August, 2004. Specifications and information herein are subject to change without notice.