

Dialight



**LOW
WATTAGE**



433 LED Rail Crossing Signal Module

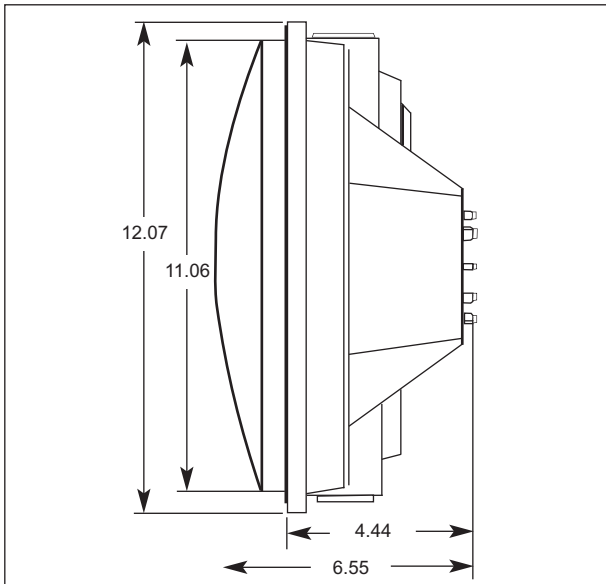

Features & Benefits

- 5 year full performance warranty
- AC / DC operation from 8 to 16 volts full output (operation down to 5 volts)
- Side light indicators reflect main beam signal for extra safety
- Designed for retrofit into existing lamp housings with no beam alignment necessary
- Ring terminations easily attach to AREMA posts
- Red tinted, UV-stabilized, and hard-coated lens for extended life
- Better visibility and faster response time than incandescent
- ARMA only and TC/AREMA versions
- Significantly reduced power consumption & current draw
- Years of maintenance-free operation
- FCC compliant for EMI

Application:

The state-of-the-art 433 series LED rail crossing signal was developed by Dialight to lower power requirements and maintenance costs; while increasing safety, life and reliability in rail crossing applications.

These lamps were designed utilizing Dialight's proven LED traffic signal technology to provide superior light performance for use on both existing and new crossing light applications. Safer fast on/off response time and brilliant monochromatic color makes these LED lamps more noticeable than incandescent lamps. The modular lamps install easily without special tools and operate in both AC and DC applications.

This light is unique from other LED crossing Lights in several ways: (1) Diffused lens and uniform appearance are similar to incandescent, (2) the lamp maintains the specified light output down to 8 volts, but operates down as low as 5 volts, and (3) safety is increased by side lights that monitor the main light beam by reflecting light via patented light pipe technology to ensure train engineers that the light aspect facing the street is actually flashing, providing two less failure points compared to any other competitor product.

Electrical specifications

Operating Voltage:	8 - 16 volts AC/DC
Operating Current:	1A @ 10VDC (XLTC) 0.75A @ 10VDC (XLA)
Operating Temp:	-40°F to +158°F (-40°C to +70°C)
AC Power Factor:	> 0.9

Photometric Information

Chromaticity:	$y \geq 0.330$ and $y \leq 0.998 - x$
---------------	---------------------------------------

Part Number	Size	Voltage	Compliance
433-1216-802XLA	12"	8-16VDC	AREMA
433-1216-101XLTC	12"	8-16VDC	AREMA / Transport Canada

433 LED Rail Crossing Signal Module

Rail Crossing Input Current / Output Intensity vs Input Voltage - XLA Version

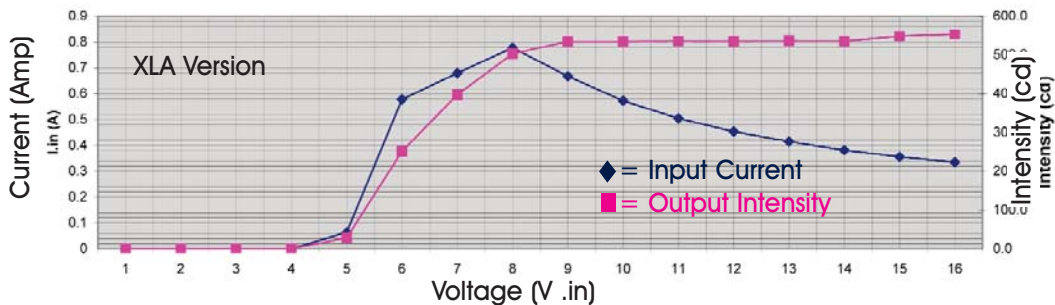

Isotropic Light Intensity (cd)

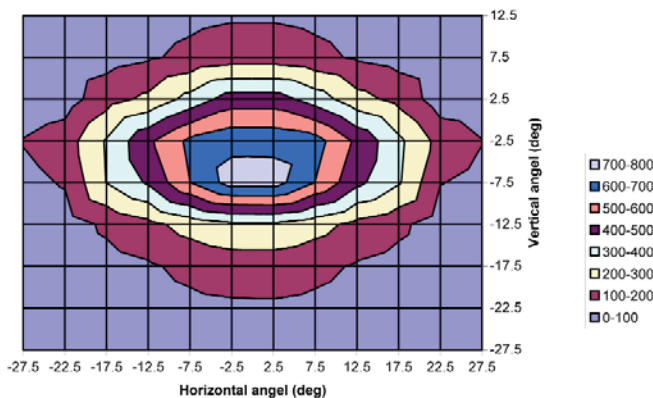

Rail Crossing Input Current / Output Intensity vs Input Voltage - XLTA Version

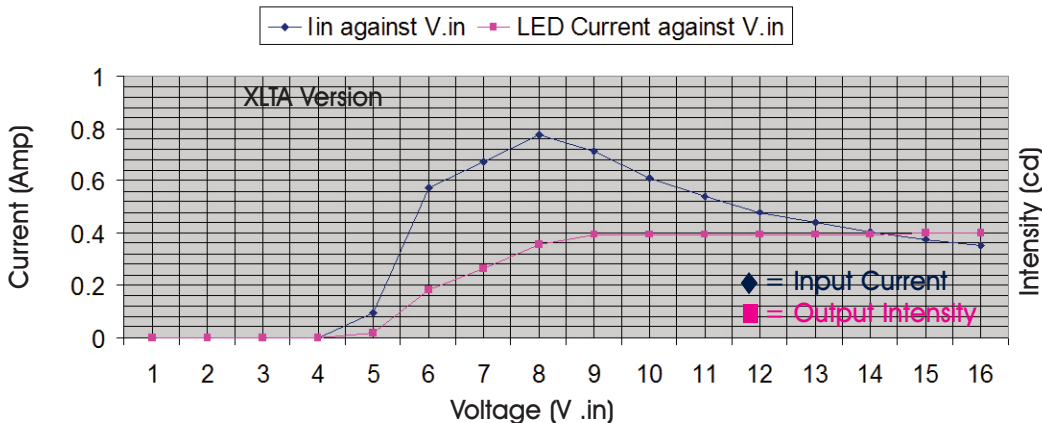

Isotropic Light Intensity (cd)

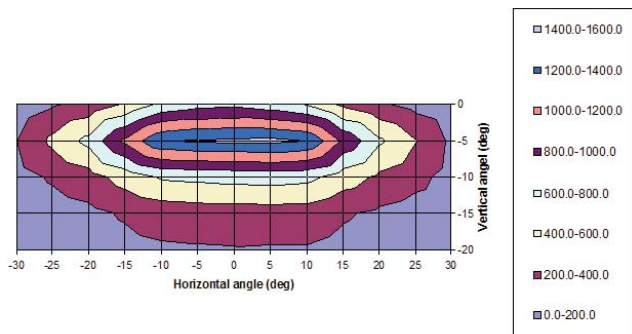

Dialight reserves the right to make changes at any time in order to supply the best product possible. The most current version of this document will always be available at: http://www.dialight.com/Assets/Brochures_And_Catalogs/Signaling/MDTRSCMX001.pdf