

DATA SHEET

SKY65004: 250 – 2700 MHz Linear Power Amplifier Driver

Applications

- UHF TV broadcasts
- TETRA radios
- GSM450, GSM480, GSM750 handsets
- AMPS, PCS, DCS, 2.5G, 3G handsets
- ISM band transmitters
- WCS fixed wireless
- 802.11b/g WLANs

Features

- Wideband frequency range: 250 to 2700 MHz
- High linearity: OIP3 > +40 dBm and P1dB > +24 dBm
- High efficiency: PAE 48%
- High gain: 20 dB
- Single DC supply, +3 V or +5 V
- Low-cost, SMT SOT-89 (4-pin, 2.4 x 4.5 mm) package

Description

Skyworks SKY65004 is a high performance, ultra-wideband amplifier with superior output power, linearity, and efficiency. The device is fabricated using Skyworks high reliability Aluminum Gallium Arsenide (AlGaAs) Heterojunction Bipolar Transistor (HBT) technology.

The SKY65004 achieves a high linearity and superior Adjacent Channel Power Rejection/Adjacent Channel Leakage Power Ratio (ACPR/ACLR) performance. This makes it ideal for use in the driver stage of infrastructure transmit chains for Trans-European Trunked Radio (TETRA) transceivers, multi-band (GSM, AMPS, PCS, DCS) handsets, and many other wireless applications.

The SKY65004 uses low-cost Surface-Mount Technology (SMT) in the form of a 4-pin, 2.4 x 4.5 mm Small Outline Transistor (SOT) package, which allows for a highly manufacturable low-cost solution. The device package and pinout are shown in Figure 1. Figure 2 shows a functional block diagram for the SKY65004.

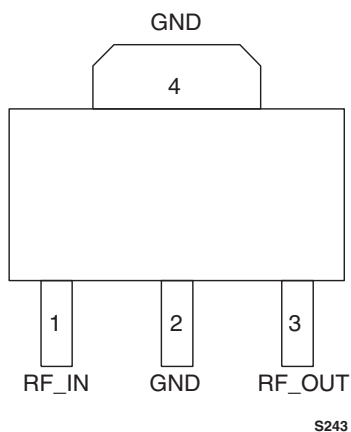

Figure 1. SKY65004 Pinout – 4-Pin SOT-89 Package (Top View)

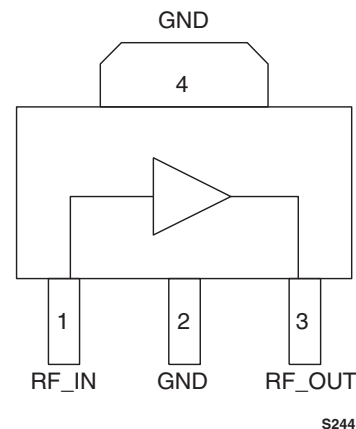

Figure 2. SKY65004 Functional Block Diagram

Electrical and Mechanical Specifications

Signal pin assignments and functional pin descriptions are provided in Table 1. The absolute maximum ratings of the SKY65004 are provided in Table 2 and the recommended operating conditions provided in Table 3. Electrical characteristics of the SKY65004 are provided in Table 4.

The typical performance of the SKY65004 is illustrated in Figures 3 through 13. Figure 23 provides the package dimensions for the 4-pin SOT-89 device, and Figure 24 provides the tape and reel dimensions.

Package and Handling Information

Since the device package is sensitive to moisture absorption, it is baked and vacuum packed before shipping. Instructions on the shipping container label regarding exposure to moisture after the container seal is broken must be followed. Otherwise, problems related to moisture absorption may occur when the part is subjected to high temperature during solder assembly.

If the part is attached in a reflow oven, the temperature ramp rate should not exceed 5 °C per second. Maximum temperature should not exceed 225 °C and the time spent at a temperature that exceeds 210 °C should be limited to less than 10 seconds. If the part is manually attached, precaution should be taken to ensure that the part is not subjected to a temperature that exceeds 300 °C for more than 10 seconds.

Care must be taken when attaching this product, whether it is done manually or in a production solder reflow environment. Production quantities of this product are shipped in a standard tape and reel format. For packaging details, refer to the Skyworks Application Note, *Tape and Reel*, document number 101568.

Electrostatic Discharge (ESD) Sensitivity

The SKY65004 is a static-sensitive electronic device. Do not operate or store near strong electrostatic fields. Take proper ESD precautions.

Table 1. SKY65004 Signal Descriptions

Pin #	Name	Description
1	RF_IN	RF input
2	GND	Ground
3	RF_OUT	RF output
4	GND	Ground

Table 2. SKY65004 Absolute Maximum Ratings (T_A = +25 °C, unless otherwise noted)

Parameter	Symbol	Min	Typical	Max	Units
Supply voltage	VCC			6	V
RF output power	P _{OUT}			27	dBm
Supply current	I _{CC}			160	mA
Power dissipation	P _D			1.2	W
Operating case temperature	T _C	-40		+85	°C
Storage temperature	T _{ST}	-55		+125	°C
Junction temperature	T _J			150	°C

Note: Exposure to maximum rating conditions for extended periods may reduce device reliability. There is no damage to device with only one parameter set at the limit and all other parameters set at or below their nominal values.

Table 3. SKY65004 Recommended Operating Conditions

Parameter	Symbol	Min	Typical	Max	Units
Supply voltage	VCC		5		V
Frequency range	F	250		2700	MHz
Junction temperature	T _J			+140	°C

Table 4. SKY65004 Electrical Characteristics
(VCC = 5 V, Tc = 25 °C, unless otherwise noted)

Parameter	Symbol	Test Conditions	Min	Typical	Max	Units
Test Frequency = 450 MHz (Using the Test Circuit Shown in Figure 16)						
Small signal gain	G	CW		27		dB
Output power @ 1 dB compression	P1dB	CW		24		dBm
Output 3rd Order Intercept Point	OIP3	Two tones, each @ +7 dBm output power		42		dBm
Test Frequency = 900 MHz (Using the Test Circuit Shown in Figure 17)						
Small signal gain	G	CW		22		dB
Output power @ 1 dB compression	P1dB	CW		24		dBm
Output 3rd Order Intercept Point	OIP3	Two tones, each @ +7 dBm output power		42		dBm
Noise Figure	NF			4.0		dB
Output power @ ACPR = -45 dBc, 750 kHz offset	P _{OUT}	IS-95. Nine forward channels		18		dBm
Test Frequency = 1960 MHz (Using the Test Circuit Shown in Figure 18)						
Small signal gain	G	CW	14.0	15.5		dB
Output power @ 1 dB compression	P1dB	CW	23	25		dBm
Output 3rd Order Intercept Point	OIP3	Two tones, each @ +7 dBm output power		42		dBm
Noise Figure	NF			5.5		dB
Power Added Efficiency	PAE	CW, P _{OUT} = +25 dBm	42	48		%
Supply current	I _s			125	135	mA
Output power @ ACPR = -45 dBc, 885 kHz offset	P _{OUT}	IS-95. Nine forward channels		19		dBm
Test Frequency = 2140 MHz (Using the Test Circuit Shown in Figure 19)						
Small signal gain	G	CW		15		dB
Output power @ 1 dB compression	P1dB	CW		25		dBm
Output 3rd Order Intercept Point	OIP3	Two tones, each @ +7 dBm output power		42		dBm
Output power @ ACLR = -45 dBc, 5 MHz offset	P _{OUT}	WCDMA. Test model #1; 64 DPCH		17		dBm
Test Frequency = 2450 MHz (Using the Test Circuit Shown in Figure 20)						
Small signal gain	G	CW		14.5		dB
Output power @ 1 dB compression	P1dB	CW		25		dBm
Output 3rd Order Intercept Point	OIP3	Two tones, each @ +7 dBm output power		42		dBm
Noise Figure	NF			5.0		dB
Power Added Efficiency	PAE	CW, P _{OUT} = +26 dBm		50		%
Test Frequency = 2600 MHz (Using the Test Circuit Shown in Figure 22)						
Small signal gain	G	CW		14		dB
Output power @ 1 dB compression	P1dB	CW		25		dBm
Output 3rd Order Intercept Point	OIP3	Two tones, each @ +7 dBm output power		41		dBm

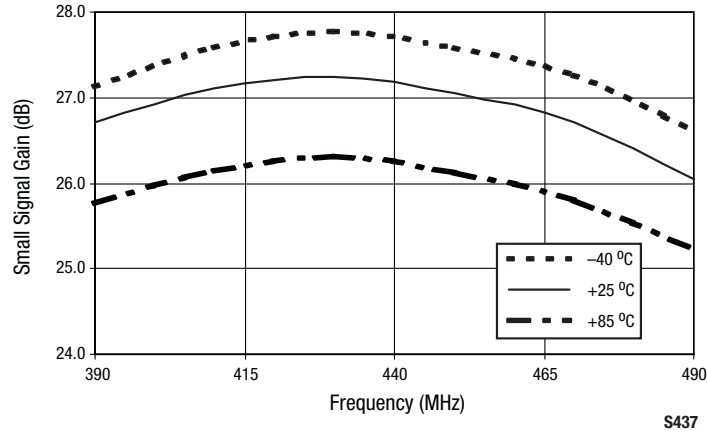

Figure 3. Typical Small Signal Gain From 390 to 490 MHz Over Temperature

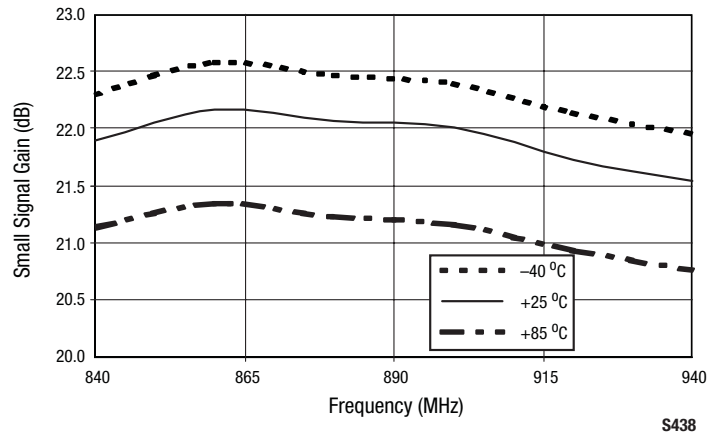

Figure 4. Typical Small Signal Gain From 840 to 940 MHz Over Temperature

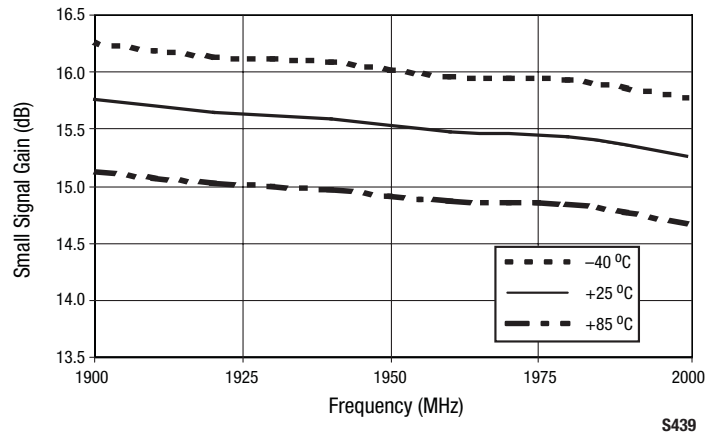

Figure 5. Typical Small Signal Gain From 1900 to 2000 MHz Over Temperature

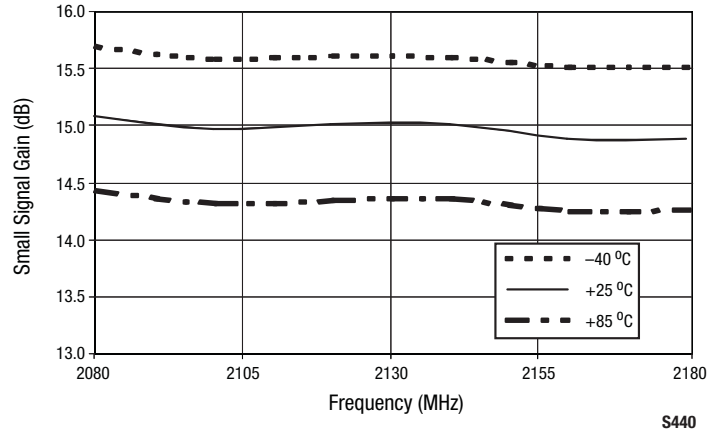

Figure 6. Typical Small Signal Gain From 2080 to 2180 MHz Over Temperature

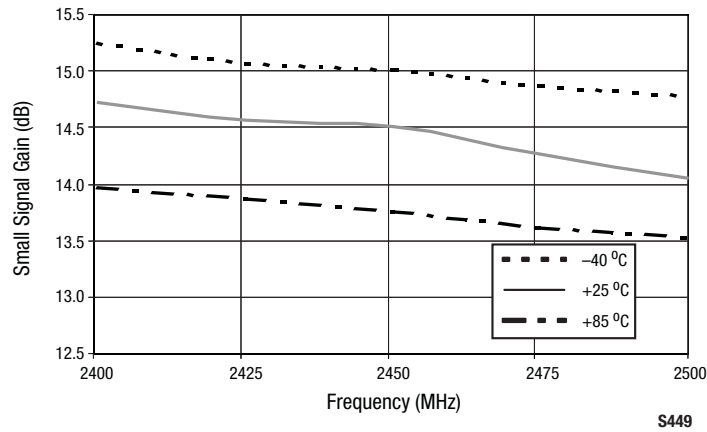

Figure 7. Typical Small Signal Gain From 2400 to 2500 MHz Over Temperature

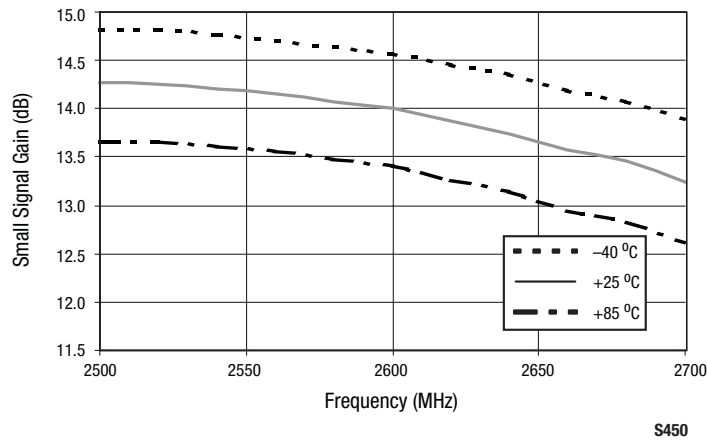

Figure 8. Typical Small Signal Gain From 2500 to 2700 MHz Over Temperature

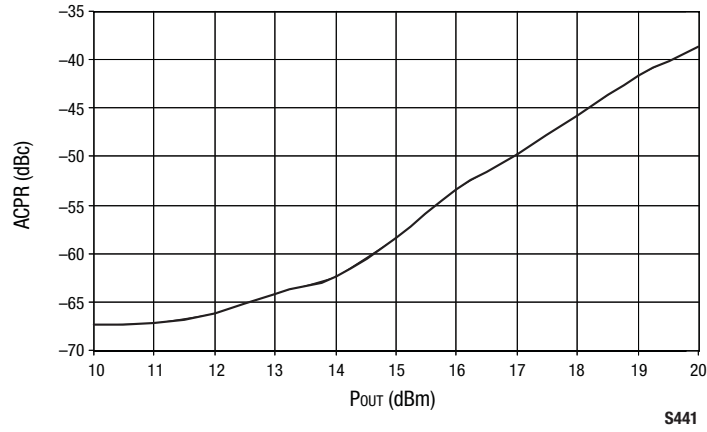

Figure 9. Typical ACPR vs P_{out} @ 900 MHz, 750 kHz Offset, and 25 °C

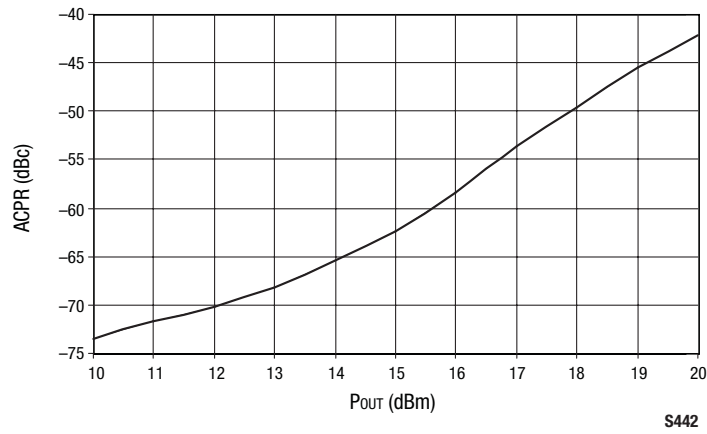

Figure 10. Typical ACPR vs P_{out} @ 1960 MHz, 885 kHz Offset, and 25 °C

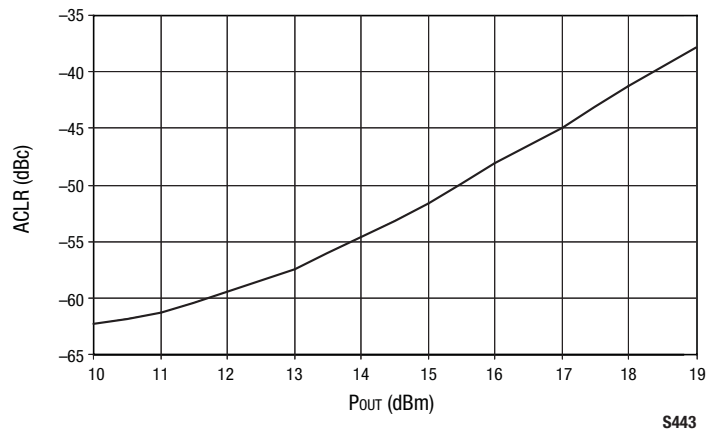

Figure 11. Typical ACLR vs P_{out} @ 2140 MHz, 5 MHz Offset, and 25 °C

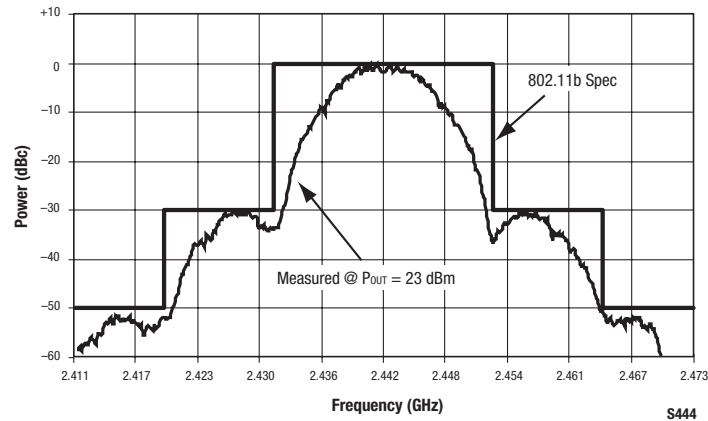

Figure 12. Spectral Response With 802.11b Signal (CCK, 11 Mbps)
(VCC = 3.3 V, Test Circuit Shown in Figure 21)

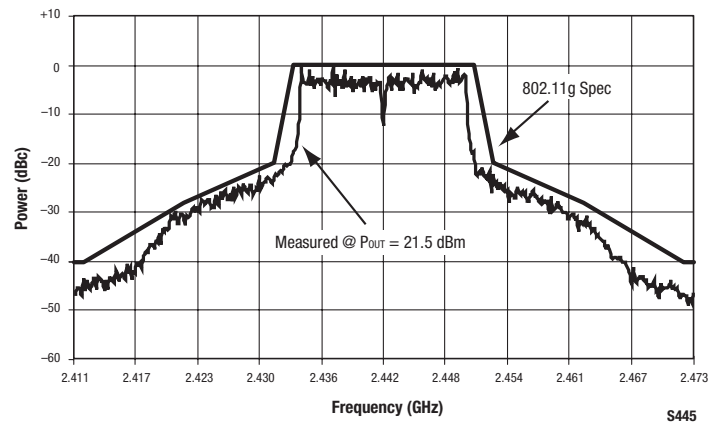

Figure 13. Spectral Response With 802.11g Signal (64-QAM, 54 Mbps)
(VCC = 3.3 V, Test Circuit Shown in Figure 21)

Evaluation Board Description

The Skyworks SKY65004 Evaluation Board is used to test the performance of the SKY65004 power amplifier driver. An assembly drawing for the Evaluation Board is shown in Figure 14 and the layer detail is provided in Figure 15.

Circuit Design Configurations

The following design considerations are general in nature and must be followed regardless of final use or configuration.

1. Paths to ground should be made as short as possible.
2. The ground pad of the SKY65004 power amplifier has special electrical and thermal grounding requirements. This pad is the main thermal conduit for heat dissipation. Since the circuit board acts as the heat sink, it must shunt as much heat as possible from the amplifier. As such, design the connection to the ground pad to dissipate the maximum wattage produced

to the circuit board. Multiple vias to the grounding layer are required.

NOTE: Junction temperature (T_j) of the device increases with a poor connection to the slug and ground. This reduces the lifetime of the device.

Suggested matching circuits are shown in Figures 16 through 22.

Testing Procedure

Use the following procedure to set up the SKY65004 Evaluation Board for testing:

1. Connect a 5.0 V supply to VCC. If available, enable the current limiting function of the power supply to 240 mA.
2. Connect a signal generator to the RF signal input port. Set it to the desired RF frequency at a power level of -15 dBm or less to the Evaluation Board but do NOT enable the RF signal.

3. Connect a spectrum analyzer to the RF signal output port.
4. Enable the power supply.
5. Enable the RF signal.
6. Take measurements.

CAUTION: *If any of the output signals exceed the rated maximum values, the SKY65004 Evaluation Board can be permanently damaged.*

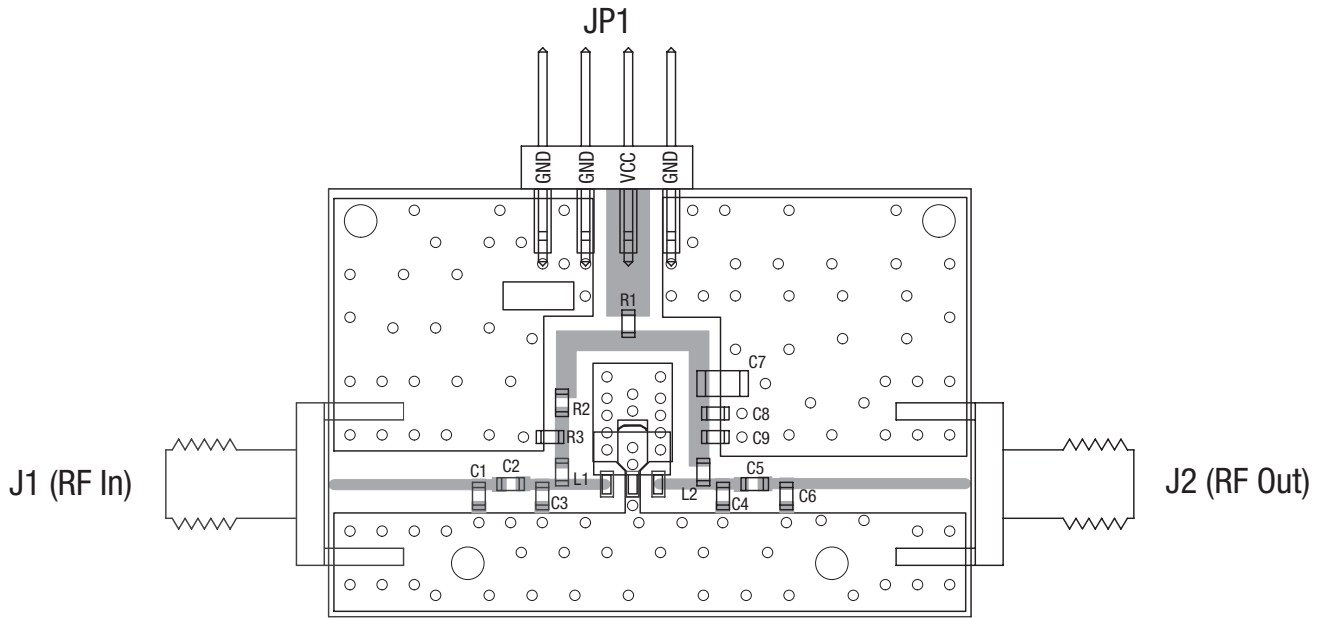

S446

Figure 14. Evaluation Board Assembly Drawing

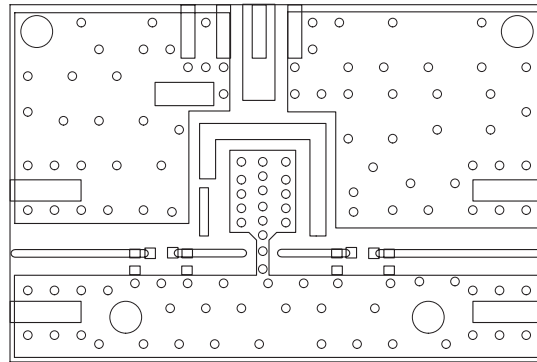

Layer 1: Top - Metal

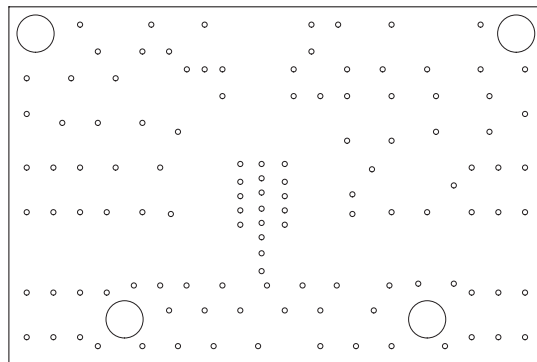

Layer 2: Ground

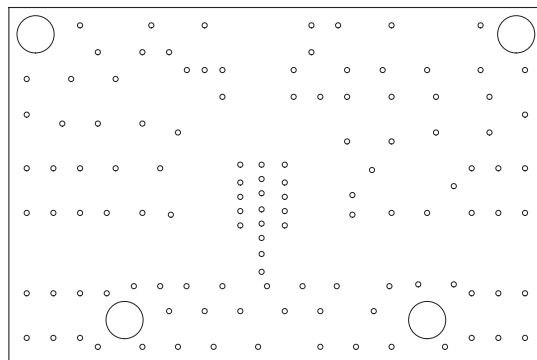

Layer 3: Ground

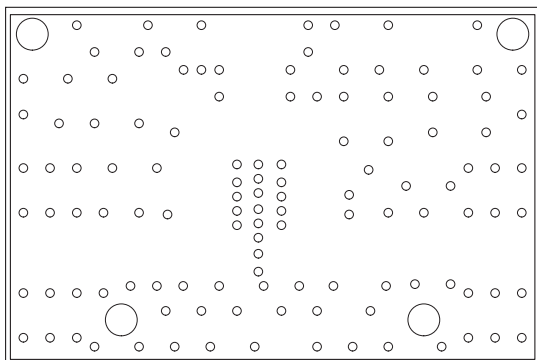

Layer 4: Solid Ground Plane

S447

Figure 15. Evaluation Board Layer Detail

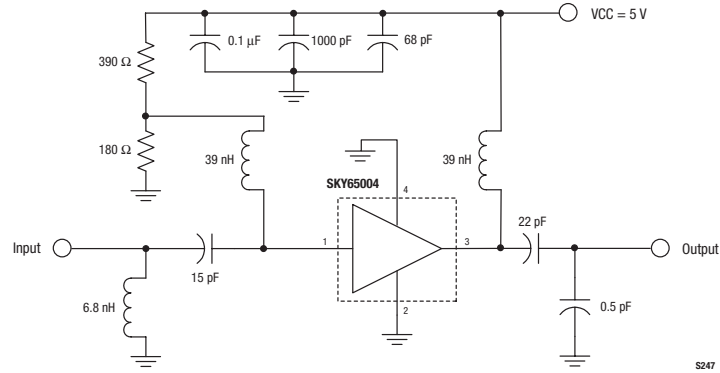

**Figure 16. Matching Circuit for 450 MHz
(Evaluation Kit #TW11-D634)**

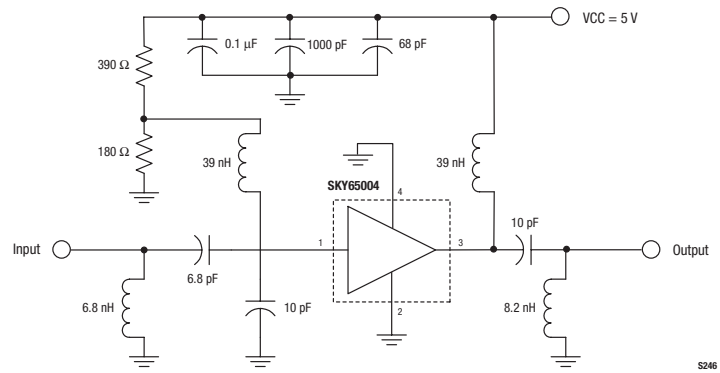

**Figure 17. Matching Circuit for 900 MHz
(Evaluation Kit #TW11-D631)**

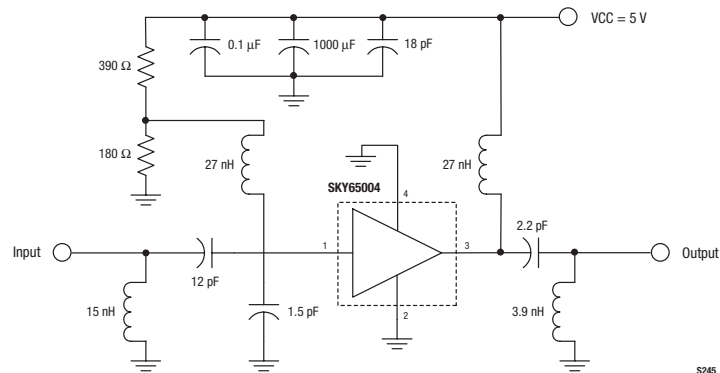

**Figure 18. Matching Circuit for 1960 MHz
(Evaluation Kit #TW11-D632)**

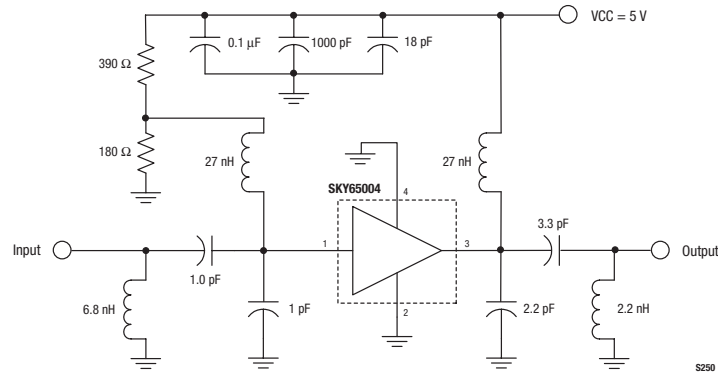

**Figure 19. Matching Circuit for 2140 MHz
(Evaluation Kit #TW11-D633)**

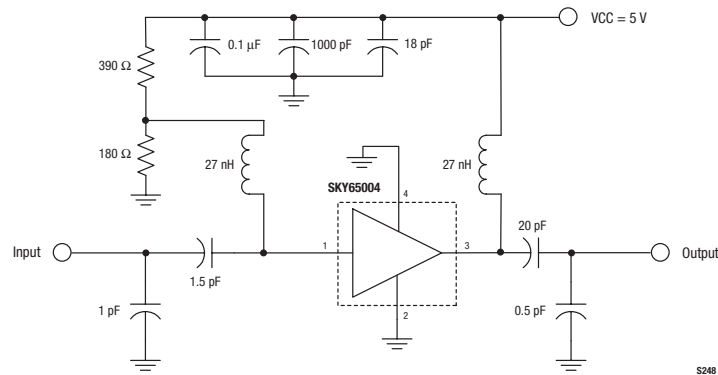

**Figure 20. Matching Circuit for 2450 MHz (VCC = 5 V)
(Evaluation Kit #TW11-D636)**

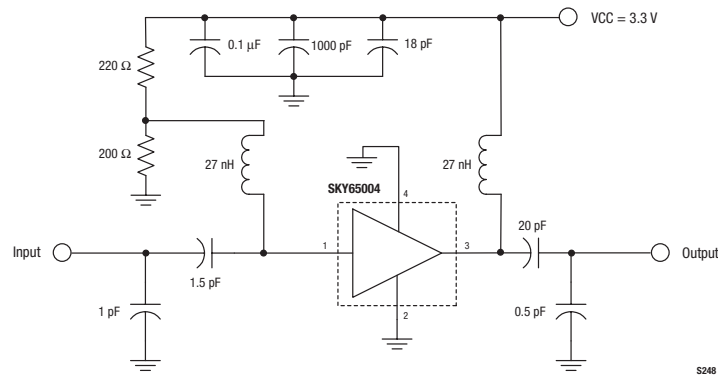

**Figure 21. Matching Circuit for 2450 MHz (VCC = 3.3 V)
(Evaluation Kit #TW11-D638)**

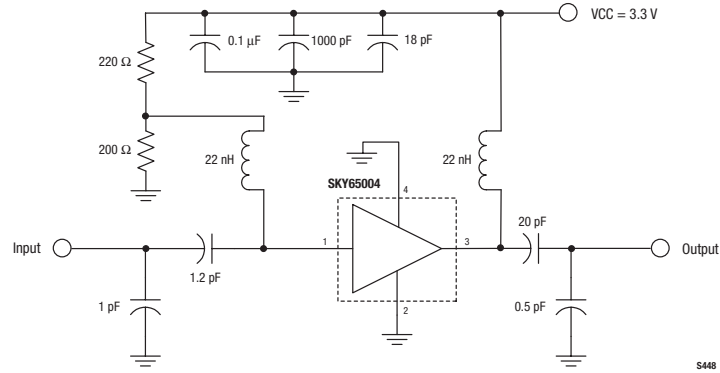

**Figure 22. Matching Circuit for 2600 MHz (VCC = 5.0 V)
(Evaluation Kit #TW11-D637)**

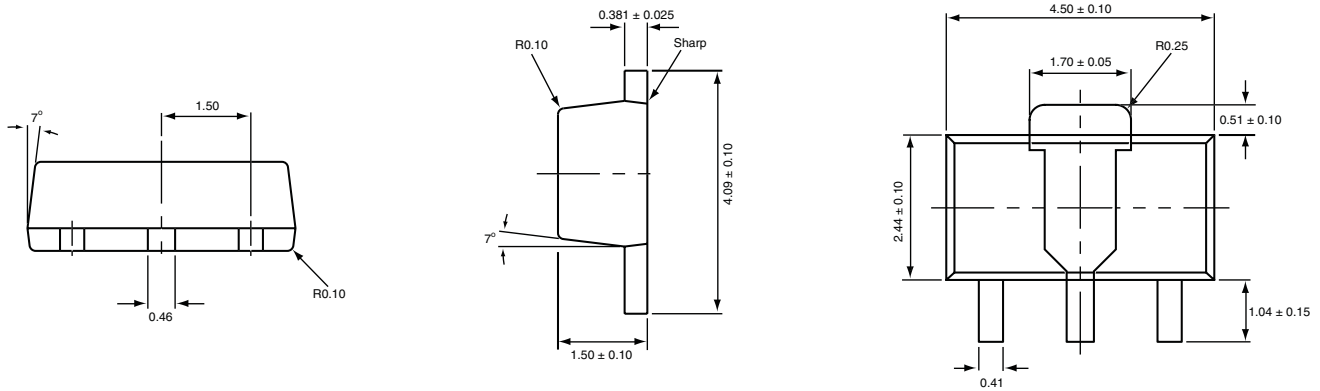

All measurements are in millimeters

S253

Figure 23. SKY65004 4-Pin SOT-89 Package Dimensions

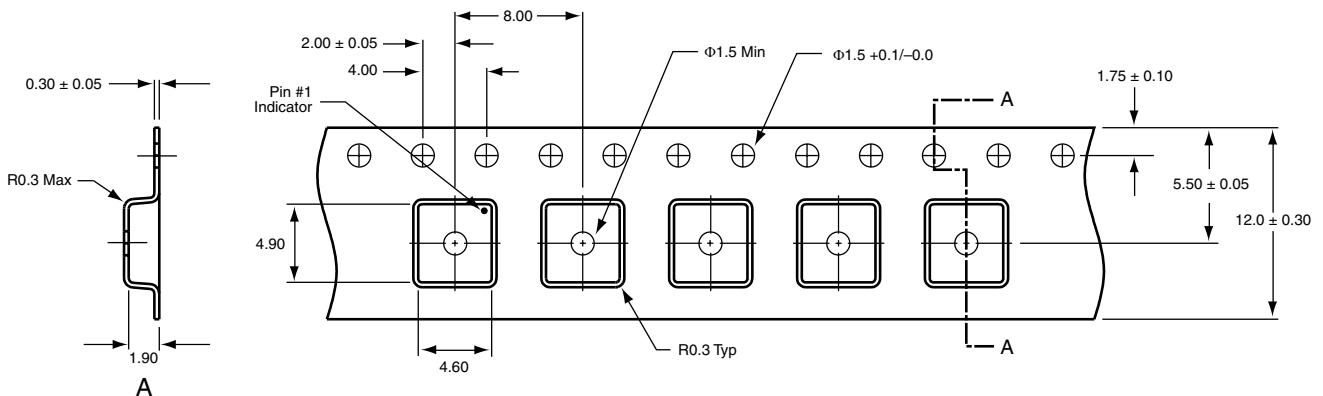

Notes:

1. Carrier tape material: black conductive polycarbonate or polystyrene
2. Cover tape material: transparent conductive PSA
3. Cover tape size: 9.3 mm width
4. All measurements are in millimeters

S264

Figure 24. SKY65004 4-Pin SOT-89 Tape and Reel Dimensions

Ordering Information

Model Name	Ordering Part Number	Evaluation Kit Part Number
SKY65004 250-2700 MHz Linear Power Amplifier Driver	SKY65004-11	TW11-D631 (900 MHz) TW11-D632 (1960 MHz) TW11-D633 (2140 MHz) TW11-D634 (450 MHz) TW11-D636 (2450 MHz, VCC = 5 V) TW11-D638 (2450 MHz, VCC = 3.3 V) TW11-D637 (2600 MHz)

Copyright © 2003, 2004 Skyworks Solutions, Inc. All Rights Reserved.

Information in this document is provided in connection with Skyworks Solutions, Inc. ("Skyworks") products. These materials are provided by Skyworks as a service to its customers and may be used for informational purposes only by the customer. Skyworks assumes no responsibility for errors or omissions in these materials. Skyworks may make changes to its documentation, products, specifications and product descriptions at any time, without notice. Skyworks makes no commitment to update the information and shall have no responsibility whatsoever for conflicts, incompatibilities, or other difficulties arising from future changes to its documentation, products, specifications and product descriptions.

No license, express or implied, by estoppel or otherwise, to any intellectual property rights is granted by or under this document. Except as may be provided in Skyworks Terms and Conditions of Sale for such products, Skyworks assumes no liability whatsoever in association with its documentation, products, specifications and product descriptions.

THESE MATERIALS ARE PROVIDED "AS IS" WITHOUT WARRANTY OF ANY KIND, EITHER EXPRESS OR IMPLIED OR OTHERWISE, RELATING TO SALE AND/OR USE OF SKYWORKS PRODUCTS INCLUDING WARRANTIES RELATING TO FITNESS FOR A PARTICULAR PURPOSE, MERCHANTABILITY, PERFORMANCE, QUALITY OR NON-INFRINGEMENT OF ANY PATENT, COPYRIGHT OR OTHER INTELLECTUAL PROPERTY RIGHT. SKYWORKS FURTHER DOES NOT WARRANT THE ACCURACY OR COMPLETENESS OF THE INFORMATION, TEXT, GRAPHICS OR OTHER ITEMS CONTAINED WITHIN THESE MATERIALS. SKYWORKS SHALL NOT BE LIABLE FOR ANY DAMAGES, INCLUDING SPECIAL, INDIRECT, INCIDENTAL, OR CONSEQUENTIAL DAMAGES, INCLUDING WITHOUT LIMITATION, LOST REVENUES OR LOST PROFITS THAT MAY RESULT FROM THE USE OF THESE MATERIALS WHETHER OR NOT THE RECIPIENT OF MATERIALS HAS BEEN ADVISED OF THE POSSIBILITY OF SUCH DAMAGE.

Skyworks products are not intended for use in medical, lifesaving or life-sustaining applications. Skyworks customers using or selling Skyworks products for use in such applications do so at their own risk and agree to fully indemnify Skyworks for any damages resulting from such improper use or sale.

The following are trademarks of Skyworks Solutions, Inc.: Skyworks™, the Skyworks logo, and Breakthrough Simplicity™. Product names or services listed in this publication are for identification purposes only, and may be trademarks of Skyworks or other third parties. Third-party brands and names are the property of their respective owners. Additional information, posted at www.skyworksinc.com, is incorporated by reference.