

NL27WZ04

Dual Inverter

The NL27WZ04 is a high performance dual inverter operating from a 1.65 V to 5.5 V supply. High impedance TTL compatible inputs significantly reduce current loading to input drivers while TTL compatible outputs offer improved switching noise performance.

Features

- Extremely High Speed: t_{PD} 2.0 ns (typical) at $V_{CC} = 5$ V
- Designed for 1.65 V to 5.5 V V_{CC} Operation
- Over Voltage Tolerant Inputs and Outputs
- LVTTL Compatible – Interface Capability with 5 V TTL Logic with $V_{CC} = 3$ V
- LVCMOS Compatible
- 24 mA Balanced Output Sink and Source Capability
- Near Zero Static Supply Current Substantially Reduces System Power Requirements
- Replacement for NC7W04
- Chip Complexity: FET = 72; Equivalent Gate = 18
- Pb-Free Packages are Available

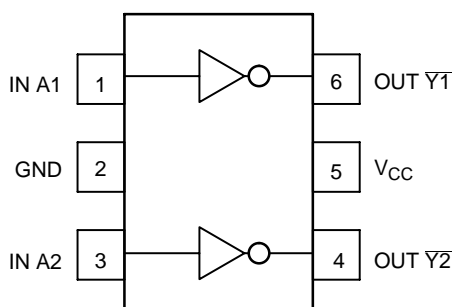

Figure 1. Pinout (Top View)

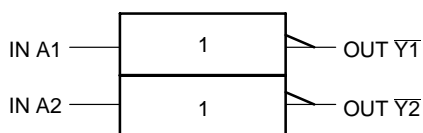

Figure 2. Logic Symbol



ON Semiconductor®

<http://onsemi.com>

MARKING DIAGRAMS

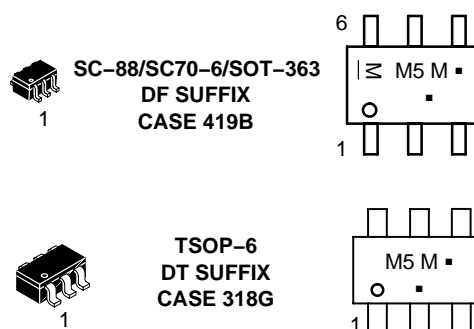

M5 = Device Code
M = Date Code*
▪ = Pb-Free Package

(Note: Microdot may be in either location)

*Date Code orientation and/or position and underbar may vary depending upon manufacturing location.

PIN ASSIGNMENT

1	IN A1
2	GND
3	IN A2
4	OUT $\bar{Y}2$
5	V_{CC}
6	OUT $\bar{Y}1$

FUNCTION TABLE

A Input	\bar{Y} Output
L	H
H	L

ORDERING INFORMATION

See detailed ordering and shipping information in the package dimensions section on page 4 of this data sheet.

NL27WZ04

MAXIMUM RATINGS

Characteristics	Symbol	Value	Unit
DC Supply Voltage	V_{CC}	-0.5 to +7.0	V
DC Input Voltage	V_I	$-0.5 \leq V_I \leq +7.0$	V
DC Output Voltage	Output in HIGH or LOW State (Note 1) V_O	$-0.5 \leq V_O \leq 7.0$	V
DC Input Diode Current	$V_I < \text{GND}$ I_{IK}	-50	mA
DC Output Diode Current	$V_O < \text{GND}$ I_{OK}	-50	mA
DC Output Source/Sink Current	I_O	± 50	mA
DC Supply Current Per Supply Pin	I_{CC}	± 100	mA
DC Ground Current Per Ground Pin	I_{GND}	± 100	mA
Storage Temperature Range	T_{STG}	-65 to +150	°C
Power Dissipation in Still Air	SC-88, TSOP-6 (Note 2) P_D	200	mW
Thermal Resistance	SC-88, TSOP-6 (Note 2) θ_{JA}	333	°C/W
Lead temperature, 1 mm from Case for 10 Seconds	T_L	260	°C
Junction Temperature Under Bias	T_J	+150	°C
ESD Withstand Voltage	Human Body Model (Note 3) Machine Model (Note 4) Charged Device Model (Note 5) V_{ESD}	> 2000 > 200 N/A	V

Stresses exceeding Maximum Ratings may damage the device. Maximum Ratings are stress ratings only. Functional operation above the Recommended Operating Conditions is not implied. Extended exposure to stresses above the Recommended Operating Conditions may affect device reliability.

1. I_O absolute maximum rating must be observed.
2. Measured with minimum pad spacing on an FR4 board, using 10 mm-by-1 inch, 2-ounce copper trace with no air flow.
3. Tested to EIA/JESD22-A114-A
4. Tested to EIA/JESD22-A115-A
5. Tested to JESD22-C101-A

RECOMMENDED OPERATING CONDITIONS

Parameter	Symbol	Min	Max	Unit
Supply Voltage	Operating Data Retention Only V_{CC}	1.65 1.5	5.5 5.5	V
Input Voltage	V_I	0	5.5	V
Output Voltage	(HIGH or LOW State) V_O	0	5.5	V
Operating Free-Air Temperature	T_A	-40	+85	°C
Input Transition Rise or Fall Rate	$\Delta t/\Delta V$	0	20	ns/V
	$V_{CC} = 2.5 \text{ V} \pm 0.2 \text{ V}$	0	10	
	$V_{CC} = 3.0 \text{ V} \pm 0.3 \text{ V}$	0	5	
	$V_{CC} = 5.0 \text{ V} \pm 0.5 \text{ V}$	0		

NL27WZ04

DC ELECTRICAL CHARACTERISTICS

Parameter	Condition	Symbol	V _{CC} (V)	T _A = 25°C			-40°C ≤ T _A ≤ 85°C		Unit
				Min	Typ	Max	Min	Max	
High-Level Input Voltage		V _{IH}	1.65–1.95	0.75 V _{CC}			0.75 V _{CC}		V
			2.3 to 5.5	0.7 V _{CC}			0.7 V _{CC}		
Low-Level Input Voltage		V _{IL}	1.65–1.95			0.25 V _{CC}		0.25 V _{CC}	V
			2.3 to 5.5			0.3 V _{CC}		0.3 V _{CC}	
High-Level Output Voltage V _{IN} = V _{IL}	I _{OH} = -100 μA	V _{OH}	1.65 to 5.5	V _{CC} - 0.1	V _{CC}		V _{CC} - 0.1		V
	I _{OH} = -3 mA		1.65	1.29	1.52		1.29		
	I _{OH} = -8 mA		2.3	1.9	2.1		1.9		
	I _{OH} = -12 mA		2.7	2.2	2.4		2.2		
	I _{OH} = -16 mA		3.0	2.4	2.7		2.4		
	I _{OH} = -24 mA		3.0	2.3	2.5		2.3		
	I _{OH} = -32 mA		4.5	3.8	4.0		3.8		
Low-Level Output Voltage V _{IN} = V _{IH}	I _{OL} = 100 μA	V _{OL}	1.65 to 5.5			0.1		0.1	V
	I _{OL} = 3 mA		1.65		0.08	0.24		0.24	
	I _{OL} = 8 mA		2.3		0.20	0.3		0.3	
	I _{OL} = 12 mA		2.7		0.22	0.4		0.4	
	I _{OL} = 16 mA		3.0		0.28	0.4		0.4	
	I _{OL} = 24 mA		3.0		0.38	0.55		0.55	
	I _{OL} = 32 mA		4.5		0.42	0.55		0.55	
Input Leakage Current	V _{IN} = V _{CC} or GND	I _{IN}	0 to 5.5			±0.1		±1.0	μA
Power Off-Output Leakage Current	V _{OUT} = 5.5 V	I _{OFF}	0			1		10	μA
Quiescent Supply Current	V _{IN} = V _{CC} or GND	I _{CC}	1.65 to 5.5			1		10	μA

AC ELECTRICAL CHARACTERISTICS t_R = t_F = 2.5 ns; C_L = 50 pF; R_L = 500 Ω

Parameter	Condition	Symbol	V _{CC} (V)	T _A = 25°C			-40°C ≤ T _A ≤ 85°C		Unit
				Min	Typ	Max	Min	Max	
Propagation Delay (Figure 3 and 4)	R _L = 1 MΩ, C _L = 15 pF	t _{PLH} t _{PHL}	1.65	1.8	2.3	9.2	1.8	11.0	ns
	R _L = 1 MΩ, C _L = 15 pF		1.8	1.8	4.4	7.6	1.8	8.4	
	R _L = 1 MΩ, C _L = 15 pF		2.5 ± 0.2	1.2	3.0	5.1	1.2	5.6	
	R _L = 1 MΩ, C _L = 15 pF		3.3 ± 0.3	0.8	2.2	3.4	0.8	3.8	
	R _L = 500 Ω, C _L = 50 pF			1.2	2.9	4.5	1.2	5.0	
	R _L = 1 MΩ, C _L = 15 pF		5.0 ± 0.5	0.5	1.8	2.8	0.5	3.1	
	R _L = 500 Ω, C _L = 50 pF			0.8	2.3	3.6	0.8	4.0	

CAPACITIVE CHARACTERISTICS

Parameter	Symbol	Condition	Typical	Unit
Input Capacitance	C _{IN}	V _{CC} = 5.5 V, V _I = 0 V or V _{CC}	2.5	pF
Power Dissipation Capacitance (Note 6)	C _{PD}	10 MHz, V _{CC} = 3.3 V, V _I = 0 V or V _{CC}	9	pF
		10 MHz, V _{CC} = 5.5 V, V _I = 0 V or V _{CC}	11	

6. C_{PD} is defined as the value of the internal equivalent capacitance which is calculated from the operating current consumption without load. Average operating current can be obtained by the equation: I_{CC(OPR)} = C_{PD} • V_{CC} • f_{in} + I_{CC}. C_{PD} is used to determine the no-load dynamic power consumption; P_D = C_{PD} • V_{CC}² • f_{in} + I_{CC} • V_{CC}.

NL27WZ04

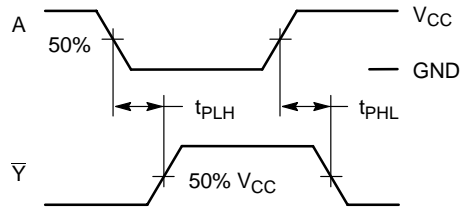

PROPAGATION DELAYS

$t_R = t_F = 2.5$ ns, 10% to 90%; $f = 1$ MHz; $t_W = 500$ ns

Figure 3. Switching Waveforms

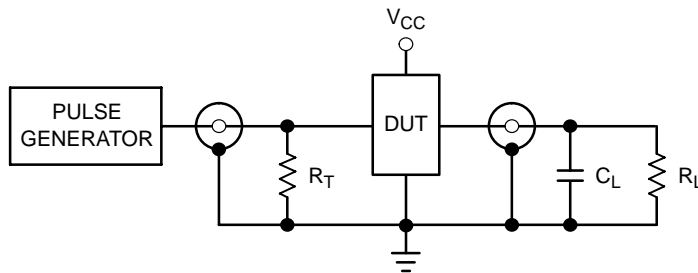

$R_T = Z_{OUT}$ of pulse generator (typically 50Ω)

Figure 4. Test Circuit

ORDERING INFORMATION

Device	Package	Shipping†
NL27WZ04DFT2	SC-88/SC70-6/SOT-363	3000 / Tape & Reel
NL27WZ04DFT2G	SC-88/SC70-6/SOT-363 (Pb-Free)	
NL27WZ04DTT1	TSOP-6	
NL27WZ04DTT1G	TSOP-6 (Pb-Free)	

†For information on tape and reel specifications, including part orientation and tape sizes, please refer to our Tape and Reel Packaging Specifications Brochure, BRD8011/D.

NL27WZ04

PACKAGE DIMENSIONS

SC-88/SC70-6/SOT-363
CASE 419B-02
ISSUE W

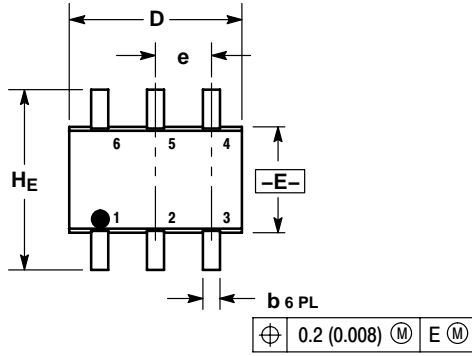

NOTES:

1. DIMENSIONING AND TOLERANCING PER ANSI Y14.5M, 1982.
2. CONTROLLING DIMENSION: INCH.
3. 419B-01 OBSOLETE, NEW STANDARD 419B-02.

DIM	MILLIMETERS			INCHES		
	MIN	NOM	MAX	MIN	NOM	MAX
A	0.80	0.95	1.10	0.031	0.037	0.043
A1	0.00	0.05	0.10	0.000	0.002	0.004
A3	0.20 REF			0.008 REF		
b	0.10	0.21	0.30	0.004	0.008	0.012
C	0.10	0.14	0.25	0.004	0.005	0.010
D	1.80	2.00	2.20	0.070	0.078	0.086
E	1.15	1.25	1.35	0.045	0.049	0.053
e	0.65 BSC			0.026 BSC		
L	0.10	0.20	0.30	0.004	0.008	0.012
HE	2.00	2.10	2.20	0.078	0.082	0.086

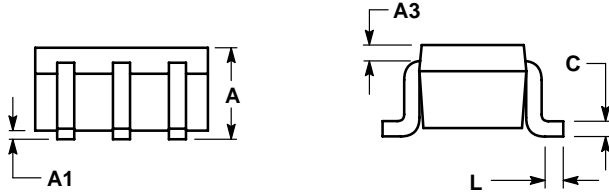

SOLDERING FOOTPRINT*

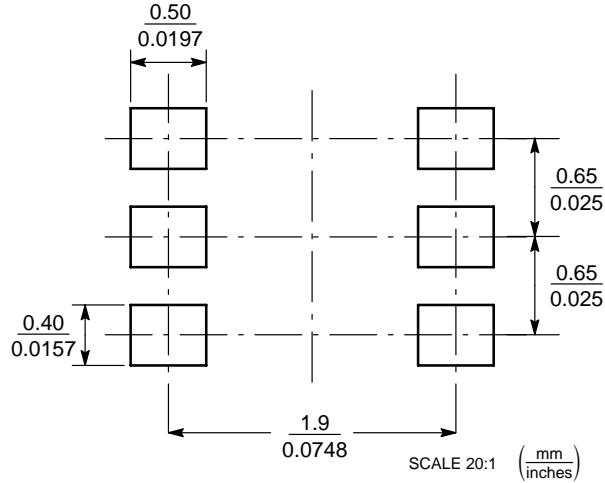

*For additional information on our Pb-Free strategy and soldering details, please download the ON Semiconductor Soldering and Mounting Techniques Reference Manual, SOLDERRM/D.

NL27WZ04

PACKAGE DIMENSIONS

TSOP-6
CASE 318G-02
ISSUE S

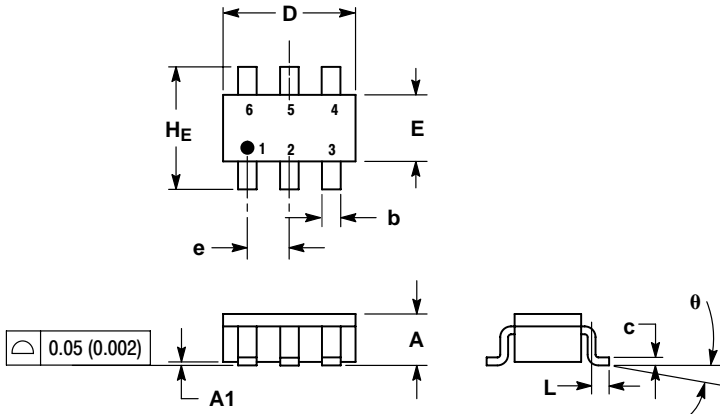

NOTES:

1. DIMENSIONING AND TOLERANCING PER ANSI Y14.5M, 1982.
2. CONTROLLING DIMENSION: MILLIMETER.
3. MAXIMUM LEAD THICKNESS INCLUDES LEAD FINISH THICKNESS. MINIMUM LEAD THICKNESS IS THE MINIMUM THICKNESS OF BASE MATERIAL.
4. DIMENSIONS A AND B DO NOT INCLUDE MOLD FLASH, PROTRUSIONS, OR GATE BURRS.

DIM	MILLIMETERS			INCHES		
	MIN	NOM	MAX	MIN	NOM	MAX
A	0.90	1.00	1.10	0.035	0.039	0.043
A1	0.01	0.06	0.10	0.001	0.002	0.004
b	0.25	0.38	0.50	0.010	0.014	0.020
c	0.10	0.18	0.26	0.004	0.007	0.010
D	2.90	3.00	3.10	0.114	0.118	0.122
E	1.30	1.50	1.70	0.051	0.059	0.067
e	0.85	0.95	1.05	0.034	0.037	0.041
L	0.20	0.40	0.60	0.008	0.016	0.024
HE	2.50	2.75	3.00	0.099	0.108	0.118
θ	0°	-	10°	0°	-	10°

SOLDERING FOOTPRINT*

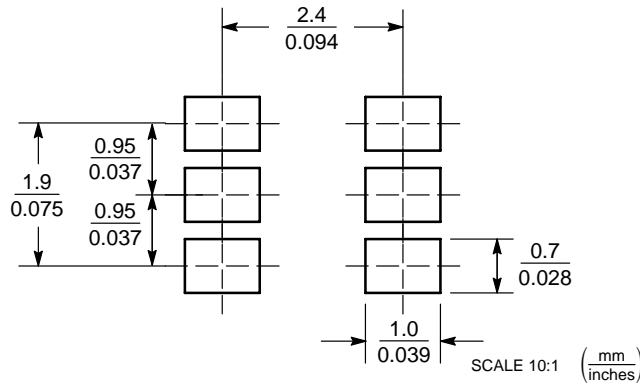

*For additional information on our Pb-Free strategy and soldering details, please download the ON Semiconductor Soldering and Mounting Techniques Reference Manual, SOLDERRM/D.

ON Semiconductor and are registered trademarks of Semiconductor Components Industries, LLC (SCILLC). SCILLC reserves the right to make changes without further notice to any products herein. SCILLC makes no warranty, representation or guarantee regarding the suitability of its products for any particular purpose, nor does SCILLC assume any liability arising out of the application or use of any product or circuit, and specifically disclaims any and all liability, including without limitation special, consequential or incidental damages. "Typical" parameters which may be provided in SCILLC data sheets and/or specifications can and do vary in different applications and actual performance may vary over time. All operating parameters, including "Typicals" must be validated for each customer application by customer's technical experts. SCILLC does not convey any license under its patent rights nor the rights of others. SCILLC products are not designed, intended, or authorized for use as components in systems intended for surgical implant into the body, or other applications intended to support or sustain life, or for any other application in which the failure of the SCILLC product could create a situation where personal injury or death may occur. Should Buyer purchase or use SCILLC products for any such unintended or unauthorized application, Buyer shall indemnify and hold SCILLC and its officers, employees, subsidiaries, affiliates, and distributors harmless against all claims, costs, damages, and expenses, and reasonable attorney fees arising out of, directly or indirectly, any claim of personal injury or death associated with such unintended or unauthorized use, even if such claim alleges that SCILLC was negligent regarding the design or manufacture of the part. SCILLC is an Equal Opportunity/Affirmative Action Employer. This literature is subject to all applicable copyright laws and is not for resale in any manner.

PUBLICATION ORDERING INFORMATION

LITERATURE FULFILLMENT:
Literature Distribution Center for ON Semiconductor
P.O. Box 5163, Denver, Colorado 80217 USA
Phone: 303-675-2175 or 800-344-3860 Toll Free USA/Canada
Fax: 303-675-2176 or 800-344-3867 Toll Free USA/Canada
Email: orderlit@onsemi.com

N. American Technical Support: 800-282-9855 Toll Free USA/Canada
Europe, Middle East and Africa Technical Support:
Phone: 421 33 790 2910
Japan Customer Focus Center
Phone: 81-3-5773-3850

ON Semiconductor Website: www.onsemi.com
Order Literature: <http://www.onsemi.com/orderlit>
For additional information, please contact your local Sales Representative