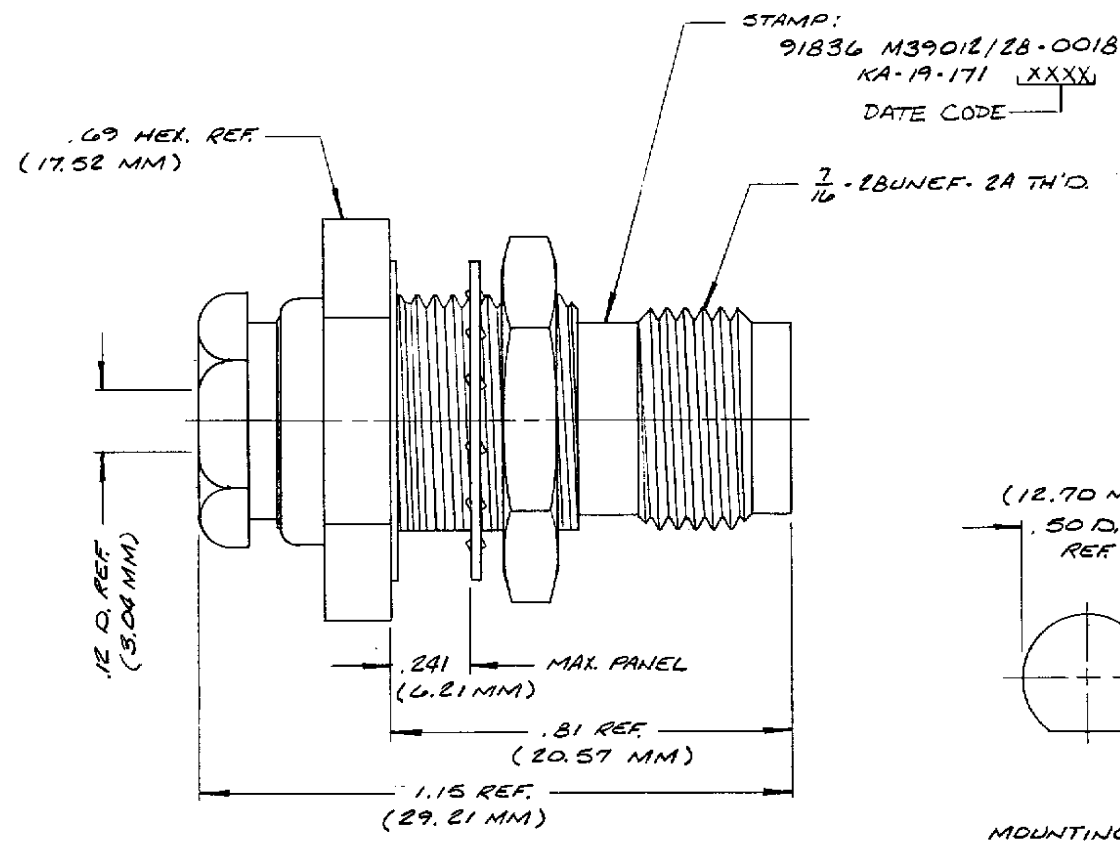

REVISIONS

ISSUE	CHANGES
1	CN 22767 E JEP 17 NOV 81
2	CN 32302 A LNM 20 JUN 90
3	CN 32955 A WJM 12 MAR 91

GSD

M39012/28-0018

NOTES:

- FOR USE WITH RG-174 & 316/U CABLES.
- FOR CABLING INSTRUCTIONS SEE CP-1050.
- MATERIALS:

CENTER CONTACT - BERYLLIUM COPPER, QQ-C-530.
 LOCKWASHER - PHOSPHOR BRONZE, QQ-B-750.
 ALL OTHER METAL PARTS - BRASS, QQ-B-626
 GASKETS - SILICONE RUBBER, ZZ-R-765.
 INSULATOR - TEFLON, L-P-403.

(NOTES CONT'D.)

- FINISHES:
 CENTER CONTACT - GOLD PLATE, MIL-G-45204B
 ALL OTHER METAL PARTS - SILVER PLATE, QQ-6-365.
- ELECTRICAL CHARACTERISTICS:
 NOMINAL IMPEDANCE - 50 Ω OHMS
 FREQUENCY RANGE - DC-11GHZ
 WORKING VOLTAGE - 500 RMS

UNLESS OTHERWISE SPECIFIED:

- TOLERANCES: FRACTIONS & 2 PLACE DECIMALS ± .010
 3 PLACE DECIMALS ± .004 ANGLES ± 0°30'
- REMOVE ALL BURRS, BREAK SHARP EDGES .005 MAX.
- NO FILLETS PERMITTED.
- SURFACE ROUGHNESS 63 MICROINCHES RMS MAX.
- ALL DIMENSIONS PRIOR TO PLATING.
- ALL PLATING IN ACCORDANCE WITH KER 10004.

SCALE:	4:1
APPROX. SURFACE AREA:	
	KA-19-171
USED ON:	
REF:	
	TNC BULKHEAD JACK

DRAWN	MCD	DATE	21 DEC 83
APPR.	MJB	DATE	22 DEC 83

KINGS
 ELECTRONICS CO., INC.
TELEPHONE, NEW YORK 10781
GSD

M39012/28-0018