



**GENERAL DESCRIPTION**



The ICS8602 is a high performance, low skew, 1-to-9 Differential-to-LVCMOS/LVTTL Zero Delay Buffer and a member of the HiPerClockS™ family of High Performance Clocks Solutions from ICS. The CLK, nCLK pair can accept most standard differential input levels. The VCO operates at a frequency range of 250MHz to 500MHz. The external feedback allows the device to achieve “zero delay” between the input clock and the output clocks. The device is designed only for 1:1 input/output frequency ratios. The output divider allows a wide input/output frequency range with the 250MHz to 500MHz VCO. The PLL\_SEL pin can be used to bypass the PLL for system test and debug purposes. In bypass mode, the reference clock is routed around the PLL and into the internal output dividers. The low impedance LVCMOS/LVTTL outputs are designed to drive 50Ω series or parallel terminated transmission lines. The effective fanout can be doubled by utilizing the ability of the outputs to drive two series terminated lines. The differential reference clock input will accept any differential signal levels.

**FEATURES**

- Fully integrated PLL
- 9 LVCMOS/LVTTL outputs, 7Ω typical output impedance
- CLK, nCLK pair can accept the following differential input levels: LVPECL, LVDS, LVHSTL, SSTL, HCSL
- Output frequency range: 15.625MHz to 250MHz
- Input frequency range: 15.625MHz to 250MHz
- VCO range: 250MHz to 500MHz
- External feedback for “zero delay” clock regeneration with configurable frequencies
- Cycle-to-cycle jitter: 36ps (typical)
- Output skew: 125ps (maximum)
- Static Phase Offset: TBD±100ps (typical)
- 3.3V supply voltage
- 0°C to 70°C ambient operating temperature

**BLOCK DIAGRAM**

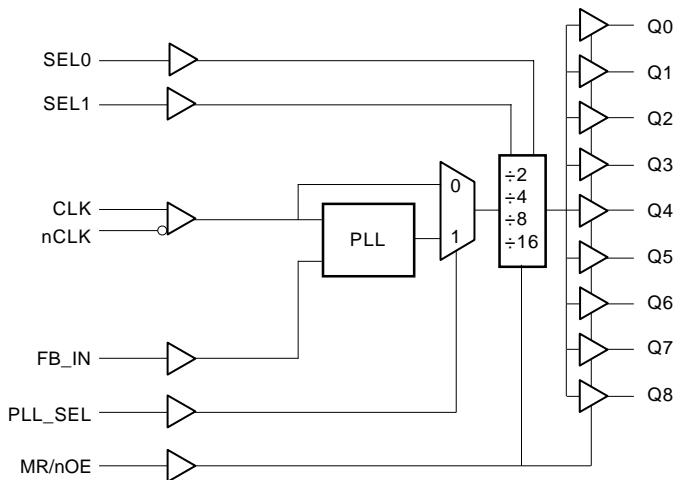

**PIN ASSIGNMENT**

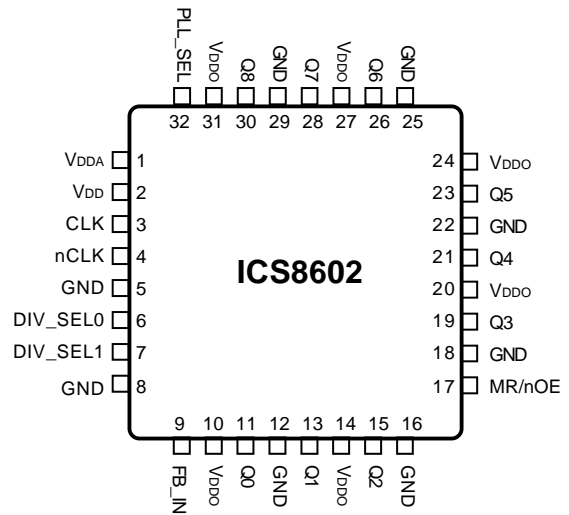

**32-Lead LQFP**  
7mm x 7mm x 1.4mm package body  
**Y Package**  
Top View

The Preliminary Information presented herein represents a product in prototyping or pre-production. The noted characteristics are based on initial product characterization. Integrated Circuit Systems, Incorporated (ICS) reserves the right to change any circuitry or specifications without notice.



**TABLE 1. PIN DESCRIPTIONS**

Number	Name	Type		Description
1	V <sub>DDA</sub>	Power		Analog supply pin.
2	V <sub>DD</sub>	Power		Core supply pin.
3	CLK	Input	Pulldown	Non-inverting differential clock input.
4	nCLK	Input	Pullup	Inverting differential clock input.
5, 8, 12, 16, 18, 22, 25, 29	GND	Power		Power supply ground.
6, 7	DIV_SEL0, DIV_SEL1	Input	Pulldown	Determines output divider valued in Table 3. LVCMOS / LVTTL interface levels.
9	FB_IN	Input	Pulldown	Feedback input to phase detector for regenerating clocks with "zero delay". LVCMOS / LVTTL interface levels.
10, 14, 20, 24, 27, 31	V <sub>DDO</sub>	Power		Output supply pins.
11, 13, 15, 19, 21, 23, 26, 28, 30	Q0, Q1, Q2, Q3, Q4, Q5, Q6, Q7, Q8	Output		Clock outputs. 7Ω typical output impedance. LVCMOS / LVTTL interface levels.
17	MR/nOE	Input	Pulldown	Active HIGH Master Reset. Active LOW output enable. When logic HIGH, the internal dividers are reset and the outputs are tri-stated (HiZ). When logic LOW, the internal dividers and the outputs are enabled. LVCMOS / LVTTL interface levels.
32	PLL_SEL	Input	Pullup	Selects between the PLL and the reference clock as the input to the dividers. When HIGH, selects PLL. When LOW, selects reference clock. LVCMOS / LVTTL interface levels.

NOTE: Pullup and Pulldown refer to internal input resistors. See Table 2, Pin Characteristics, for typical values.

**TABLE 2. PIN CHARACTERISTICS**

Symbol	Parameter	Test Conditions	Minimum	Typical	Maximum	Units
C <sub>IN</sub>	Input Capacitance				4	pF
R <sub>PULLUP</sub>	Input Pullup Resistor			51		KΩ
R <sub>PULLDOWN</sub>	Input Pulldown Resistor			51		KΩ
C <sub>PD</sub>	Power Dissipation Capacitance (per output)	V <sub>DD</sub> , V <sub>DDA</sub> , V <sub>DDO</sub> = 3.47V		TBD		pF
R <sub>OUT</sub>	Output Impedance			7		Ω

**TABLE 3A. CONTROL INPUT FUNCTION TABLE, PLL\_SEL = 1**

DIV_SEL1	DIV_SEL0	f <sub>OUT</sub> = f <sub>IN</sub> Frequency Range (MHz)	
		Minimum	Maximum
		0	0
0	1	62.5	125
1	0	31.25	62.5
1	1	15.625	31.25

**TABLE 3B. CONTROL INPUT FUNCTION TABLE, PLL\_SEL = 0  
PLL BYPASS MODE**

DIV_SEL1	DIV_SEL0	Frequency Divider	
		f <sub>IN</sub>	f <sub>OUT</sub>
0	0	f <sub>IN</sub>	f <sub>IN</sub> /2
0	1	f <sub>IN</sub>	f <sub>IN</sub> /4
1	0	f <sub>IN</sub>	f <sub>IN</sub> /8
1	1	f <sub>IN</sub>	f <sub>IN</sub> /16



**ABSOLUTE MAXIMUM RATINGS**

Supply Voltage, $V_{DD}$	4.6V
Inputs, $V_I$	-0.5V to $V_{DD} + 0.5V$
Outputs, $V_O$	-0.5V to $V_{DDO} + 0.5V$
Package Thermal Impedance, $\theta_{JA}$	42.1°C/W (0 lfpm)
Storage Temperature, $T_{STG}$	-65°C to 150°C

NOTE: Stresses beyond those listed under Absolute Maximum Ratings may cause permanent damage to the device. These ratings are stress specifications only. Functional operation of product at these conditions or any conditions beyond those listed in the *DC Characteristics* or *AC Characteristics* is not implied. Exposure to absolute maximum rating conditions for extended periods may affect product reliability.

www.DataSheet4U.com

**TABLE 4A. POWER SUPPLY DC CHARACTERISTICS,  $V_{DD} = V_{DDA} = V_{DDO} = 3.3V \pm 5\%$ ,  $T_A = 0^\circ C$  TO  $70^\circ C$**

Symbol	Parameter	Test Conditions	Minimum	Typical	Maximum	Units
$V_{DD}$	Core Supply Voltage		3.135	3.3	3.465	V
$V_{DDA}$	Analog Supply Voltage		3.135	3.3	3.465	V
$V_{DDO}$	Output Supply Voltage		3.135	3.3	3.465	V
$I_{DD}$	Power Supply Current			40		mA
$I_{DDA}$	Analog Supply Current			10		mA
$I_{DDO}$	Output Supply Current			160		mA

**TABLE 4B. LVCMOS / LVTTL DC CHARACTERISTICS,  $V_{DD} = V_{DDA} = V_{DDO} = 3.3V \pm 5\%$ ,  $T_A = 0^\circ C$  TO  $70^\circ C$**

Symbol	Parameter	Test Conditions	Minimum	Typical	Maximum	Units
$V_{IH}$	Input High Voltage		2		$V_{DD} + 0.3$	V
$V_{IL}$	Input Low Voltage		-0.3		0.8	V
$I_{IH}$	Input High Current	DIV_SEL0, DIV_SEL1, FB_IN, MR/nOE	$V_{DD} = V_{IN} = 3.465V$		150	$\mu A$
		PLL_SEL	$V_{DD} = V_{IN} = 3.465V$		5	$\mu A$
$I_{IL}$	Input Low Current	DIV_SEL0, DIV_SEL1, FB_IN, MR/nOE	$V_{DD} = 3.465V, V_{IN} = 0V$	-5		$\mu A$
		PLL_SEL	$V_{DD} = 3.465V, V_{IN} = 0V$	-150		$\mu A$
$V_{OH}$	Output High Voltage; NOTE 1		2.6			V
$V_{OL}$	Output Low Voltage; NOTE 1				0.5	V

NOTE 1: Outputs terminated with  $50\Omega$  to  $V_{DDO}/2$ . See Parameter Measurement Information, *3.3V Output Load Test Circuit*.

**TABLE 4C. DIFFERENTIAL DC CHARACTERISTICS,  $V_{DD} = V_{DDA} = V_{DDO} = 3.3V \pm 5\%$ ,  $T_A = 0^\circ C$  TO  $70^\circ C$**

Symbol	Parameter	Test Conditions	Minimum	Typical	Maximum	Units
$I_{IH}$	Input High Current	CLK	$V_{DD} = V_{IN} = 3.465V$		150	$\mu A$
		nCLK	$V_{DD} = V_{IN} = 3.465V$		5	$\mu A$
$I_{IL}$	Input Low Current	CLK	$V_{DD} = 3.465, V_{IN} = 0V$	-5		$\mu A$
		nCLK	$V_{DD} = 3.465, V_{IN} = 0V$	-150		$\mu A$
$V_{PP}$	Peak-to-Peak Input Voltage		0.15		1.3	V
$V_{CMR}$	Common Mode Input Voltage; NOTE 1, 2		GND + 0.5		$V_{DD} - 0.85$	V

NOTE 1: Common mode voltage is defined as  $V_{IH}$ .

NOTE 2: For single ended applications, the maximum voltage for CLK, nCLK is  $V_{DD} + 0.3V$ .



**TABLE 5. AC CHARACTERISTICS,  $V_{DD} = V_{DDA} = V_{DDO} = 3.3V \pm 5\%$ ,  $T_A = 0^\circ C$  TO  $70^\circ C$**

Symbol	Parameter	Test Conditions	Minimum	Typical	Maximum	Units
$f_{MAX}$	Output Frequency		15.625		250	MHz
$t_{pLH}$	Propagation Delay, Low-to-High; NOTE 1	PLL_SEL=0V, $0MHz \leq f \leq 250MHz$	TBD		TBD	ns
$t(\theta)$	Static Phase Offset; NOTE 2	PLL_SEL = 3.3V, $f_{REF} = 133MHz$ , $f_{VCO} = 266MHz$		TBD $\pm 100$		ps
		PLL_SEL = 3.3V, $f_{REF} = 50MHz$ , $f_{VCO} = 100MHz$		TBD $\pm 100$		ps
$t_{sk(o)}$	Output Skew; NOTE 3, 4	Measured on rising edge at $V_{DDO}/2$			125	ps
$t_{jit(cc)}$	Cycle-to-Cycle Jitter; NOTE 4	Measured on rising edge at $V_{DDO}/2$		36		ps
$t_L$	PLL Lock Time				1	ms
$t_R$	Output Rise Time	20% to 80% @ 50MHz	400		950	ps
$t_F$	Output Fall Time	20% to 80% @ 50MHz	400		950	ps
odc	Output Duty Cycle	$f = 250MHz$		50		%

All parameters measured at  $f_{MAX}$  unless noted otherwise.

NOTE 1: Measured from the differential input crossing point to the output at  $V_{DDO}/2$ .

NOTE 2: Defined as the time difference between the input reference clock and the average feedback input signal when the PLL is locked and the input reference frequency is stable.

NOTE 3: Defined as skew between outputs at the same supply voltage and with equal load conditions.

Measured at  $V_{DDO}/2$ .

NOTE 4: This parameter is defined in accordance with JEDEC Standard 65.



**PARAMETER MEASUREMENT INFORMATION**

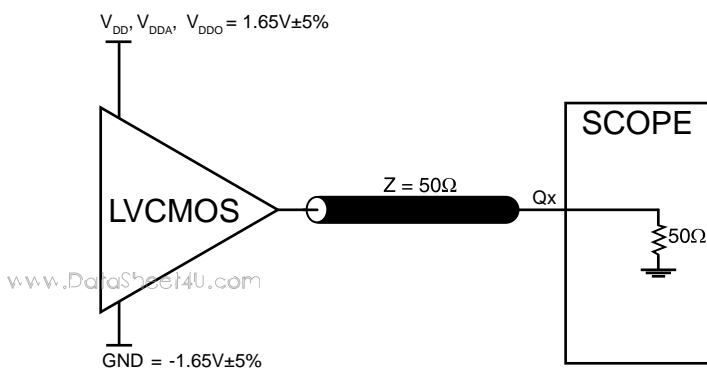

**3.3V OUTPUT LOAD AC TEST CIRCUIT**

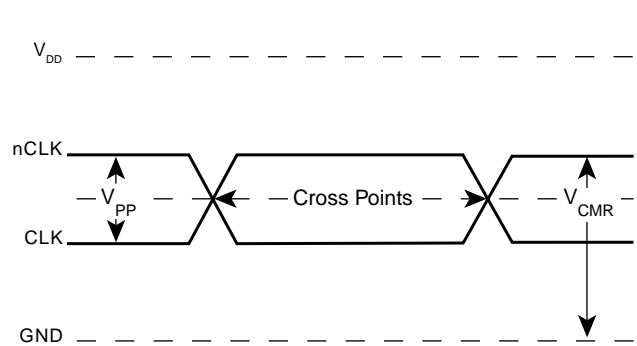

**DIFFERENTIAL INPUT LEVEL**

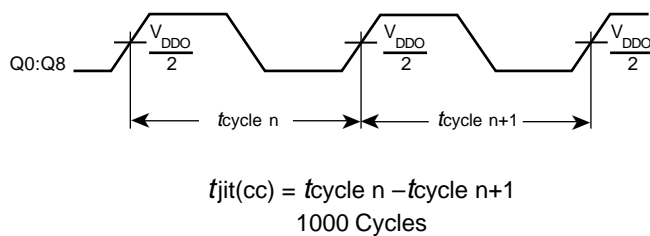

**CYCLE-TO-CYCLE JITTER**

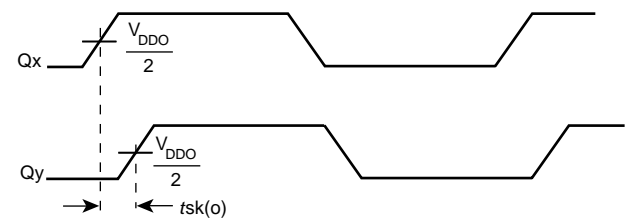

**OUTPUT SKEW**

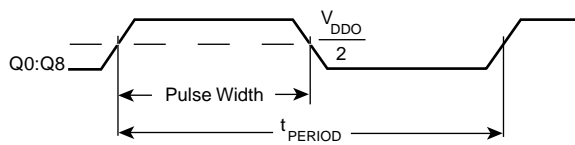

$$odc = \frac{t_{PW}}{t_{PERIOD}}$$

**odc & t<sub>PERIOD</sub>**

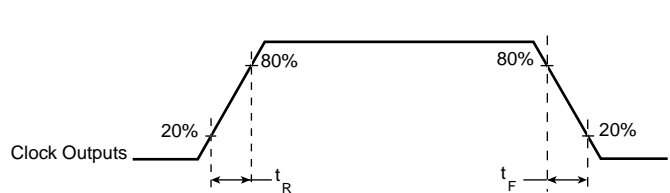

**OUTPUT RISE/FALL TIME**

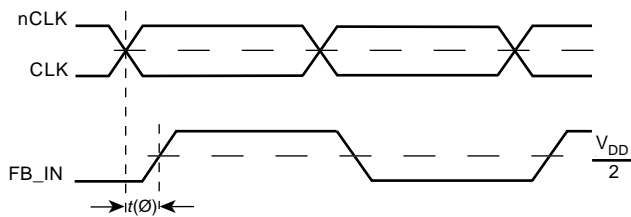

t(∅) mean = Static Phase Offset

(where t(∅) is any random sample, and t(∅) mean is the average of the sampled cycles measured on controlled edges)

**STATIC PHASE OFFSET**

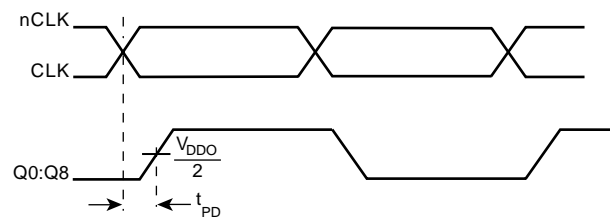

**PROPAGATION DELAY**



## APPLICATION INFORMATION

### WIRING THE DIFFERENTIAL INPUT TO ACCEPT SINGLE ENDED LEVELS

Figure 1 shows how the differential input can be wired to accept single ended levels. The reference voltage  $V_{REF} = V_{DD}/2$  is generated by the bias resistors R1, R2 and C1. This bias circuit should be located as close as possible to the input pin. The ratio

of R1 and R2 might need to be adjusted to position the  $V_{REF}$  in the center of the input voltage swing. For example, if the input clock swing is only 2.5V and  $V_{DD} = 3.3V$ ,  $V_{REF}$  should be 1.25V and  $R2/R1 = 0.609$ .

www.DataSheet4U.com

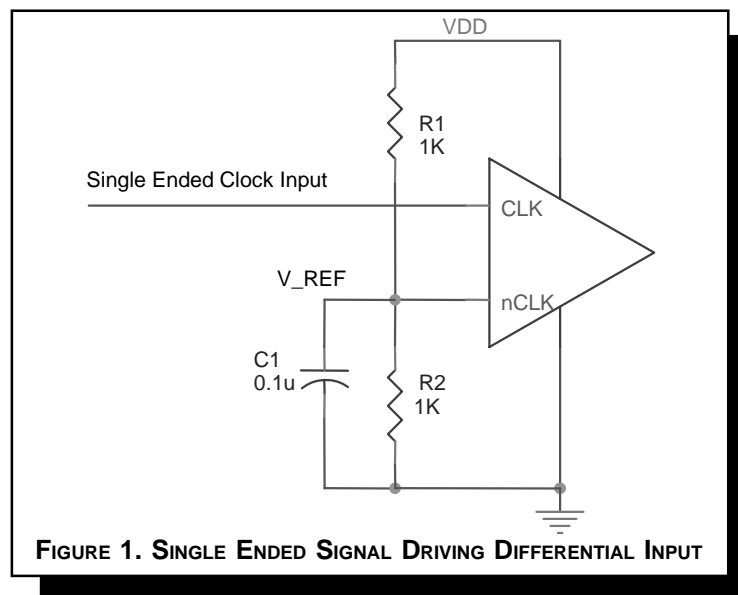

### POWER SUPPLY FILTERING TECHNIQUES

As in any high speed analog circuitry, the power supply pins are vulnerable to random noise. The ICS8602 provides separate power supplies to isolate any high switching noise from the outputs to the internal PLL.  $V_{DD}$ ,  $V_{DDA}$ , and  $V_{DDO}$  should be individually connected to the power supply plane through vias, and bypass capacitors should be used for each pin. To achieve optimum jitter performance, power supply isolation is required. Figure 2 illustrates how a 10Ω resistor along with a 10µF and a .01µF bypass capacitor should be connected to each  $V_{DDA}$  pin.

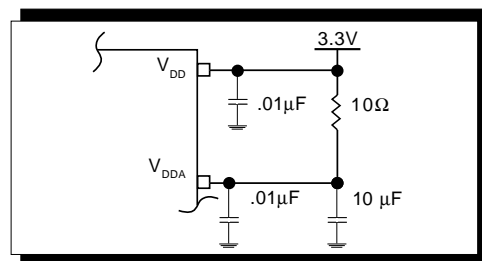



**DIFFERENTIAL CLOCK INPUT INTERFACE**

The CLK/nCLK accepts LVDS, LVPECL, LVHSTL, SSTL, HCSSL and other differential signals. Both  $V_{SWING}$  and  $V_{OH}$  must meet the  $V_{PP}$  and  $V_{CMR}$  input requirements. Figures 3A to 3D show interface examples for the HiPerClockS CLK/nCLK input driven by the most common driver types. The input interfaces suggested

here are examples only. Please consult with the vendor of the driver component to confirm the driver termination requirements. For example in *Figure 3A*, the input termination applies for ICS HiPerClockS LVHSTL drivers. If you are using an LVHSTL driver from another vendor, use their termination recommendation.

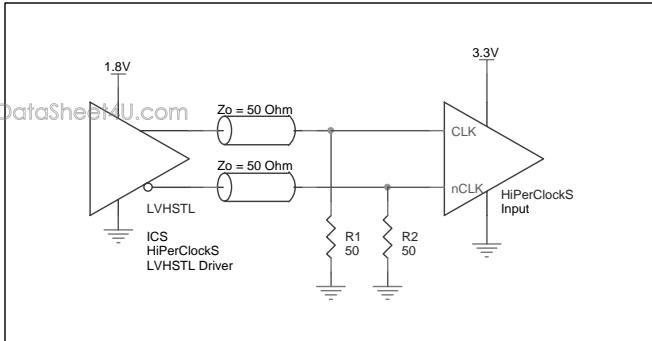

**FIGURE 3A. HiPerClockS CLK/nCLK INPUT DRIVEN BY ICS HiPerClockS LVHSTL DRIVER**

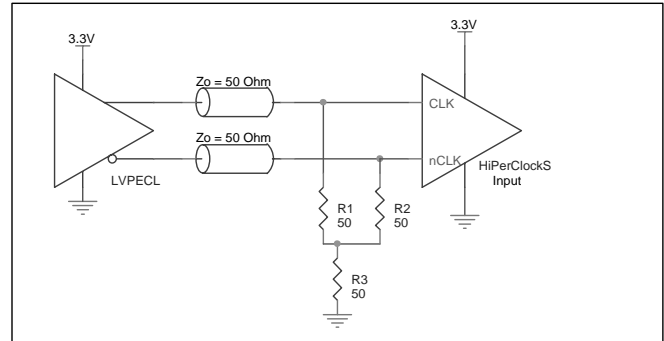

**FIGURE 3B. HiPerClockS CLK/nCLK INPUT DRIVEN BY 3.3V LVPECL DRIVER**

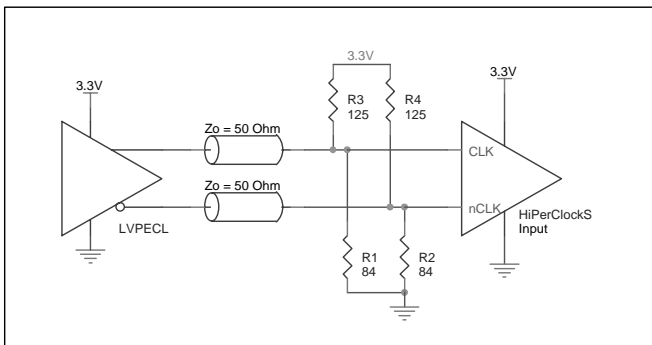

**FIGURE 3C. HiPerClockS CLK/nCLK INPUT DRIVEN BY 3.3V LVPECL DRIVER**

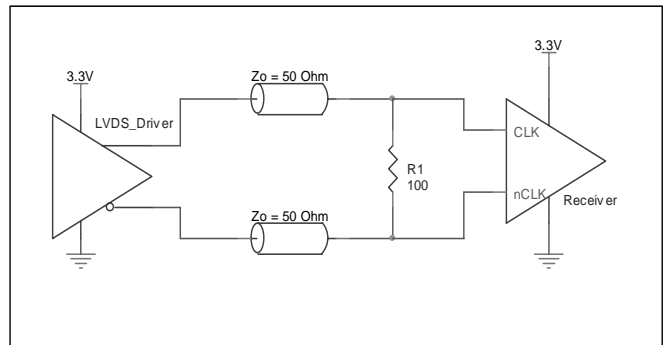

**FIGURE 3D. HiPerClockS CLK/nCLK INPUT DRIVEN BY 3.3V LVDS DRIVER**



**RELIABILITY INFORMATION**

**TABLE 6.  $\theta_{JA}$  VS. AIR FLOW TABLE**

$\theta_{JA}$ by Velocity (Linear Feet per Minute)			
	<b>0</b>	<b>200</b>	<b>500</b>
Single-Layer PCB, JEDEC Standard Test Boards	67.8°C/W	55.9°C/W	50.1°C/W
Multi-Layer PCB, JEDEC Standard Test Boards	47.9°C/W	42.1°C/W	39.4°C/W

**NOTE:** Most modern PCB designs use multi-layered boards. The data in the second row pertains to most designs.

**TRANSISTOR COUNT**

The transistor count for ICS8602 is: 1828





PACKAGE OUTLINE - Y SUFFIX

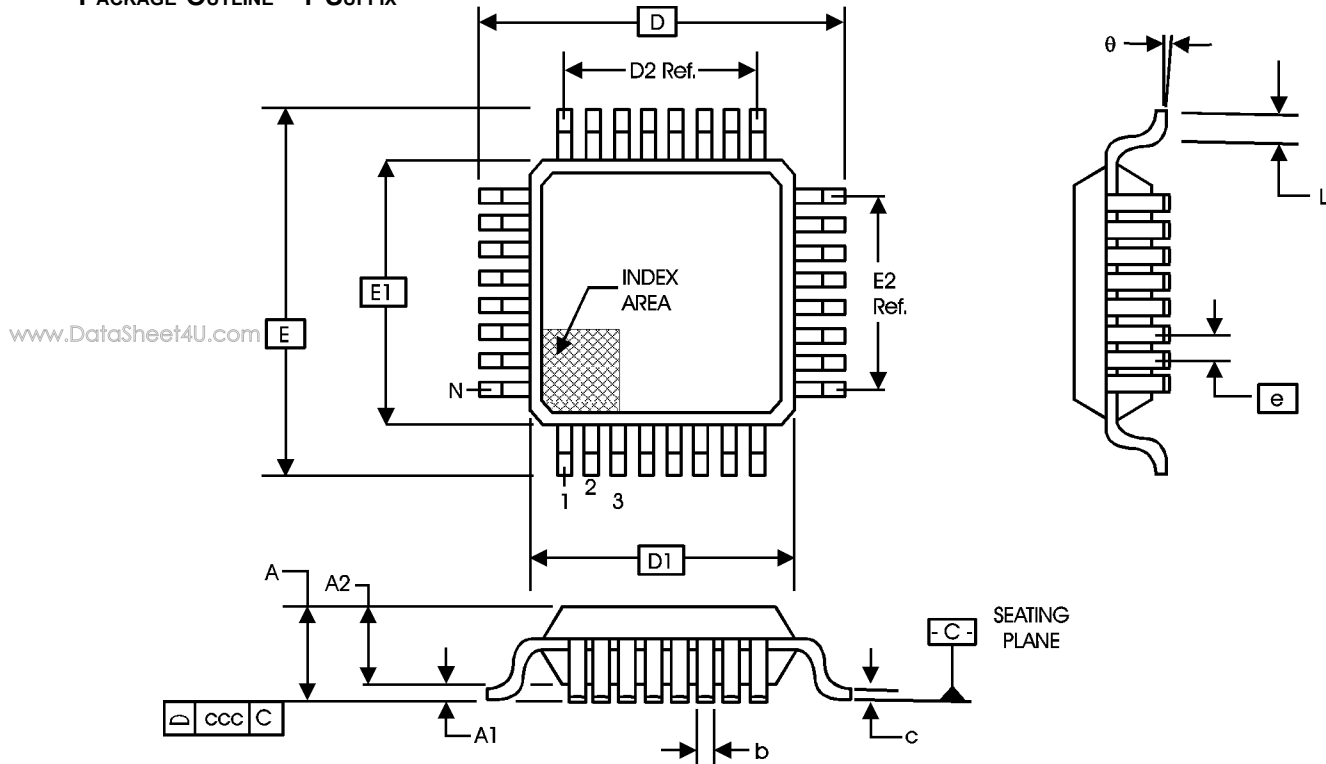

TABLE 7. PACKAGE DIMENSIONS

JEDEC VARIATION ALL DIMENSIONS IN MILLIMETERS			
SYMBOL	BBA		
	MINIMUM	NOMINAL	MAXIMUM
N	32		
A	--	--	1.60
A1	0.05	--	0.15
A2	1.35	1.40	1.45
b	0.30	0.37	0.45
c	0.09	--	0.20
D	9.00 BASIC		
D1	7.00 BASIC		
D2	5.60 Ref.		
E	9.00 BASIC		
E1	7.00 BASIC		
E2	5.60 Ref.		
e	0.80 BASIC		
L	0.45	0.60	0.75
θ	0°	--	7°
ccc	--	--	0.10

Reference Document: JEDEC Publication 95, MS-026



Integrated  
Circuit  
Systems, Inc.

# PRELIMINARY

## ICS8602 ZERO DELAY, DIFFERENTIAL-TO-LVCMOS/LVTTL CLOCK GENERATOR

**TABLE 8. ORDERING INFORMATION**

Part/Order Number	Marking	Package	Count	Temperature
ICS8602BY	ICS8602BY	32 Lead LQFP	250 per tray	0°C to 70°C
ICS8602BYT	ICS8602BY	32 Lead LQFP on Tape and Reel	1000	0°C to 70°C

[www.DataSheet4U.com](http://www.DataSheet4U.com)

While the information presented herein has been checked for both accuracy and reliability, Integrated Circuit Systems, Incorporated (ICS) assumes no responsibility for either its use or for infringement of any patents or other rights of third parties, which would result from its use. No other circuits, patents, or licenses are implied. This product is intended for use in normal commercial applications. Any other applications such as those requiring extended temperature range, high reliability, or other extraordinary environmental requirements are not recommended without additional processing by ICS. ICS reserves the right to change any circuitry or specifications without notice. ICS does not authorize or warrant any ICS product for use in life support devices or critical medical instruments.