

# Filtered Low Noise Amplifier

## SPECTRUM MICROWAVE

P/N: 310-025103-011

### For GPS Applications

1227 MHz/1575 MHz

This series of Low Noise Amplifiers provides a filtered, low-noise gain solution ideal for applications where higher reliability is critical. These filtered low noise amplifiers are designed to reduce out-of-band interference while achieving high dynamic range.

A pair of diplexed 3-pole ceramic filters select only the desired GPS signals while the low-noise gain stage maintains the receiving system's sensitivity.

The LNA rejects undesired signals by at least 40 dB at 1050, 1410, and 1710 MHz. See the graphs on Page 2 for return loss, rejections, and gain of a typical unit.

The preamplifier is powered by DC voltage applied to the center conductor of the output connector. Optionally, the unit can be powered through an external DC bias connector.

### Features and Benefits

- Noise figure 1.6 dB typical
- Double-diplexed preamp filters
- Lightweight aluminum housing
- Dual band (L1 and L2) performance
- Coaxial and external bias options
- Environmental sealing available
- Application specific packages available
- Suitable for new L2-C signals
- L5 configurations available upon request



P/N: 310-025103-011

### Typical Performance Specifications

Frequency . . . . .	1575.42 MHz (L1) 1227.60 MHz (L2)
Bandwidth . . . . .	30 MHz min.
Noise figure . . . . .	2.0 dB max.
VSWR . . . . .	1.5:1 max.
Gain . . . . .	14 dB min.
Gain Flatness . . . . .	+/-0.5 dB
Rejection . . . . .	40 dB @ 1050, 1410, 1710 MHz
Bias . . . . .	Coaxial Bias
DC Power . . . . .	5-16 VDC
Temperature Range . . . . .	-40°C to +71°C

All specifications above measured at 25°C

### Dimensions and Connections

- Antenna port J1
- Receiver port J2
- SMA type female connectors
- 2.20"Ø x 0.080"H excluding connectors  
Chassis is machined aluminum with a nickel plate finish.

### Block Diagram

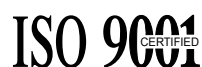
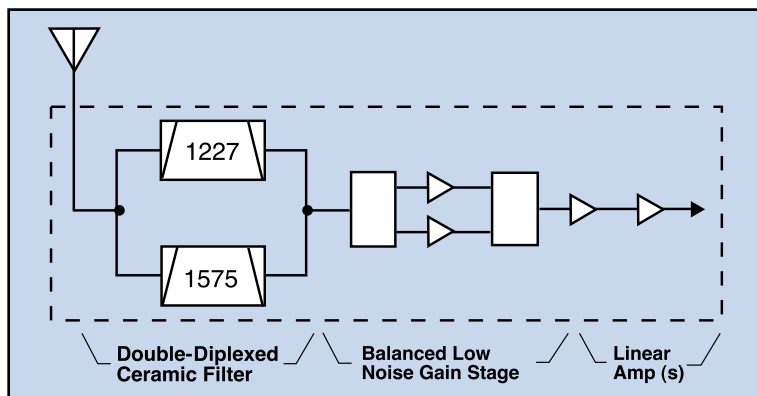

# Filtered Low Noise Amplifier

1227 MHz/1575 MHz

### Amplifier Gain

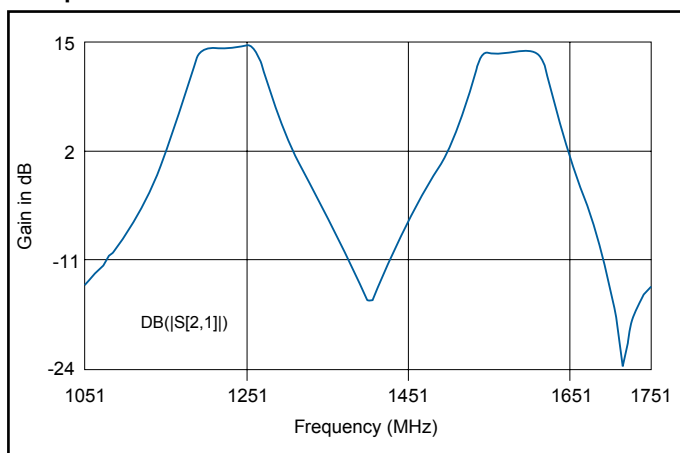

### Return Loss

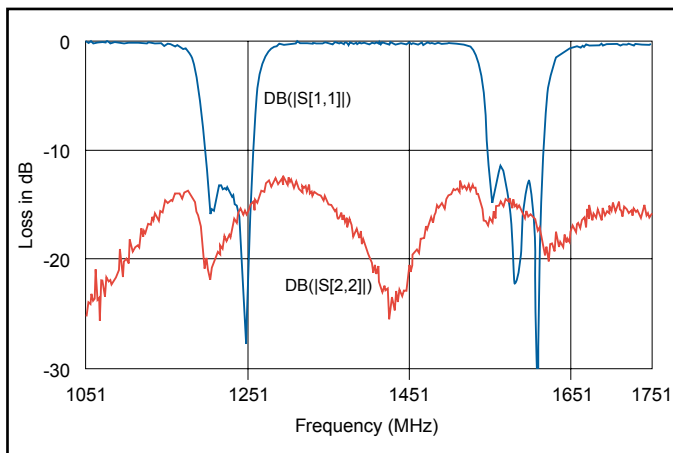

### Dimensions (inches)

