



TAI-SAW TECHNOLOGY CO., LTD.

No. 3, Industrial 2nd Rd., Ping-Chen Industrial District,
Taoyuan, 324, Taiwan, R.O.C.

TEL: 886-3-4690038 FAX: 886-3-4697532

E-mail: tstsales@mail.taisaw.com Web: www.taisaw.com

Approval Sheet For Product Specification

Issued Date: 2005 Jan. 31 (REV NO.: 1.1)

Product Name: 7.0x5.0 PECL Crystal Oscillator 53.125 MHz

TST Parts No.: TW0153A

Customer Parts No.: _____

Company: _____
Division: _____
Approved by : _____
Date: _____

Checked by: _____ Robert Chang

Approval by: _____ TF Yang

Date: _____ 2005/01/31



TAI-SAW TECHNOLOGY CO., LTD.

No. 3, Industrial 2nd Rd., Ping-Chen Industrial District,
Taoyuan, 324, Taiwan, R.O.C.

TEL: 886-3-4690038 FAX: 886-3-4697532

E-mail: tstsales@mail.taisaw.com Web: www.taisaw.com

7.0x5.0 PECL Crystal Oscillator 53.125 MHz

MODEL NO.: TW0153A

REV. NO.:1.1

Features:

1. SMD type Crystal Oscillator.
2. High Frequency XO / 3.3V Operation / Complementary PECL Output
3. Main application: WLAN, SONET/SDH/DWDM, Gigabite Ethernet, Storage Area Network, Digital Video

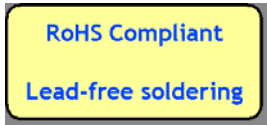

Electrical Specifications:

Measurement shall be made under room temperature and humidity at below conditions.

Temperature: 25+/-3 °C

Humidity: Below 70% RH

Operating Temperature: 0 °C to +70 °C

Storage Temperature: -40 °C to +85 °C

Characteristics	Units	Minimum	Typical	Maximum
Center Frequency	MHz	-	53.125	-
Frequency Stability (#note 1)	ppm	-50	-	50
Load	Ω	-	50	-
Supply Voltage (Vdd)	VDC	-	3.3+/-5%	-
Current Consumption (Loaded Output)	mA	-	-	85
Output				
Output Level		PECL Level (Complementary)		
Output Logic High	VDC	$V_{dd} - 1.025$	-	--
Output Logic Low	VDC	--	-	$V_{dd} - 1.620$
Symmetry (Duty Cycle)	%	45%	50%	55%
Rise Time (10%→90% VDD)	nSec	--	0.6	1.5
Fall Time (90%→10% VDD)	nSec	--	0.6	1.5
Integrated Jitter RMS (Integrated 12kHz to 20MHz)	pSec	-	0.3	-
Enable/Disable Function		No OE Function		
Package size	mm	7.0x5.0x1.8		

#Note 1: Frequency stability includes 25°C tolerance, operating temperature range, aging and voltage or load change.

Mechanical Dimensions (mm):

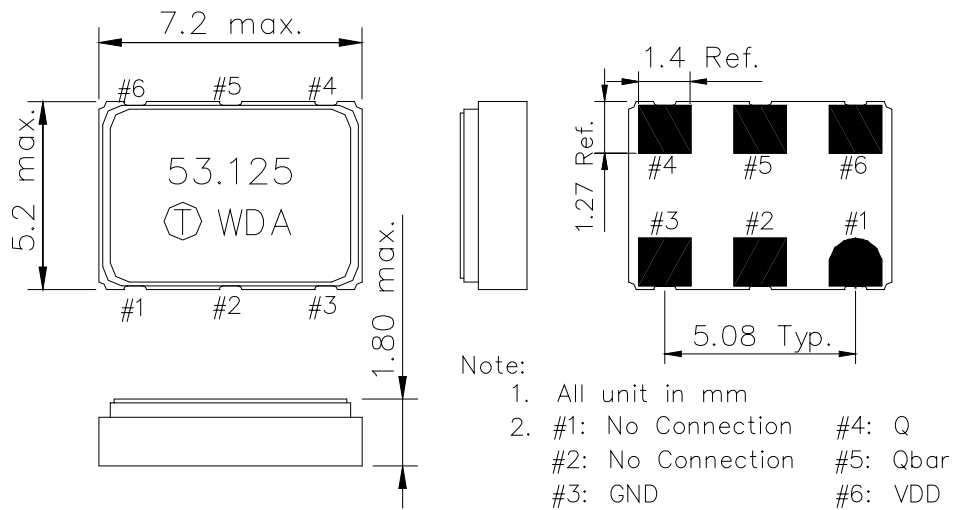

Marking:

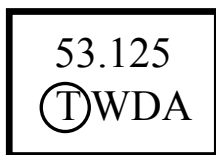

Line 1: 53.125

Line 2: T WDA

Where W stand for product code and D for date code

1. Product Code Table:

Year	2001 2005	2002 2006	2003 2007	2004 2008
Product Code	W	w	<u>W</u>	<u>w</u>

2. Date Code Table:

WK01	WK02	WK03	WK04	WK05	WK06	WK07	WK08	WK09	WK10	WK11	WK12	WK13
A	B	C	D	E	F	G	H	I	J	K	L	M
WK14	WK15	WK16	WK17	WK18	WK19	WK20	WK21	WK22	WK23	WK24	WK25	WK26
N	O	P	Q	R	S	T	U	V	W	X	Y	Z
WK27	WK28	WK29	WK30	WK31	WK32	WK33	WK34	WK35	WK36	WK37	WK38	WK39
a	b	c	d	e	f	g	h	i	j	k	l	m
WK40	WK41	WK42	WK43	WK44	WK45	WK46	WK47	WK48	WK49	WK50	WK51	WK52
n	o	p	q	r	s	t	u	v	w	x	y	z

Tape & Reel: Packing Quantity: 1k /Reel

REEL DIMENSION (unit: mm)

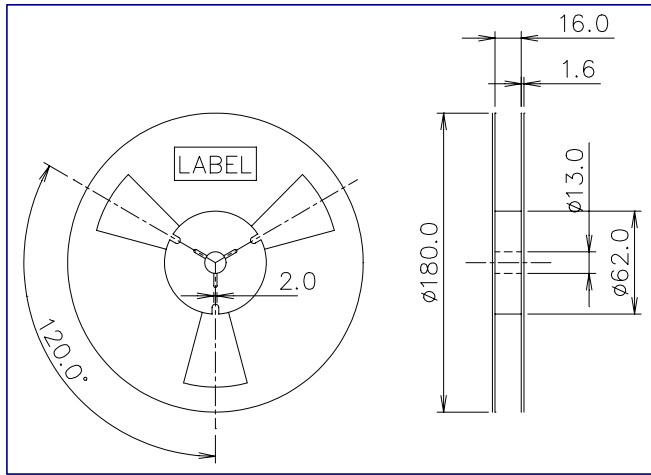

TAPE DIMENSION (unit: mm)

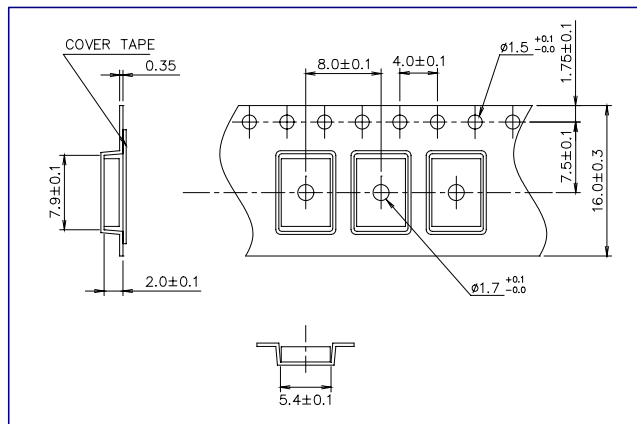

PACKING DIRECTION

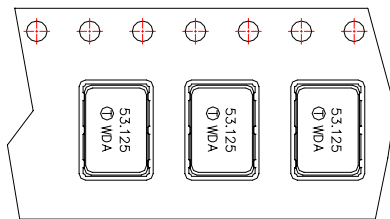

Soldering Reflow Profile

