

## FEATURES

- Fully Enhances N-Channel Power MOSFETs
- 8 $\mu$ A  $I_Q$  Standby Current
- 85 $\mu$ A  $I_Q$  ON Current
- No External Charge Pump Capacitors
- 4.5V to 18V Supply Range
- Short-Circuit Protection
- Thermal Shutdown via PTC Thermistor
- Status Output Indicates Shutdown
- Available in 8-Pin SOIC and PDIP Packages

## APPLICATIONS

- Laptop Computer Power Switching
- SCSI Termination Power Switching
- Cellular Telephone Power Management
- Battery Charging and Management
- High Side Industrial and Automotive Switching
- Stepper Motor and DC Motor Control

## DESCRIPTION

The LTC<sup>®</sup>1154 single high side gate driver allows using low cost N-channel FETs for high side switching applications. An internal charge pump boosts the gate drive voltage above the positive rail, fully enhancing an N-channel MOS switch with no external components. Micropower operation, with 8 $\mu$ A standby current and 85 $\mu$ A operating current, allows use in virtually all systems with maximum efficiency.

Included on chip is programmable overcurrent sensing. A time delay can be added to prevent false triggering on high inrush current loads. An active high shutdown input is also provided and interfaces directly to a standard PTC thermistor for thermal shutdown. An open-drain output is provided to report switch status to the  $\mu$ P. An active low enable input is provided to control multiple switches in banks.

The LTC1154 is available in both 8-pin DIP and 8-pin SOIC packages.

LT, LT, LTC, LTM, Linear Technology and the Linear logo are registered trademarks of Linear Technology Corporation. All other trademarks are the property of their respective owners.

## TYPICAL APPLICATION

**Ultralow Voltage Drop High Side Switch with Short-Circuit Protection**

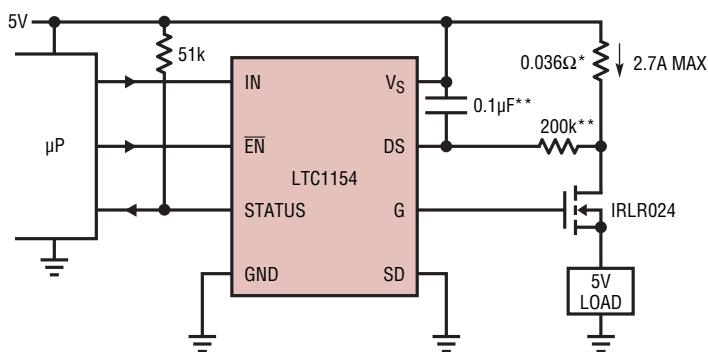

LTC1154 • TA01

**Standby Supply Current**

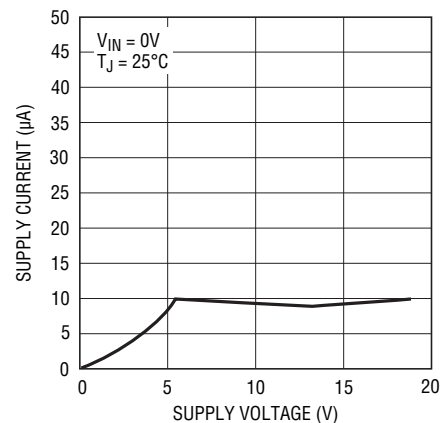

LTC1153 • TA02

ALL COMPONENTS SHOWN ARE SURFACE MOUNT.

\* IMS026 INTERNATIONAL MANUFACTURING SERVICE, INC. (401) 683-9700

\*\* NOT REQUIRED IF LOAD IS RESISTIVE OR INDUCTIVE.

# LTC1154

## ABSOLUTE MAXIMUM RATINGS

(Note 1)

Supply Voltage .....	22V
Input Voltage.....	( $V_S + 0.3V$ ) to (GND - 0.3V)
Enable Input Voltage .....	( $V_S + 0.3V$ ) to (GND - 0.3V)
Gate Voltage.....	( $V_S + 24V$ ) to (GND - 0.3V)
Status Output Voltage .....	15V
Current (Any Pin) .....	50mA

Operating Temperature	
LTC1154C .....	0°C to 70°C
LTC1154H .....	-40°C to 150°C
Storage Temperature.....	-65°C to 150°C
Lead Temperature (Soldering, 10 sec.) .....	300°C

## PIN CONFIGURATION

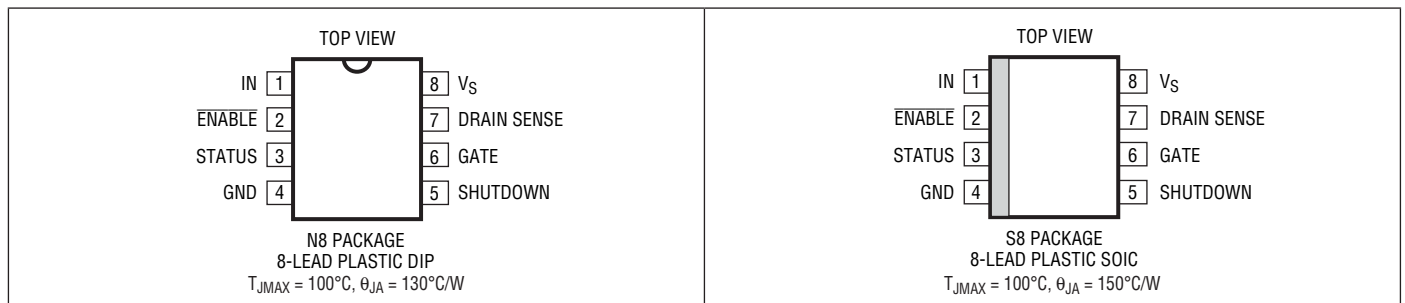

## ORDER INFORMATION

LEAD FREE FINISH	TAPE AND REEL	PART MARKING	PACKAGE DESCRIPTION	TEMPERATURE RANGE
LTC1154CN8#PBF	LTC1154CN8#TRPBF		8-Lead Plastic DIP	0°C to 70°C
LTC1154CS8#PBF	LTC1154CS8#TRPBF	1154	8-Lead Plastic SIOC	0°C to 70°C
LTC1154HS8#PBF	LTC1154HS8#TRPBF	1154H	8-Lead Plastic SIOC	-40°C to 150°C
LEAD BASED FINISH	TAPE AND REEL	PART MARKING	PACKAGE DESCRIPTION	TEMPERATURE RANGE
LTC1154CN8	LTC1154CN8#TR		8-Lead Plastic DIP	0°C to 70°C
LTC1154CS8	LTC1154CS8#TR	1154	8-Lead Plastic SIOC	0°C to 70°C
LTC1154HS8	LTC1154HS8#TR	1154H	8-Lead Plastic SIOC	-40°C to 150°C

Consult LTC Marketing for parts specified with wider operating temperature ranges.

For more information on lead free part marking, go to: <http://www.linear.com/leadfree/>

For more information on tape and reel specifications, go to: <http://www.linear.com/tapeandreel/>

**ELECTRICAL CHARACTERISTICS** The ● denotes the specifications which apply over the full operating temperature range, otherwise specifications are at  $T_A = 25^\circ\text{C}$ .  $V_S = 4.5\text{V}$  to  $18\text{V}$ ,  $T_A = 25^\circ\text{C}$ ,  $V_{EN} = 0\text{V}$ ,  $V_{SD} = 0\text{V}$  unless otherwise noted.

SYMBOL	PARAMETER	CONDITIONS	MIN	TYP	MAX	UNITS
$V_S$	Supply Voltage		● 4.5		18	V
$I_Q$	Quiescent Current OFF	$V_S = 5\text{V}$ , $V_{IN} = 0\text{V}$		8	20	$\mu\text{A}$
	Quiescent Current ON	$V_S = 5\text{V}$ , $V_{IN} = 5\text{V}$		85	120	$\mu\text{A}$
	Quiescent Current ON	$V_S = 12\text{V}$ , $V_{IN} = 5\text{V}$		180	400	$\mu\text{A}$
$V_{INH}$	Input High Voltage		● 2			V

1154fb

## ELECTRICAL CHARACTERISTICS

The ● denotes the specifications which apply over the full operating temperature range, otherwise specifications are at  $T_A = 25^\circ\text{C}$ .  $V_S = 4.5\text{V to }18\text{V}$ ,  $T_A = 25^\circ\text{C}$ ,  $V_{EN} = 0\text{V}$ ,  $V_{SD} = 0\text{V}$  unless otherwise noted.

SYMBOL	PARAMETER	CONDITIONS	MIN	TYP	MAX	UNITS	
$V_{INL}$	Input Low Voltage		●		0.8	V	
$I_{IN}$	Input Current	$0\text{V} < V_{IN} < V_S$	●		$\pm 1$	$\mu\text{A}$	
$C_{IN}$	Input Capacitance			5		pF	
$V_{ENH}$	ENABLE Input High Voltage		●	3.5	2.6	V	
$V_{ENL}$	ENABLE Input Low Voltage		●	1	0.6	V	
$I_{EN}$	ENABLE Input Current	$0\text{V} < V_{IN} < V_S$	●		$\pm 1$	$\mu\text{A}$	
$V_{SDH}$	Shutdown Input High Voltage		●	2		V	
$V_{SDL}$	Shutdown Input Low Voltage		●		0.8	V	
$I_{SD}$	Shutdown Input Current	$0\text{V} < V_{IN} < V_S$	●		$\pm 1$	$\mu\text{A}$	
$V_{SEN}$	Drain Sense Threshold Voltage		●	80 75	100 100	120 125	mV mV
$I_{SEN}$	Drain Sense Input Current	$0\text{V} < V_{SEN} < V_S$	●		$\pm 0.1$	$\mu\text{A}$	
$V_{GATE} - V_S$	Gate Voltage Above Supply	$V_S = 5\text{V}$ $V_S = 6\text{V}$ $V_S = 12\text{V}$	● ● ●	6 7.5 15	7 8.3 18	9 15 25	V V V
$V_{STAT}$	Status Output Low Voltage	$I_{STAT} = 400\mu\text{A}$	●		0.05	0.4	V
$I_{STAT}$	Status Output Leakage Current	$V_{STAT} = 12\text{V}$	●		1		$\mu\text{A}$
$t_{ON}$	Turn-ON Time	$V_S = 5\text{V}$ , $C_{GATE} = 1000\text{pF}$ Time for $V_{GATE} > V_S + 2\text{V}$ Time for $V_{GATE} > V_S + 5\text{V}$		30 100	110 450	300 1000	$\mu\text{s}$ $\mu\text{s}$
		$V_S = 12\text{V}$ , $C_{GATE} = 1000\text{pF}$ Time for $V_{GATE} > V_S + 5\text{V}$ Time for $V_{GATE} > V_S + 10\text{V}$		20 50	80 160	200 500	$\mu\text{s}$ $\mu\text{s}$
$t_{OFF}$	Turn-OFF Time	$V_S = 5\text{V}$ , $C_{GATE} = 1000\text{pF}$ , Time for $V_{GATE} < 1\text{V}$		10	36	60	$\mu\text{s}$
		$V_S = 12\text{V}$ , $C_{GATE} = 1000\text{pF}$ , Time for $V_{GATE} < 1\text{V}$		10	28	60	$\mu\text{s}$
$t_{SC}$	Short-Circuit Turn-OFF Time	$V_S = 5\text{V}$ , $C_{GATE} = 1000\text{pF}$ , Time for $V_{GATE} < 1\text{V}$		5	25	40	$\mu\text{s}$
		$V_S = 12\text{V}$ , $C_{GATE} = 1000\text{pF}$ , Time for $V_{GATE} < 1\text{V}$		5	23	40	$\mu\text{s}$
$t_{SD}$	Shutdown Turn-OFF Time	$V_S = 5\text{V}$ , $C_{GATE} = 1000\text{pF}$ , Time for $V_{GATE} < 1\text{V}$			17	40	$\mu\text{s}$
		$V_S = 12\text{V}$ , $C_{GATE} = 1000\text{pF}$ , Time for $V_{GATE} < 1\text{V}$			13	35	$\mu\text{s}$

**Note 1:** Stresses beyond those listed under Absolute Maximum Ratings may cause permanent damage to the device. Exposure to any Absolute Maximum Rating condition for extended periods may affect device reliability and lifetime.

## TYPICAL PERFORMANCE CHARACTERISTICS

### Standby Supply Current

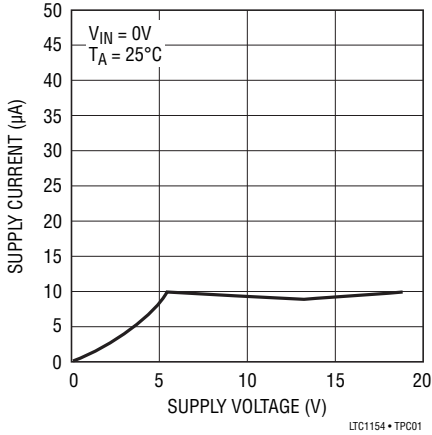

### Supply Current ON

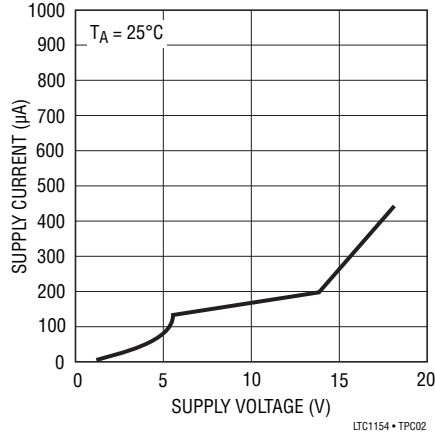

### High Side Gate Voltage

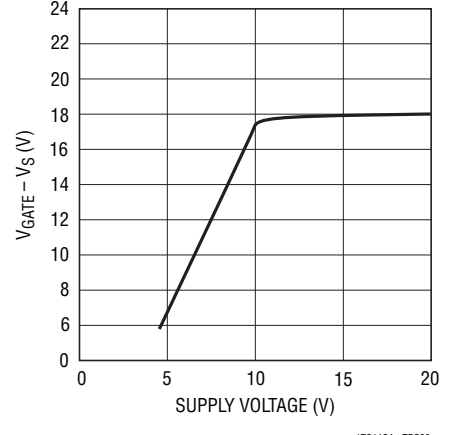

### Input Threshold Voltage

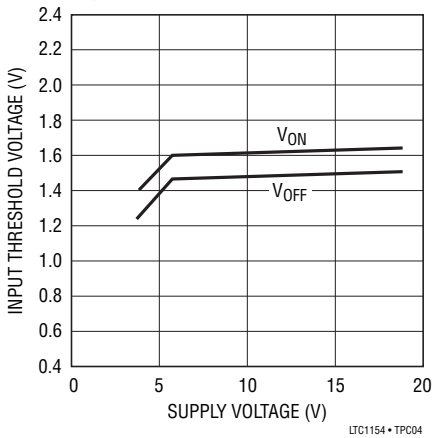

### Drain Sense Threshold Voltage

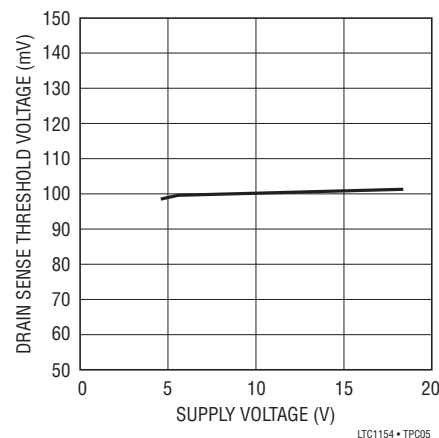

### Low Side Gate Voltage

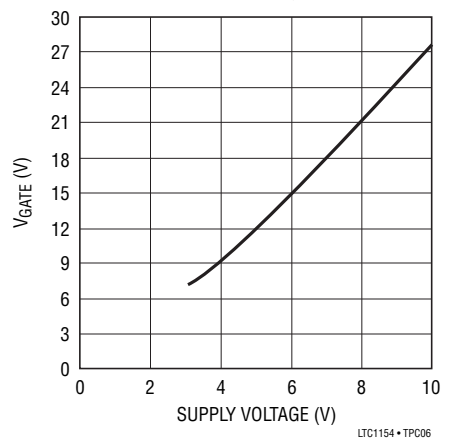

### Turn-ON Time

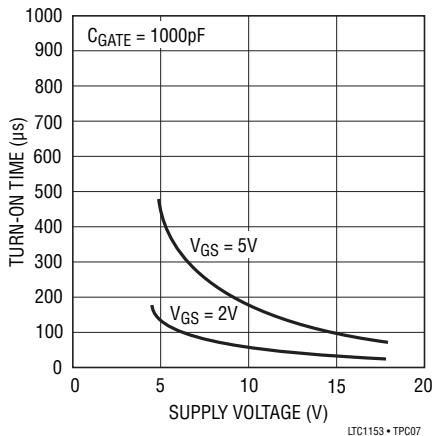

### Turn-OFF Time

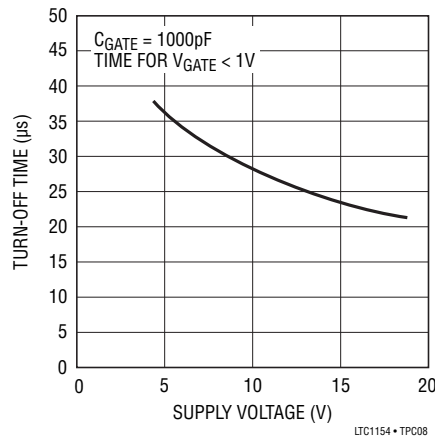

### Short-Circuit Turn-OFF Delay Time

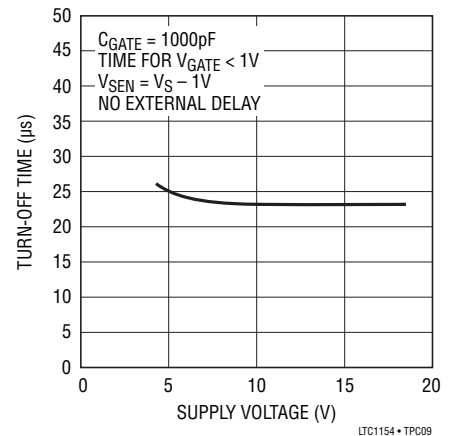

## TYPICAL PERFORMANCE CHARACTERISTICS

### Standby Supply Current

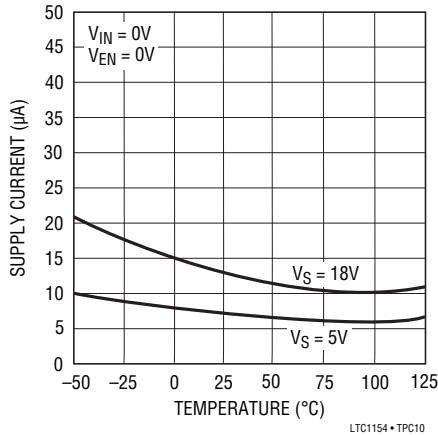

LTC1154 • TPC10

### Supply Current ON

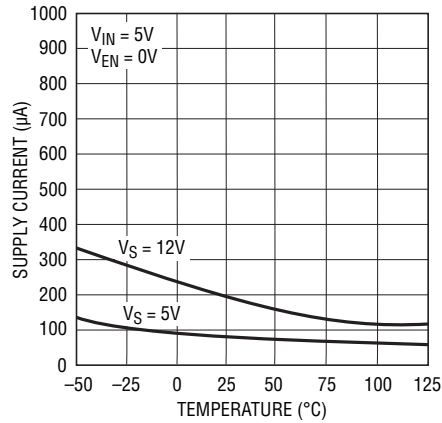

LTC1154 • TPC11

### Input ON Threshold Voltage

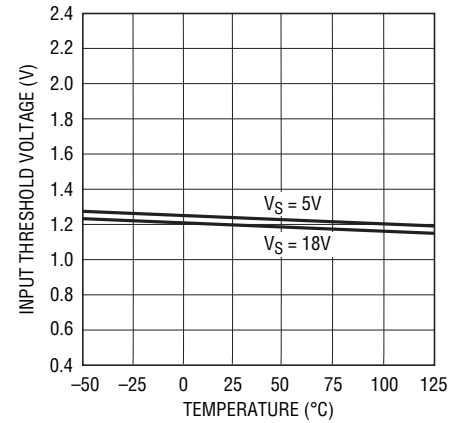

LTC1154 • TPC12

### Shutdown Threshold Voltage

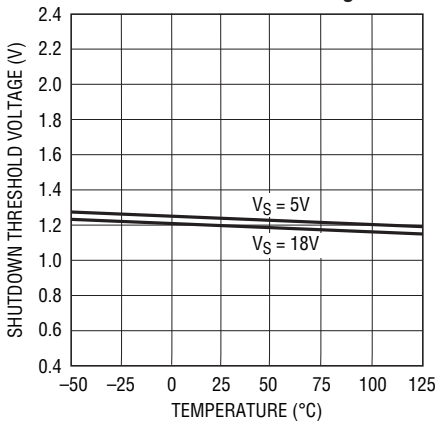

LTC1154 • TPC13

### ENABLE Threshold Voltage

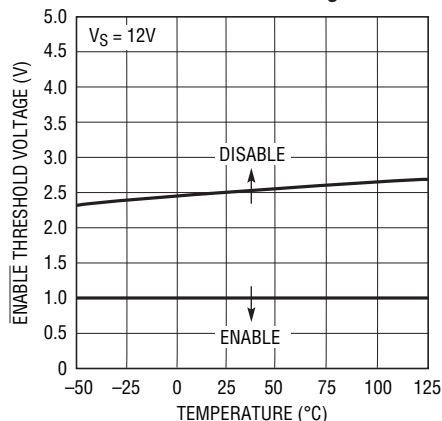

LTC1154 • TPC14

### Gate Drive Current

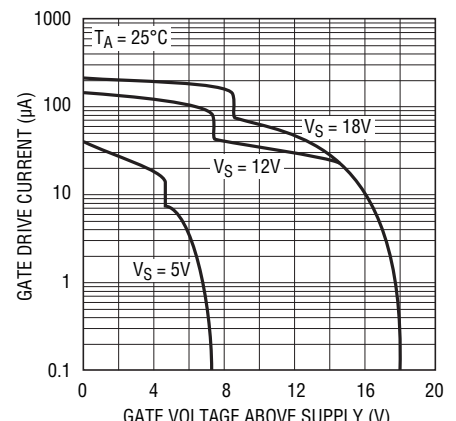

LTC1154 • TPC15

## PIN FUNCTIONS

### Input and Shutdown Pins

The LTC1154 input pin is active high and activates all of the protection and charge pump circuitry when switched ON. The shutdown pin is designed to immediately disable the switch if a secondary fault condition (over temperature, etc.) is detected. The LTC1154 logic and shutdown inputs are high impedance CMOS gates with ESD protection diodes to ground and supply and therefore should not be forced beyond the power supply rails. The shutdown pin should be connected to ground when not in use.

### ENABLE Input Pin

The  $\overline{\text{ENABLE}}$  input can be used to enable a number of LTC1154 high side switches in banks or to provide a secondary means of control. It can also act as an inverting input. The  $\overline{\text{ENABLE}}$  input is a high impedance CMOS gate with ESD clamp diodes to ground and supply and therefore should not be forced beyond the power supply rails. This pin should be grounded when not in use.

## PIN FUNCTIONS

### Gate Drive Pin

The gate drive pin is either driven to ground when the switch is turned OFF or driven above the supply rail when the switch is turned ON. This pin is a relatively high impedance when driven above the rail (the equivalent of a few hundred k $\Omega$ ). Care should be taken to minimize any loading of this pin by parasitic resistance to ground or supply.

### Supply Pin

The supply pin of the LTC1154 serves two vital purposes. The first is obvious: it powers the input, gate drive, regulation and protection circuitry. The second purpose is less obvious: it provides a Kelvin connection to the top of the drain sense resistor for the internal 100mV reference.

The LTC1154 is designed to be continuously powered so that the gate of the MOSFET is actively driven at all times. If it is necessary to remove power from the supply pin and then re-apply it, the input pin (or enable pin) should be cycled a few milliseconds *after* the power is re-applied to reset the input latch and protection circuitry. Also, the input and enable pins should be isolated with 10k resistors to limit the current flowing through the ESD protection diodes to the supply pin.

*The supply pin of the LTC1154 should never be forced below ground as this may result in permanent damage to the device. A 300 $\Omega$  resistor should be inserted in series with the ground pin if negative supply voltage transients are anticipated.*

### Drain Sense Pin

The drain sense pin is compared against the supply pin voltage. If the voltage at this pin is more than 100mV below the supply pin, the input latch will be reset and the MOSFET gate will be quickly discharged. Cycle the input, or  $\overline{\text{ENABLE}}$  input, to reset the short-circuit latch and turn the MOSFET back on.

This pin is also a high impedance CMOS gate with ESD protection and therefore should not be forced beyond the power supply rails. To defeat the overcurrent protection, short the drain sense to supply.

Some loads, such as large supply capacitors, lamps, or motors require high inrush currents. An RC time delay can be added between the sense resistor and the drain sense pin to ensure that the drain sense circuitry does not false-trigger during start-up. This time constant can be set from a few microseconds to many seconds. However, very long delays may put the MOSFET in risk of being destroyed by a short-circuit condition. (see Applications Information Section).

### Status Pin

The status pin is an open-drain output which is driven low whenever a fault condition is detected. A 51k pull-up resistor should be connected between this output and a logic supply. The status pins of multiple LTC1154s can be OR'd together if independent fault sensing is not required. No connection is required to this pin when not in use.

## BLOCK DIAGRAM

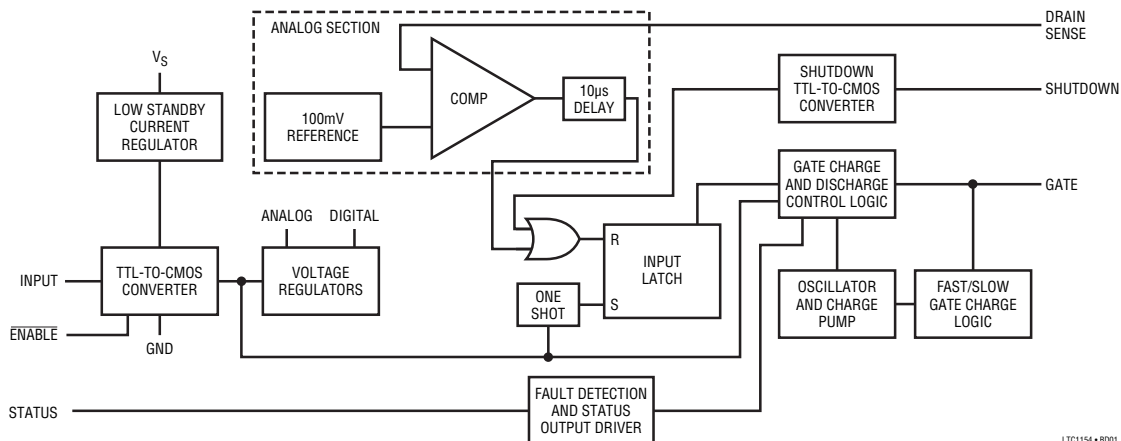

LTC1154 • 8001

1154fb

## TRUTH TABLE

INPUTS			OUTPUTS		SWITCH CONDITION
IN	$\overline{\text{EN}}$	SD	GATE	STATUS	
X	H	X	L	H	SWITCH OFF
L	X	X	L	H	SWITCH OFF
H	L	L	H	H	SWITCH ON
H	L	L	L	L	SWITCH LATCHED OFF (OVER CURRENT)
H	L	$\uparrow$	L	L	SWITCH LATCHED OFF (SHUTDOWN)

L = LOGIC LOW  
 H = LOGIC HIGH  
 X = IRRELEVANT

$\uparrow$  = EDGE TRIGGERED

The Truth Table demonstrates how the LTC1154 receives inputs and returns status information to the  $\mu\text{P}$ . The  $\overline{\text{ENABLE}}$  and input signal from the  $\mu\text{P}$  controls the switch in its normal operating mode, where the rise and fall time of the gate drive are controlled to limit EMI and RFI emissions. The shutdown and overcurrent detection circuitry however, switch the gate off at a much higher rate to limit the exposure of the MOSFET switch and the load to dangerous conditions. The status pin remains high as long as the switch is operating normally, and is driven low only when a fault condition is detected. Note that the shutdown pin is edge-sensitive and latches the output off even if the shutdown pin returns to a low state.

## OPERATION

The LTC1154 is a single micropower MOSFET driver with built-in protection, status feedback and gate charge pump. The LTC1154 consists of the following functional blocks:

### TTL and CMOS Compatible Inputs

The LTC1154 input and shutdown input have been designed to accommodate a wide range of logic families. Both input thresholds are set at about 1.3V with approximately 100mV of hysteresis.

A low standby current voltage regulator provides continuous bias for the TTL-to-CMOS converter. The TTL-to-CMOS converter output enables the rest of the circuitry. In this way the power consumption is kept to a minimum in the standby mode.

### ENABLE Input

The  $\overline{\text{ENABLE}}$  input is CMOS compatible and inhibits the input signal whenever it is held logic high. This input should be grounded when not in use.

### Internal Voltage Regulation

The output of the TTL-to-CMOS converter drives two regulated supplies which power the low voltage CMOS logic and analog blocks. The regulator outputs are isolated

from each other so that the noise generated by the charge pump logic is not coupled into the 100mV reference or the analog comparator.

### Gate Charge Pump

Gate drive for the MOSFET switch is produced by an adaptive charge pump circuit which generates a gate voltage substantially higher than the power supply voltage. The charge pump capacitors are included on chip and therefore no external components are required to generate the gate drive.

### Drain Current Sense

The LTC1154 is configured to sense the current flowing into the drain of the power MOSFET in a high side application. An internal 100mV reference is compared to the drop across a sense resistor (typically  $0.002\Omega$  to  $0.10\Omega$ ) in series with the drain lead. If the drop across this resistor exceeds the internal 100mV threshold, the input latch is reset and the gate is quickly discharged via a large N-channel transistor.

### Controlled Gate Rise and Fall Times

When the input is switched ON and OFF, the gate is charged by the internal charge pump and discharged in a controlled

## OPERATION

manner. The charge and discharge rates have been set to minimize RFI and EMI emissions in normal operation. If a short-circuit or current overload condition is encountered, the gate is discharged very quickly (typically a few microseconds) by a large N-channel transistor.

## APPLICATIONS INFORMATION

### MOSFET and Load Protection

The LTC1154 protects the power MOSFET switch by removing drive from the gate as soon as an overcurrent condition is detected. Resistive and inductive loads can be protected with no external time delay in series with the drain sense pin. Lamp loads, however, require that the overcurrent protection be delayed long enough to start the lamp but short enough to ensure the safety of the MOSFET.

### Resistive Loads

Loads that are primarily resistive should be protected with as short a delay as possible to minimize the amount of time that the MOSFET is subjected to an overload condition. The drain sense circuitry has a built-in delay of approximately 10 $\mu$ s to eliminate false triggering by power supply or load transient conditions. This delay is sufficient to “mask” short load current transients and the starting of a small capacitor (<1 $\mu$ F) in parallel with the load. The drain sense pin can therefore be connected directly to the drain current sense resistor as shown in Figure 1.

### Inductive Loads

Loads that are primarily inductive, such as relays, solenoids and stepper motor windings should be protected with as short a delay as possible to minimize the amount of time that the MOSFET is subjected to an overload condition. The built-in 10 $\mu$ s delay will ensure that the overcurrent protection is not false-triggered by a supply or load transient. No external delay components are required as shown in Figure 2.

Large inductive loads (>0.1mH) may require diodes connected directly across the inductor to safely divert the

### Status Output Driver

The status circuitry continuously monitors the fault detection logic. This open-drain output is driven low when the gate of the MOSFET is driven low by the protection circuitry. The status circuitry is reset along with the input latch when the input, or  $\overline{\text{ENABLE}}$  input, is cycled.

stored energy to ground. Many inductive loads have these diodes included. If not, a diode of the proper current rating should be connected across the load, as shown in Figure 2, to safely divert the stored energy.

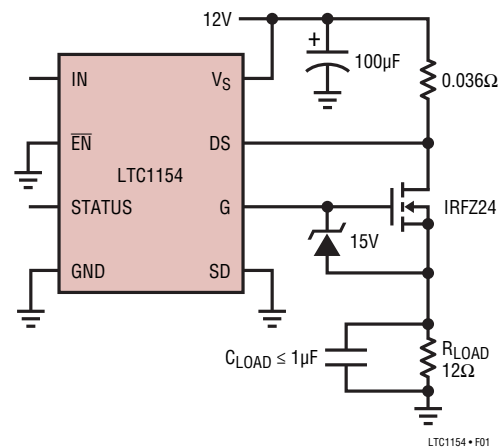

Figure 1. Protecting Resistive Loads

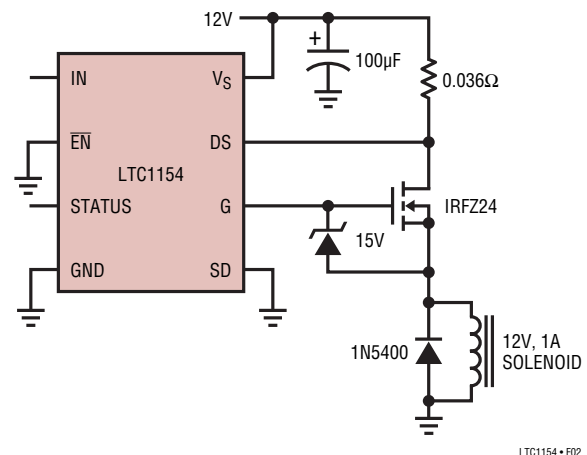

Figure 2. Protecting Inductive Loads



## APPLICATIONS INFORMATION

### Capacitive Loads

Large capacitive loads, such as complex electrical systems with large bypass capacitors, should be powered using the circuit shown in Figure 3. The gate drive to the power MOSFET is passed through an RC delay network, R1 and C1, which greatly reduces the turn-on ramp rate of the switch. And since the MOSFET source voltage follows the gate voltage, the load is powered smoothly and slowly from ground. This dramatically reduces the start-up current flowing into the supply capacitor(s) which, in turn, reduces supply transients and allows for slower activation of sensitive electrical loads. (Diode, D1, provides a direct path for the LTC1154 protection circuitry to quickly discharge the gate in the event of an overcurrent condition).

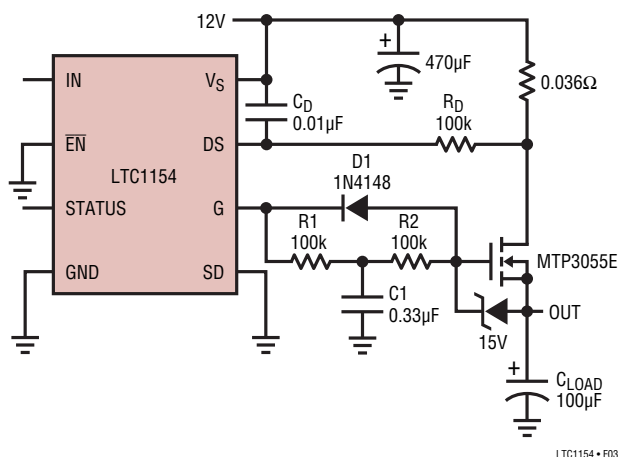

Figure 3. Powering Large Capacitive Loads

The RC network,  $R_D$  and  $C_D$ , in series with the drain sense input should be set to trip based on the expected characteristics of the load *after* start-up. With this circuit, it is possible to power a large capacitive load and still react quickly to an overcurrent condition. The ramp rate at the output of the switch as it lifts off ground is approximately:

$$dV/dt = (V_{GATE} - V_{TH}) / (R1 \cdot C1)$$

And therefore the current flowing into the capacitor during start-up is approximately:

$$I_{START-UP} = C_{LOAD} \cdot dV/dt$$

Using the values shown in Figure 3, the start-up current is less than 100mA and does not false-trigger the drain sense circuitry which is set at 2.7A with a 1ms delay.

### Lamp Loads

The inrush current created by a lamp during turn-on can be 10 to 20 times greater than the rated operating current. The circuit shown in Figure 4 shifts the current limit threshold up by a factor of 11:1 (to 30A) for 100ms when the bulb is first turned on. The current limit then drops down to 2.7A after the inrush current has subsided.

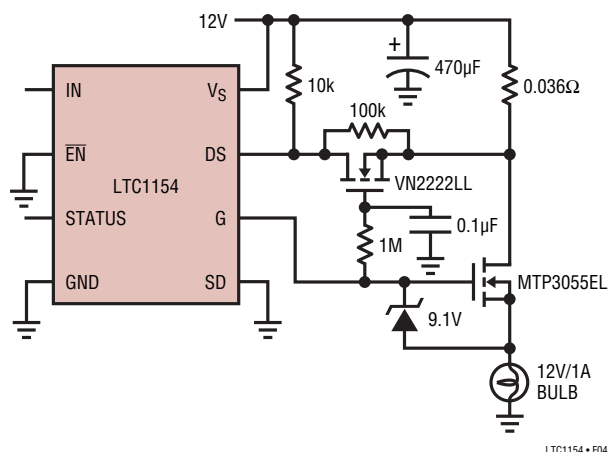

Figure 4. Lamp Driver with Delayed Protection

### Selecting $R_D$ and $C_D$

Figure 5 is a graph of normalized overcurrent shutdown time versus normalized MOSFET current. This graph is used to select the two delay components,  $R_D$  and  $C_D$ , which make up a simple RC delay between the drain sense resistor and the drain sense input.

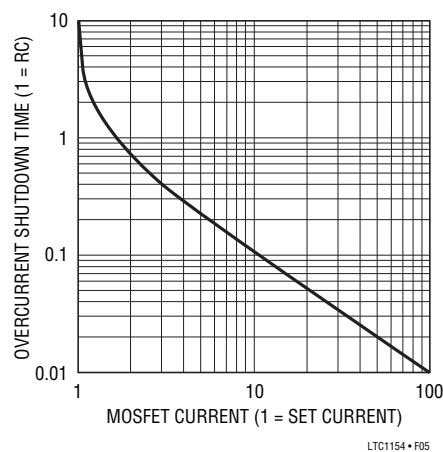

Figure 5. Overcurrent Shutdown Time vs MOSFET Current

## APPLICATIONS INFORMATION

The Y axis of the graph is normalized to one RC time constant. The X axis is normalized to the current. (The set current is defined as the current required to develop 100mV across the drain sense resistor).

Note that the shutdown time is shorter for increasing levels of MOSFET current. This ensures that the total energy dissipated by the MOSFET is always within the bounds established by the manufacturer for safe operation. (See MOSFET data sheet for further information).

### Using a Speed-Up Diode

To reduce the amount of time that the power MOSFET is in a short-circuit condition, “bypass” the delay resistor with a small signal diode as shown in Figure 6. The diode will engage when the drop across the drain sense resistor exceeds about 0.7V, providing a direct path to the sense pin and dramatically reducing the amount of time the MOSFET is in an overload condition. The drain sense resistor value

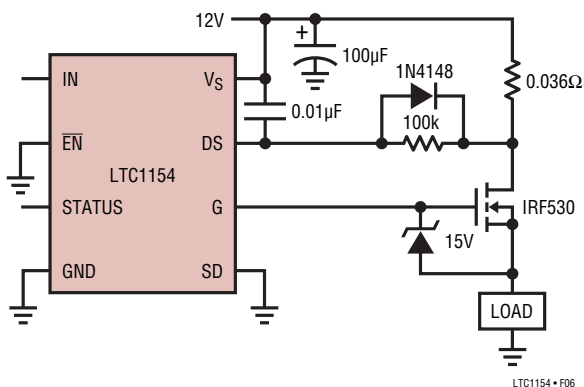

Figure 6. Using a Speed-Up Diode

is selected to limit the maximum DC current to 2.8A. The diode conducts when the drain current exceeds 20A and reduces the turn-off time to 15µs.

### Reverse Battery Protection

The LTC1154 can be protected against reverse battery conditions by connecting a resistor in series with the ground lead as shown in Figure 7. The resistor limits the supply current to less than 50mA with –12V applied.

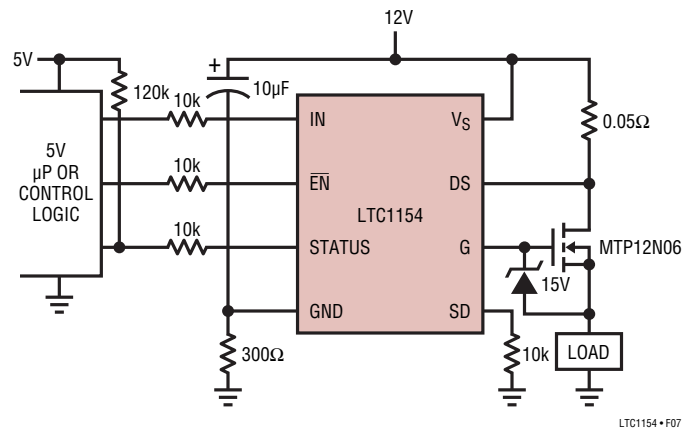

Figure 7. Reverse Battery Protection

Since the LTC1154 draws very little current while in normal operation, the drop across the ground resistor is minimal. The 5V µP (or control logic) is protected by the 10k resistors in series with the input and status pins.

### Current Limited Power Supplies

The LTC1154 requires at least 3.5V at the supply pin to ensure proper operation. It is therefore necessary that the supply to the LTC1154 be held higher than 3.5V at all times, even when the output of the switch is short circuited to ground. The output voltage of a current limited regulator may drop very quickly during short-circuit and pull the supply pin of the LTC1154 below 3.5V before the shutdown circuitry has had time to respond and remove drive from the gate of the power MOSFET. A supply filter should be

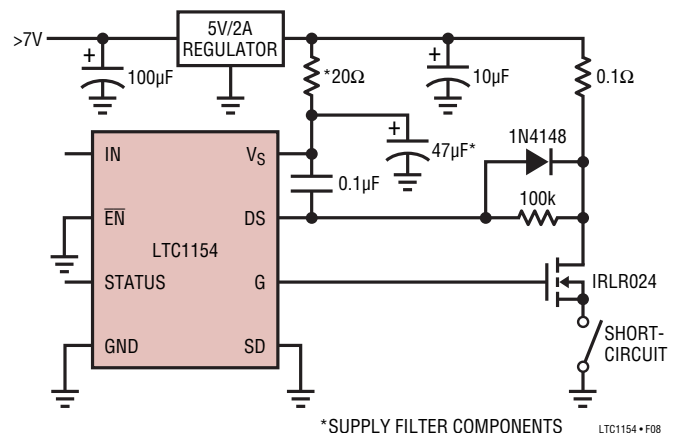

Figure 8. Supply Filter for Current Limited Supplies

## APPLICATIONS INFORMATION

added as shown in Figure 8 which holds the supply pin of the LTC1154 high long enough for the overcurrent shutdown circuitry to respond and fully discharge the gate.

Five volt linear regulators with small output capacitors are the most difficult to protect as they can “switch” from a voltage mode to a current limited mode very quickly. The large output capacitors on many switching regulators may

be able to hold the supply pin of the LTC1154 above 3.5V sufficiently long that this extra filtering is not required.

Because the LTC1154 is micropower in both the standby and ON state, the voltage drop across the supply filter is less than 2mV, and does not significantly alter the accuracy of the 100mV drain sense threshold voltage.

## TYPICAL APPLICATIONS

High Side Driver with Thermal Shutdown

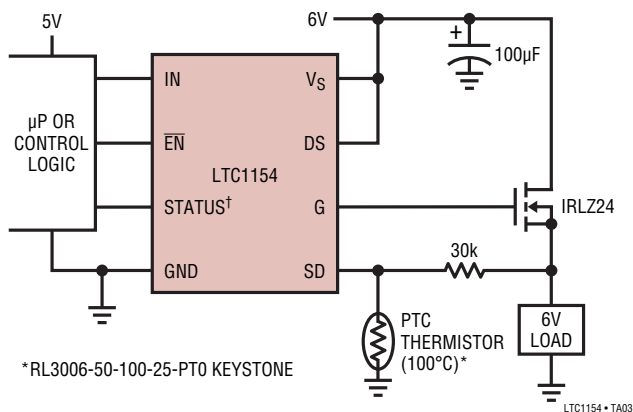

High Side Driver with Overvoltage Shutdown

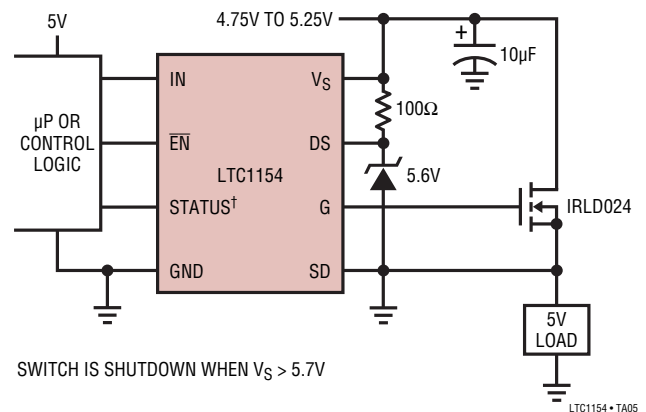

†A 51k pullup resistor should be connected between Status Output and 5V Logic Supply.

High Side Driver with Undervoltage Shutdown

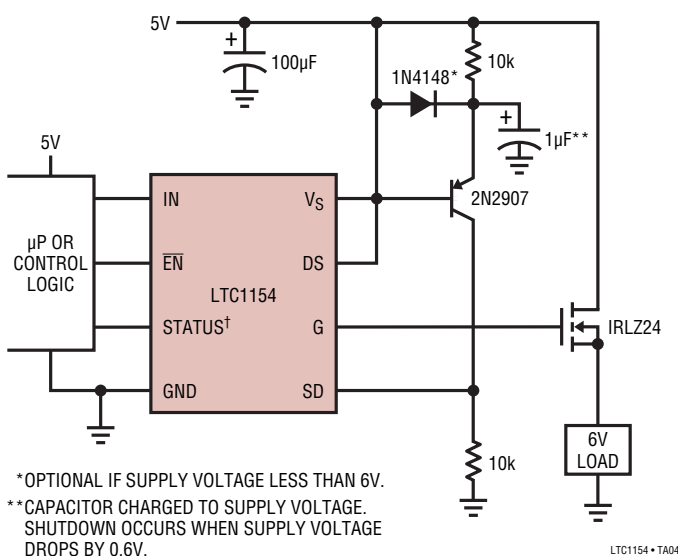

24V to 28V High Side Switch with Thermal Shutdown

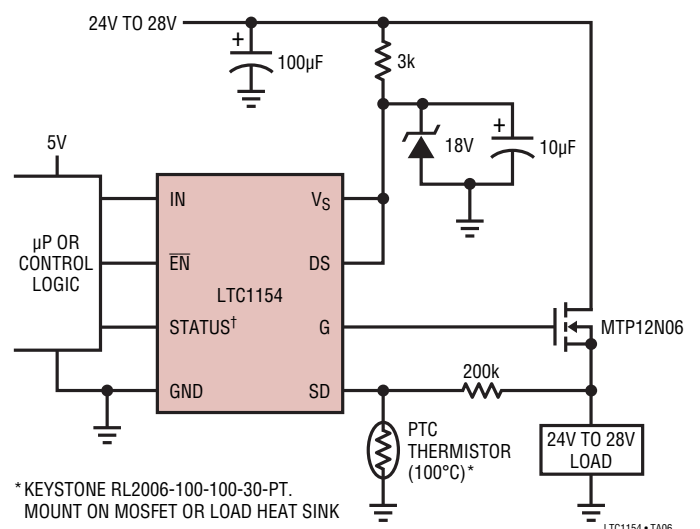

## TYPICAL APPLICATIONS

### 24V to 28V Switch with Bootstrapped Supply

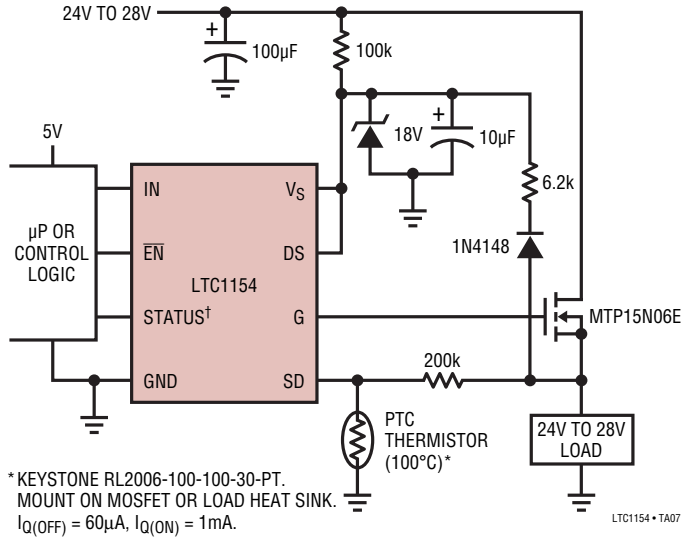

### High Side Relay Driver with Overcurrent Protection and Status Feedback

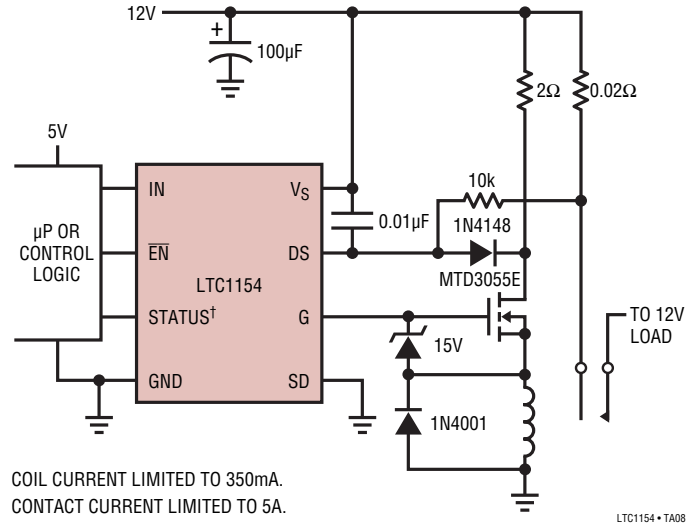

†A 51k pullup resistor should be connected between Status Output and 5V Logic Supply.

### “4-Cell-to-5V” Extremely Low Voltage Drop Regulator with Overcurrent Shutdown, Status Feedback, Ramped Turn-ON and 8µA Standby Current

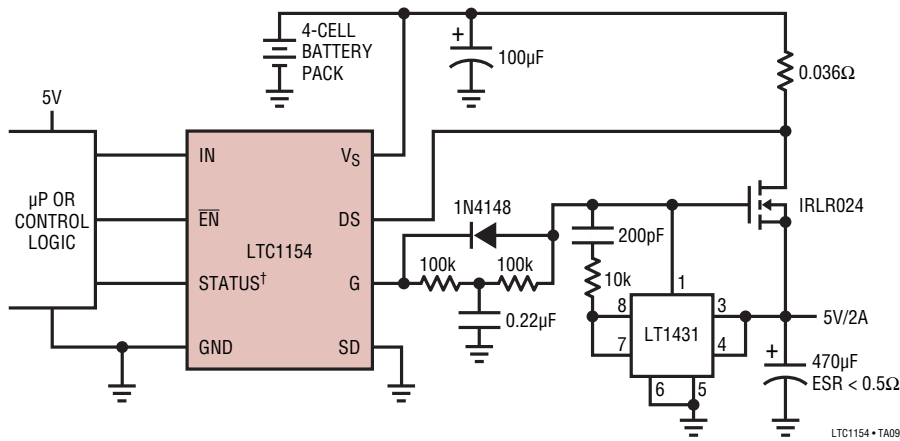

# TYPICAL APPLICATIONS

Bank Controlled High Side Switches with “Global” Thermal and Overvoltage Shutdown

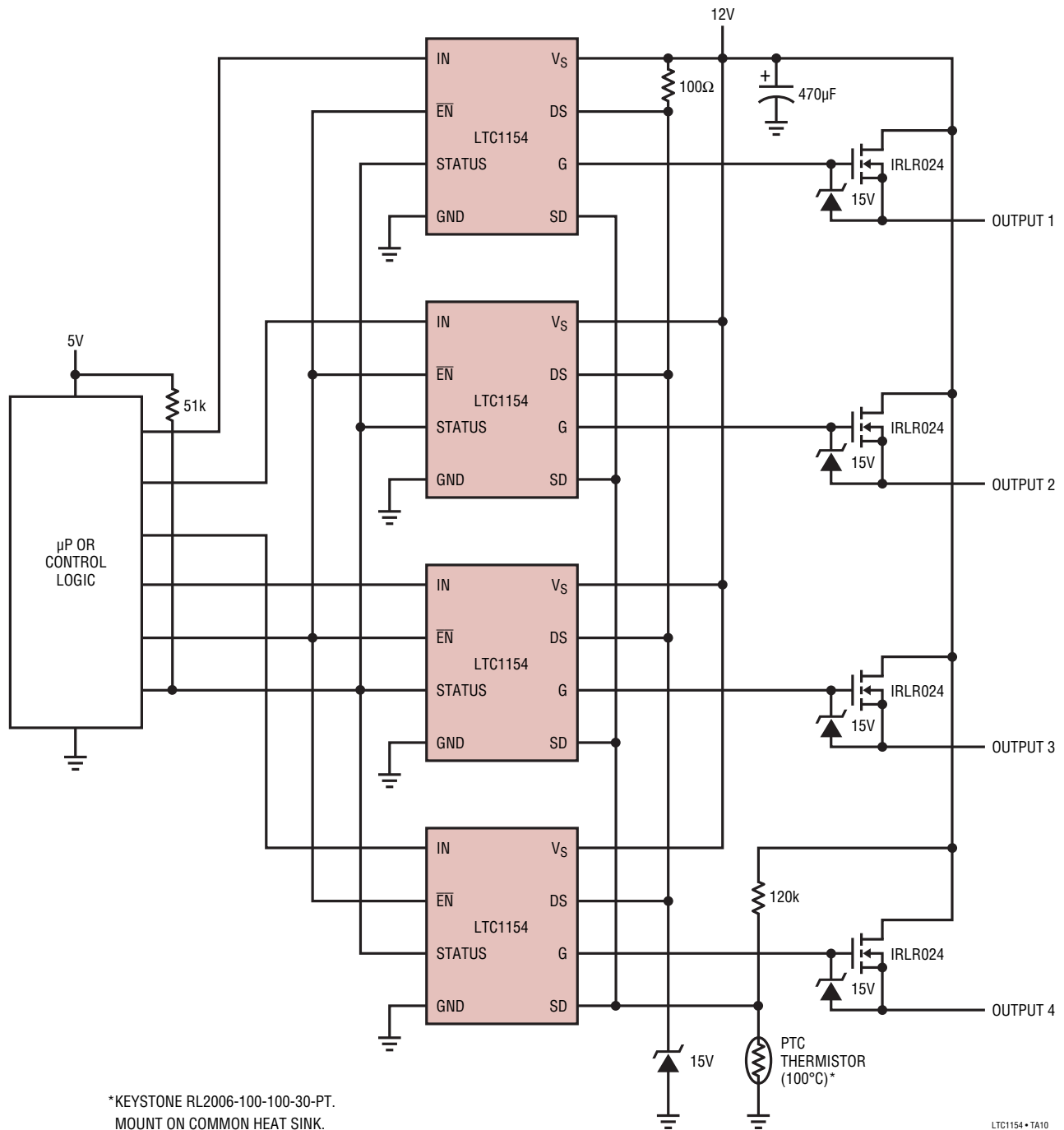

## TYPICAL APPLICATIONS

**12V Step-Up Regulator with Ultralow Standby Current, Overcurrent Protection and Status Feedback**

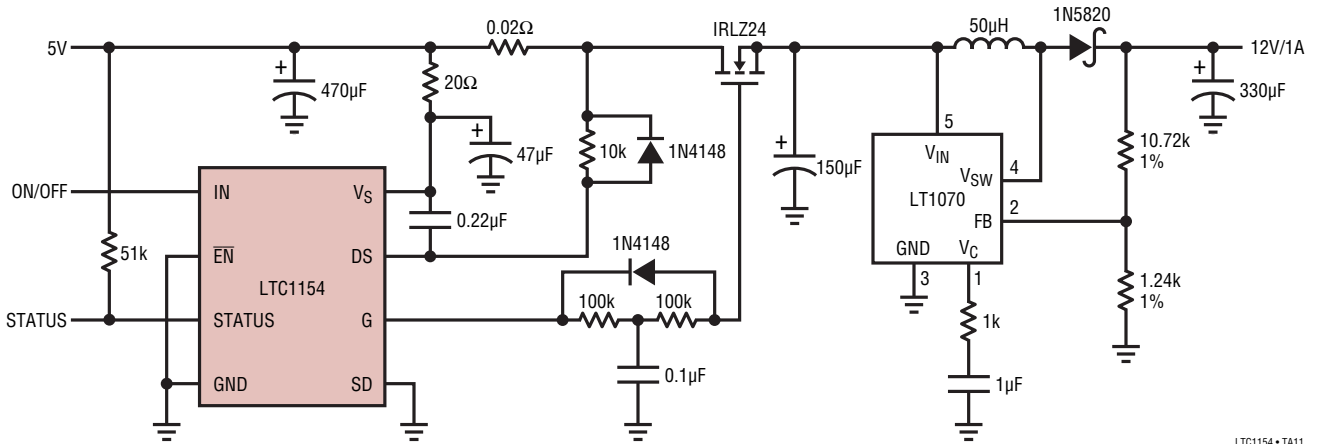

LTC1154 • TA11

**12V Step-Up Regulator with 1A Overcurrent Protection, Switch Status Feedback and Ramped Output**

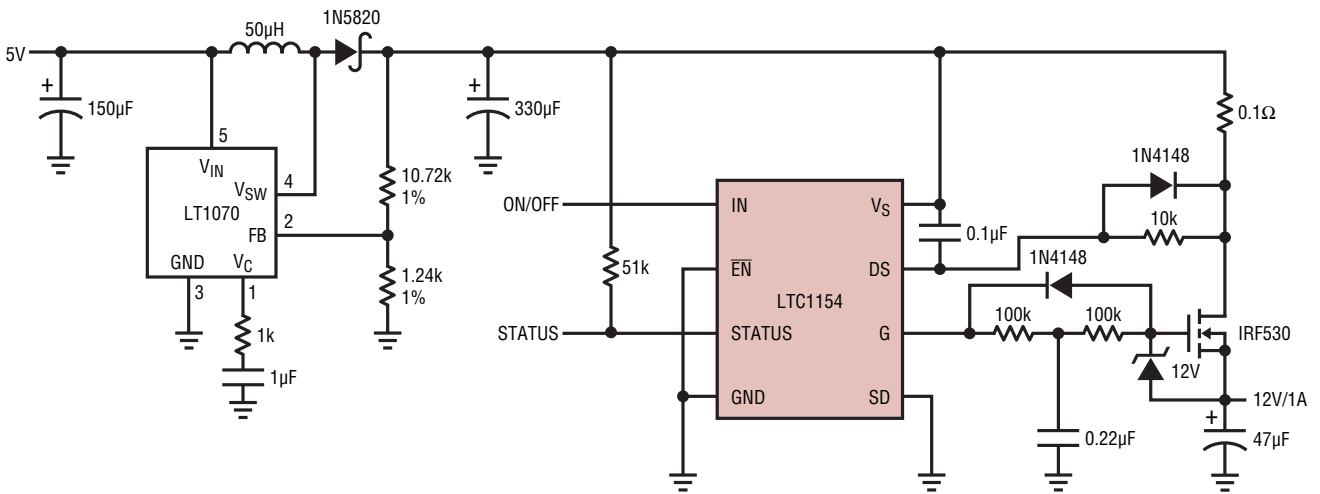

LTC1154 • TA12

# PACKAGE DESCRIPTION

**N8 Package**  
**8-Lead PDIP (Narrow .300 Inch)**  
 (Reference LTC DWG # 05-08-1510)

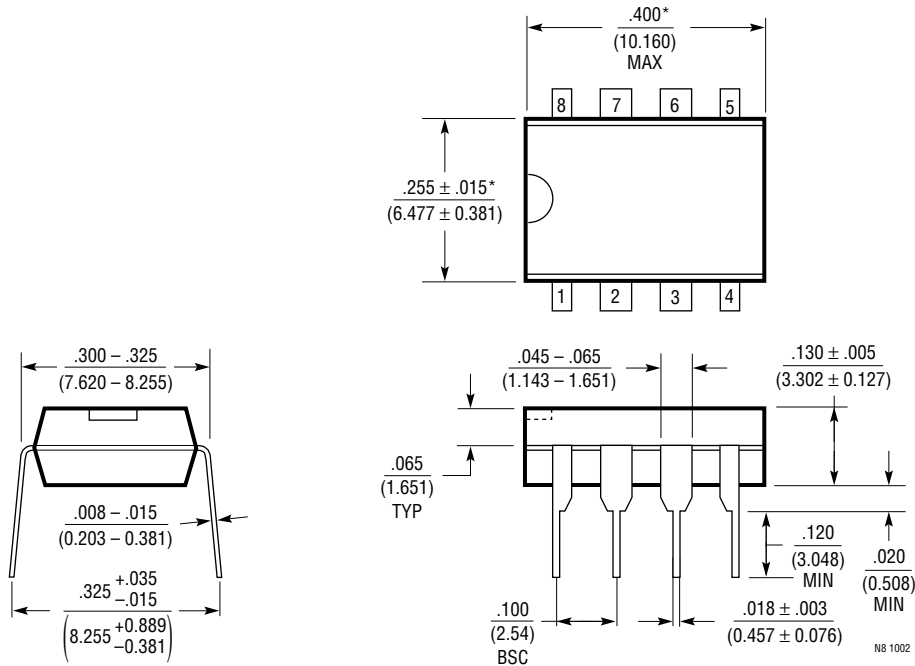

NOTE:  
 1. DIMENSIONS ARE  $\frac{\text{INCHES}}{\text{MILLIMETERS}}$   
 \*THESE DIMENSIONS DO NOT INCLUDE MOLD FLASH OR PROTRUSIONS.  
 MOLD FLASH OR PROTRUSIONS SHALL NOT EXCEED .010 INCH (0.254mm)

**PACKAGE DESCRIPTION**

**S8 Package**  
**8-Lead Plastic Small Outline (Narrow .150 Inch)**  
 (Reference LTC DWG # 05-08-1610)

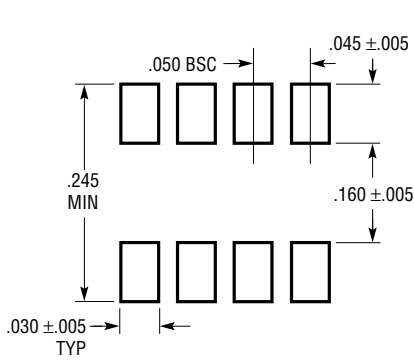

RECOMMENDED SOLDER PAD LAYOUT

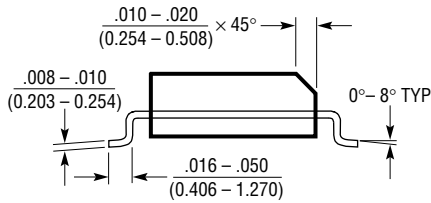

- NOTE:  
 1. DIMENSIONS IN  $\frac{\text{INCHES}}{\text{MILLIMETERS}}$   
 2. DRAWING NOT TO SCALE  
 3. THESE DIMENSIONS DO NOT INCLUDE MOLD FLASH OR PROTRUSIONS.  
 MOLD FLASH OR PROTRUSIONS SHALL NOT EXCEED .006" (0.15mm)

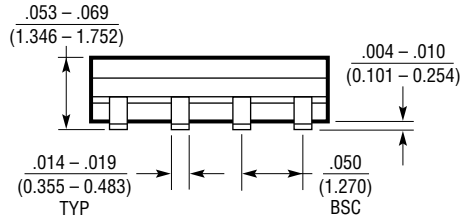
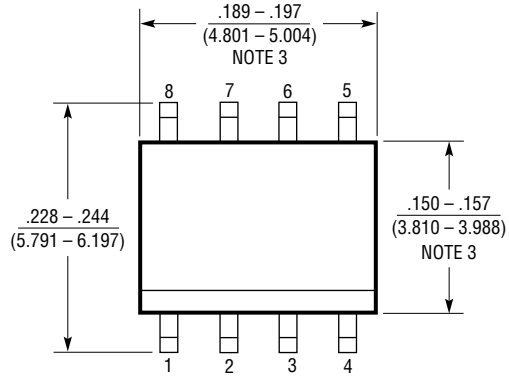

S08 0303



**REVISION HISTORY** (Revision history begins at Rev B)

REV	DATE	DESCRIPTION	PAGE NUMBER
B	4/11	Updated Graph TPC05	4
		Updated SCSI Termination Typical Application	18
		Updated Related Parts	18

## TYPICAL APPLICATIONS

### Auto-Reset High Side Switch with Overcurrent and Overcurrent Temperature Shutdown

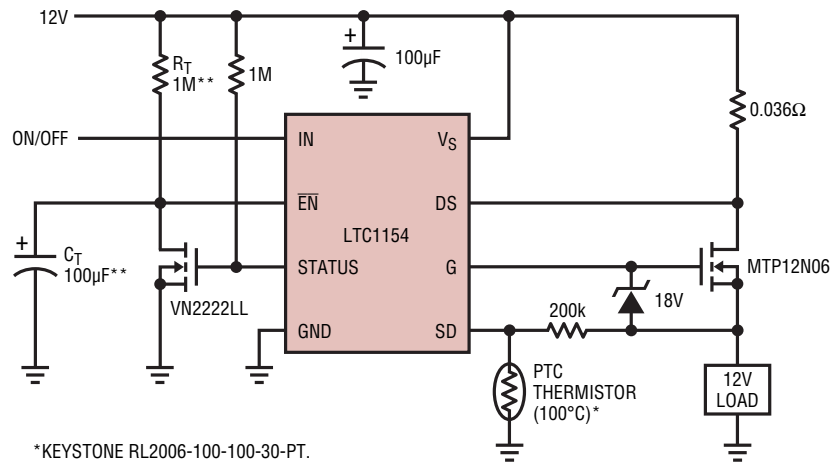

LTC1154 • TA13

### SCSI Termination Power Switch with 1A Overcurrent Shutdown, Auto-Reset and Load Soft-Start

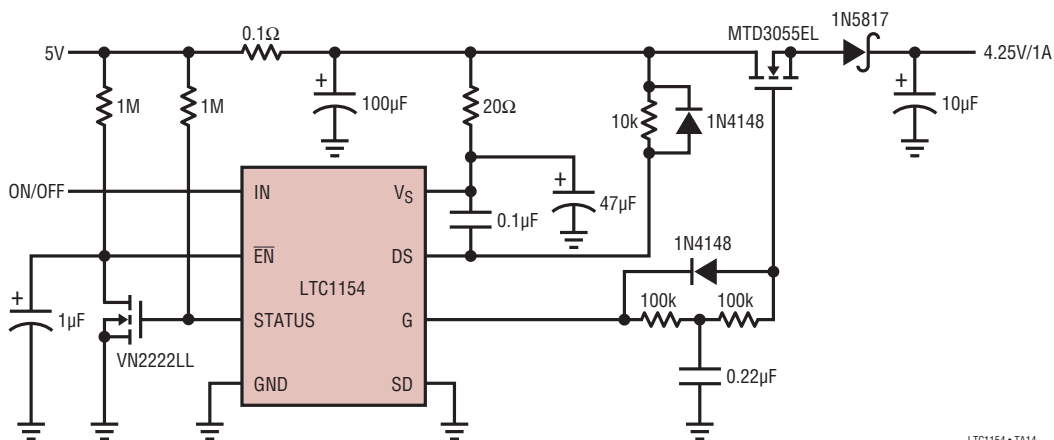

LTC1154 • TA14

## RELATED PARTS

PART NUMBER	DESCRIPTION	COMMENTS
LTC4440/LTC4440-5	High Speed, High Voltage High Side Gate Driver	Up to 80V Supply Voltage, $8V \leq V_{CC} \leq 15V$ , 2.4A Peak Pull-Up/1.5Ω Peak Pull-Down
LTC4441/LTC4441-1	N-Channel MOSFET Gate Driver	Up to 25V Supply Voltage, $5V \leq V_{CC} \leq 25V$ , 6A Peak Output Current
LT1910	Protected High Side Gate Driver	Up to 48V Supply Voltage, Short Circuit Protected
LTC4446	High Voltage Synchronous N-Channel MOSFET Driver without Shoot Thru Protection	Up to 100V Supply Voltage, $7.2V \leq V_{CC} \leq 13.5V$ , 3A Peak Pull-Up/0.55Ω Peak Pull-Down
LTC4444/LTC4444-5	High Voltage Synchronous N-Channel MOSFET Driver with Shoot Thru Protection	Up to 100V Supply Voltage, $4.5V/7.2V \leq V_{CC} \leq 13.5V$ , 3A Peak Pull-Up/0.55Ω Peak Pull-Down
LTC4442/LTC4449	High Speed Synchronous N-Channel MOSFET Driver	Up to 38V Supply Voltage, $4.5V/6V \leq V_{CC} \leq 9.5V$ , 3.2A Peak Pull-Up/4.5A Peak Pull-Down