

# Am29F160D



## *Data Sheet*

---

The following document contains information on Spansion memory products.

### **Continuity of Specifications**

There is no change to this data sheet as a result of offering the device as a Spansion product. Any changes that have been made are the result of normal data sheet improvement and are noted in the document revision summary.

### **For More Information**

Please contact your local sales office for additional information about Spansion memory solutions.

**This page left intentionally blank.**

# Am29F160D

16 Megabit (2 M x 8-Bit/1 M x 16-Bit)

CMOS 5.0 Volt-only, Boot Sector Flash Memory

## DISTINCTIVE CHARACTERISTICS

- **5.0 Volt single power supply operation**
  - Minimizes system-level power requirements
- **High performance**
  - Access times as fast as 70 ns
- **Manufactured on 0.23  $\mu$ m process technology**
- **CFI (Common Flash Interface) compliant**
  - Provides device-specific information to the system, allowing host software to easily reconfigure for different Flash devices
- **Ultra low power consumption (typical values at 5 MHz)**
  - 15 mA typical active read current
  - 35 mA typical erase/program current
  - 300 nA typical standby mode current
- **Flexible sector architecture**
  - One 16 Kbyte, two 8 Kbyte, one 32 Kbyte, and thirty-one 64 Kbyte sectors (byte mode)
  - One 8 Kword, two 4 Kword, one 16 Kword, and thirty-one 32 Kword sectors (word mode)
  - Supports full chip erase
  - Sector Protection features:
    - Hardware method of locking a sector to prevent program or erase operations within that sector
    - Sectors can be locked in-system or via programming equipment
    - Temporary Sector Unprotect feature allows code changes in previously locked sectors
- **Top boot or bottom boot configurations available**
- **Minimum 1,000,000 write cycle guarantee per sector**
- **20-year data retention at 125°C**
  - Reliable operation for the life of the system
- **Package options**
  - 48-pin TSOP
- **Compatible with JEDEC standards**
  - Pinout and software compatible with single-power supply Flash
  - Superior inadvertent write protection
- **Embedded Algorithms**
  - Embedded Erase algorithm automatically preprograms and erases the entire chip or any combination of designated sectors
  - Embedded Program algorithm automatically writes and verifies data at specified addresses
- **Erase Suspend/Erase Resume**
  - Suspends an erase operation to read data from, or program data to, a sector that is not being erased, then resumes the erase operation
- **Data# Polling and toggle bits**
  - Provides a software method of detecting program or erase operation completion
- **Unlock Bypass Program command**
  - Reduces overall programming time when issuing multiple program command sequences
- **Ready/Busy# pin (RY/BY#)**
  - Provides a hardware method of detecting program or erase cycle completion
- **Hardware reset pin (RESET#)**
  - Hardware method to reset the device for reading array data
- **WP# input pin**
  - At  $V_{IL}$ , protects the 16 Kbyte boot sector from erasure regardless of sector protect/unprotect status
  - At  $V_{IH}$ , allows removal of boot sector protection
- **Program and Erase Performance**
  - Sector erase time: 1 s typical for each 64 Kbyte sector
  - Byte program time: 7  $\mu$ s typical

## GENERAL DESCRIPTION

The Am29F160D is a 16 Mbit, 5.0 Volt-only Flash memory device organized as 2,097,152 bytes or 1,048,576 words. Data appears on DQ0-DQ7 or DQ0-DQ15 depending on the data width selected. The device is designed to be programmed in-system with the standard system 5.0 volt  $V_{CC}$  supply. A 12.0 volt  $V_{PP}$  is not required for program or erase operations. The device can also be programmed in standard EPROM programmers.

The device offers access times of 70 and 90 ns, allowing high speed microprocessors to operate without wait states. The device is offered in a 48-pin TSOP package. To eliminate bus contention each device has separate chip enable (CE#), write enable (WE#) and output enable (OE#) controls.

Each device requires only a **single 5.0 volt power supply** for both read and write functions. Internally generated and regulated voltages are provided for the program and erase operations.

The device is entirely command set compatible with the **JEDEC single-power-supply Flash standard**. Commands are written to the command register using standard microprocessor write timing. Register contents serve as inputs to an internal state-machine that controls the erase and programming circuitry. Write cycles also internally latch addresses and data needed for the programming and erase operations. Reading data out of the device is similar to reading from other Flash or EPROM devices.

Device programming occurs by executing the program command sequence. This initiates the **Embedded Program** algorithm—an internal algorithm that automatically times the program pulse widths and verifies proper cell margin. The **Unlock Bypass mode** facilitates faster programming times by requiring only two write cycles to program data instead of four.

Device erasure occurs by executing the erase command sequence. This initiates the **Embedded Erase algorithm**—an internal algorithm that automatically preprograms the array (if it is not already programmed) before executing the erase operation. During erase, the device automatically times the erase pulse widths and verifies proper cell margin.

The host system can detect whether a program or erase operation is complete by observing the RY/BY# pin, by reading the DQ7 (Data# Polling), or DQ6 (toggle) **status bits**. After a program or erase cycle is completed, the device is ready to read array data or accept another command.

The **sector erase architecture** allows memory sectors to be erased and reprogrammed without affecting the data contents of other sectors. The device is fully erased when shipped from the factory.

**Hardware data protection** measures include a low VCC detector that automatically inhibits write operations during power transitions. The **hardware sector protection** feature disables both program and erase operations in any combination of sectors of memory. This can be achieved in-system or via programming equipment.

The **Write Protect (WP#)** feature protects the 16 Kbyte boot sector from erasure, by asserting a logic low on the WP# pin, whether or not the sector had been previously protected.

The **Erase Suspend/Erase Resume** feature enables the user to put erase on hold for any period of time to read data from, or program data to, any sector that is not selected for erasure. True background erase can thus be achieved.

The **hardware RESET# pin** terminates any operation in progress and resets the internal state machine to reading array data. The RESET# pin may be tied to the system reset circuitry. A system reset would thus also reset the device, enabling the system microprocessor to read boot-up firmware from the Flash memory device.

The device offers a **standby mode** as a power-saving feature. Once the system places the device into the standby mode power consumption is greatly reduced.

AMD's Flash technology combines years of Flash memory manufacturing experience to produce the highest levels of quality, reliability and cost effectiveness. The device electrically erases all bits within a sector simultaneously via Fowler-Nordheim tunnelling. The data is programmed using hot electron injection.

**TABLE OF CONTENTS**

<b>Product Selector Guide</b> . . . . .	<b>4</b>	DQ7: Data# Polling . . . . .	<b>23</b>
<b>Block Diagram</b> . . . . .	<b>4</b>	Figure 5. Data# Polling Algorithm . . . . .	<b>23</b>
<b>Connection Diagrams</b> . . . . .	<b>5</b>	RY/BY#: Ready/Busy# . . . . .	<b>24</b>
<b>Pin Configuration</b> . . . . .	<b>6</b>	DQ6: Toggle Bit I . . . . .	<b>24</b>
<b>Logic Symbol</b> . . . . .	<b>6</b>	DQ2: Toggle Bit II . . . . .	<b>24</b>
<b>Ordering Information</b> . . . . .	<b>7</b>	Reading Toggle Bits DQ6/DQ2 . . . . .	<b>24</b>
<b>Device Bus Operations</b> . . . . .	<b>8</b>	DQ5: Exceeded Timing Limits . . . . .	<b>25</b>
Table 1. Am29F160D Device Bus Operations . . . . .	<b>8</b>	DQ3: Sector Erase Timer . . . . .	<b>25</b>
Word/Byte Configuration . . . . .	<b>8</b>	Figure 6. Toggle Bit Algorithm . . . . .	<b>25</b>
Requirements for Reading Array Data . . . . .	<b>8</b>	Table 10. Write Operation Status . . . . .	<b>26</b>
Writing Commands/Command Sequences . . . . .	<b>9</b>	<b>Absolute Maximum Ratings</b> . . . . .	<b>27</b>
Program and Erase Operation Status . . . . .	<b>9</b>	Figure 7. Maximum Negative Overshoot Waveform . . . . .	<b>27</b>
Standby Mode . . . . .	<b>9</b>	Figure 8. Maximum Positive Overshoot Waveform . . . . .	<b>27</b>
Automatic Sleep Mode . . . . .	<b>9</b>	<b>Operating Ranges</b> . . . . .	<b>27</b>
RESET#: Hardware Reset Pin . . . . .	<b>9</b>	<b>DC Characteristics</b> . . . . .	<b>28</b>
Output Disable Mode . . . . .	<b>9</b>	TTL/NMOS Compatible . . . . .	<b>28</b>
Table 2. Am29F160DT Sector Address Table (Top Boot) . . . . .	<b>10</b>	CMOS Compatible . . . . .	<b>29</b>
Table 3. Am29F160DB Sector Address Table (Bottom Boot) . . . . .	<b>11</b>	<b>Test Conditions</b> . . . . .	<b>30</b>
Autoselect Mode . . . . .	<b>12</b>	Figure 9. Test Setup . . . . .	<b>30</b>
Table 4. Am29F160D Autoselect Codes (High Voltage Method) . . . . .	<b>12</b>	Table 11. Test Specifications . . . . .	<b>30</b>
Sector Protection/Unprotection . . . . .	<b>12</b>	<b>Key to Switching Waveforms</b> . . . . .	<b>30</b>
Write Protect (WP#) . . . . .	<b>13</b>	<b>AC Characteristics</b> . . . . .	<b>31</b>
Temporary Sector Unprotect . . . . .	<b>13</b>	Figure 10. Read Operations Timings . . . . .	<b>31</b>
Figure 1. Temporary Sector Unprotect Operation . . . . .	<b>13</b>	Figure 11. RESET# Timings . . . . .	<b>32</b>
In-System Sector Protect/Unprotect Algorithms . . . . .	<b>14</b>	Figure 12. BYTE# Timings for Read Operations . . . . .	<b>33</b>
<b>Common Flash Memory Interface (CFI)</b> . . . . .	<b>15</b>	Figure 13. BYTE# Timings for Write Operations . . . . .	<b>33</b>
Table 5. CFI Query Identification String . . . . .	<b>15</b>	Figure 14. Program Operation Timings . . . . .	<b>35</b>
Table 6. System Interface String . . . . .	<b>16</b>	Figure 15. Chip/Sector Erase Operation Timings . . . . .	<b>36</b>
Table 7. Device Geometry Definition . . . . .	<b>16</b>	Figure 16. Data# Polling Timings (During Embedded Algorithms) . . . . .	<b>37</b>
Table 8. Primary Vendor-Specific Extended Query . . . . .	<b>17</b>	Figure 17. Toggle Bit Timings (During Embedded Algorithms) . . . . .	<b>37</b>
Hardware Data Protection . . . . .	<b>18</b>	Figure 18. DQ2 vs. DQ6 . . . . .	<b>38</b>
Reading Array Data . . . . .	<b>18</b>	Figure 19. Temporary Sector Unprotect Timing Diagram . . . . .	<b>38</b>
Reset Command . . . . .	<b>18</b>	Figure 20. Sector Protect/Unprotect Timing Diagram . . . . .	<b>39</b>
Autoselect Command Sequence . . . . .	<b>19</b>	Figure 21. Alternate CE# Controlled Write Operation Timings . . . . .	<b>41</b>
Word/Byte Program Command Sequence . . . . .	<b>19</b>	<b>Erase and Programming Performance</b> . . . . .	<b>42</b>
Figure 3. Program Operation . . . . .	<b>20</b>	<b>Latchup Characteristics</b> . . . . .	<b>42</b>
Chip Erase Command Sequence . . . . .	<b>20</b>	<b>TSOP and SO Pin Capacitance</b> . . . . .	<b>42</b>
Sector Erase Command Sequence . . . . .	<b>20</b>	<b>Data Retention</b> . . . . .	<b>42</b>
Erase Suspend/Erase Resume Commands . . . . .	<b>21</b>	<b>Physical Dimensions</b> . . . . .	<b>43</b>
Figure 4. Erase Operation . . . . .	<b>21</b>	<b>Revision Summary</b> . . . . .	<b>44</b>
Command Definitions . . . . .	<b>22</b>		
Table 9. Am29F160D Command Definitions . . . . .	<b>22</b>		
<b>Write Operation Status</b> . . . . .	<b>23</b>		

PRODUCT SELECTOR GUIDE

Family Part Number		Am29F160D		
Speed Option	$V_{CC} = 5.0\text{ V} \pm 5\%$	75		
	$V_{CC} = 5.0\text{ V} \pm 10\%$		70	90
Max access time, ns ( $t_{ACC}$ )		70	70	90
Max CE# access time, ns ( $t_{CE}$ )		70	70	90
Max OE# access time, ns ( $t_{OE}$ )		30	30	35

**Note:**  
See "AC Characteristics" for full specifications.

BLOCK DIAGRAM

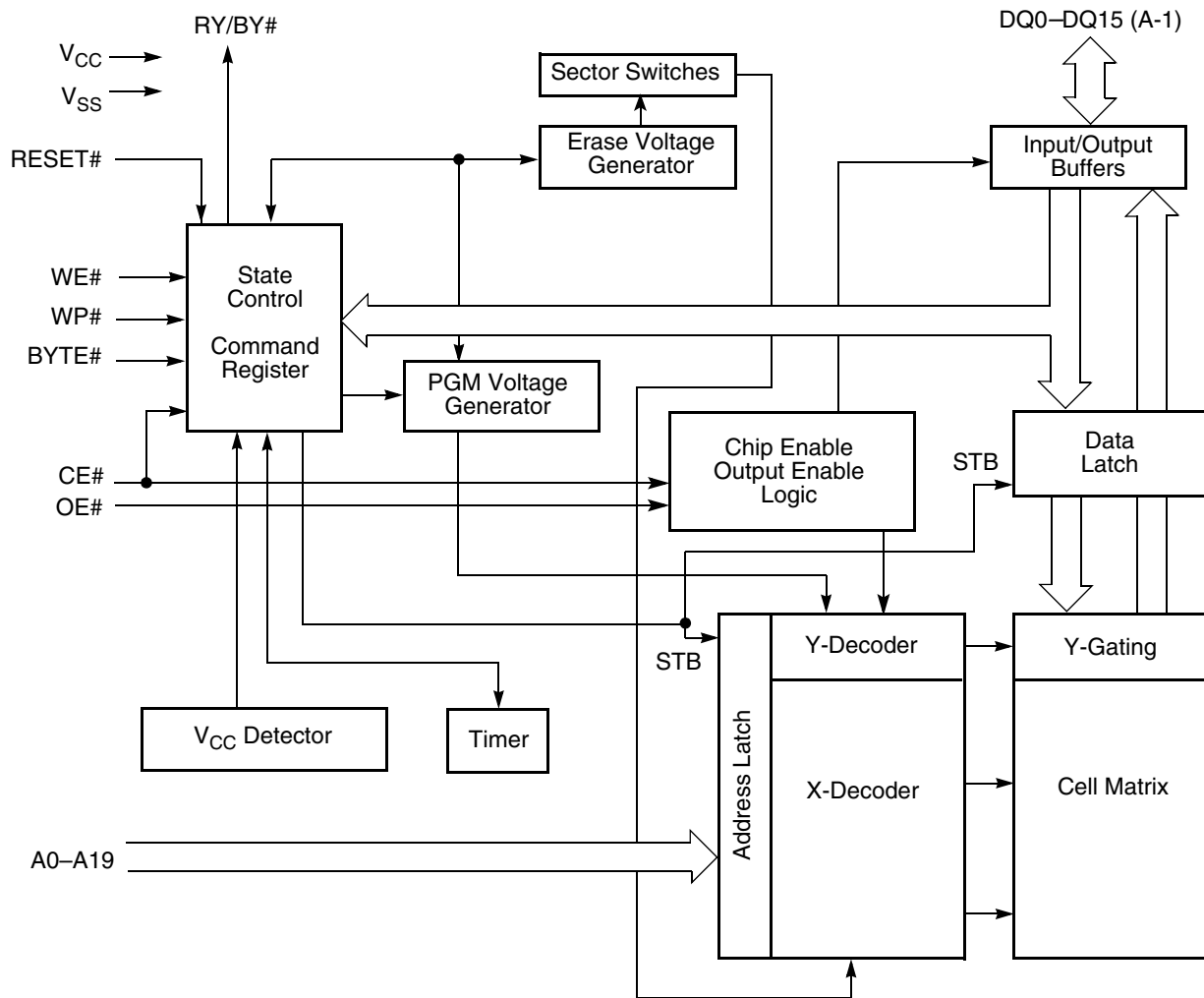

CONNECTION DIAGRAMS

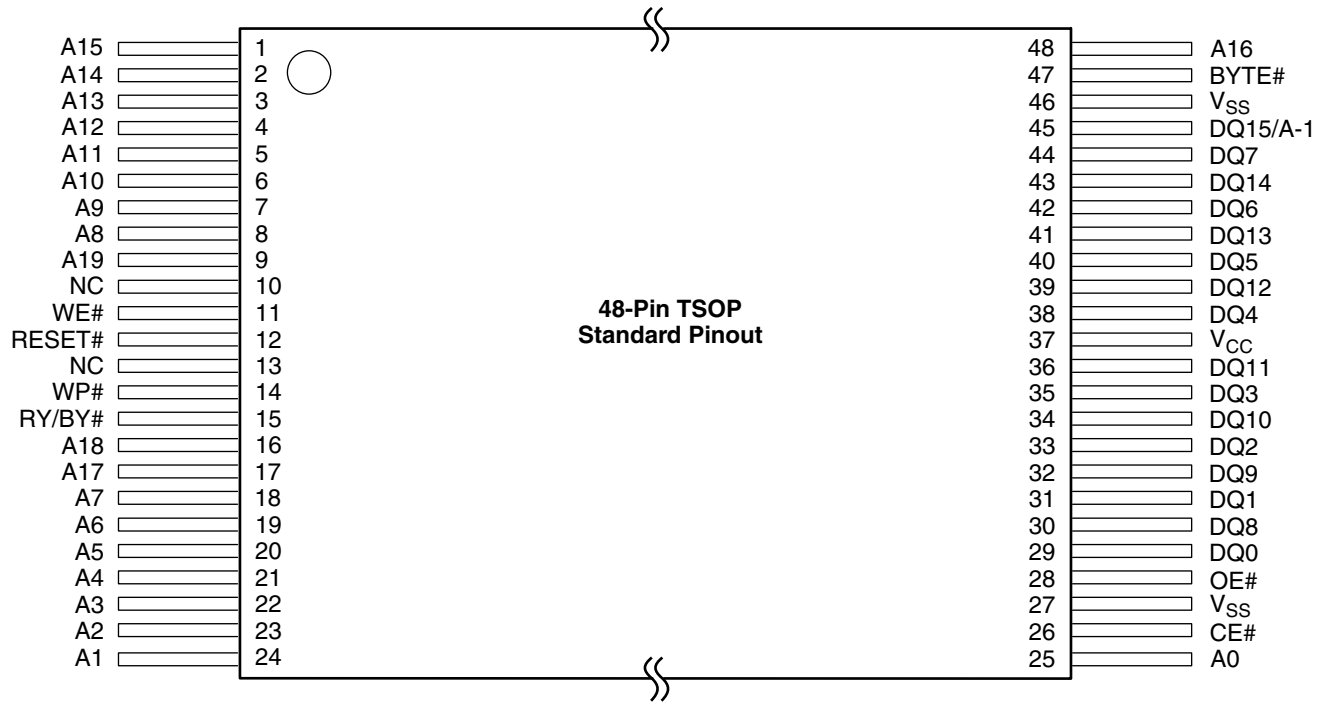

**PIN CONFIGURATION**

- A0–A19 = 20 address inputs
- DQ0–DQ14 = 15 data inputs/outputs
- DQ15/A-1 = DQ15 (data input/output, word mode),  
A-1 (LSB address input, byte mode)
- BYTE# = Select input for 8-bit or 16-bit mode
- CE# = Chip Enable input
- OE# = Output Enable input
- WE# = Write Enable input
- WP# = Write Protect input
- RESET# = Hardware reset input
- RY/BY# = Ready/Busy# output
- V<sub>CC</sub> = +5.0 V single power supply  
(see Product Selector Guide for  
device speed ratings and voltage  
supply tolerances)
- V<sub>SS</sub> = Device ground
- NC = Pin not connected internally

**LOGIC SYMBOL**

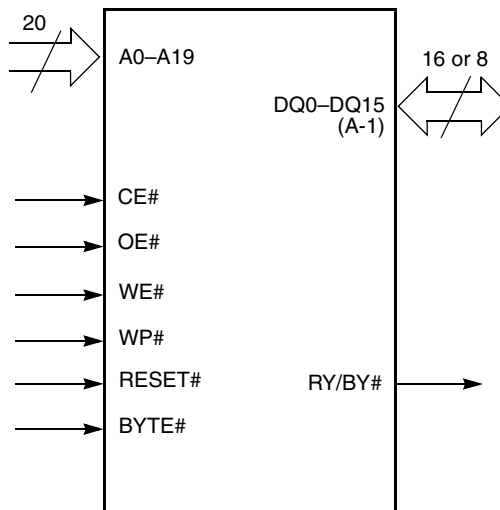



## ORDERING INFORMATION

### Standard Products

AMD standard products are available in several packages and operating ranges. The order number (Valid Combination) is formed by a combination of the elements below.

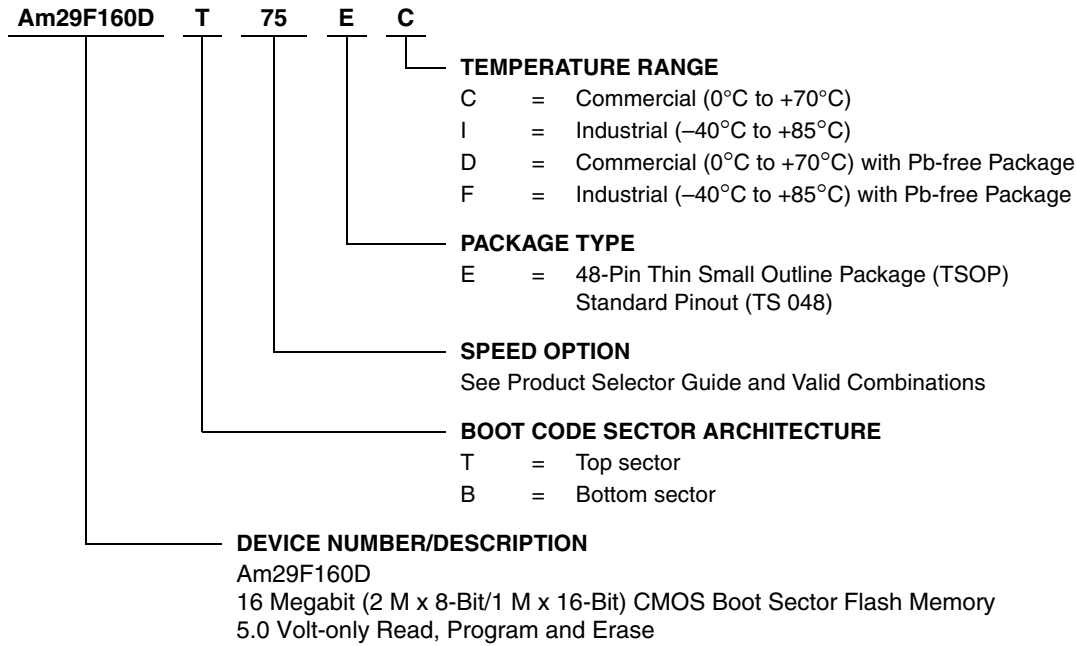

Valid Combinations		Speed (ns)	Voltage Range
Order Number			
AM29F160DT75, AM29F160DB75	EC, EI, ED, EF	70	5.0 V ± 5%
AM29F160DT70, AM29F160DB70	EC, EI, ED, EF	70	5.0 V ± 10%
AM29F160DT90, AM29F160DB90	EC, EI, ED, EF	90	

#### Valid Combinations

Valid Combinations list configurations planned to be supported in volume for this device. Consult the local AMD sales office to confirm availability of specific valid combinations and to check on newly released combinations.

## DEVICE BUS OPERATIONS

This section describes the requirements and use of the device bus operations, which are initiated through the internal command register. The command register itself does not occupy any addressable memory location. The register is composed of latches that store the commands, along with the address and data information needed to execute the command. The contents of

the register serve as inputs to the internal state machine. The state machine outputs dictate the function of the device. The appropriate device bus operations table lists the inputs and control levels required, and the resulting output. The following subsections describe each of these operations in further detail.

**Table 1. Am29F160D Device Bus Operations**

Operation	CE#	OE#	WE#	WP#	RESET#	Addresses (Note 1)	DQ0– DQ7	DQ8–DQ15	
								BYTE# = V <sub>IH</sub>	BYTE# = V <sub>IL</sub>
Read	L	L	H	X	H	A <sub>IN</sub>	D <sub>OUT</sub>	D <sub>OUT</sub>	DQ8–DQ14 = High-Z, DQ15 = A-1
Write	L	H	L	(Note 3)	H	A <sub>IN</sub>	D <sub>IN</sub>	D <sub>IN</sub>	
Standby	V <sub>CC</sub> ± 0.5 V	X	X	(Note 4)	V <sub>CC</sub> ± 0.5 V	X	High-Z	High-Z	High-Z
Output Disable	L	H	H	X	H	X	High-Z	High-Z	High-Z
Reset	X	X	X	X	L	X	High-Z	High-Z	High-Z
Sector Protect (Note 2)	L	H	L	X	V <sub>ID</sub>	Sector Address, A6 = L, A1 = H, A0 = L	D <sub>IN</sub>	X	X
Sector Unprotect (Note 2)	L	H	L	X	V <sub>ID</sub>	Sector Address, A6 = H, A1 = H, A0 = L	D <sub>IN</sub>	X	X
Temporary Sector Unprotect	X	X	X	(Note 3)	V <sub>ID</sub>	A <sub>IN</sub>	D <sub>IN</sub>	D <sub>IN</sub>	High-Z

### Legend:

L = Logic Low = V<sub>IL</sub>, H = Logic High = V<sub>IH</sub>, V<sub>ID</sub> = 12.0 ± 0.5 V, X = Don't Care, A<sub>IN</sub> = Address In, D<sub>IN</sub> = Data In, D<sub>OUT</sub> = Data Out

### Notes:

- Addresses are A19:A0 in word mode (BYTE# = V<sub>IH</sub>), A19:A-1 in byte mode (BYTE# = V<sub>IL</sub>).
- The sector protect and sector unprotect functions may also be implemented via programming equipment. See the "Sector Protection/Unprotection" section.
- The 16 Kbyte boot sector is protected from erasure when WP# = V<sub>IL</sub>.
- In CMOS mode, WP# must be at V<sub>CC</sub>±0.5 V or left floating.

## Word/Byte Configuration

The BYTE# pin controls whether the device data I/O pins DQ15–DQ0 operate in the byte or word configuration. If the BYTE# pin is set at logic '1', the device is in word configuration, DQ15–DQ0 are active and controlled by CE# and OE#.

If the BYTE# pin is set at logic '0', the device is in byte configuration, and only data I/O pins DQ0–DQ7 are active and controlled by CE# and OE#. The data I/O pins DQ8–DQ14 are tri-stated, and the DQ15 pin is used as an input for the LSB (A-1) address function.

## Requirements for Reading Array Data

To read array data from the outputs, the system must drive the CE# and OE# pins to V<sub>IL</sub>. CE# is the power control and selects the device. OE# is the output control

and gates array data to the output pins. WE# should remain at V<sub>IH</sub>.

The internal state machine is set for reading array data upon device power-up, or after a hardware reset. This ensures that no spurious alteration of the memory content occurs during the power transition. No command is necessary in this mode to obtain array data. Standard microprocessor read cycles that assert valid addresses on the device address inputs produce valid data on the device data outputs. The device remains enabled for read access until the command register contents are altered.

See [Reading Array Data, on page 18](#) for more information. Refer to the AC Read Operations table for timing specifications and to the Read Operations Timings diagram for the timing waveforms. I<sub>CC1</sub> in the DC Char-

acteristics table represents the active current specification for reading array data.

## Writing Commands/Command Sequences

To write a command or command sequence (which includes programming data to the device and erasing sectors of memory), the system must drive WE# and CE# to  $V_{IL}$ , and OE# to  $V_{IH}$ .

An erase operation can erase one sector, multiple sectors, or the entire device. The Sector Address Tables indicate the address space that each sector occupies. A “sector address” consists of the address bits required to uniquely select a sector. See the [Command Definitions, on page 18](#) section for details on erasing a sector or the entire chip, or suspending/resuming the erase operation.

After the system writes the autoselect command sequence, the device enters the autoselect mode. The system can then read autoselect codes from the internal register (which is separate from the memory array) on DQ7–DQ0. Standard read cycle timings apply in this mode. Refer to the [Autoselect Mode, on page 12](#) and [Autoselect Command Sequence, on page 19](#) sections for more information.

$I_{CC2}$  in the DC Characteristics table represents the active current specification for the write mode. The “AC Characteristics” section contains timing specification tables and timing diagrams for write operations.

## Program and Erase Operation Status

During an erase or program operation, the system may check the status of the operation by reading the status bits on DQ7–DQ0. Standard read cycle timings and  $I_{CC}$  read specifications apply. Refer to [Write Operation Status, on page 23](#) for more information, and to each AC Characteristics section for timing diagrams.

## Standby Mode

When the system is not reading or writing to the device, it can place the device in the standby mode. In this mode, current consumption is greatly reduced, and the outputs are placed in the high impedance state, independent of the OE# input.

The device enters the CMOS standby mode when the CE# and RESET# are held at  $V_{CC} \pm 0.5$  V. (Note that this is a more restricted voltage range than  $V_{IH}$ .) WP# must also either be held at  $V_{CC} \pm 0.5$  V or left floating. The device enters the TTL standby mode when CE# and RESET# pins are both held at  $V_{IH}$ . The device requires standard access time ( $t_{CE}$ ) for read access when the device is in either of these standby modes, before it is ready to read data.

The device also enters the standby mode when the RESET# pin is driven low. Refer to the next section, [RESET#: Hardware Reset Pin, on page 9](#).

If the device is deselected during erasure or programming, the device draws active current until the operation is completed.

In the DC Characteristics tables,  $I_{CC3}$  represents the standby current specification.

## Automatic Sleep Mode

The automatic sleep mode minimizes flash device energy consumption. The device automatically enables this mode when addresses remain stable for  $t_{ACC} + 30$  ns. The automatic sleep mode is independent of the CE#, WE#, and OE# control signals. Standard address access timings provide new data when addresses are changed. While in sleep mode, output data is latched and always available to the system.

## RESET#: Hardware Reset Pin

The RESET# pin provides a hardware method of resetting the device to reading array data. When the system drives the RESET# pin low for at least a period of  $t_{RP}$ , the device **immediately terminates** any operation in progress, tristates all data output pins, and ignores all read/write attempts for the duration of the RESET# pulse. The device also resets the internal state machine to reading array data. The operation that was interrupted should be reinitiated once the device is ready to accept another command sequence, to ensure data integrity. Current is reduced for the duration of the RESET# pulse.

The RESET# pin may be tied to the system reset circuitry. A system reset would thus also reset the Flash memory, enabling the system to read the boot-up firmware from the Flash memory.

If RESET# is asserted during a program or erase operation, the RY/BY# pin remains a “0” (busy) until the internal reset operation is complete, which requires a time of  $t_{READY}$  (during Embedded Algorithms). The system can thus monitor RY/BY# to determine whether the reset operation is complete. If RESET# is asserted when a program or erase operation is not executing (RY/BY# pin is “1”), the reset operation is completed within a time of  $t_{READY}$  (not during Embedded Algorithms). The system can read data  $t_{RH}$  after the RESET# pin returns to  $V_{IH}$ .

Refer to the AC Characteristics tables for RESET# parameters and timing diagram.

## Output Disable Mode

When the OE# input is at  $V_{IH}$ , output from the device is disabled. The output pins are placed in the high impedance state.

Table 2. Am29F160DT Sector Address Table (Top Boot)

Sector	A19	A18	A17	A16	A15	A14	A13	A12	Sector Size (Kbytes/ Kwords)	Address Range (in hexadecimal)	
										Byte Mode (x8)	Word Mode (x16)
SA0	0	0	0	0	0	X	X	X	64/32	000000–00FFFF	00000–07FFF
SA1	0	0	0	0	1	X	X	X	64/32	010000–01FFFF	08000–0FFFF
SA2	0	0	0	1	0	X	X	X	64/32	020000–02FFFF	10000–17FFF
SA3	0	0	0	1	1	X	X	X	64/32	030000–03FFFF	18000–1FFFF
SA4	0	0	1	0	0	X	X	X	64/32	040000–04FFFF	20000–27FFF
SA5	0	0	1	0	1	X	X	X	64/32	050000–05FFFF	28000–2FFFF
SA6	0	0	1	1	0	X	X	X	64/32	060000–06FFFF	30000–37FFF
SA7	0	0	1	1	1	X	X	X	64/32	070000–07FFFF	38000–3FFFF
SA8	0	1	0	0	0	X	X	X	64/32	080000–08FFFF	40000–47FFF
SA9	0	1	0	0	1	X	X	X	64/32	090000–09FFFF	48000–4FFFF
SA10	0	1	0	1	0	X	X	X	64/32	0A0000–0AFFFF	50000–57FFF
SA11	0	1	0	1	1	X	X	X	64/32	0B0000–0BFFFF	58000–5FFFF
SA12	0	1	1	0	0	X	X	X	64/32	0C0000–0CFFFF	60000–67FFF
SA13	0	1	1	0	1	X	X	X	64/32	0D0000–0DFFFF	68000–6FFFF
SA14	0	1	1	1	0	X	X	X	64/32	0E0000–0EFFFF	70000–77FFF
SA15	0	1	1	1	1	X	X	X	64/32	0F0000–0FFFFF	78000–7FFFF
SA16	1	0	0	0	0	X	X	X	64/32	100000–10FFFF	80000–87FFF
SA17	1	0	0	0	1	X	X	X	64/32	110000–11FFFF	88000–8FFFF
SA18	1	0	0	1	0	X	X	X	64/32	120000–12FFFF	90000–97FFF
SA19	1	0	0	1	1	X	X	X	64/32	130000–13FFFF	98000–9FFFF
SA20	1	0	1	0	0	X	X	X	64/32	140000–14FFFF	A0000–A7FFF
SA21	1	0	1	0	1	X	X	X	64/32	150000–15FFFF	A8000–AFFFF
SA22	1	0	1	1	0	X	X	X	64/32	160000–16FFFF	B0000–B7FFF
SA23	1	0	1	1	1	X	X	X	64/32	170000–17FFFF	B8000–BFFFF
SA24	1	1	0	0	0	X	X	X	64/32	180000–18FFFF	C0000–C7FFF
SA25	1	1	0	0	1	X	X	X	64/32	190000–19FFFF	C8000–CFFFF
SA26	1	1	0	1	0	X	X	X	64/32	1A0000–1AFFFF	D0000–D7FFF
SA27	1	1	0	1	1	X	X	X	64/32	1B0000–1BFFFF	D8000–DFFFF
SA28	1	1	1	0	0	X	X	X	64/32	1C0000–1CFFFF	E0000–E7FFF
SA29	1	1	1	0	1	X	X	X	64/32	1D0000–1DFFFF	E8000–EFFFF
SA30	1	1	1	1	0	X	X	X	64/32	1E0000–1EFFFF	F0000–F7FFF
SA31	1	1	1	1	1	0	X	X	32/16	1F0000–1F7FFF	F8000–FBFFF
SA32	1	1	1	1	1	1	0	0	8/4	1F8000–1F9FFF	FC000–FCFFF
SA33	1	1	1	1	1	1	0	1	8/4	1FA000–1FBFFF	FD000–FDFFF
SA34	1	1	1	1	1	1	1	X	16/8	1FC000–1FFFFF	FE000–FFFFF

**Note:** Address range is A19:A-1 in byte mode and A19:A0 in word mode. See “Word/Byte Configuration” section.

Table 3. Am29F160DB Sector Address Table (Bottom Boot)

Sector	A19	A18	A17	A16	A15	A14	A13	A12	Sector Size (Kbytes/ Kwords)	Address Range (in hexadecimal)	
										Byte Mode (x8)	Word Mode (x16)
SA0	0	0	0	0	0	0	0	X	16/8	000000–003FFF	00000–01FFF
SA1	0	0	0	0	0	0	1	0	8/4	004000–005FFF	02000–02FFF
SA2	0	0	0	0	0	0	1	1	8/4	006000–007FFF	03000–03FFF
SA3	0	0	0	0	0	1	X	X	32/16	008000–00FFFF	04000–07FFF
SA4	0	0	0	0	1	X	X	X	64/32	010000–01FFFF	08000–0FFFF
SA5	0	0	0	1	0	X	X	X	64/32	020000–02FFFF	10000–17FFF
SA6	0	0	0	1	1	X	X	X	64/32	030000–03FFFF	18000–1FFFF
SA7	0	0	1	0	0	X	X	X	64/32	040000–04FFFF	20000–27FFF
SA8	0	0	1	0	1	X	X	X	64/32	050000–05FFFF	28000–2FFFF
SA9	0	0	1	1	0	X	X	X	64/32	060000–06FFFF	30000–37FFF
SA10	0	0	1	1	1	X	X	X	64/32	070000–07FFFF	38000–3FFFF
SA11	0	1	0	0	0	X	X	X	64/32	080000–08FFFF	40000–47FFF
SA12	0	1	0	0	1	X	X	X	64/32	090000–09FFFF	48000–4FFFF
SA13	0	1	0	1	0	X	X	X	64/32	0A0000–0AFFFF	50000–57FFF
SA14	0	1	0	1	1	X	X	X	64/32	0B0000–0BFFFF	58000–5FFFF
SA15	0	1	1	0	0	X	X	X	64/32	0C0000–0CFFFF	60000–67FFF
SA16	0	1	1	0	1	X	X	X	64/32	0D0000–0DFFFF	68000–6FFFF
SA17	0	1	1	1	0	X	X	X	64/32	0E0000–0EFFFF	70000–77FFF
SA18	0	1	1	1	1	X	X	X	64/32	0F0000–0FFFFF	78000–7FFFF
SA19	1	0	0	0	0	X	X	X	64/32	100000–10FFFF	80000–87FFF
SA20	1	0	0	0	1	X	X	X	64/32	110000–11FFFF	88000–8FFFF
SA21	1	0	0	1	0	X	X	X	64/32	120000–12FFFF	90000–97FFF
SA22	1	0	0	1	1	X	X	X	64/32	130000–13FFFF	98000–9FFFF
SA23	1	0	1	0	0	X	X	X	64/32	140000–14FFFF	A0000–A7FFF
SA24	1	0	1	0	1	X	X	X	64/32	150000–15FFFF	A8000–AFFFF
SA25	1	0	1	1	0	X	X	X	64/32	160000–16FFFF	B0000–B7FFF
SA26	1	0	1	1	1	X	X	X	64/32	170000–17FFFF	B8000–BFFFF
SA27	1	1	0	0	0	X	X	X	64/32	180000–18FFFF	C0000–C7FFF
SA28	1	1	0	0	1	X	X	X	64/32	190000–19FFFF	C8000–CFFFF
SA29	1	1	0	1	0	X	X	X	64/32	1A0000–1AFFFF	D0000–D7FFF
SA30	1	1	0	1	1	X	X	X	64/32	1B0000–1BFFFF	D8000–DFFFF
SA31	1	1	1	0	0	X	X	X	64/32	1C0000–1CFFFF	E0000–E7FFF
SA32	1	1	1	0	1	X	X	X	64/32	1D0000–1DFFFF	E8000–EFFFF
SA33	1	1	1	1	0	X	X	X	64/32	1E0000–1EFFFF	F0000–F7FFF
SA34	1	1	1	1	1	X	X	X	64/32	1F0000–1FFFFF	F8000–FFFFF

**Note:** Address range is A19:A-1 in byte mode and A19:A0 in word mode. See the [Word/Byte Configuration, on page 8](#).

## Autoselect Mode

The autoselect mode provides manufacturer and device identification, and sector protection verification, through identifier codes output on DQ7–DQ0. This mode is primarily intended for programming equipment to automatically match a device to be programmed with its corresponding programming algorithm. However, the autoselect codes can also be accessed in-system through the command register.

When using programming equipment, the autoselect mode requires  $V_{ID}$  (11.5 V to 12.5 V) on address pin A9. Address pins A6, A1, and A0 must be as shown in Autoselect Codes (High Voltage Method) table. In addition, when verifying sector protection, the sector address

must appear on the appropriate highest order address bits. Refer to the corresponding Sector Address Tables. The Command Definitions table shows the remaining address bits that are don't care. When all necessary bits are set as required, the programming equipment may then read the corresponding identifier code on DQ7–DQ0.

To access the autoselect codes in-system, the host system can issue the autoselect command via the command register, as shown in the Command Definitions table. This method does not require  $V_{ID}$ . See [Command Definitions, on page 18](#) for details on using the autoselect mode.

**Table 4. Am29F160D Autoselect Codes (High Voltage Method)**

Description	Mode	CE#	OE#	WE#	A19 to A12	A11 to A10	A9	A8 to A7	A6	A5 to A2	A1	A0	DQ8 to DQ15	DQ7 to DQ0
Manufacturer ID: AMD		L	L	H	X	X	$V_{ID}$	X	L	X	L	L	X	01h
Device ID: Am29F160D (Top Boot Block)	Word	L	L	H	X	X	$V_{ID}$	X	L	X	L	H	22h	D2h
	Byte	L	L	H									X	D2h
Device ID: Am29F160D (Bottom Boot Block)	Word	L	L	H	X	X	$V_{ID}$	X	L	X	L	H	22h	D8h
	Byte	L	L	H									X	D8h
Sector Protection Verification		L	L	H	SA	X	$V_{ID}$	X	L	X	H	L	X	01h (protected)
													X	00h (unprotected)

$L = \text{Logic Low} = V_{IL}$ ,  $H = \text{Logic High} = V_{IH}$ ,  $SA = \text{Sector Address}$ ,  $X = \text{Don't care}$ .

## Sector Protection/Unprotection

The hardware sector protection feature disables both program and erase operations in any sector. The hardware sector unprotection feature re-enables both program and erase operations in previously protected sectors.

The device is shipped with all sectors unprotected. AMD offers the option of programming and protecting sectors at its factory prior to shipping the device through AMD's ExpressFlash™ Service. Contact an AMD representative for details.

It is possible to determine whether a sector is protected or unprotected. See [Autoselect Mode, on page 12](#) for details.

Sector protection/unprotection can be implemented via two methods.

The primary method requires  $V_{ID}$  on the RESET# pin only, and can be implemented either in-system or via programming equipment. [Figure 2, on page 14](#) shows the algorithms and [Figure 20, on page 39](#) shows the timing diagram. This method uses standard microprocessor bus cycle timing. For sector unprotect, all unprotected sectors must first be protected prior to the first sector unprotect write cycle.

The alternate method intended only for programming equipment requires  $V_{ID}$  on address pin A9 and OE#. This method is compatible with programmer routines written for earlier 5.0 volt-only AMD flash devices. Details on this method are provided in a supplement, publication number 22289. Contact an AMD representative to request a copy.

## Write Protect (WP#)

The Write Protect function provides a hardware method of protecting the 16 Kbyte boot sector from erasure without using  $V_{ID}$ .

If the system asserts  $V_{IL}$  on the WP# pin, the device disables erase functions for the 16 Kbyte boot sector (SA34 for top boot device and SA0 for bottom boot device) independently of whether those sectors were protected or unprotected using the method described in [Sector Protection/Unprotection, on page 12](#).

If the system asserts  $V_{IH}$  on the WP# pin, the device reverts to whether the 16 Kbyte boot sector was previously set to be protected or unprotected using the method described in [Sector Protection/Unprotection, on page 12](#).

## Temporary Sector Unprotect

This feature allows temporary unprotection of previously protected sectors to change data in-system. The Sector Unprotect mode is activated by setting the RESET# pin to  $V_{ID}$ . During this mode, formerly protected sectors can be programmed or erased by selecting the sector addresses. However, note that the boot sector is still protected from erasure only if WP# is asserted low. Once  $V_{ID}$  is removed from the RESET# pin, all the previously protected sectors are protected again. [Figure 2, on page 14](#) shows the algorithm, and [Figure 19, on page 38](#) shows the timing diagrams, for this feature.

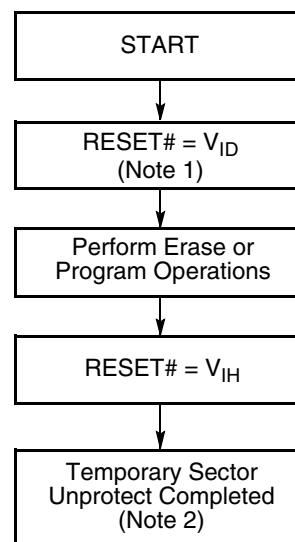

### Notes:

1. All protected sectors unprotected. However, boot sector remains protected from erasure only if WP# is low.
2. All previously protected sectors are protected once again.

**Figure 1. Temporary Sector Unprotect Operation**

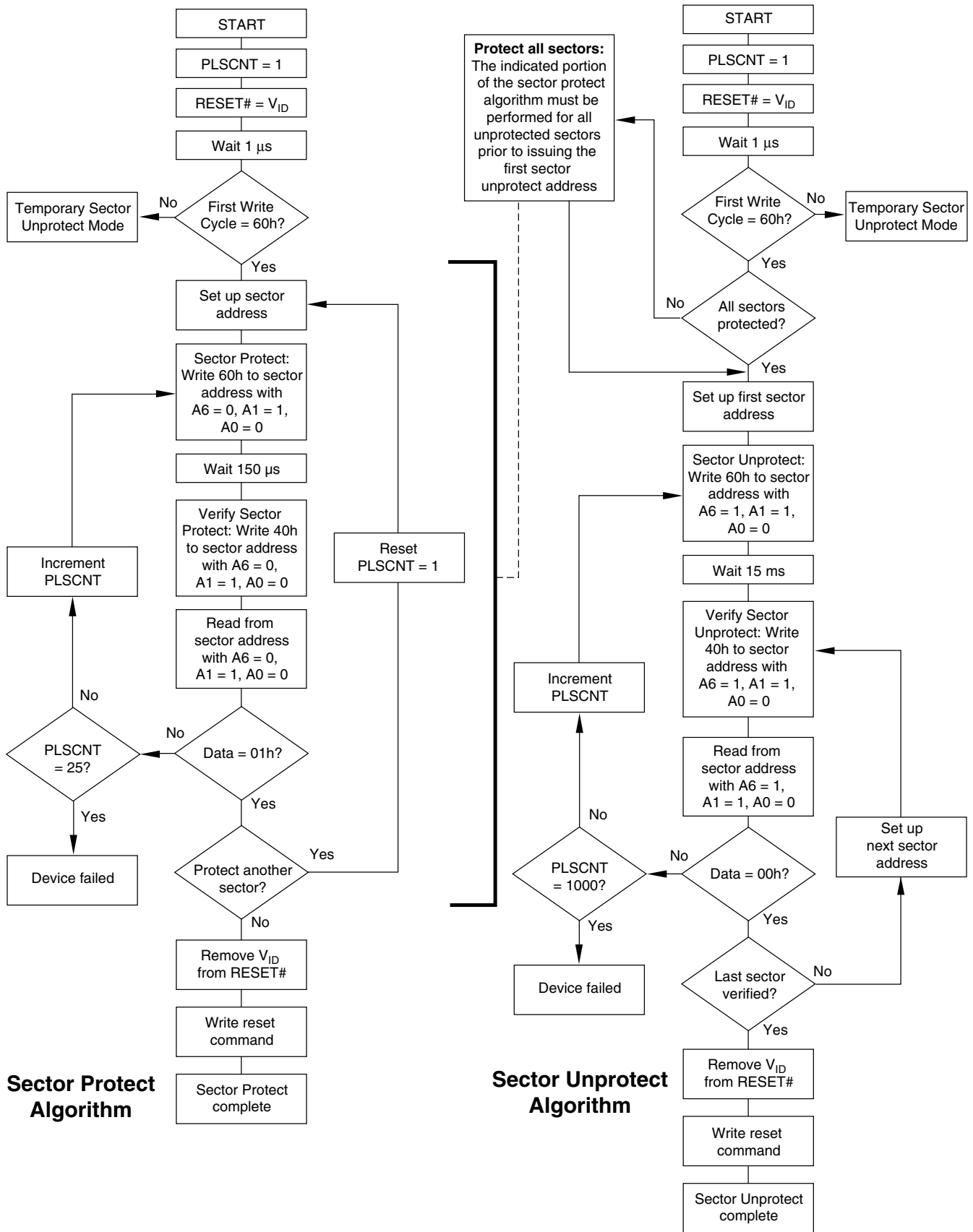

Figure 2. In-System Sector Protect/Unprotect Algorithms



## COMMON FLASH MEMORY INTERFACE (CFI)

The Common Flash Interface (CFI) specification outlines device and host system software interrogation handshake, which allows specific vendor-specified software algorithms to be used for entire families of devices. Software support can then be device-independent, JEDEC ID-independent, and forward- and backward-compatible for the specified flash device families. Flash vendors can standardize their existing interfaces for long-term compatibility.

This device enters the CFI Query mode when the system writes the CFI Query command, 98h, to address 55h in word mode (or address AAh in byte mode), any time the device is ready to read array data. The system can read CFI information at the addresses given in [Table 5 on page 15](#), [Table 6 on page 16](#),

[Table 7 on page 16](#), and [–Table 8 on page 17](#). In word mode, the upper address bits (A7–MSB) must be all zeros. To terminate reading CFI data, the system must write the reset command.

The system can also write the CFI query command when the device is in the autoselect mode. The device enters the CFI query mode, and the system can read CFI data at the addresses given in [Table 5 on page 15](#), [Table 6 on page 16](#), [Table 7 on page 16](#), and [–Table 8 on page 17](#). The system must write the reset command to return the device to the autoselect mode.

For further information, please refer to the CFI Specification and CFI Publication 100, available via the World Wide Web at <http://www.amd.com/products/nvd/overview/cfi.html>. Alternatively, contact an AMD representative for copies of these documents.

**Table 5. CFI Query Identification String**

Addresses (Word Mode)	Addresses (Byte Mode)	Data	Description
10h 11h 12h	20h 22h 24h	0051h 0052h 0059h	Query Unique ASCII string “QRY”
13h 14h	26h 28h	0002h 0000h	Primary OEM Command Set
15h 16h	2Ah 2Ch	0040h 0000h	Address for Primary Extended Table
17h 18h	2Eh 30h	0000h 0000h	Alternate OEM Command Set (00h = none exists)
19h 1Ah	32h 34h	0000h 0000h	Address for Alternate OEM Extended Table (00h = none exists)

Table 6. System Interface String

Addresses (Word Mode)	Addresses (Byte Mode)	Data	Description
1Bh	36h	0045h	V <sub>CC</sub> Min. (write/erase) D7–D4: volt, D3–D0: 100 millivolt
1Ch	38h	0055h	V <sub>CC</sub> Max. (write/erase) D7–D4: volt, D3–D0: 100 millivolt
1Dh	3Ah	0000h	V <sub>PP</sub> Min. voltage (00h = no V <sub>PP</sub> pin present)
1Eh	3Ch	0000h	V <sub>PP</sub> Max. voltage (00h = no V <sub>PP</sub> pin present)
1Fh	3Eh	0004h	Typical timeout per single byte/word write 2 <sup>N</sup> μs
20h	40h	0000h	Typical timeout for Min. size buffer write 2 <sup>N</sup> μs (00h = not supported)
21h	42h	000Ah	Typical timeout per individual block erase 2 <sup>N</sup> ms
22h	44h	0000h	Typical timeout for full chip erase 2 <sup>N</sup> ms (00h = not supported)
23h	46h	0005h	Max. timeout for byte/word write 2 <sup>N</sup> times typical
24h	48h	0000h	Max. timeout for buffer write 2 <sup>N</sup> times typical
25h	4Ah	0004h	Max. timeout per individual block erase 2 <sup>N</sup> times typical
26h	4Ch	0000h	Max. timeout for full chip erase 2 <sup>N</sup> times typical (00h = not supported)

Table 7. Device Geometry Definition

Addresses (Word Mode)	Addresses (Byte Mode)	Data	Description
27h	4Eh	0015h	Device Size = 2 <sup>N</sup> byte
28h 29h	50h 52h	0002h 0000h	Flash Device Interface description (refer to CFI publication 100)
2Ah 2Bh	54h 56h	0000h 0000h	Max. number of byte in multi-byte write = 2 <sup>N</sup> (00h = not supported)
2Ch	58h	0004h	Number of Erase Block Regions within device
2Dh 2Eh 2Fh 30h	5Ah 5Ch 5Eh 60h	0000h 0000h 0040h 0000h	Erase Block Region 1 Information (refer to the CFI specification or CFI publication 100)
31h 32h 33h 34h	62h 64h 66h 68h	0001h 0000h 0020h 0000h	Erase Block Region 2 Information
35h 36h 37h 38h	6Ah 6Ch 6Eh 70h	0000h 0000h 0080h 0000h	Erase Block Region 3 Information
39h 3Ah 3Bh 3Ch	72h 74h 76h 78h	001Eh 0000h 0000h 0001h	Erase Block Region 4 Information

Table 8. Primary Vendor-Specific Extended Query

Addresses (Word Mode)	Addresses (Byte Mode)	Data	Description
40h 41h 42h	80h 82h 84h	0050h 0052h 0049h	Query-unique ASCII string "PRI"
43h	86h	0031h	Major version number, ASCII
44h	88h	0031h	Minor version number, ASCII
45h	8Ah	0000h	Address Sensitive Unlock 0 = Required, 1 = Not Required
46h	8Ch	0002h	Erase Suspend 0 = Not Supported, 1 = To Read Only, 2 = To Read & Write
47h	8Eh	0001h	Sector Protect 0 = Not Supported, X = Number of sectors per group
48h	90h	0001h	Sector Temporary Unprotect 00 = Not Supported, 01 = Supported
49h	92h	0004h	Sector Protect/Unprotect scheme 01 = 29F040 mode, 02 = 29F016 mode, 03 = 29F400 mode, 04 = 29LV800A mode
4Ah	94h	0000h	Simultaneous Operation 00 = Not Supported, 01 = Supported
4Bh	96h	0000h	Burst Mode Type 00 = Not Supported, 01 = Supported
4Ch	98h	0000h	Page Mode Type 00 = Not Supported, 01 = 4 Word Page, 02 = 8 Word Page
4Dh	9Ah	0000h	ACC Supply Minimum
4Eh	9Ch	0000h	ACC Supply Maximum
4Fh	9Eh	0002h, 0003h	Top/Bottom Boot Sector Flag 02 = bottom, 03 = top

## Hardware Data Protection

The command sequence requirement of unlock cycles for programming or erasing provides data protection against inadvertent writes (refer to the Command Definitions table). In addition, the following hardware data protection measures prevent accidental erasure or programming, which might otherwise be caused by spurious system level signals during  $V_{CC}$  power-up and power-down transitions, or from system noise.

### Low $V_{CC}$ Write Inhibit

When  $V_{CC}$  is less than  $V_{LKO}$ , the device does not accept any write cycles. This protects data during  $V_{CC}$  power-up and power-down. The command register and all internal program/erase circuits are disabled, and the device resets. Subsequent writes are ignored until  $V_{CC}$  is greater than  $V_{LKO}$ . The system must provide the

proper signals to the control pins to prevent unintentional writes when  $V_{CC}$  is greater than  $V_{LKO}$ .

### Write Pulse “Glitch” Protection

Noise pulses of less than 5 ns (typical) on OE#, CE# or WE# do not initiate a write cycle.

### Logical Inhibit

Write cycles are inhibited by holding any one of OE# =  $V_{IL}$ , CE# =  $V_{IH}$  or WE# =  $V_{IH}$ . To initiate a write cycle, CE# and WE# must be a logical zero while OE# is a logical one.

### Power-Up Write Inhibit

If WE# = CE# =  $V_{IL}$  and OE# =  $V_{IH}$  during power up, the device does not accept commands on the rising edge of WE#. The internal state machine is automatically reset to reading array data on power-up.

## COMMAND DEFINITIONS

Writing specific address and data commands or sequences into the command register initiates device operations. The Command Definitions table defines the valid register command sequences. Writing **incorrect address and data values** or writing them in the **improper sequence** resets the device to reading array data.

All addresses are latched on the falling edge of WE# or CE#, whichever happens later. All data is latched on the rising edge of WE# or CE#, whichever happens first. Refer to the appropriate timing diagrams in the “AC Characteristics” section.

### Reading Array Data

The device is automatically set to reading array data after device power-up. No commands are required to retrieve data. The device is also ready to read array data after completing an Embedded Program or Embedded Erase algorithm.

After the device accepts an Erase Suspend command, the device enters the Erase Suspend mode. The system can read array data using the standard read timings, except that if it reads at an address within erase-suspended sectors, the device outputs status data. After completing a programming operation in the Erase Suspend mode, the system may once again read array data with the same exception. See [Erase Suspend/Erased Resume Commands, on page 21](#) for more information on this mode.

The system *must* issue the reset command to re-enable the device for reading array data if DQ5 goes high,

or while in the autoselect mode. See the [Reset Command, on page 18](#) section, next.

See also [Requirements for Reading Array Data, on page 8](#) for more information. The Read Operations table provides the read parameters, and Read Operation Timings diagram shows the timing diagram.

### Reset Command

Writing the reset command to the device resets the device to reading array data. Address bits are don't care for this command.

The reset command may be written between the sequence cycles in an erase command sequence before erasing begins. This resets the device to reading array data. Once erasure begins, however, the device ignores reset commands until the operation is complete.

The reset command may be written between the sequence cycles in a program command sequence before programming begins. This resets the device to reading array data (also applies to programming in Erase Suspend mode). Once programming begins, however, the device ignores reset commands until the operation is complete.

The reset command may be written between the sequence cycles in an autoselect command sequence. Once in the autoselect mode, the reset command *must* be written to return to reading array data (also applies to autoselect during Erase Suspend).

If DQ5 goes high during a program or erase operation, writing the reset command returns the device to reading array data (also applies during Erase Suspend).

## Autoselect Command Sequence

The autoselect command sequence allows the host system to access the manufacturer and device codes, and determine whether or not a sector is protected. The Command Definitions table shows the address and data requirements. This method is an alternative to that shown in the Autoselect Codes (High Voltage Method) table, which is intended for PROM programmers and requires  $V_{ID}$  on address bit A9.

The autoselect command sequence is initiated by writing two unlock cycles, followed by the autoselect command. The device then enters the autoselect mode, and the system may read at any address any number of times, without initiating another command sequence.

A read cycle at address XX00h retrieves the manufacturer code. A read cycle at address XX01h in word mode (or 02h in byte mode) returns the device code.

A read cycle containing a sector address (SA) and the address 02h in word mode (or 04h in byte mode) returns 01h if that sector is protected, or 00h if it is unprotected. Refer to the Sector Address tables for valid sector addresses. When a read occurs at an address within the 16 Kbyte boot sector (SA34 for top boot devices and SA0 for bottom boot devices), the input on WP# may determine what code is returned.

16Kb Sector Protection	WP# input	Autoselect Code
protected	$V_{IH}$	01 (protected)
protected	$V_{IL}$	01 (protected)
unprotected	$V_{IH}$	00 (unprotected)
unprotected	$V_{IL}$	01 (protected) <sup>1</sup>

<sup>1</sup> Sector is protected from erasure. Programming operations within sector is still permitted.

The system must write the reset command to exit the autoselect mode and return to reading array data.

## Word/Byte Program Command Sequence

The system may program the device by byte or word, on depending on the state of the BYTE# pin. Programming is a four-bus-cycle operation. The program command sequence is initiated by writing two unlock write cycles, followed by the program set-up command. The program address and data are written next, which in turn initiate the Embedded Program algorithm. The system is *not* required to provide further controls or timings. The device automatically provides internally gen-

erated program pulses and verify the programmed cell margin. The Command Definitions table shows the address and data requirements for the byte program command sequence.

When the Embedded Program algorithm is complete, the device then returns to reading array data and addresses are no longer latched. The system can determine the status of the program operation by using DQ7, DQ6, or RY/BY#. See "Write Operation Status" for information on these status bits.

Any commands written to the device during the Embedded Program Algorithm are ignored. Note that a **hardware reset** immediately terminates the programming operation. The program command sequence should be reinitiated once the device resets to reading array data, to ensure data integrity.

Programming is allowed in any sequence and across sector boundaries. **A bit cannot be programmed from a "0" back to a "1"**. Attempting to do so may halt the operation and set DQ5 to "1", or cause the Data# Polling algorithm to indicate the operation was successful. However, a succeeding read shows that the data is still "0". Only erase operations can convert a "0" to a "1".

## Unlock Bypass Command Sequence

The unlock bypass feature allows the system to program words to the device faster than using the standard program command sequence. The unlock bypass command sequence is initiated by first writing two unlock cycles. This is followed by a third write cycle containing the unlock bypass command, 20h. The device then enters the unlock bypass mode. A two-cycle unlock bypass program command sequence is all that is required to program in this mode. The first cycle in this sequence contains the unlock bypass program command, A0h; the second cycle contains the program address and data. Additional data is programmed in the same manner. This mode dispenses with the initial two unlock cycles required in the standard program command sequence, resulting in faster total programming time. [Table 9 on page 22](#) shows the requirements for the command sequence.

During the unlock bypass mode, only the Unlock Bypass Program and Unlock Bypass Reset commands are valid. To exit the unlock bypass mode, the system must issue the two-cycle unlock bypass reset command sequence. The first cycle must contain the data 90h. The second cycle must contain the data 00h. The device then returns to the read mode.

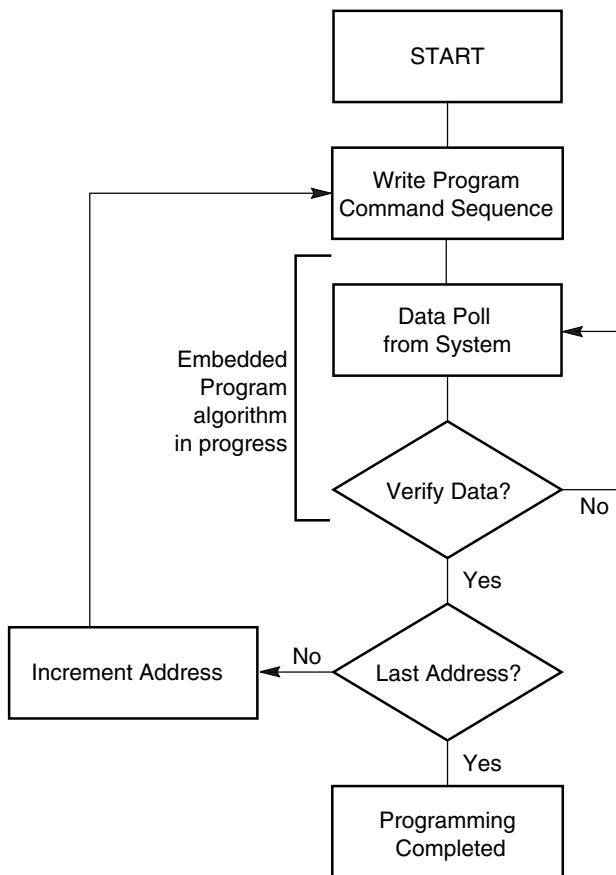

**Note:** See the appropriate Command Definitions table for program command sequence.

**Figure 3. Program Operation**

## Chip Erase Command Sequence

Chip erase is a six-bus-cycle operation. The chip erase command sequence is initiated by writing two unlock cycles, followed by a set-up command. Two additional unlock write cycles are then followed by the chip erase command, which in turn invokes the Embedded Erase algorithm. The device does *not* require the system to preprogram prior to erase. The Embedded Erase algorithm automatically preprograms and verifies the entire memory for an all zero data pattern prior to electrical erase. The system is not required to provide any controls or timings during these operations. The Command Definitions table shows the address and data requirements for the chip erase command sequence.

Any commands written to the chip during the Embedded Erase algorithm are ignored. Note that a **hardware reset** during the chip erase operation immediately terminates the operation. The Chip Erase command sequence should be reinitiated once the device returns to reading array data, to ensure data integrity.

The system can determine the status of the erase operation by using DQ7, DQ6, DQ2, or RY/BY#. See [Write Operation Status, on page 23](#) for information on these status bits. When the Embedded Erase algorithm is complete, the device returns to reading array data and addresses are no longer latched.

[Figure 4, on page 21](#) illustrates the algorithm for the erase operation. See the Erase/Program Operations tables in “AC Characteristics” for parameters, and to the Chip/Sector Erase Operation Timings for timing waveforms.

## Sector Erase Command Sequence

Sector erase is a six bus cycle operation. The sector erase command sequence is initiated by writing two unlock cycles, followed by a set-up command. Two additional unlock write cycles are then followed by the address of the sector to be erased, and the sector erase command. The Command Definitions table shows the address and data requirements for the sector erase command sequence.

The device does *not* require the system to preprogram the memory prior to erase. The Embedded Erase algorithm automatically programs and verifies the sector for an all zero data pattern prior to electrical erase. The system is not required to provide any controls or timings during these operations.

After the command sequence is written, a sector erase time-out of 50  $\mu$ s begins. During the time-out period, additional sector addresses and sector erase commands may be written. Loading the sector erase buffer may be done in any sequence, and the number of sectors may be from one sector to all sectors. The time between these additional cycles must be less than 50  $\mu$ s, otherwise the last address and command might not be accepted, and erasure may begin. It is recommended that processor interrupts be disabled during this time to ensure all commands are accepted. The interrupts can be re-enabled after the last Sector Erase command is written. If the time between additional sector erase commands can be assumed to be less than 50  $\mu$ s, the system need not monitor DQ3. **Any command other than Sector Erase or Erase Suspend during the time-out period resets the device to reading array data.** The system must rewrite the command sequence and any additional sector addresses and commands.

The system can monitor DQ3 to determine if the sector erase timer has timed out. (See the [DQ3: Sector Erase Timer, on page 25](#) section.) The time-out begins from the rising edge of the final WE# pulse in the command sequence.

Once the sector erase operation begins, only the Erase Suspend command is valid. All other commands are ignored. Note that a **hardware reset** during the sector erase operation immediately terminates the operation.



The Sector Erase command sequence should be reinitiated once the device returns to reading array data, to ensure data integrity.

When the Embedded Erase algorithm is complete, the device returns to reading array data and addresses are no longer latched. The system can determine the status of the erase operation by using DQ7, DQ6, DQ2, or RY/BY#. Refer to [Write Operation Status, on page 23](#) for information on these status bits.

Figure 4, on page 21 illustrates the algorithm for the erase operation. Refer to the Erase/Program Operations tables in the [AC Characteristics, on page 31](#) for parameters, and to the Sector Erase Operations Timing diagram for timing waveforms.

### Erase Suspend/Erase Resume Commands

The Erase Suspend command allows the system to interrupt a sector erase operation and then read data from, or program data to, any sector not selected for erasure. This command is valid only during the sector erase operation, including the 50  $\mu$ s time-out period during the sector erase command sequence. The Erase Suspend command is ignored if written during the chip erase operation or Embedded Program algorithm. Writing the Erase Suspend command during the Sector Erase time-out immediately terminates the time-out period and suspends the erase operation. Addresses are “don’t-cares” when writing the Erase Suspend command.

When the Erase Suspend command is written during a sector erase operation, the device requires a maximum of 20  $\mu$ s to suspend the erase operation. However, when the Erase Suspend command is written during the sector erase time-out, the device immediately terminates the time-out period and suspends the erase operation.

After the erase operation is suspended, the system can read array data from or program data to any sector not selected for erasure. (The device “erase suspends” all sectors selected for erasure.) Normal read and write timings and command definitions apply. Reading at any address within erase-suspended sectors produces status data on DQ7–DQ0. The system can use DQ7, or DQ6 and DQ2 together, to determine if a sector is actively erasing or is erase-suspended. See [Write Operation Status, on page 23](#) for information on these status bits.

After an erase-suspended program operation is complete, the system can once again read array data within non-suspended sectors. The system can determine

the status of the program operation using the DQ7 or DQ6 status bits, just as in the standard program operation. See [Write Operation Status, on page 23](#) for more information.

The system may also write the autoselect command sequence when the device is in the Erase Suspend mode. The device allows reading autoselect codes even at addresses within erasing sectors, since the codes are not stored in the memory array. When the device exits the autoselect mode, the device reverts to the Erase Suspend mode, and is ready for another valid operation. See [Autoselect Command Sequence, on page 19](#) for more information.

The system must write the Erase Resume command (address bits are “don’t care”) to exit the erase suspend mode and continue the sector erase operation. Further writes of the Resume command are ignored. Another Erase Suspend command can be written after the device resumes erasing.

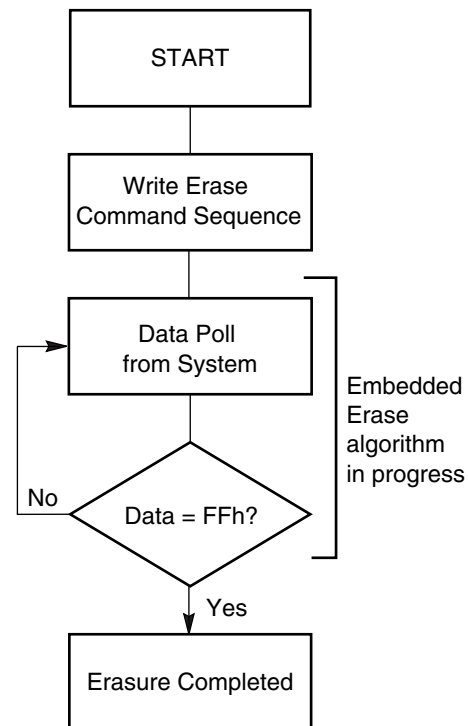

1. See the appropriate Command Definitions table for erase command sequence.
2. See [DQ3: Sector Erase Timer, on page 25](#) for more information.

Figure 4. Erase Operation

Command Definitions

Table 9. Am29F160D Command Definitions

Command Sequence (Note 1)			Cycles	Bus Cycles (Notes 2–5)											
				First		Second		Third		Fourth		Fifth		Sixth	
				Addr	Data	Addr	Data	Addr	Data	Addr	Data	Addr	Data	Addr	Data
Read (Note 6)			1	RA	RD										
Reset (Note 7)			1	XXX	F0										
Autoselect (Note 8)	Manufacturer ID	Word	4	555	AA	2AA	55	555	90	X00	01				
		Byte		AAA		555		AAA							
	Device ID, Top Boot Block	Word	4	555	AA	2AA	55	555	90	X01	22D2				
		Byte		AAA		555		AAA		X02		D2			
	Device ID, Bottom Boot Block	Word	4	555	AA	2AA	55	555	90	X01	22D8				
		Byte		AAA		555		AAA		X02		D8			
	Sector Protect Verify (Note 9)	Word	4	555	AA	2AA	55	555	90	(SA) X02	XX00 XX01				
		Byte		AAA		555		AAA		(SA) X04		00 01			
CFI Query (Note 10)		Word	1	555	98										
		Byte		AAA											
Program		Word	4	555	AA	2AA	55	555	A0	PA	PD				
		Byte		AAA		555		AAA							
Unlock Bypass		Word	3	555	AA	2AA	55	555	20						
		Byte		AAA		555		AAA							
Unlock Bypass Program (Note 11)			2	XXX	A0	PA	PD								
Unlock Bypass Reset (Note 12)			2	XXX	90	XXX	00								
Chip Erase		Word	6	555	AA	2AA	55	555	80	555	AA	2AA	55	555	10
		Byte		AAA		555		AAA		555		AAA			
Sector Erase		Word	6	555	AA	2AA	55	555	80	555	AA	2AA	55	SA	30
		Byte		AAA		555		AAA		555		AAA			
Erase Suspend (Note 13)			1	XXX	B0										
Erase Resume (Note 14)			1	XXX	30										

Legend:

X = Don't care

RA = Address of the memory location to be read.

RD = Data read from location RA during read operation.

PA = Address of the memory location to be programmed. Addresses latch on the falling edge of the WE# or CE# pulse, whichever happens later.

PD = Data to be programmed at location PA. Data latches on the rising edge of WE# or CE# pulse, whichever happens first.

SA = Address of the sector to be verified (in autoselect mode) or erased. Address bits A19–A12 uniquely select any sector.

Notes:

- See Table 1 on page 8 for description of bus operations.
- All values are in hexadecimal.
- Except when reading array or autoselect data, all bus cycles are write operations.
- Data bits DQ15–DQ8 are don't cares for unlock and command cycles.
- Address bits A19–A11 are don't cares for unlock and command cycles, unless SA or PA required.
- No unlock or command cycles required when reading array data.
- The Reset command is required to return to reading array data when device is in the autoselect mode, CFI query mode, or if DQ5 goes high (while the device is providing status data).
- The fourth cycle of the autoselect command sequence is a read cycle.
- The data is 00h for an unprotected sector and 01h for a protected sector. See Autoselect Command Sequence, on page 19 for more information.
- Command is valid when device is ready to read array data or when device is in autoselect mode.
- The Unlock Bypass command is required prior to the Unlock Bypass Program command.
- The Unlock Bypass Reset command is required to return to reading array data when the device is in the unlock bypass mode.
- The system may read and program in non-erasing sectors, or enter the autoselect mode, when in the Erase Suspend mode. The Erase Suspend command is valid only during a sector erase operation.
- The Erase Resume command is valid only during the Erase Suspend mode.



## WRITE OPERATION STATUS

The device provides several bits to determine the status of a write operation: DQ2, DQ3, DQ5, DQ6, DQ7, and RY/BY#. Table 10 on page 26 and the following subsections describe the functions of these bits. DQ7, RY/BY#, and DQ6 each offer a method for determining whether a program or erase operation is complete or in progress. These three bits are discussed first.

### DQ7: Data# Polling

The Data# Polling bit, DQ7, indicates to the host system whether an Embedded Algorithm is in progress or completed, or whether the device is in Erase Suspend. Data# Polling is valid after the rising edge of the final WE# pulse in the program or erase command sequence.

During the Embedded Program algorithm, the device outputs on DQ7 the complement of the datum programmed to DQ7. This DQ7 status also applies to programming during Erase Suspend. When the Embedded Program algorithm is complete, the device outputs the datum programmed to DQ7. The system must provide the program address to read valid status information on DQ7. If a program address falls within a protected sector, Data# Polling on DQ7 is active for approximately 2  $\mu$ s, then the device returns to reading array data.

During the Embedded Erase algorithm, Data# Polling produces a “0” on DQ7. When the Embedded Erase algorithm is complete, or if the device enters the Erase Suspend mode, Data# Polling produces a “1” on DQ7. This is analogous to the complement/true datum output described for the Embedded Program algorithm: the erase function changes all the bits in a sector to “1”; prior to this, the device outputs the “complement,” or “0.” The system must provide an address within any of the sectors selected for erasure to read valid status information on DQ7.

After an erase command sequence is written, if all sectors selected for erasing are protected, Data# Polling on DQ7 is active for approximately 100  $\mu$ s, then the device returns to reading array data. If not all selected sectors are protected, the Embedded Erase algorithm erases the unprotected sectors, and ignores the selected sectors that are protected.

When the system detects DQ7 changes from the complement to true data, it can read valid data at DQ7–DQ0 on the following read cycles. This is because DQ7 may change asynchronously with DQ0–DQ6 while Output Enable (OE#) is asserted low. The Data# Polling Timings (During Embedded Algorithms) figure in the “AC Characteristics” section illustrates this.

Table 10 on page 26 shows the outputs for Data# Polling on DQ7. Figure 5 shows the Data# Polling algorithm.

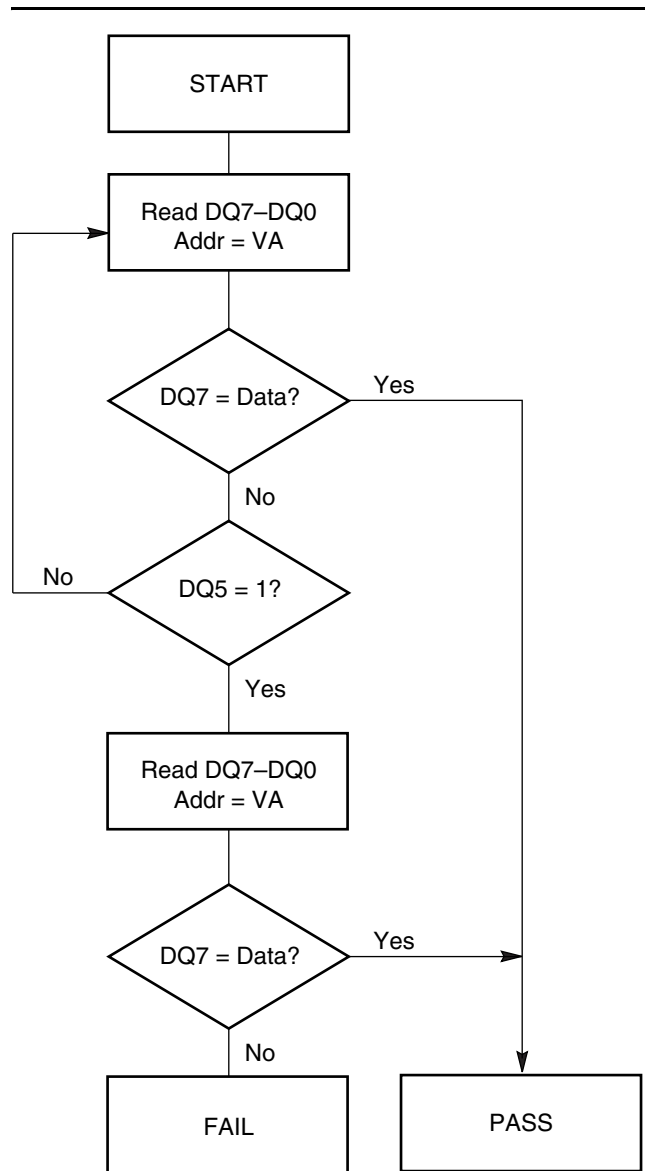

#### Notes:

1. VA = Valid address for programming. During a sector erase operation, a valid address is an address within any sector selected for erasure. During chip erase, a valid address is any non-protected sector address.
2. DQ7 should be rechecked even if DQ5 = “1” because DQ7 may change simultaneously with DQ5.

Figure 5. Data# Polling Algorithm

## **RY/BY#: Ready/Busy#**

The RY/BY# is a dedicated, open-drain output pin that indicates whether an Embedded Algorithm is in progress or complete. The RY/BY# status is valid after the rising edge of the final WE# pulse in the command sequence. Since RY/BY# is an open-drain output, several RY/BY# pins can be tied together in parallel with a pull-up resistor to  $V_{CC}$ .

If the output is low (Busy), the device is actively erasing or programming. (This includes programming in the Erase Suspend mode.) If the output is high (Ready), the device is ready to read array data (including during the Erase Suspend mode), or is in the standby mode.

Table 10 on page 26 shows the outputs for RY/BY#. The timing diagrams for read, reset, program, and erase shows the relationship of RY/BY# to other signals.

## **DQ6: Toggle Bit I**

Toggle Bit I on DQ6 indicates whether an Embedded Program or Erase algorithm is in progress or complete, or whether the device entered the Erase Suspend mode. Toggle Bit I may be read at any address, and is valid after the rising edge of the final WE# pulse in the command sequence (prior to the program or erase operation), and during the sector erase time-out.

During an Embedded Program or Erase algorithm operation, successive read cycles to any address cause DQ6 to toggle. (The system may use either OE# or CE# to control the read cycles.) When the operation is complete, DQ6 stops toggling.

After an erase command sequence is written, if all sectors selected for erasing are protected, DQ6 toggles for approximately 100  $\mu$ s, then returns to reading array data. If not all selected sectors are protected, the Embedded Erase algorithm erases the unprotected sectors, and ignores the selected sectors that are protected.

The system can use DQ6 and DQ2 together to determine whether a sector is actively erasing or is erase-suspended. When the device is actively erasing (that is, the Embedded Erase algorithm is in progress), DQ6 toggles. When the device enters the Erase Suspend mode, DQ6 stops toggling. However, the system must also use DQ2 to determine which sectors are erasing or erase-suspended. Alternatively, the system can use DQ7 (see the subsection on [DQ7: Data# Polling, on page 23](#)).

If a program address falls within a protected sector, DQ6 toggles for approximately 2  $\mu$ s after the program command sequence is written, then returns to reading array data.

DQ6 also toggles during the erase-suspend-program mode, and stops toggling once the Embedded Program algorithm is complete.

The Write Operation Status table shows the outputs for Toggle Bit I on DQ6. Refer to [Figure 6, on page 25](#) for the toggle bit algorithm, and to the Toggle Bit Timings figure in the “AC Characteristics” section for the timing diagram. The DQ2 vs. DQ6 figure shows the differences between DQ2 and DQ6 in graphical form. See also the subsection on [DQ2: Toggle Bit II, on page 24](#).

## **DQ2: Toggle Bit II**

The “Toggle Bit II” on DQ2, when used with DQ6, indicates whether a particular sector is actively erasing (that is, the Embedded Erase algorithm is in progress), or whether that sector is erase-suspended. Toggle Bit II is valid after the rising edge of the final WE# pulse in the command sequence.

DQ2 toggles when the system reads at addresses within those sectors that were selected for erasure. (The system may use either OE# or CE# to control the read cycles.) But DQ2 cannot distinguish whether the sector is actively erasing or is erase-suspended. DQ6, by comparison, indicates whether the device is actively erasing, or is in Erase Suspend, but cannot distinguish which sectors are selected for erasure. Thus, both status bits are required for sector and mode information. Refer to [Table 10 on page 26](#) to compare outputs for DQ2 and DQ6.

[Figure 6, on page 25](#) shows the toggle bit algorithm in flowchart form, and the section “[DQ2: Toggle Bit II](#)” explains the algorithm. See also the “[DQ6: Toggle Bit I](#)” subsection. Refer to the Toggle Bit Timings figure for the toggle bit timing diagram. The DQ2 vs. DQ6 figure shows the differences between DQ2 and DQ6 in graphical form.

## **Reading Toggle Bits DQ6/DQ2**

Refer to [Figure 6, on page 25](#) for the following discussion. Whenever the system initially begins reading toggle bit status, it must read DQ7–DQ0 at least twice in a row to determine whether a toggle bit is toggling. Typically, a system would note and store the value of the toggle bit after the first read. After the second read, the system would compare the new value of the toggle bit with the first. If the toggle bit is not toggling, the device completed the program or erase operation. The system can read array data on DQ7–DQ0 on the following read cycle.

However, if after the initial two read cycles, the system determines that the toggle bit is still toggling, the system also should note whether the value of DQ5 is high (see the section on DQ5). If it is, the system should then determine again whether the toggle bit is toggling, since the toggle bit may have stopped toggling just as DQ5 went high. If the toggle bit is no longer

toggling, the device successfully completed the program or erase operation. If it is still toggling, the device did not complete the operation successfully, and the system must write the reset command to return to reading array data.

The remaining scenario is that the system initially determines that the toggle bit is toggling and DQ5 has not gone high. The system may continue to monitor the toggle bit and DQ5 through successive read cycles, determining the status as described in the previous paragraph. Alternatively, it may choose to perform other system tasks. In this case, the system must start at the beginning of the algorithm when it returns to determine the status of the operation (top of Figure 6).

### DQ5: Exceeded Timing Limits

DQ5 indicates whether the program or erase time exceeded a specified internal pulse count limit. Under these conditions DQ5 produces a “1.” This is a failure condition that indicates the program or erase cycle was not successfully completed.

The DQ5 failure condition may appear if the system tries to program a “1” to a location that is previously programmed to “0.” **Only an erase operation can change a “0” back to a “1.”** Under this condition, the device halts the operation, and when the operation exceeds the timing limits, DQ5 produces a “1.”

Under both these conditions, the system must issue the reset command to return the device to reading array data.

### DQ3: Sector Erase Timer

After writing a sector erase command sequence, the system may read DQ3 to determine whether or not an erase operation begun. (The sector erase timer does not apply to the chip erase command.) If additional sectors are selected for erasure, the entire time-out also applies after each additional sector erase command. When the time-out is complete, DQ3 switches from “0” to “1.” The system may ignore DQ3 if the system can guarantee that the time between additional sector erase commands is always less than 50 μs. See also the [Sector Erase Command Sequence, on page 20](#) section.

After the sector erase command sequence is written, the system should read the status on DQ7 (Data# Polling) or DQ6 (Toggle Bit I) to ensure the device accepted the command sequence, and then read DQ3. If DQ3 is “1”, the internally controlled erase cycle started; all further commands (other than Erase Suspend) are ignored until the erase operation is complete. If DQ3 is “0”, the device accepts additional sector erase com-

mands. To ensure the command is accepted, the system software should check the status of DQ3 prior to and following each subsequent sector erase command. If DQ3 is high on the second status check, the last command might not have been accepted. [Table 10 on page 26](#) shows the outputs for DQ3.

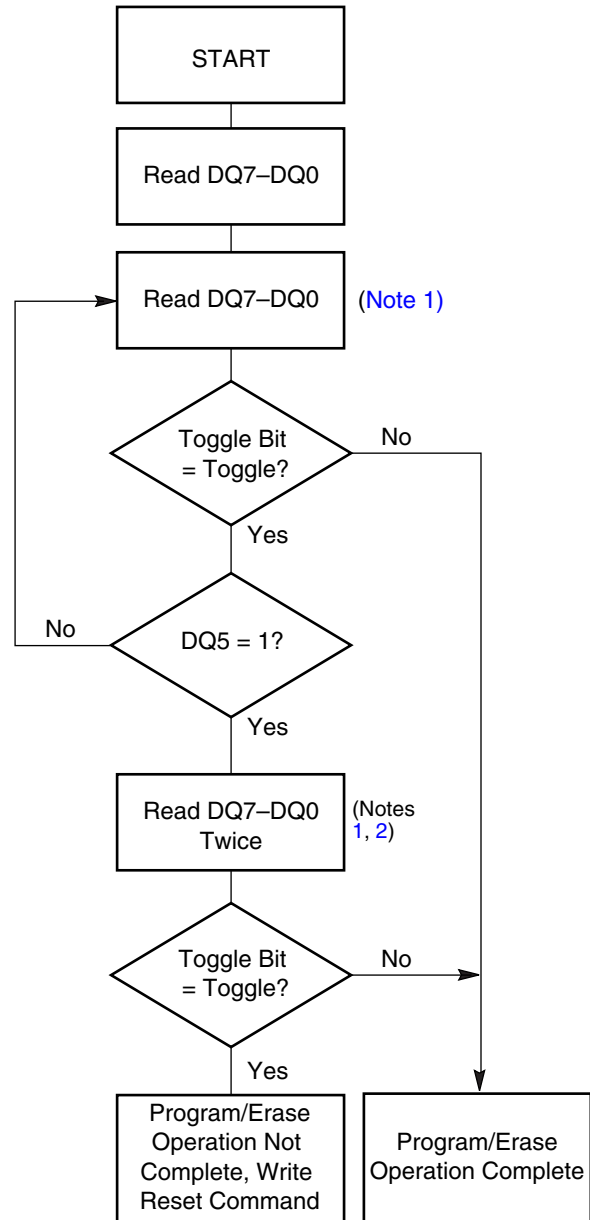

- Notes:**
1. Read toggle bit twice to determine whether or not it is toggling. See text.
  2. Recheck toggle bit because it may stop toggling as DQ5 changes to “1”. See text.

**Figure 6. Toggle Bit Algorithm**

Table 10. Write Operation Status

Operation		DQ7 (Note 1)	DQ6	DQ5 (Note 2)	DQ3	DQ2 (Note 1)	RY/BY#
Standard Mode	Embedded Program Algorithm	DQ7#	Toggle	0	N/A	No toggle	0
	Embedded Erase Algorithm	0	Toggle	0	1	Toggle	0
Erase Suspend Mode	Reading within Erase Suspended Sector	1	No toggle	0	N/A	Toggle	1
	Reading within Non-Erase Suspended Sector	Data	Data	Data	Data	Data	1
	Erase-Suspend-Program	DQ7#	Toggle	0	N/A	N/A	0

**Notes:**

1. DQ7 and DQ2 require a valid address when reading status information. Refer to the appropriate subsection for further details.
2. DQ5 switches to '1' when an Embedded Program or Embedded Erase operation exceeds the maximum timing limits. See [DQ5: Exceeded Timing Limits, on page 25](#) for more information.

## ABSOLUTE MAXIMUM RATINGS

Storage Temperature	
Plastic Packages . . . . .	-65°C to +150°C
Ambient Temperature	
with Power Applied. . . . .	-55°C to +125°C
Voltage with Respect to Ground	
$V_{CC}$ (Note 1) . . . . .	-2.0 V to +7.0 V
A9, OE#, and	
RESET# (Note 2). . . . .	-2.0 V to +12.5 V
All other pins (Note 1) . . . . .	-0.5 V to +7.0 V
Output Short Circuit Current (Note 3) . . . . .	200 mA

**Notes:**

1. Minimum DC voltage on input or I/O pins is -0.5 V. During voltage transitions, input or I/O pins may undershoot  $V_{SS}$  to -2.0 V for periods of up to 20 ns. See Figure 7. Maximum DC voltage on input or I/O pins is  $V_{CC} + 0.5$  V. During voltage transitions, input or I/O pins may overshoot to  $V_{CC} + 2.0$  V for periods up to 20 ns. See Figure 8.
2. Minimum DC input voltage on pins A9, OE#, and RESET# is -0.5 V. During voltage transitions, A9, OE#, and RESET# may undershoot  $V_{SS}$  to -2.0 V for periods of up to 20 ns. See Figure 7. Maximum DC input voltage on pin A9 is +12.5 V which may overshoot to +13.5 V for periods up to 20 ns.
3. No more than one output may be shorted to ground at a time. Duration of the short circuit should not be greater than one second.

**Note:** Stresses above those listed under “Absolute Maximum Ratings” may cause permanent damage to the device. This is a stress rating only; functional operation of the device at these or any other conditions above those indicated in the operational sections of this data sheet is not implied. Exposure of the device to absolute maximum rating conditions for extended periods may affect device reliability.

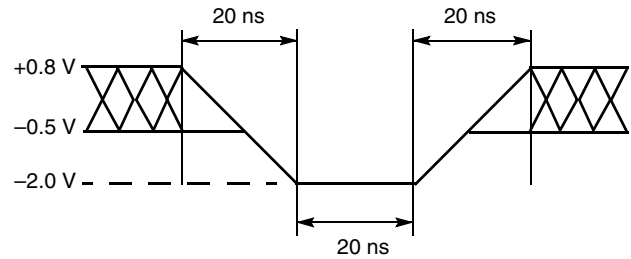

**Figure 7. Maximum Negative Overshoot Waveform**

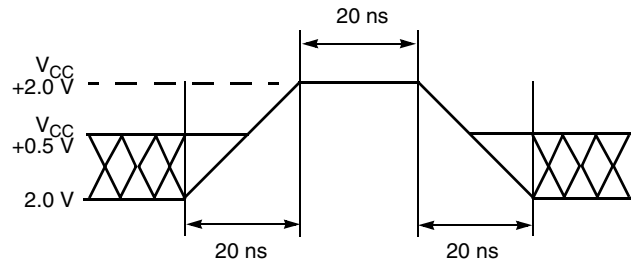

**Figure 8. Maximum Positive Overshoot Waveform**

## OPERATING RANGES

### Commercial (C) Devices

Ambient Temperature ( $T_A$ ) . . . . . 0°C to +70°C

### Industrial (I) Devices

Ambient Temperature ( $T_A$ ) . . . . . -40°C to +85°C

### Extended (E) Devices

Ambient Temperature ( $T_A$ ) . . . . . -55°C to +125°C

### $V_{CC}$ Supply Voltages

$V_{CC}$  for ±5% devices . . . . . +4.75 V to +5.25 V

$V_{CC}$  for ±10% devices . . . . . +4.5 V to +5.5 V

**Note:** Operating ranges define those limits between which the functionality of the device is guaranteed.

## DC CHARACTERISTICS

## TTL/NMOS Compatible

Parameter	Description	Test Conditions	Min	Typ	Max	Unit
$I_{LI}$	Input Load Current	$V_{IN} = V_{SS}$ to $V_{CC}$ , $V_{CC} = V_{CC\ max}$			$\pm 1.0$	$\mu A$
$I_{LIT}$	A9, OE#, RESET Input Load Current	$V_{CC} = V_{CC\ max}$ ; A9 = OE# = RESET# = 12.5 V			35	$\mu A$
$I_{LO}$	Output Leakage Current	$V_{OUT} = V_{SS}$ to $V_{CC}$			$\pm 1.0$	$\mu A$
$I_{CC1}$	$V_{CC}$ Active Read Current (Notes 1, 2)	CE# = $V_{IL}$ , OE# = $V_{IH}$ , $f = 5$ MHz, Byte Mode		15	40	mA
		CE# = $V_{IL}$ , OE# = $V_{IH}$ , $f = 5$ MHz, Word Mode		15	50	mA
$I_{CC2}$	$V_{CC}$ Active Write Current (Notes 2, 3 and 4)	CE# = $V_{IL}$ , OE# = $V_{IH}$		35	50	mA
$I_{CC3}$	$V_{CC}$ Standby Current (Notes 2, 5)	CE#, OE#, and RESET# = $V_{IH}$		0.4	1	mA
$V_{IL}$	Input Low Voltage		-0.5		0.8	V
$V_{IH}$	Input High Voltage		2.0		$V_{CC} + 0.5$	V
$V_{ID}$	Voltage for Autoselect and Temporary Sector Unprotect	$V_{CC} = 5.0$ V	11.5		12.5	V
$V_{OL}$	Output Low Voltage	$I_{OL} = 5.8$ mA, $V_{CC} = V_{CC\ min}$			0.45	V
$V_{OH}$	Output High Voltage	$I_{OH} = -2.5$ mA, $V_{CC} = V_{CC\ min}$	2.4			V
$V_{LKO}$	Low $V_{CC}$ Lock-Out Voltage (Note 4)		3.2		4.2	V

**Notes:**

1. The  $I_{CC}$  current listed is typically less than 2 mA/MHz, with OE# at  $V_{IH}$ .
2. Maximum  $I_{CC}$  specifications are tested with  $V_{CC} = V_{CC\ max}$
3.  $I_{CC}$  active while Embedded Erase or Embedded Program is in progress.
4. Not 100% tested.
5.  $I_{CC3} = 20 \mu A$  max at extended temperature ( $>+85^{\circ}C$ )

## DC CHARACTERISTICS

## CMOS Compatible

Parameter	Description	Test Conditions	Min	Typ	Max	Unit
$I_{LI}$	Input Load Current	$V_{IN} = V_{SS}$ to $V_{CC}$ , $V_{CC} = V_{CC\ max}$			$\pm 1.0$	$\mu A$
$I_{LIT}$	A9, OE#, RESET Input Load Current	$V_{CC} = V_{CC\ max}$ , A9 = OE# = RESET = 12.5 V			35	$\mu A$
$I_{LO}$	Output Leakage Current	$V_{OUT} = V_{SS}$ to $V_{CC}$ , $V_{CC} = V_{CC\ max}$			$\pm 1.0$	$\mu A$
$I_{CC1}$	$V_{CC}$ Active Read Current (Note 2)	CE# = $V_{IL}$ , OE# = $V_{IH}$ , $f = 5$ MHz Byte Mode		15	40	mA
		CE# = $V_{IL}$ , OE# = $V_{IH}$ , $f = 5$ MHz Word Mode		15	50	mA
$I_{CC2}$	$V_{CC}$ Active Write Current (Notes 1, 2, 3)	CE# = $V_{IL}$ , OE# = $V_{IH}$		35	50	mA
$I_{CC3}$	$V_{CC}$ Standby Current (Note 2)	CE# and RESET# = $V_{CC} \pm 0.5$ V, WP# = $V_{CC} \pm 0.5$ V or floating, OE# = $V_{IH}$		0.3	5	$\mu A$
$V_{IL}$	Input Low Voltage		-0.5		0.8	V
$V_{IH}$	Input High Voltage		$0.7 \times V_{CC}$		$V_{CC} + 0.3$	V
$V_{ID}$	Voltage for Autoselect and Temporary Sector Unprotect	$V_{CC} = 5.0$ V	11.5		12.5	V
$V_{OL}$	Output Low Voltage	$I_{OL} = 5.8$ mA, $V_{CC} = V_{CC\ min}$			0.45	V
$V_{OH1}$	Output High Voltage	$I_{OH} = -2.5$ mA, $V_{CC} = V_{CC\ min}$	$0.85 V_{CC}$			V
$V_{OH2}$		$I_{OH} = -100$ $\mu A$ , $V_{CC} = V_{CC\ min}$	$V_{CC} - 0.4$			V
$V_{LKO}$	Low $V_{CC}$ Lock-Out Voltage (Note 3)		3.2		4.2	V

**Notes:**

- $I_{CC}$  active while Embedded Erase or Embedded Program is in progress.
- Maximum  $I_{CC}$  specifications are tested with  $V_{CC} = V_{CC\ max}$
- Not 100% tested.

TEST CONDITIONS

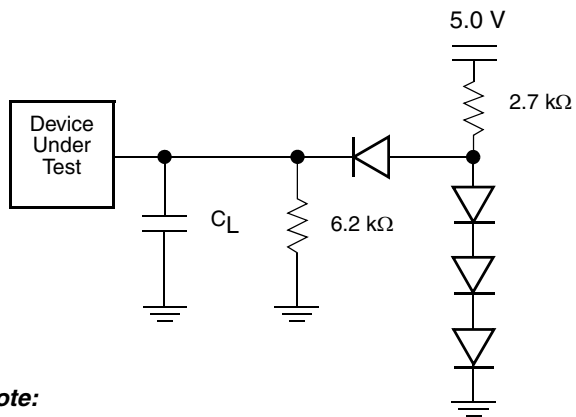

**Note:**  
Diodes are IN3064 or equivalents.

Table 11. Test Specifications

Test Condition	70, 75	90	Unit
Output Load	1 TTL gate		
Output Load Capacitance, $C_L$ (including jig capacitance)	30	100	pF
Input Rise and Fall Times	5	20	ns
Input Pulse Levels	0.0–3.0	0.45–2.4	V
Input timing measurement reference levels	1.5	0.8, 2.0	V
Output timing measurement reference levels	1.5	0.8, 2.0	V

Figure 9. Test Setup

KEY TO SWITCHING WAVEFORMS

WAVEFORM	INPUTS	OUTPUTS
	Steady	
	Changing from H to L	
	Changing from L to H	
	Don't Care, Any Change Permitted	Changing, State Unknown
	Does Not Apply	Center Line is High Impedance State (High Z)



## AC CHARACTERISTICS

### Read Operations

Parameter		Description	Test Setup	Speed Option		Unit	
JEDEC	Std.			70, 75	90		
$t_{AVAV}$	$t_{RC}$	Read Cycle Time (Note 1)	Min	70	90	ns	
$t_{AVQV}$	$t_{ACC}$	Address to Output Delay	CE# = $V_{IL}$ OE# = $V_{IL}$	Max	70	90	ns
$t_{ELQV}$	$t_{CE}$	Chip Enable to Output Delay	OE# = $V_{IL}$	Max	70	90	ns
$t_{GLQV}$	$t_{OE}$	Output Enable to Output Delay		Max	30	35	ns
$t_{EHQZ}$	$t_{DF}$	Chip Enable to Output High Z (Note 1)		Max	20	20	ns
$t_{GHQZ}$	$t_{DF}$	Output Enable to Output High Z (Note 1)		Max	20	20	ns
	$t_{OEh}$	Output Enable Hold Time (Note 1)	Read	Min	0	ns	
			Toggle and Data# Polling	Min	10	ns	
$t_{AXQX}$	$t_{OH}$	Output Hold Time From Addresses, CE# or OE#, Whichever Occurs First (Note 1)	Min	0		ns	

**Notes:**

1. Not 100% tested.
2. See Figure 9, on page 30 and Table 11 on page 30 for test specifications.

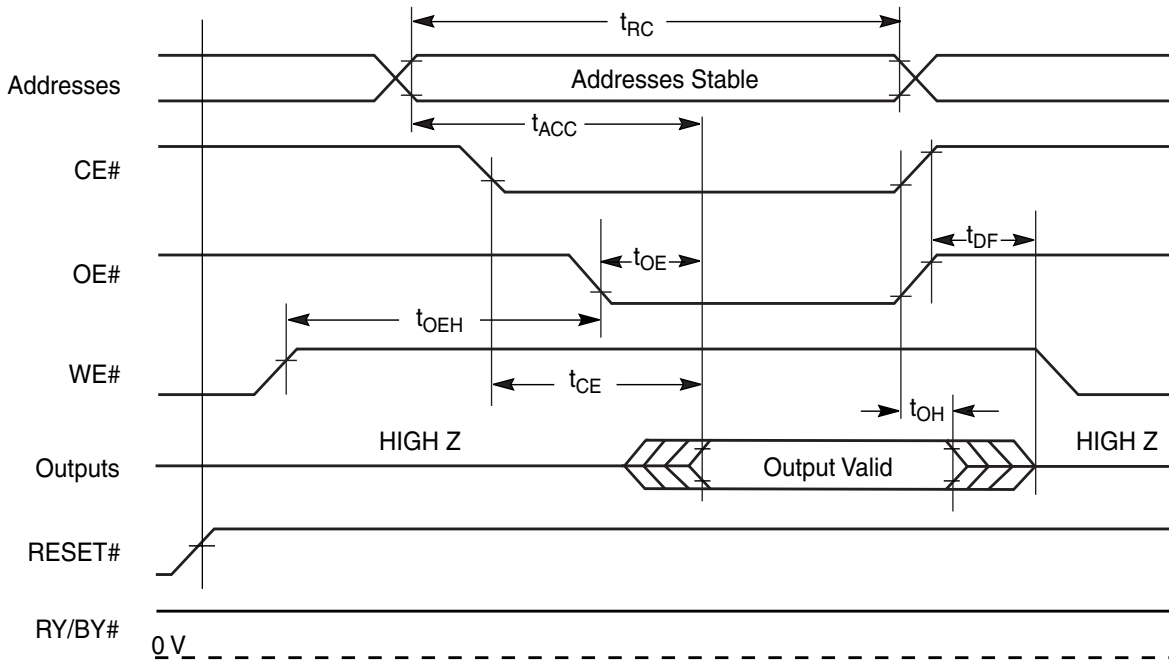
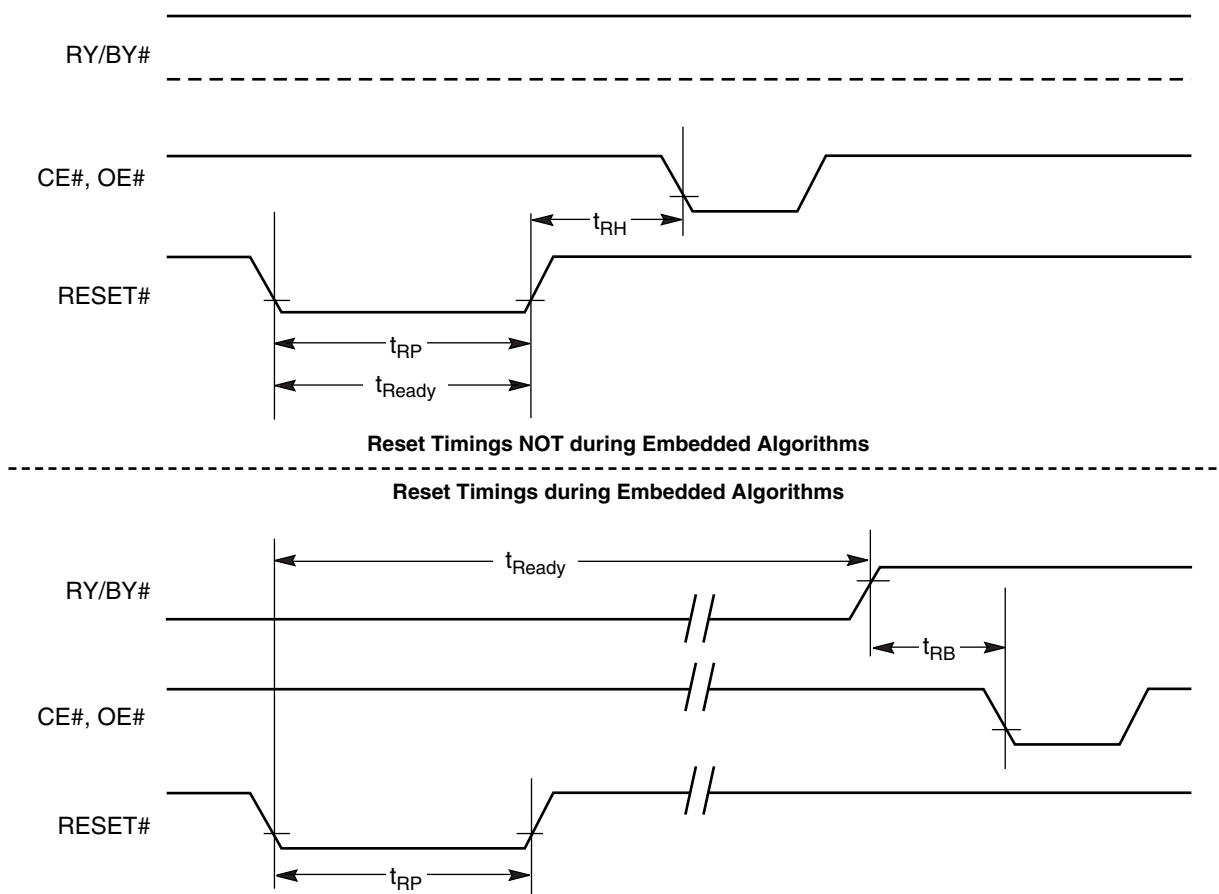

Figure 10. Read Operations Timings

**AC CHARACTERISTICS**  
**Hardware Reset (RESET#)**

Parameter		Description	Test Setup		All Speed Options	Unit
JEDEC	Std					
	$t_{\text{READY}}$	RESET# Pin Low (During Embedded Algorithms) to Read or Write (See Note)		Max	20	$\mu\text{s}$
	$t_{\text{READY}}$	RESET# Pin Low (NOT During Embedded Algorithms) to Read or Write (See Note)		Max	500	ns
	$t_{\text{RP}}$	RESET# Pulse Width		Min	500	ns
	$t_{\text{RH}}$	RESET# High Time Before Read (See Note)		Min	50	ns
	$t_{\text{RB}}$	RY/BY# Recovery Time		Min	0	ns

**Note:** Not 100% tested.



**Figure 11. RESET# Timings**

**AC CHARACTERISTICS**  
**Word/Byte Configuration (BYTE#)**

Parameter		Description		Speed Options		Unit
JEDEC	Std.			70, 75	90	
	$t_{ELFL}/t_{ELFH}$	CE# to BYTE# Switching Low or High	Max	5		ns
	$t_{FLQZ}$	BYTE# Switching Low to Output HIGH Z	Max	20	20	ns
	$t_{FHQV}$	BYTE# Switching High to Output Active	Min	70	90	ns

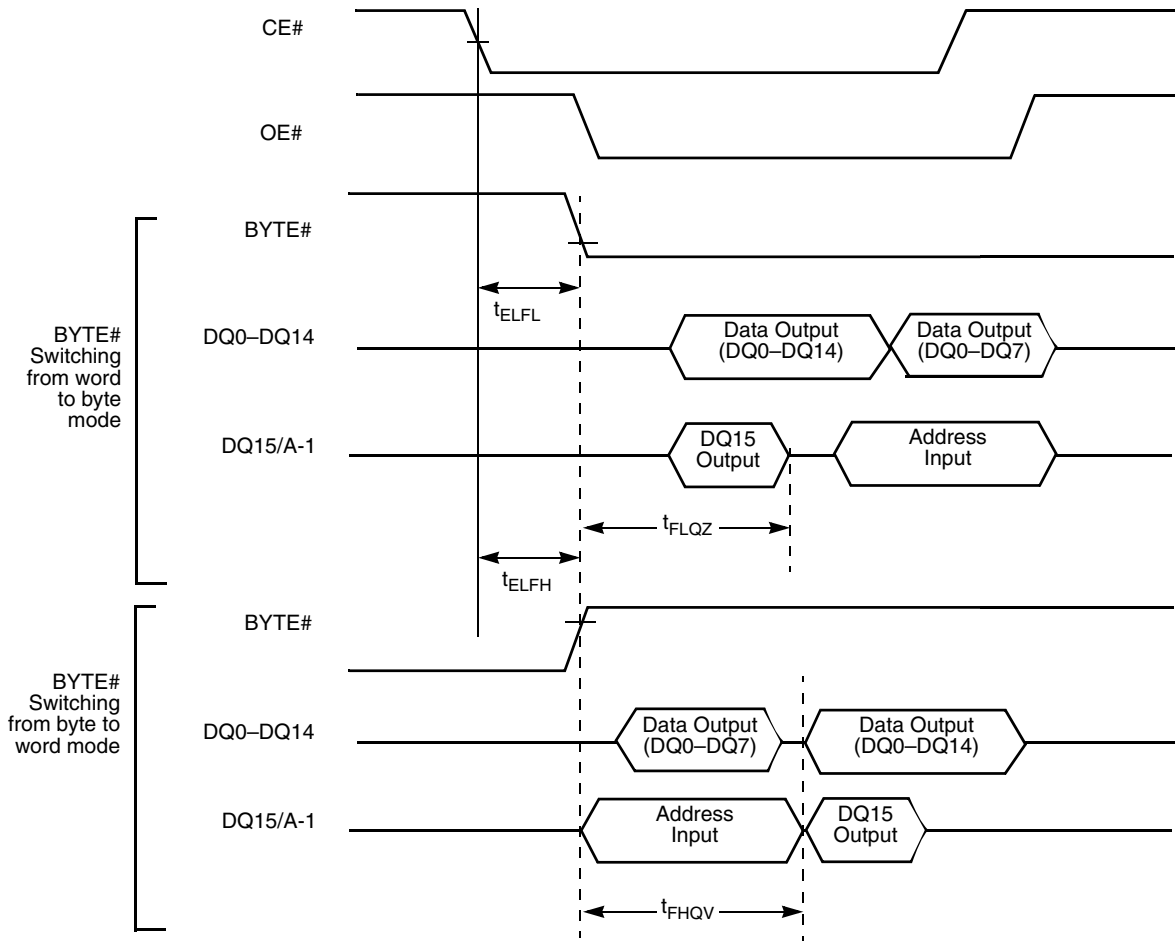

**Figure 12. BYTE# Timings for Read Operations**

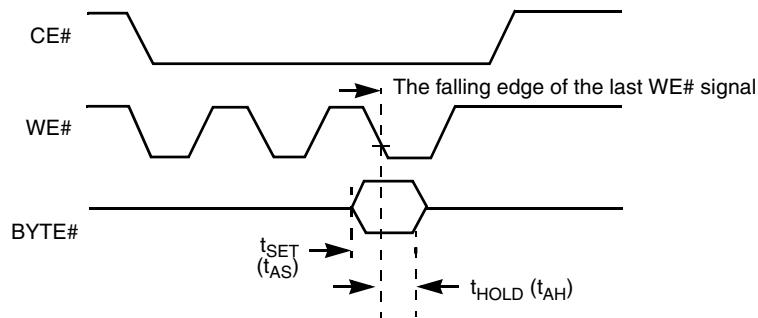

**Note:** Refer to the Erase/Program Operations table for  $t_{AS}$  and  $t_{AH}$  specifications.

**Figure 13. BYTE# Timings for Write Operations**

## AC CHARACTERISTICS

### Erase/Program Operations

Parameter		Description		Speed Options		Unit
JEDEC	Std.			70, 75	90	
$t_{AVAV}$	$t_{WC}$	Write Cycle Time (Note 1)	Min	70	90	ns
$t_{AVWL}$	$t_{AS}$	Address Setup Time	Min	0		ns
$t_{WLAX}$	$t_{AH}$	Address Hold Time	Min	45	45	ns
$t_{DVWH}$	$t_{DS}$	Data Setup Time	Min	30	45	ns
$t_{WHDX}$	$t_{DH}$	Data Hold Time	Min	0		ns
	$t_{OES}$	Output Enable Setup Time	Min	0		ns
$t_{GHWL}$	$t_{GHWL}$	Read Recovery Time Before Write (OE# High to WE# Low)	Min	0		ns
$t_{ELWL}$	$t_{CS}$	CE# Setup Time	Min	0		ns
$t_{WHEH}$	$t_{CH}$	CE# Hold Time	Min	0		ns
$t_{WLWH}$	$t_{WP}$	Write Pulse Width	Min	35	45	ns
$t_{WHWL}$	$t_{WPH}$	Write Pulse Width High	Min	20		ns
$t_{WHWH1}$	$t_{WHWH1}$	Programming Operation (Note 2)	Byte	Typ	7	$\mu$ s
			Word	Typ	12	
$t_{WHWH2}$	$t_{WHWH2}$	Sector Erase Operation (Note 2)	Typ	1		sec
	$t_{VCS}$	$V_{CC}$ Setup Time (Note 1)	Min	50		$\mu$ s
	$t_{RB}$	Recovery Time from RY/BY#	Min	0		ns
	$t_{BUSY}$	Program/Erase Valid to RY/BY# Delay	Max	30	35	ns

**Notes:**

1. Not 100% tested.
2. See [Erase and Programming Performance, on page 42](#) for more information.

AC CHARACTERISTICS

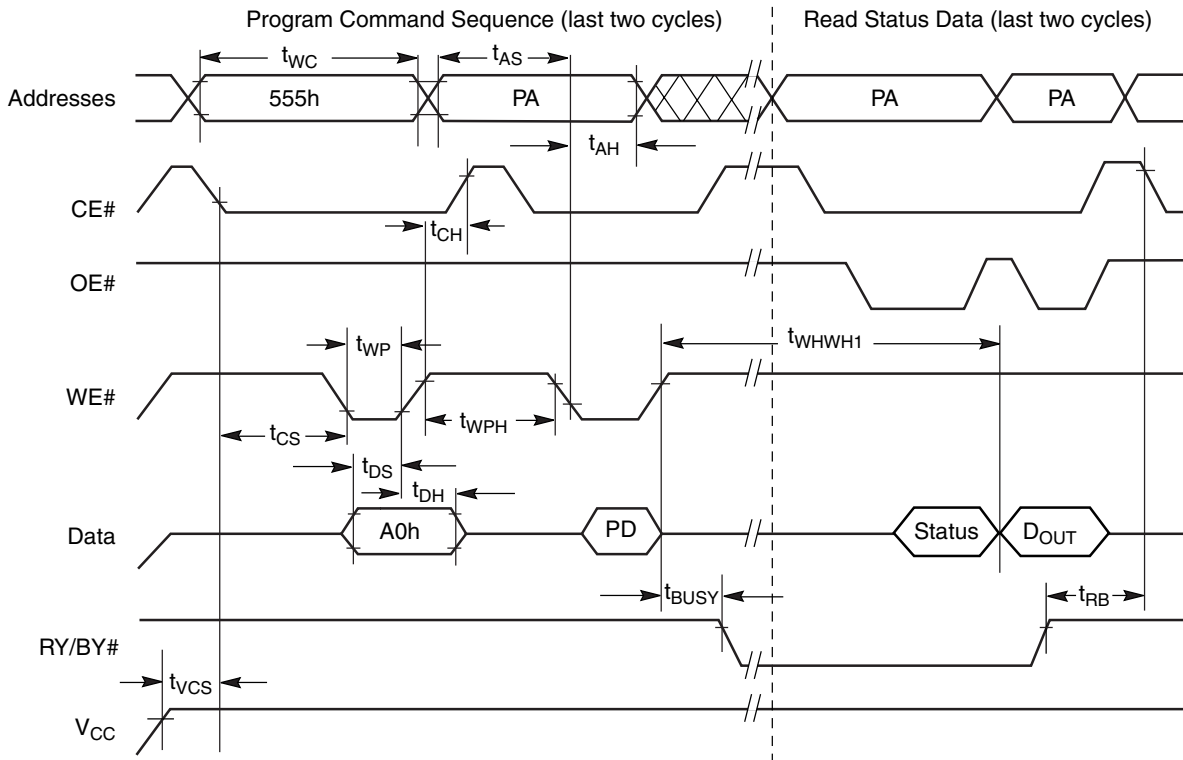

Notes:

1. PA = program address, PD = program data, D<sub>OUT</sub> is the true data at the program address.
2. Illustration shows device in word mode.

Figure 14. Program Operation Timings

AC CHARACTERISTICS

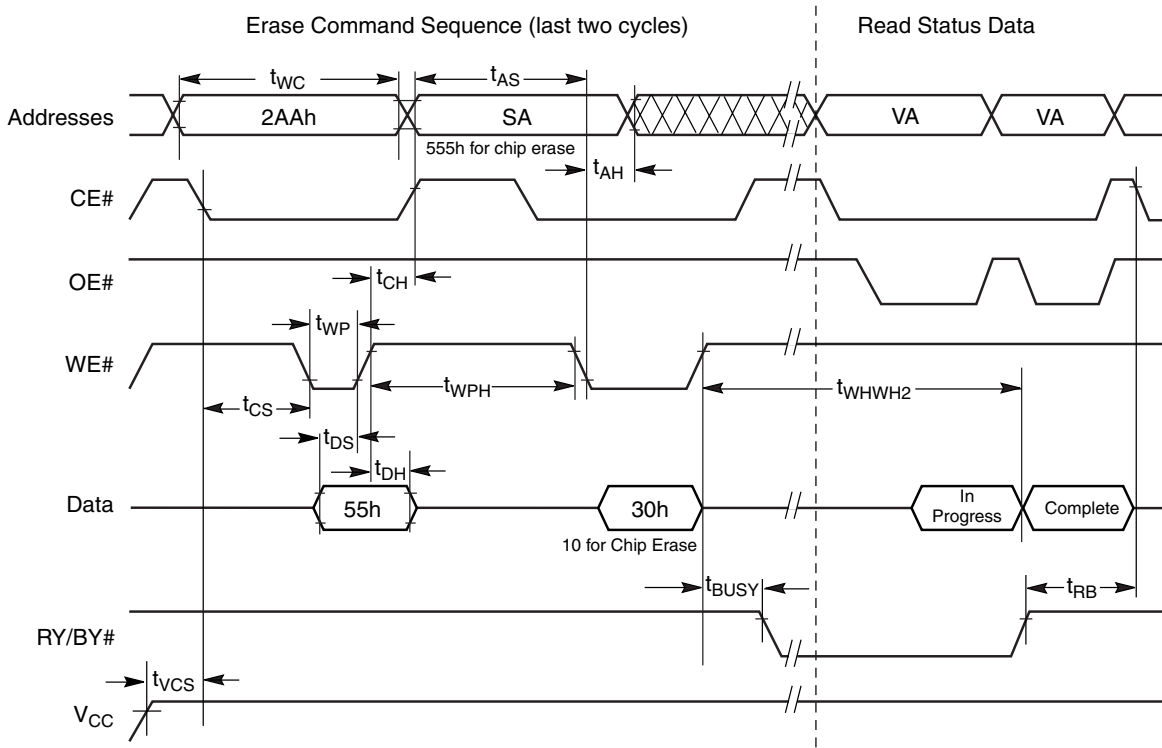

Notes:

1. SA = sector address (for Sector Erase), VA = Valid Address for reading status data (see [Write Operation Status, on page 23](#)).
2. Illustration shows device in word mode.

Figure 15. Chip/Sector Erase Operation Timings

**AC CHARACTERISTICS**

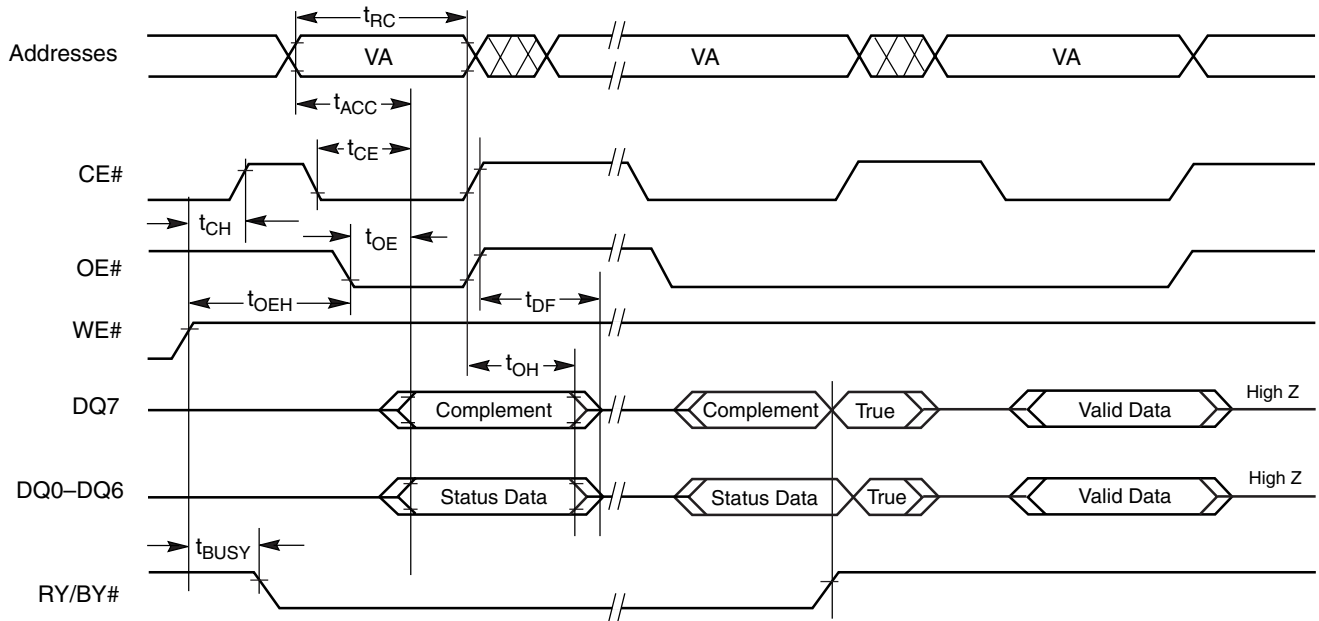

**Note:**

VA = Valid address. Illustration shows first status cycle after command sequence, last status read cycle, and array data read cycle.

**Figure 16. Data# Polling Timings (During Embedded Algorithms)**

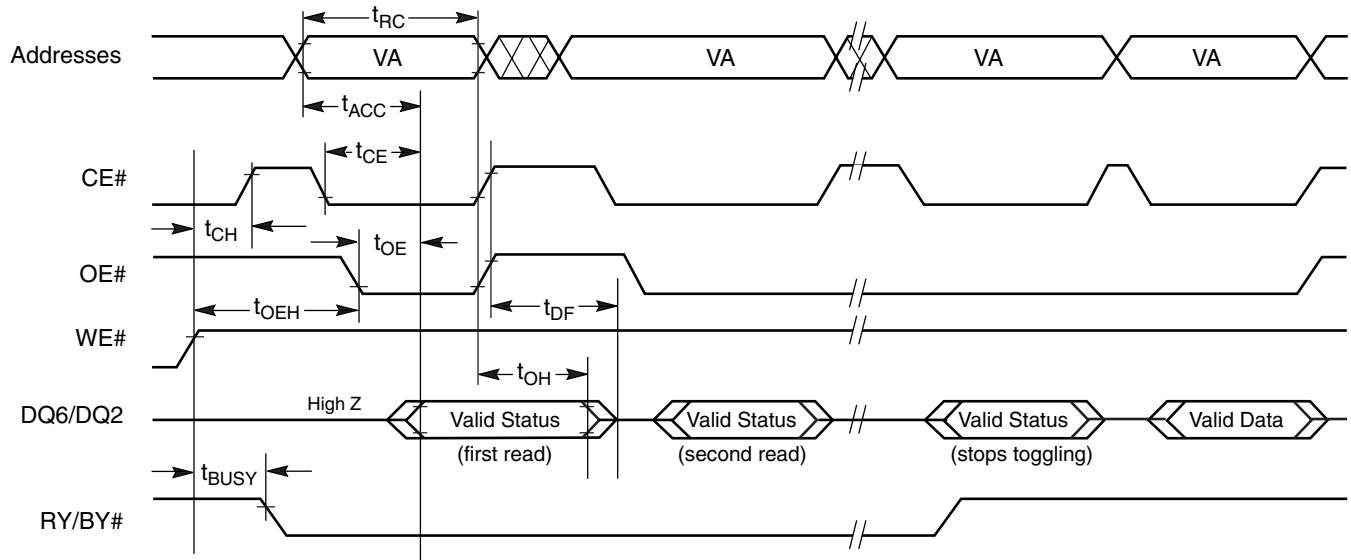

**Note:**

VA = Valid address; not required for DQ6. Illustration shows first two status cycle after command sequence, last status read cycle, and data read cycle.

**Figure 17. Toggle Bit Timings (During Embedded Algorithms)**

AC CHARACTERISTICS

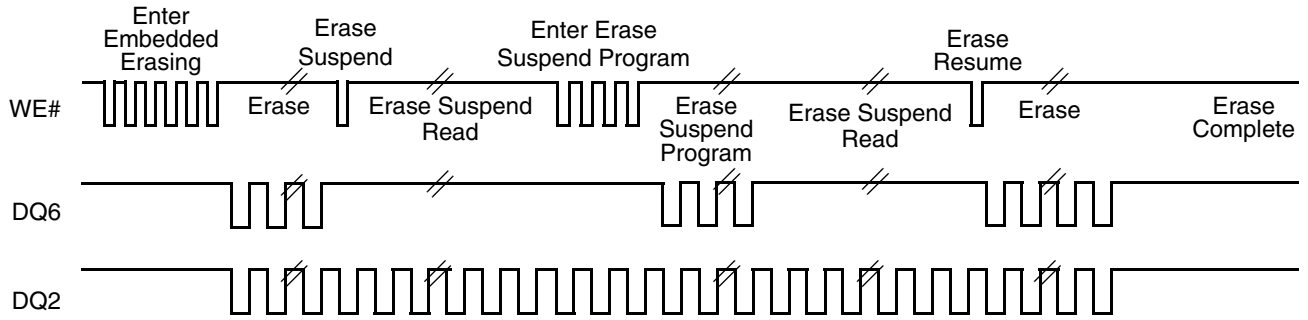

**Note:** The system may use OE# or CE# to toggle DQ2 and DQ6. DQ2 toggles only when read at an address within the erase-suspended sector.

Figure 18. DQ2 vs. DQ6

Temporary Sector Unprotect

Parameter		Description		All Speed Options	Unit
JEDEC	Std.				
	$t_{VIDR}$	$V_{ID}$ Rise and Fall Time (See Note)	Min	500	ns
	$t_{RSP}$	RESET# Setup Time for Temporary Sector Unprotect	Min	4	$\mu$ s

**Note:** Not 100% tested.

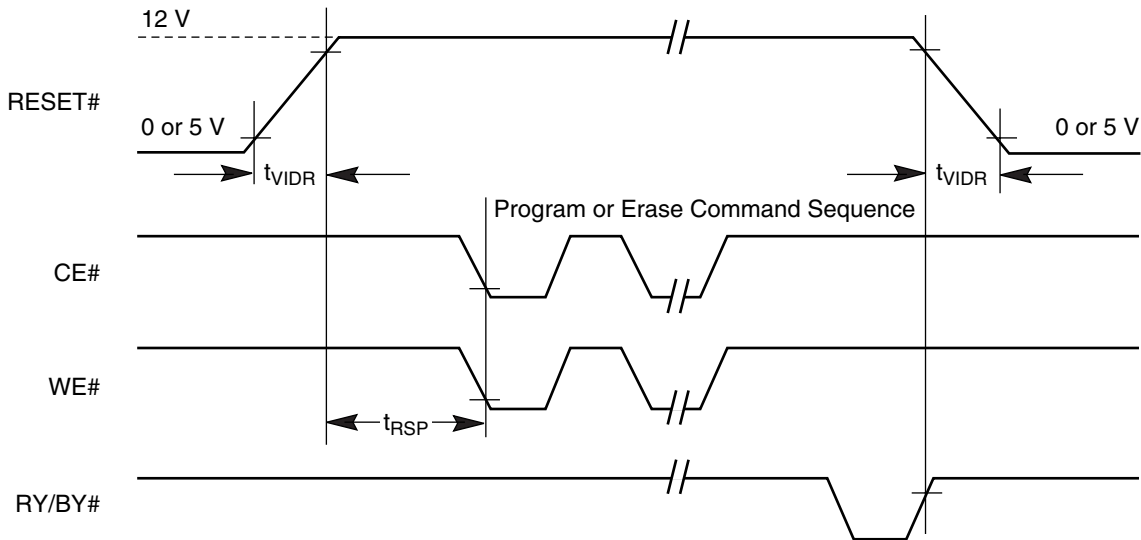
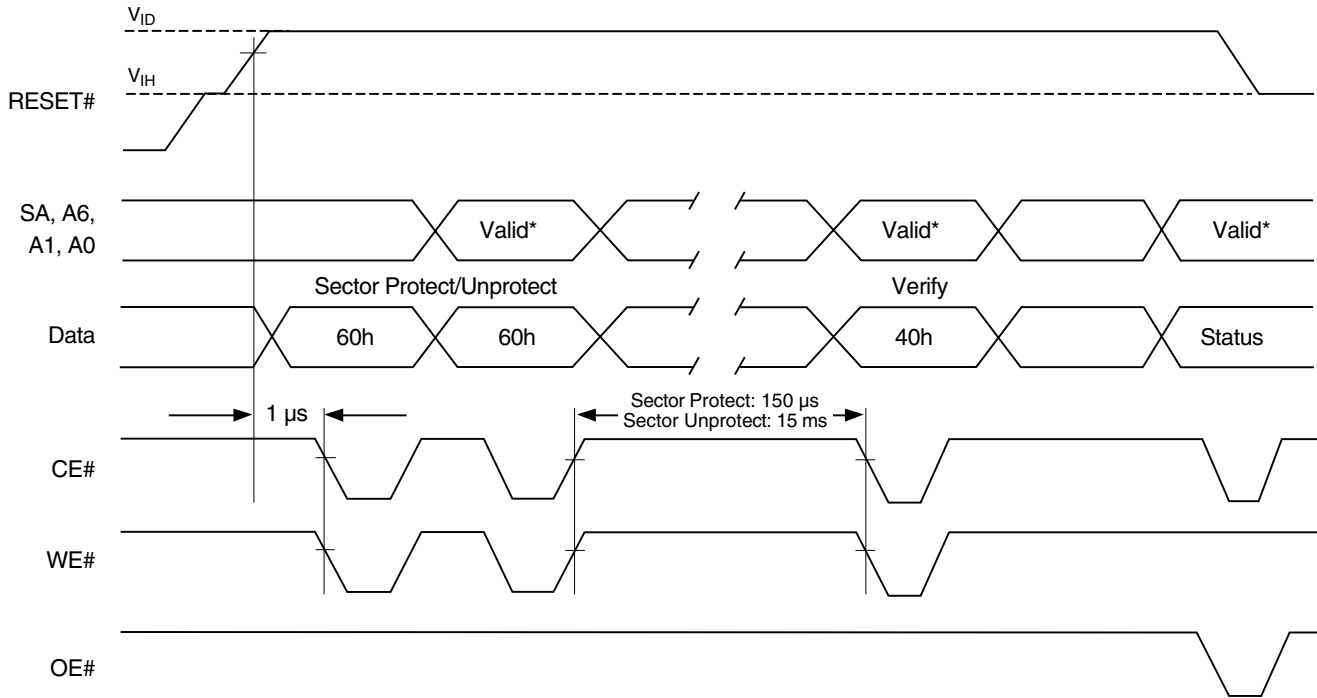

Figure 19. Temporary Sector Unprotect Timing Diagram



AC CHARACTERISTICS



**Note:** For sector protect,  $A6 = 0, A1 = 1, A0 = 0$ . For sector unprotect,  $A6 = 1, A1 = 1, A0 = 0$ .

**Figure 20. Sector Protect/Unprotect Timing Diagram**

## AC CHARACTERISTICS

## Alternate CE# Controlled Erase/Program Operations

Parameter		Description		Speed Options		Unit
JEDEC	Std.			70, 75	90	
$t_{AVAV}$	$t_{WC}$	Write Cycle Time (Note 1)	Min	70	90	ns
$t_{AVEL}$	$t_{AS}$	Address Setup Time	Min	0		ns
$t_{ELAX}$	$t_{AH}$	Address Hold Time	Min	45	45	ns
$t_{DVEH}$	$t_{DS}$	Data Setup Time	Min	30	45	ns
$t_{EHDX}$	$t_{DH}$	Data Hold Time	Min	0		ns
	$t_{OES}$	Output Enable Setup Time	Min	0		ns
$t_{GHEL}$	$t_{GHEL}$	Read Recovery Time Before Write (OE# High to WE# Low)	Min	0		ns
$t_{WLEL}$	$t_{WS}$	WE# Setup Time	Min	0		ns
$t_{EHWH}$	$t_{WH}$	WE# Hold Time	Min	0		ns
$t_{ELEH}$	$t_{CP}$	CE# Pulse Width	Min	35	45	ns
$t_{EHEL}$	$t_{CPH}$	CE# Pulse Width High	Min	20		ns
$t_{WHWH1}$	$t_{WHWH1}$	Programming Operation (Note 2)	Byte	Typ	7	$\mu$ s
			Word	Typ	12	
$t_{WHWH2}$	$t_{WHWH2}$	Sector Erase Operation (Note 2)	Typ	1		sec

**Notes:**

1. Not 100% tested.
2. See [Erase and Programming Performance, on page 42](#) for more information.

AC CHARACTERISTICS

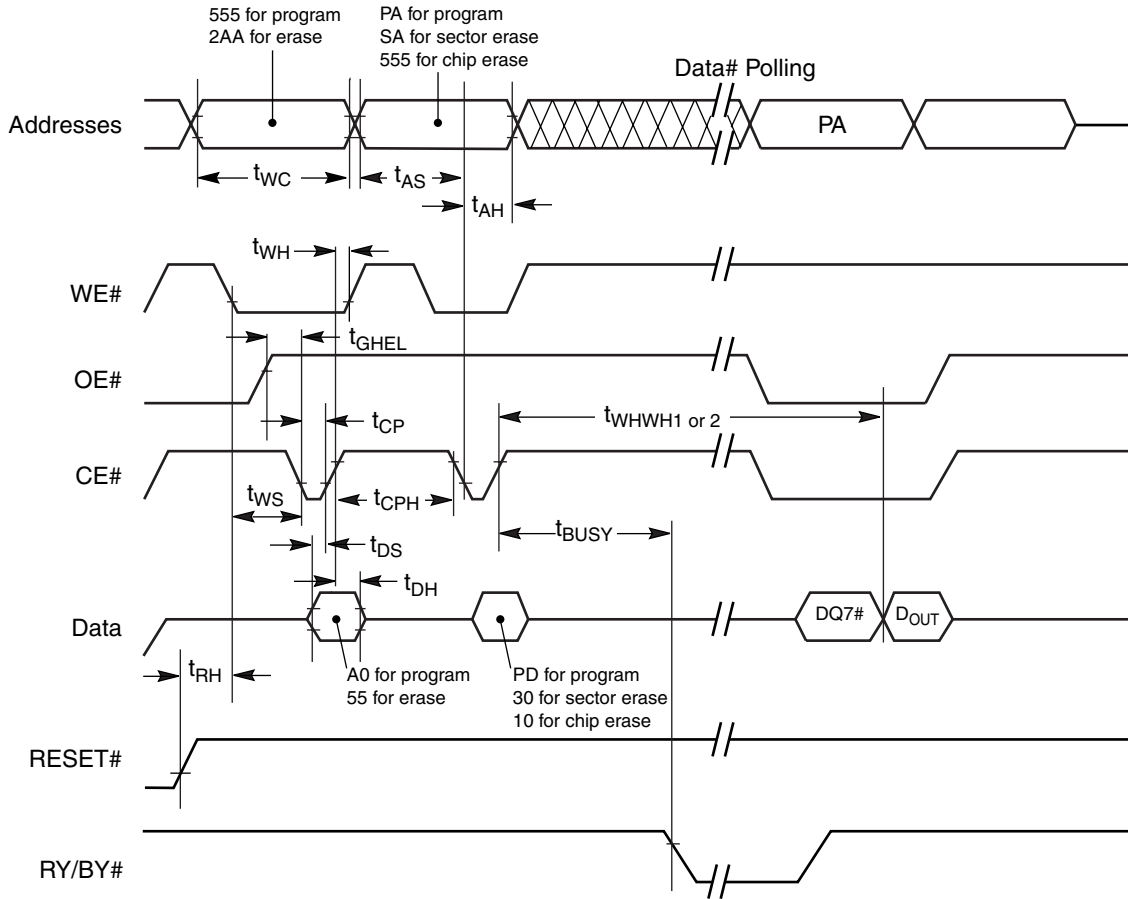

**Notes:**

1. PA = Program Address, PD = Program Data, SA = Sector Address, DQ7# = Complement of Data Input, D<sub>OUT</sub> = Array Data.
2. Figure indicates the last two bus cycles of the command sequence, with the device in word mode.

**Figure 21. Alternate CE# Controlled Write Operation Timings**

## ERASE AND PROGRAMMING PERFORMANCE

Parameter	Typ (Note 1)	Max (Note 3)	Unit	Comments
Sector Erase Time	1.0	8	s	Excludes 00h programming prior to erasure (Note 4)
Chip Erase Time (Note 2)	25		s	
Byte Programming Time	7	300	$\mu$ s	Excludes system level overhead (Note 5)
Word Programming Time	11	360	$\mu$ s	
Chip Programming Time (Note 2)	Byte Mode	15	s	
	Word Mode	12	s	

**Notes:**

1. Typical program and erase times assume the following conditions: 25°C, 5.0 V  $V_{CC}$ , 1,000,000 cycles. Additionally, programming typicals assume checkerboard pattern.
2. Under worst case conditions of 90°C,  $V_{CC} = 4.5$  V, 1,000,000 cycles.
3. The typical chip programming time is considerably less than the maximum chip programming time listed, since most bytes program faster than the maximum program times listed.
4. In the pre-programming step of the Embedded Erase algorithm, all bytes are programmed to 00h before erasure.
5. System-level overhead is the time required to execute the four-bus-cycle sequence for the program command. See Table 9 for further information on command definitions.
6. The device has a guaranteed minimum erase and program cycle endurance of 1,000,000 cycles.

## LATCHUP CHARACTERISTICS

Description	Min	Max
Input voltage with respect to $V_{SS}$ on all pins except I/O pins (including A9, OE#, and RESET#)	-1.0 V	12.5 V
Input voltage with respect to $V_{SS}$ on all I/O pins	-1.0 V	$V_{CC} + 1.0$ V
$V_{CC}$ Current	-100 mA	+100 mA

Includes all pins except  $V_{CC}$ . Test conditions:  $V_{CC} = 5.0$  V, one pin at a time.

## TSOP AND SO PIN CAPACITANCE

Parameter Symbol	Parameter Description	Test Setup	Typ	Max	Unit
$C_{IN}$	Input Capacitance	$V_{IN} = 0$	6	7.5	pF
$C_{OUT}$	Output Capacitance	$V_{OUT} = 0$	8.5	12	pF
$C_{IN2}$	Control Pin Capacitance	$V_{IN} = 0$	7.5	9	pF

**Notes:**

1. Sampled, not 100% tested.
2. Test conditions  $T_A = 25^\circ\text{C}$ ,  $f = 1.0$  MHz.

## DATA RETENTION

Parameter	Test Conditions	Min	Unit
Minimum Pattern Data Retention Time	150°C	10	Years
	125°C	20	Years

PHYSICAL DIMENSIONS

TS 048—48-Pin Standard Thin Small Outline Package

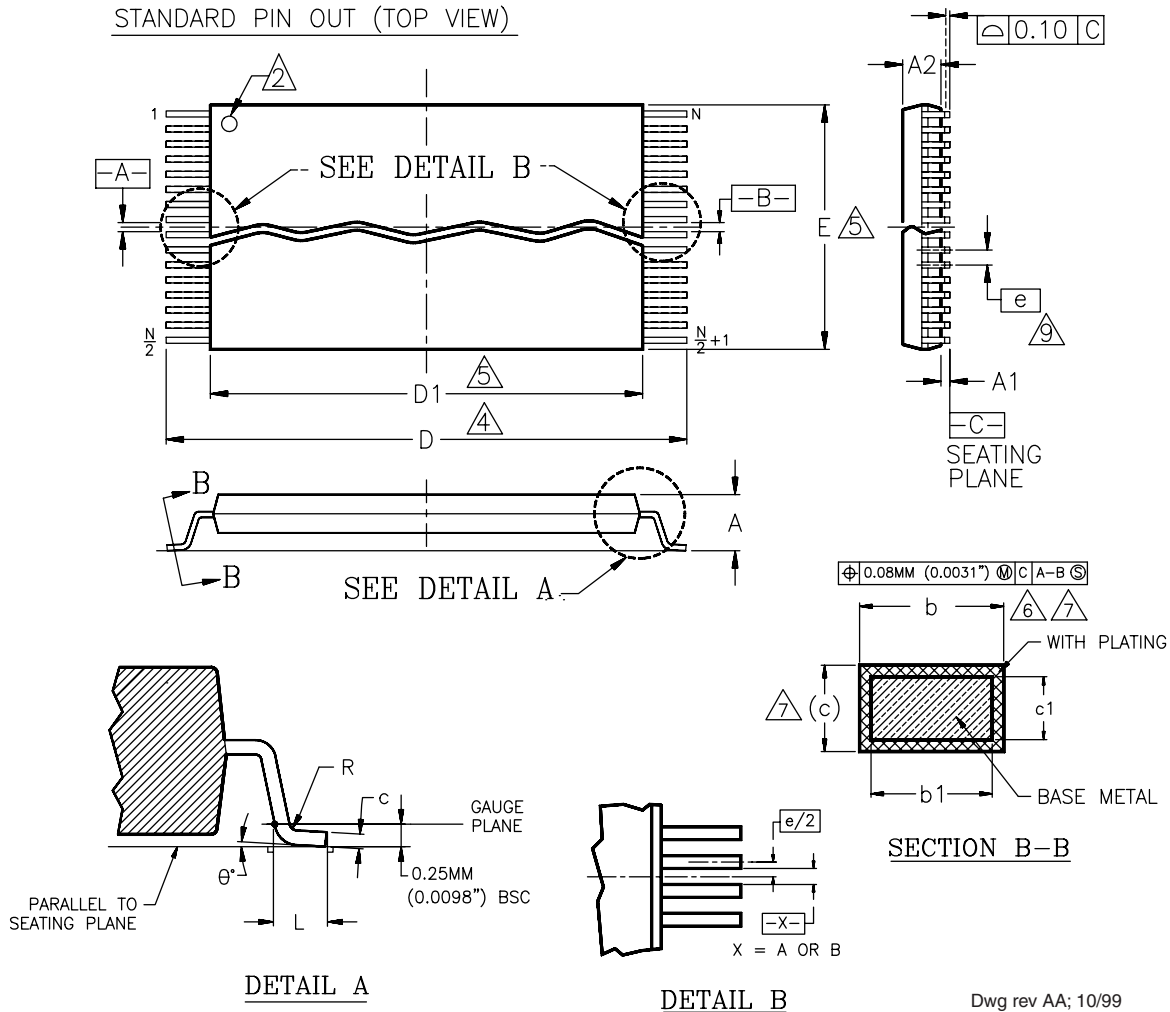

Dwg rev AA; 10/99

Package	TS 48		
Jedec	MO-142 (B) DD		
Symbol	MIN	NOM	MAX
A	—	—	1.20
A1	0.05	—	0.15
A2	0.95	1.00	1.05
b1	0.17	0.20	0.23
b	0.17	0.22	0.27
c1	0.10	—	0.16
c	0.10	—	0.21
D	19.80	20.00	20.20
D1	18.30	18.40	18.50
E	11.90	12.00	12.10
e	0.50 BASIC		
L	0.50	0.60	0.70
θ	0°	3°	5°
R	0.08	—	0.20
N	48		

NOTES:

1. CONTROLLING DIMENSIONS ARE IN MILLIMETERS (mm). (DIMENSIONING AND TOLERANCING CONFORMS TO ANSI Y14.5M-1982)
2. PIN 1 IDENTIFIER FOR STANDARD PIN OUT (DIE UP).
3. PIN 1 IDENTIFIER FOR REVERSE PIN OUT (DIE DOWN); INK OR LASER MARK.
4. TO BE DETERMINED AT THE SEATING PLANE  $\overline{C}$ . THE SEATING PLANE IS DEFINED AS THE PLANE OF CONTACT THAT IS MADE WHEN THE PACKAGE LEADS ARE ALLOWED TO REST FREELY ON A FLAT HORIZONTAL SURFACE.
5. DIMENSIONS D1 AND E DO NOT INCLUDE MOLD PROTRUSION. ALLOWABLE MOLD PROTRUSION IS 0.15mm (0.0059") PER SIDE.
6. DIMENSION b DOES NOT INCLUDE DAMBAR PROTRUSION. ALLOWABLE DAMBAR PROTRUSION SHALL BE 0.08mm (0.0031") TOTAL IN EXCESS OF b DIMENSION AT MAX. MATERIAL CONDITION. MINIMUM SPACE BETWEEN PROTRUSION AND AN ADJACENT LEAD TO BE 0.07mm (0.0028").
7. THESE DIMENSIONS APPLY TO THE FLAT SECTION OF THE LEAD BETWEEN 0.10mm (0.0039") AND 0.25mm (0.0098") FROM THE LEAD TIP.
8. LEAD COPLANARITY SHALL BE WITHIN 0.10mm (0.004") AS MEASURED FROM THE SEATING PLANE.
9. DIMENSION "e" IS MEASURED AT THE CENTERLINE OF THE LEADS.

**REVISION SUMMARY****Revision A (January 1999)**

Initial release.

**Revision B (June 14, 1999)****Global**

Expanded data sheet into document with full specifications.

Deleted the 55 ns speed options.

**Distinctive Characteristics**

In the Ultra Low Power Consumption bullets, changed the typical current to match the DC specifications (CMOS Compatible) table.

**Revision B+1 (July 7, 1999)****Connection Diagrams**

Corrected the signals on pins 39 and 40 of the reverse TSOP package.

**Revision B+2 (July 14, 1999)****Global**

Changed the  $V_{CC}$  operating range of the 70 ns speed option to  $5.0\text{ V} \pm 5\%$ . Deleted all references to uniform sector.

**Command Definitions table**

In Note 7, added a reference to CFI query mode.

**Revision B+3 (July 30, 1999)****Global**

Changed the part number designator for the 70 ns speed option to 75 (with  $V_{CC}$  rated at  $5.0\text{ V} \pm 5\%$ ).

**DC Characteristics**

*TTL/NMOS Compatible table*: Changed the maximum current specification for  $I_{CC2}$  to 50 mA.

**Revision B+4 (September 10, 1999)****Device Bus Operations**

*Write Protect (WP#)*: Clarified explanatory text.

**Command Definitions**

*Autoselect Command Sequence*: Added text and table explaining effect of WP# input on autoselect code output for 16 Kbyte boot sector.

**Revision C (November 16, 1999)****AC Characteristics—Figure 14. Program Operations Timing and Figure 15. Chip/Sector Erase Operations**

Deleted  $t_{GHWL}$  and changed OE# waveform to start at high.

**Physical Dimensions**

Replaced figures with more detailed illustrations.

**Revision D (December 4, 2000)**

Removed Advance Information status from document.

**Ordering Information**

Deleted optional processing.

**Table 9, Command Definitions**

In Note 5, changed the lower address bit in don't care range to A11.

**Table 11, Test Specifications**

Changed capacitive loading on 70 ns speed option to 30 pF.

**Revision D+1 (November 18, 2003)****Global**

Added "70" speed option (70 ns,  $V_{CC} = 5.0\text{ V} \pm 10\%$ ).

**Revision D+2 (October 29, 2004)**

Added Pb-Free option.

**Revision D+3 (April 4, 2005)****Distinctive Characteristics**

Changed  $\mu\text{m}$  process technology number.

Changed terminology in WP# input pin description.

**Global**

Changed WP# terminology throughout the data sheet.

**Revision D4 (December 23, 2005)****Global**

Deleted reverse TSOP package option and 120 ns speed option.

**Revision D5 (May 19, 2006)**

Added "Not recommended for new designs" note.

**AC Characteristics**

Changed  $t_{BUSY}$  specification to maximum value.

**Revision D6 (November 2, 2006)**

Deleted "Not recommended for new designs" note.

**Revision D7 (March 5, 2009)****Global**

Added obsolescence information.

**Revision D8 (August 3, 2009)****Global**

Removed obsolescence information.

***Colophon***

The products described in this document are designed, developed and manufactured as contemplated for general use, including without limitation, ordinary industrial use, general office use, personal use, and household use, but are not designed, developed and manufactured as contemplated (1) for any use that includes fatal risks or dangers that, unless extremely high safety is secured, could have a serious effect to the public, and could lead directly to death, personal injury, severe physical damage or other loss (i.e., nuclear reaction control in nuclear facility, aircraft flight control, air traffic control, mass transport control, medical life support system, missile launch control in weapon system), or (2) for any use where chance of failure is intolerable (i.e., submersible repeater and artificial satellite). Please note that Spansion will not be liable to you and/or any third party for any claims or damages arising in connection with above-mentioned uses of the products. Any semiconductor devices have an inherent chance of failure. You must protect against injury, damage or loss from such failures by incorporating safety design measures into your facility and equipment such as redundancy, fire protection, and prevention of over-current levels and other abnormal operating conditions. If any products described in this document represent goods or technologies subject to certain restrictions on export under the Foreign Exchange and Foreign Trade Law of Japan, the US Export Administration Regulations or the applicable laws of any other country, the prior authorization by the respective government entity will be required for export of those products.

***Trademarks and Notice***

The contents of this document are subject to change without notice. This document may contain information on a Spansion product under development by Spansion. Spansion reserves the right to change or discontinue work on any product without notice. The information in this document is provided as is without warranty or guarantee of any kind as to its accuracy, completeness, operability, fitness for particular purpose, merchantability, non-infringement of third-party rights, or any other warranty, express, implied, or statutory. Spansion assumes no liability for any damages of any kind arising out of the use of the information in this document.

Copyright © 1999–2005 Advanced Micro Devices, Inc. All rights reserved. AMD, the AMD logo, and combinations thereof are registered trademarks of Advanced Micro Devices, Inc. Product names used in this publication are for identification purposes only and may be trademarks of their respective companies.

Copyright © 2006–2009 Spansion Inc. All rights reserved. Spansion®, the Spansion logo, MirrorBit®, MirrorBit® Eclipse™, ORNAND™, EcoRAM™ and combinations thereof, are trademarks and registered trademarks of Spansion LLC in the United States and other countries. Other names used are for informational purposes only and may be trademarks of their respective owners.