



# LPC2458

Single-chip 16-bit/32-bit micro; 512 kB flash, Ethernet, CAN, ISP/IAP, USB 2.0 device/host/OTG, external memory interface

Rev. 02 — 25 November 2008

Product data sheet

## 1. General description

---

NXP Semiconductors designed the LPC2458 microcontroller around a 16-bit/32-bit ARM7TDMI-S CPU core with real-time debug interfaces that include both JTAG and embedded trace. The LPC2458 has 512 kB of on-chip high-speed flash memory. This flash memory includes a special 128-bit wide memory interface and accelerator architecture that enables the CPU to execute sequential instructions from flash memory at the maximum 72 MHz system clock rate. This feature is available only on the LPC2000 ARM microcontroller family of products. The LPC2458 can execute both 32-bit ARM and 16-bit Thumb instructions. Support for the two instruction sets means engineers can choose to optimize their application for either performance or code size at the sub-routine level. When the core executes instructions in Thumb state it can reduce code size by more than 30 % with only a small loss in performance while executing instructions in ARM state maximizes core performance.

The LPC2458 microcontroller is ideal for multi-purpose communication applications. It incorporates a 10/100 Ethernet Media Access Controller (MAC), a USB full-speed Device/Host/OTG Controller with 4 kB of endpoint RAM, four UARTs, two Controller Area Network (CAN) channels, an SPI interface, two Synchronous Serial Ports (SSP), three I<sup>2</sup>C interfaces, and an I<sup>2</sup>S interface. Supporting this collection of serial communications interfaces are the following feature components; an on-chip 4 MHz internal precision oscillator, 98 kB of total RAM consisting of 64 kB of local SRAM, 16 kB SRAM for Ethernet, 16 kB SRAM for general purpose DMA, 2 kB of battery powered SRAM, and an External Memory Controller (EMC). These features make this device optimally suited for communication gateways and protocol converters. Complementing the many serial communication controllers, versatile clocking capabilities, and memory features are various 32-bit timers, an improved 10-bit ADC, 10-bit DAC, two PWM units, four external interrupt pins, and up to 136 fast GPIO lines. The LPC2458 connects 64 of the GPIO pins to the hardware based Vector Interrupt Controller (VIC) that means these external inputs can generate edge-triggered interrupts. All of these features make the LPC2458 particularly suitable for industrial control and medical systems.

## 2. Features

---

- ARM7TDMI-S processor, running at up to 72 MHz.
- 512 kB on-chip flash program memory with In-System Programming (ISP) and In-Application Programming (IAP) capabilities. Flash program memory is on the ARM local bus for high performance CPU access.
- 98 kB on-chip SRAM includes:
  - ◆ 64 kB of SRAM on the ARM local bus for high performance CPU access.
  - ◆ 16 kB SRAM for Ethernet interface. Can also be used as general purpose SRAM.

- ◆ 16 kB SRAM for general purpose DMA use also accessible by the USB.
- ◆ 2 kB SRAM data storage powered from the Real-Time Clock (RTC) power domain.
- Dual Advanced High-performance Bus (AHB) system allows simultaneous Ethernet DMA, USB DMA, and program execution from on-chip flash with no contention.
- EMC provides support for asynchronous static memory devices such as RAM, ROM and flash, as well as dynamic memories such as Single Data Rate SDRAM.
- Advanced Vectored Interrupt Controller (VIC), supporting up to 32 vectored interrupts.
- General Purpose DMA controller (GPDMA) on AHB that can be used with the SSP, I<sup>2</sup>S, and SD/MM interface as well as for memory-to-memory transfers.
- Serial Interfaces:
  - ◆ Ethernet MAC with MII/RMII interface and associated DMA controller. These functions reside on an independent AHB.
  - ◆ USB 2.0 full-speed dual port Device/Host/OTG Controller with on-chip PHY and associated DMA controller.
  - ◆ Four UARTs with fractional baud rate generation, one with modem control I/O, one with IrDA support, all with FIFO.
  - ◆ CAN controller with two channels.
  - ◆ SPI controller.
  - ◆ Two SSP controllers, with FIFO and multi-protocol capabilities. One is an alternate for the SPI port, sharing its interrupt. SSPs can be used with the GPDMA controller.
  - ◆ Three I<sup>2</sup>C-bus interfaces (one with open-drain and two with standard port pins).
  - ◆ I<sup>2</sup>S (Inter-IC Sound) interface for digital audio input or output. It can be used with the GPDMA.
- Other peripherals:
  - ◆ SD/MMC memory card interface.
  - ◆ 136 General purpose I/O pins with configurable pull-up/down resistors.
  - ◆ 10-bit ADC with input multiplexing among 8 pins.
  - ◆ 10-bit DAC.
  - ◆ Four general purpose timers/counters with 8 capture inputs and 10 compare outputs. Each timer block has an external count input.
  - ◆ Two PWM/timer blocks with support for three-phase motor control. Each PWM has an external count inputs.
  - ◆ RTC with separate power domain, clock source can be the RTC oscillator or the APB clock.
  - ◆ 2 kB SRAM powered from the RTC power pin, allowing data to be stored when the rest of the chip is powered off.
  - ◆ WatchDog Timer (WDT). The WDT can be clocked from the internal RC oscillator, the RTC oscillator, or the APB clock.
- Standard ARM test/debug interface for compatibility with existing tools.
- Emulation trace module supports real-time trace.
- Single 3.3 V power supply (3.0 V to 3.6 V).
- Three reduced power modes: idle, sleep, and power-down.
- Four external interrupt inputs configurable as edge/level sensitive. All pins on port 0 and port 2 can be used as edge sensitive interrupt sources.

- Processor wake-up from Power-down mode via any interrupt able to operate during Power-down mode (includes external interrupts, RTC interrupt, USB activity, Ethernet wake-up interrupt, CAN bus activity, port 0/2 pin interrupt).
- Two independent power domains allow fine tuning of power consumption based on needed features.
- Each peripheral has its own clock divider for further power saving. These dividers help reducing active power by 20 % to 30 %.
- Brownout detect with separate thresholds for interrupt and forced reset.
- On-chip power-on reset.
- On-chip crystal oscillator with an operating range of 1 MHz to 25 MHz.
- 4 MHz internal RC oscillator trimmed to 1 % accuracy that can optionally be used as the system clock. When used as the CPU clock, does not allow CAN and USB to run.
- On-chip PLL allows CPU operation up to the maximum CPU rate without the need for a high frequency crystal. May be run from the main oscillator, the internal RC oscillator, or the RTC oscillator.
- Boundary scan for simplified board testing.
- Versatile pin function selections allow more possibilities for using on-chip peripheral functions.

### 3. Applications

- Industrial control
- Medical systems
- Protocol converter
- Communications

### 4. Ordering information

Table 1. Ordering information

| Type number   | Package  |                                                                           |          |
|---------------|----------|---------------------------------------------------------------------------|----------|
|               | Name     | Description                                                               | Version  |
| LPC2458FET180 | TFBGA180 | thin fine-pitch ball grid array package; 180 balls; body 12 × 12 × 0.8 mm | SOT570-2 |

#### 4.1 Ordering options

Table 2. Ordering options

| Type number   | Flash (kB) | SRAM (kB) |                 |        |     |       | External bus | Ethernet | USB OTG/OHC/DEV + 4 kB FIFO | CAN channels | SD/MMC | GP DMA | ADC channels | DAC channels | Temp range       |
|---------------|------------|-----------|-----------------|--------|-----|-------|--------------|----------|-----------------------------|--------------|--------|--------|--------------|--------------|------------------|
|               |            | Local bus | Ethernet buffer | GP/USB | RTC | Total |              |          |                             |              |        |        |              |              |                  |
| LPC2458FET180 | 512        | 64        | 16              | 16     | 2   | 98    | 16-bit       | MII/RMII | yes                         | 2            | yes    | yes    | 8            | 1            | -40 °C to +85 °C |

5. Block diagram

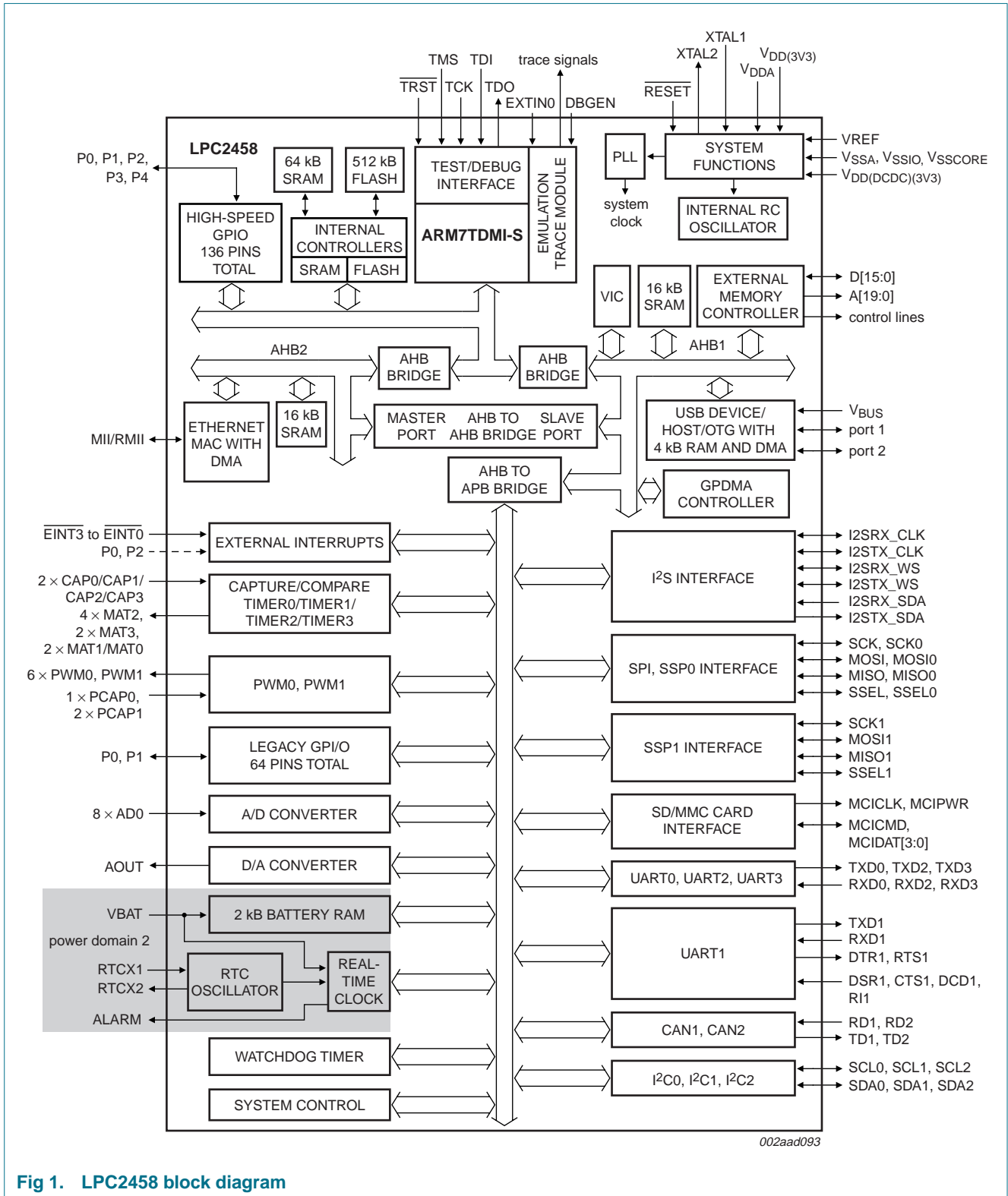

Fig 1. LPC2458 block diagram

## 6. Pinning information

### 6.1 Pinning

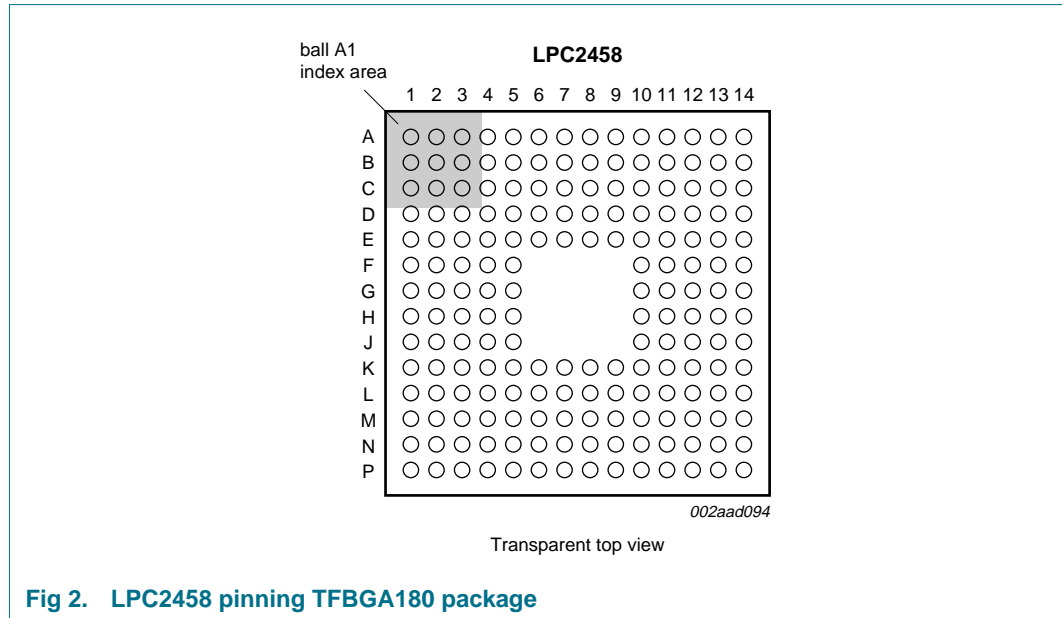

Fig 2. LPC2458 pinning TFBGA180 package

Table 3. Pin allocation table

| Pin          | Symbol                              | Pin | Symbol                                | Pin | Symbol                             | Pin | Symbol                                  |
|--------------|-------------------------------------|-----|---------------------------------------|-----|------------------------------------|-----|-----------------------------------------|
| <b>Row A</b> |                                     |     |                                       |     |                                    |     |                                         |
| 1            | P3[12]/D12                          | 2   | P3[2]/D2                              | 3   | P0[3]/RXD0                         | 4   | P3[9]/D9                                |
| 5            | P1[1]/ENET_TXD1                     | 6   | P3[8]/D8                              | 7   | P1[10]/ENET_RXD1                   | 8   | P1[15]/<br>ENET_REF_CLK/<br>ENET_RX_CLK |
| 9            | P1[3]/ENET_TXD3/<br>MCICMD/PWM0[2]  | 10  | V <sub>SSCORE</sub>                   | 11  | P0[4]/I2SRX_CLK/RD2/<br>CAP2[0]    | 12  | P1[11]/ENET_RXD2/<br>MCIDAT2/PWM0[6]    |
| 13           | P0[9]/I2STX_SDA/<br>MOSI1/MAT2[3]   | 14  | P1[12]/ENET_RXD3/<br>MCIDAT3/PCAP0[0] | 15  | -                                  | 16  | -                                       |
| <b>Row B</b> |                                     |     |                                       |     |                                    |     |                                         |
| 1            | TDO                                 | 2   | P3[11]/D11                            | 3   | P3[10]/D10                         | 4   | V <sub>SSIO</sub>                       |
| 5            | P1[0]/ENET_TXD0                     | 6   | P1[8]/ENET_CRD_DV/E<br>NET_CRD        | 7   | P1[2]/ENET_TXD2/<br>MCICLK/PWM0[1] | 8   | P1[16]/ENET_MDC                         |
| 9            | P4[29]/<br>MAT2[1]/RXD3             | 10  | P1[6]/ENET_TX_CLK/<br>MCIDAT0/PWM0[4] | 11  | P0[5]/I2SRX_WS/TD2/<br>CAP2[1]     | 12  | P0[7]/I2STX_CLK/SCK1<br>/MAT2[1]        |
| 13           | P1[5]/ENET_TX_ER/<br>MCIPWR/PWM0[3] | 14  | P4[13]/A13                            | 15  | -                                  | 16  | -                                       |
| <b>Row C</b> |                                     |     |                                       |     |                                    |     |                                         |
| 1            | P3[13]/D13                          | 2   | TMS                                   | 3   | TDI                                | 4   | RTCK                                    |
| 5            | V <sub>DD(3V3)</sub>                | 6   | P1[4]/ENET_TX_EN                      | 7   | P4[30]/CS0                         | 8   | P4[24]/OE                               |
| 9            | P1[17]/ENET_MDIO                    | 10  | P4[15]/A15                            | 11  | V <sub>SSIO</sub>                  | 12  | P0[8]/I2STX_WS/<br>MISO1/MAT2[2]        |

Table 3. Pin allocation table ...continued

| Pin          | Symbol                              | Pin | Symbol                           | Pin | Symbol                                 | Pin | Symbol                            |
|--------------|-------------------------------------|-----|----------------------------------|-----|----------------------------------------|-----|-----------------------------------|
| 13           | P1[7]/ENET_COL/<br>MCIDAT1/PWM0[5]  | 14  | P2[1]/PWM1[2]/RXD1/<br>PIPESTAT0 | 15  | -                                      | 16  | -                                 |
| <b>Row D</b> |                                     |     |                                  |     |                                        |     |                                   |
| 1            | P0[26]/AD0[3]/<br>AOUT/RXD3         | 2   | TCK                              | 3   | P3[4]/D4                               | 4   | TRST                              |
| 5            | P0[2]/TXD0                          | 6   | P3[0]/D0                         | 7   | P1[9]/ENET_RXD0                        | 8   | P1[14]/ENET_RX_ER                 |
| 9            | P4[25]/ $\overline{WE}$             | 10  | P4[28]/<br>MAT2[0]/TXD3          | 11  | P0[6]/I2SRX_SDA/<br>SSEL1/MAT2[0]      | 12  | P2[0]/PWM1[1]/TXD1/<br>TRACECLK   |
| 13           | V <sub>SSIO</sub>                   | 14  | P1[13]/ENET_RX_DV                | 15  | -                                      | 16  | -                                 |
| <b>Row E</b> |                                     |     |                                  |     |                                        |     |                                   |
| 1            | P0[24]/AD0[1]/<br>I2SRX_WS/CAP3[1]  | 2   | V <sub>DD(3V3)</sub>             | 3   | P3[5]/D5                               | 4   | P0[25]/AD0[2]/<br>I2SRX_SDA/TXD3  |
| 5            | DBGEN                               | 6   | P3[1]/D1                         | 7   | P4[31]/ $\overline{CS1}$               | 8   | P4[14]/A14                        |
| 9            | V <sub>DD(DCDC)(3V3)</sub>          | 10  | V <sub>DD(3V3)</sub>             | 11  | P2[2]/PWM1[3]/<br>CTS1/PIPESTAT1       | 12  | V <sub>DD(3V3)</sub>              |
| 13           | P2[3]/PWM1[4]/<br>DCD1/PIPESTAT2    | 14  | P2[4]/PWM1[5]/<br>DSR1/TRACESYNC | 15  | -                                      | 16  | -                                 |
| <b>Row F</b> |                                     |     |                                  |     |                                        |     |                                   |
| 1            | P3[14]/D14                          | 2   | V <sub>DDA</sub>                 | 3   | V <sub>SSA</sub>                       | 4   | P3[6]/D6                          |
| 5            | P0[23]/AD0[0]/<br>I2SRX_CLK/CAP3[0] | 6   |                                  | 7   |                                        | 8   |                                   |
| 9            |                                     | 10  | P4[12]/A12                       | 11  | P4[11]/A11                             | 12  | P2[5]/PWM1[6]/<br>DTR1/TRACEPKT0  |
| 13           | P2[6]/PCAP1[0]/<br>RI1/TRACEPKT1    | 14  | P4[27]/ $\overline{BLS1}$        | 15  | -                                      | 16  | -                                 |
| <b>Row G</b> |                                     |     |                                  |     |                                        |     |                                   |
| 1            | V <sub>DD(DCDC)(3V3)</sub>          | 2   | VREF                             | 3   | P3[7]/D7                               | 4   | P3[15]/D15                        |
| 5            | P3[3]/D3                            | 6   |                                  | 7   |                                        | 8   |                                   |
| 9            |                                     | 10  | n.c.                             | 11  | P2[7]/RD2/<br>RTS1/TRACEPKT2           | 12  | P4[10]/A10                        |
| 13           | V <sub>SSIO</sub>                   | 14  | P2[8]/TD2/<br>TXD2/TRACEPKT3     | 15  | -                                      | 16  | -                                 |
| <b>Row H</b> |                                     |     |                                  |     |                                        |     |                                   |
| 1            | n.c.                                | 2   | RSTOUT                           | 3   | V <sub>SSCORE</sub>                    | 4   | V <sub>SSIO</sub>                 |
| 5            | ALARM                               | 6   |                                  | 7   |                                        | 8   |                                   |
| 9            |                                     | 10  | P4[5]/A5                         | 11  | P2[9]/<br>USB_CONNECT1/<br>RXD2/EXTIN0 | 12  | P4[9]/A9                          |
| 13           | P0[15]/TXD1/<br>SCK0/SCK            | 14  | P0[16]/RXD1/<br>SSEL0/SSEL       | 15  | -                                      | 16  | -                                 |
| <b>Row J</b> |                                     |     |                                  |     |                                        |     |                                   |
| 1            | $\overline{RESET}$                  | 2   | RTCX1                            | 3   | RTCX2                                  | 4   | P0[12]/USB_PPWR2/<br>MISO1/AD0[6] |
| 5            | P0[13]/USB_UP_LED2/<br>MOS11/AD0[7] | 6   |                                  | 7   |                                        | 8   |                                   |

Table 3. Pin allocation table ...continued

| Pin          | Symbol                                       | Pin | Symbol                                                  | Pin | Symbol                                                   | Pin | Symbol                                                   |
|--------------|----------------------------------------------|-----|---------------------------------------------------------|-----|----------------------------------------------------------|-----|----------------------------------------------------------|
| 9            |                                              | 10  | P0[19]/DSR1/<br>MCICLK/SDA1                             | 11  | P4[8]/A8                                                 | 12  | P0[17]/CTS1/<br>MISO0/MISO                               |
| 13           | P0[18]/DCD1/<br>MOSI0/MOSI                   | 14  | V <sub>DD(3V3)</sub>                                    | 15  | -                                                        | 16  | -                                                        |
| <b>Row K</b> |                                              |     |                                                         |     |                                                          |     |                                                          |
| 1            | VBAT                                         | 2   | P1[31]/USB_OVRCR2/<br>SCK1/AD0[5]                       | 3   | P1[30]/USB_PWRD2/<br>V <sub>BUS</sub> /AD0[4]            | 4   | XTAL2                                                    |
| 5            | P0[29]/USB_D+1                               | 6   | P1[20]/USB_TX_DP1/<br>PWM1[2]/SCK0                      | 7   | P3[26]/MAT0[1]/<br>PWM1[3]                               | 8   | V <sub>DD(3V3)</sub>                                     |
| 9            | P4[3]/A3                                     | 10  | P4[6]/A6                                                | 11  | P0[21]/R11/<br>MCIPWR/RD1                                | 12  | P4[7]/A7                                                 |
| 13           | P4[26]/ $\overline{\text{BLS0}}$             | 14  | P0[20]/DTR1/<br>MCICMD/SCL1                             | 15  | -                                                        | 16  | -                                                        |
| <b>Row L</b> |                                              |     |                                                         |     |                                                          |     |                                                          |
| 1            | P2[29]/DQMOUT1                               | 2   | XTAL1                                                   | 3   | P0[27]/SDA0                                              | 4   | V <sub>DD(3V3)</sub>                                     |
| 5            | P1[18]/USB_UP_LED1/<br>PWM1[1]/CAP1[0]       | 6   | P4[0]/A0                                                | 7   | P1[25]/USB_LS1/<br>USB_HSTEN1/MAT1[1]                    | 8   | V <sub>SSCORE</sub>                                      |
| 9            | V <sub>SSIO</sub>                            | 10  | P0[10]/TXD2/SDA2/<br>MAT3[0]                            | 11  | V <sub>DD(3V3)</sub>                                     | 12  | n.c.                                                     |
| 13           | V <sub>SSIO</sub>                            | 14  | P0[22]/RTS1/<br>MCIDAT0/TD1                             | 15  | -                                                        | 16  | -                                                        |
| <b>Row M</b> |                                              |     |                                                         |     |                                                          |     |                                                          |
| 1            | P0[28]/SCL0                                  | 2   | P2[28]/DQMOUT0                                          | 3   | P3[25]/MAT0[0]/<br>PWM1[2]                               | 4   | P3[23]/CAP0[0]/<br>PCAP1[0]                              |
| 5            | P0[14]/USB_HSTEN2/<br>USB_CONNECT2/<br>SSEL1 | 6   | P1[22]/USB_RCV1/<br>USB_PWRD1/MAT1[0]                   | 7   | P4[1]/A1                                                 | 8   | P4[2]/A2                                                 |
| 9            | P1[27]/USB_INT1/<br>USB_OVRCR1/CAP0[1]       | 10  | P0[0]/RD1/TXD3/SDA1                                     | 11  | P2[13]/ $\overline{\text{EINT3}}$ /<br>MCIDAT3/I2STX_SDA | 12  | P2[11]/ $\overline{\text{EINT1}}$ /<br>MCIDAT1/I2STX_CLK |
| 13           | P2[10]/ $\overline{\text{EINT0}}$            | 14  | P4[19]/A19                                              | 15  | -                                                        | 16  | -                                                        |
| <b>Row N</b> |                                              |     |                                                         |     |                                                          |     |                                                          |
| 1            | P0[31]/USB_D+2                               | 2   | USB_D-2                                                 | 3   | P3[24]/CAP0[1]/<br>PWM1[1]                               | 4   | P0[30]/USB_D-1                                           |
| 5            | P2[19]/CLKOUT1                               | 6   | P1[21]/USB_TX_DM1/<br>PWM1[3]/SSEL0                     | 7   | P1[23]/USB_RX_DP1/<br>PWM1[4]/MISO0                      | 8   | P2[21]/ $\overline{\text{DYCS1}}$                        |
| 9            | V <sub>DD(DCDC)(3V3)</sub>                   | 10  | P1[29]/USB_SDA1/<br>PCAP1[1]/MAT0[1]                    | 11  | P0[1]/TD1/RXD3/SCL1                                      | 12  | P4[16]/A16                                               |
| 13           | P4[17]/A17                                   | 14  | P2[12]/ $\overline{\text{EINT2}}$ /<br>MCIDAT2/I2STX_WS | 15  | -                                                        | 16  | -                                                        |
| <b>Row P</b> |                                              |     |                                                         |     |                                                          |     |                                                          |
| 1            | P2[24]/CKEOUT0                               | 2   | P2[25]/CKEOUT1                                          | 3   | P2[18]/CLKOUT0                                           | 4   | V <sub>SSIO</sub>                                        |
| 5            | P1[19]/USB_TX_E1/<br>USB_PPWR1/CAP1[1]       | 6   | P2[20]/ $\overline{\text{DYCS0}}$                       | 7   | P1[24]/USB_RX_DM1/<br>PWM1[5]/MOSI0                      | 8   | P1[26]/USB_SSPND1/<br>PWM1[6]/CAP0[0]                    |
| 9            | P2[16]/ $\overline{\text{CAS}}$              | 10  | P1[28]/USB_SCL1/<br>PCAP1[0]/MAT0[0]                    | 11  | P2[17]/ $\overline{\text{RAS}}$                          | 12  | P0[11]/RXD2/SCL2/<br>MAT3[1]                             |
| 13           | P4[4]/A4                                     | 14  | P4[18]/A18                                              | 15  | -                                                        | 16  | -                                                        |

## 6.2 Pin description

Table 4. Pin description

| Symbol                                | Ball               | Type | Description                                                                                                                                                                                |
|---------------------------------------|--------------------|------|--------------------------------------------------------------------------------------------------------------------------------------------------------------------------------------------|
| P0[0] to P0[31]                       |                    | I/O  | <b>Port 0:</b> Port 0 is a 32-bit I/O port with individual direction controls for each bit. The operation of port 0 pins depends upon the pin function selected via the Pin Connect block. |
| P0[0]/RD1/<br>TXD3/SDA1               | M10 <sup>[1]</sup> | I/O  | <b>P0[0]</b> — General purpose digital input/output pin.                                                                                                                                   |
|                                       |                    | I    | <b>RD1</b> — CAN1 receiver input.                                                                                                                                                          |
|                                       |                    | O    | <b>TXD3</b> — Transmitter output for UART3.                                                                                                                                                |
|                                       |                    | I/O  | <b>SDA1</b> — I <sup>2</sup> C1 data input/output (this is not an open-drain pin).                                                                                                         |
| P0[1]/TD1/RXD3/<br>SCL1               | N11 <sup>[1]</sup> | I/O  | <b>P0[1]</b> — General purpose digital input/output pin.                                                                                                                                   |
|                                       |                    | O    | <b>TD1</b> — CAN1 transmitter output.                                                                                                                                                      |
|                                       |                    | I    | <b>RXD3</b> — Receiver input for UART3.                                                                                                                                                    |
|                                       |                    | I/O  | <b>SCL1</b> — I <sup>2</sup> C1 clock input/output (this is not an open-drain pin).                                                                                                        |
| P0[2]/TXD0                            | D5 <sup>[1]</sup>  | I/O  | <b>P0[2]</b> — General purpose digital input/output pin.                                                                                                                                   |
|                                       |                    | O    | <b>TXD0</b> — Transmitter output for UART0.                                                                                                                                                |
| P0[3]/RXD0                            | A3 <sup>[1]</sup>  | I/O  | <b>P0[3]</b> — General purpose digital input/output pin.                                                                                                                                   |
|                                       |                    | I    | <b>RXD0</b> — Receiver input for UART0.                                                                                                                                                    |
| P0[4]/<br>I2SRX_CLK/<br>RD2/CAP2[0]   | A11 <sup>[1]</sup> | I/O  | <b>P0[4]</b> — General purpose digital input/output pin.                                                                                                                                   |
|                                       |                    | I/O  | <b>I2SRX_CLK</b> — Receive Clock. It is driven by the master and received by the slave. Corresponds to the signal SCK in the I <sup>2</sup> S-bus specification.                           |
|                                       |                    | I    | <b>RD2</b> — CAN2 receiver input.                                                                                                                                                          |
|                                       |                    | I    | <b>CAP2[0]</b> — Capture input for Timer 2, channel 0.                                                                                                                                     |
| P0[5]/<br>I2SRX_WS/<br>TD2/CAP2[1]    | B11 <sup>[1]</sup> | I/O  | <b>P0[5]</b> — General purpose digital input/output pin.                                                                                                                                   |
|                                       |                    | I/O  | <b>I2SRX_WS</b> — Receive Word Select. It is driven by the master and received by the slave. Corresponds to the signal WS in the I <sup>2</sup> S-bus specification.                       |
|                                       |                    | O    | <b>TD2</b> — CAN2 transmitter output.                                                                                                                                                      |
|                                       |                    | I    | <b>CAP2[1]</b> — Capture input for Timer 2, channel 1.                                                                                                                                     |
| P0[6]/<br>I2SRX_SDA/<br>SSEL1/MAT2[0] | D11 <sup>[1]</sup> | I/O  | <b>P0[6]</b> — General purpose digital input/output pin.                                                                                                                                   |
|                                       |                    | I/O  | <b>I2SRX_SDA</b> — Receive data. It is driven by the transmitter and read by the receiver. Corresponds to the signal SD in the I <sup>2</sup> S-bus specification.                         |
|                                       |                    | I/O  | <b>SSEL1</b> — Slave Select for SSP1.                                                                                                                                                      |
|                                       |                    | O    | <b>MAT2[0]</b> — Match output for Timer 2, channel 0.                                                                                                                                      |
| P0[7]/<br>I2STX_CLK/<br>SCK1/MAT2[1]  | B12 <sup>[1]</sup> | I/O  | <b>P0[7]</b> — General purpose digital input/output pin.                                                                                                                                   |
|                                       |                    | I/O  | <b>I2STX_CLK</b> — Transmit Clock. It is driven by the master and received by the slave. Corresponds to the signal SCK in the I <sup>2</sup> S-bus specification.                          |
|                                       |                    | I/O  | <b>SCK1</b> — Serial Clock for SSP1.                                                                                                                                                       |
|                                       |                    | O    | <b>MAT2[1]</b> — Match output for Timer 2, channel 1.                                                                                                                                      |
| P0[8]/<br>I2STX_WS/<br>MISO1/MAT2[2]  | C12 <sup>[1]</sup> | I/O  | <b>P0[8]</b> — General purpose digital input/output pin.                                                                                                                                   |
|                                       |                    | I/O  | <b>I2STX_WS</b> — Transmit Word Select. It is driven by the master and received by the slave. Corresponds to the signal WS in the I <sup>2</sup> S-bus specification.                      |
|                                       |                    | I/O  | <b>MISO1</b> — Master In Slave Out for SSP1.                                                                                                                                               |
|                                       |                    | O    | <b>MAT2[2]</b> — Match output for Timer 2, channel 2.                                                                                                                                      |



Table 4. Pin description ...continued

| Symbol                                           | Ball               | Type | Description                                                                                                                                                                                         |
|--------------------------------------------------|--------------------|------|-----------------------------------------------------------------------------------------------------------------------------------------------------------------------------------------------------|
| P0[9]/<br>I2STX_SDA/<br>MOSI1/MAT2[3]            | A13 <sup>[1]</sup> | I/O  | <b>P0[9]</b> — General purpose digital input/output pin.                                                                                                                                            |
|                                                  |                    | I/O  | <b>I2STX_SDA</b> — Transmit data. It is driven by the transmitter and read by the receiver. Corresponds to the signal SD in the <i>I<sup>2</sup>S-bus specification</i> .                           |
|                                                  |                    | I/O  | <b>MOSI1</b> — Master Out Slave In for SSP1.                                                                                                                                                        |
|                                                  |                    | O    | <b>MAT2[3]</b> — Match output for Timer 2, channel 3.                                                                                                                                               |
| P0[10]/TXD2/<br>SDA2/MAT3[0]                     | L10 <sup>[1]</sup> | I/O  | <b>P0[10]</b> — General purpose digital input/output pin.                                                                                                                                           |
|                                                  |                    | O    | <b>TXD2</b> — Transmitter output for UART2.                                                                                                                                                         |
|                                                  |                    | I/O  | <b>SDA2</b> — I <sup>2</sup> C2 data input/output (this is not an open-drain pin).                                                                                                                  |
|                                                  |                    | O    | <b>MAT3[0]</b> — Match output for Timer 3, channel 0.                                                                                                                                               |
| P0[11]/RXD2/<br>SCL2/MAT3[1]                     | P12 <sup>[1]</sup> | I/O  | <b>P0[11]</b> — General purpose digital input/output pin.                                                                                                                                           |
|                                                  |                    | I    | <b>RXD2</b> — Receiver input for UART2.                                                                                                                                                             |
|                                                  |                    | I/O  | <b>SCL2</b> — I <sup>2</sup> C2 clock input/output (this is not an open-drain pin).                                                                                                                 |
|                                                  |                    | O    | <b>MAT3[1]</b> — Match output for Timer 3, channel 1.                                                                                                                                               |
| P0[12]/<br>USB_PPWR2/<br>MISO1/AD0[6]            | J4 <sup>[2]</sup>  | I/O  | <b>P0[12]</b> — General purpose digital input/output pin.                                                                                                                                           |
|                                                  |                    | O    | <b>USB_PPWR2</b> — Port Power enable signal for USB port 2.                                                                                                                                         |
|                                                  |                    | I/O  | <b>MISO1</b> — Master In Slave Out for SSP1.                                                                                                                                                        |
|                                                  |                    | I    | <b>AD0[6]</b> — A/D converter 0, input 6.                                                                                                                                                           |
| P0[13]/<br>USB_UP_LED2/<br>MOSI1/AD0[7]          | J5 <sup>[2]</sup>  | I/O  | <b>P0[13]</b> — General purpose digital input/output pin.                                                                                                                                           |
|                                                  |                    | O    | <b>USB_UP_LED2</b> — USB port 2 GoodLink LED indicator. It is LOW when device is configured (non-control endpoints enabled). It is HIGH when the device is not configured or during global suspend. |
|                                                  |                    | I/O  | <b>MOSI1</b> — Master Out Slave In for SSP1.                                                                                                                                                        |
|                                                  |                    | I    | <b>AD0[7]</b> — A/D converter 0, input 7.                                                                                                                                                           |
| P0[14]/<br>USB_HSTEN2/<br>USB_CONNECT2/<br>SSEL1 | M5 <sup>[1]</sup>  | I/O  | <b>P0[14]</b> — General purpose digital input/output pin.                                                                                                                                           |
|                                                  |                    | O    | <b>USB_HSTEN2</b> — Host Enabled status for USB port 2.                                                                                                                                             |
|                                                  |                    | O    | <b>USB_CONNECT2</b> — SoftConnect control for USB port 2. Signal used to switch an external 1.5 kΩ resistor under software control. Used with the SoftConnect USB feature.                          |
|                                                  |                    | I/O  | <b>SSEL1</b> — Slave Select for SSP1.                                                                                                                                                               |
| P0[15]/TXD1/<br>SCK0/SCK                         | H13 <sup>[1]</sup> | I/O  | <b>P0[15]</b> — General purpose digital input/output pin.                                                                                                                                           |
|                                                  |                    | O    | <b>TXD1</b> — Transmitter output for UART1.                                                                                                                                                         |
|                                                  |                    | I/O  | <b>SCK0</b> — Serial clock for SSP0.                                                                                                                                                                |
|                                                  |                    | I/O  | <b>SCK</b> — Serial clock for SPI.                                                                                                                                                                  |
| P0[16]/RXD1/<br>SSEL0/SSEL                       | H14 <sup>[1]</sup> | I/O  | <b>P0[16]</b> — General purpose digital input/output pin.                                                                                                                                           |
|                                                  |                    | I    | <b>RXD1</b> — Receiver input for UART1.                                                                                                                                                             |
|                                                  |                    | I/O  | <b>SSEL0</b> — Slave Select for SSP0.                                                                                                                                                               |
|                                                  |                    | I/O  | <b>SSEL</b> — Slave Select for SPI.                                                                                                                                                                 |
| P0[17]/CTS1/<br>MISO0/MISO                       | J12 <sup>[1]</sup> | I/O  | <b>P0[17]</b> — General purpose digital input/output pin.                                                                                                                                           |
|                                                  |                    | I    | <b>CTS1</b> — Clear to Send input for UART1.                                                                                                                                                        |
|                                                  |                    | I/O  | <b>MISO0</b> — Master In Slave Out for SSP0.                                                                                                                                                        |
|                                                  |                    | I/O  | <b>MISO</b> — Master In Slave Out for SPI.                                                                                                                                                          |

Table 4. Pin description ...continued

| Symbol                                  | Ball                 | Type | Description                                                                                                                                                          |
|-----------------------------------------|----------------------|------|----------------------------------------------------------------------------------------------------------------------------------------------------------------------|
| P0[18]/DCD1/<br>MOSI0/MOSI              | J13 <sup>[1]</sup>   | I/O  | <b>P0[18]</b> — General purpose digital input/output pin.                                                                                                            |
|                                         |                      | I    | <b>DCD1</b> — Data Carrier Detect input for UART1.                                                                                                                   |
|                                         |                      | I/O  | <b>MOSI0</b> — Master Out Slave In for SSP0.                                                                                                                         |
|                                         |                      | I/O  | <b>MOSI</b> — Master Out Slave In for SPI.                                                                                                                           |
| P0[19]/DSR1/<br>MCICLK/SDA1             | J10 <sup>[1]</sup>   | I/O  | <b>P0[19]</b> — General purpose digital input/output pin.                                                                                                            |
|                                         |                      | I    | <b>DSR1</b> — Data Set Ready input for UART1.                                                                                                                        |
|                                         |                      | O    | <b>MCICLK</b> — Clock output line for SD/MMC interface.                                                                                                              |
|                                         |                      | I/O  | <b>SDA1</b> — I <sup>2</sup> C1 data input/output (this is not an open-drain pin).                                                                                   |
| P0[20]/DTR1/<br>MCICMD/SCL1             | K14 <sup>[1]</sup>   | I/O  | <b>P0[20]</b> — General purpose digital input/output pin.                                                                                                            |
|                                         |                      | O    | <b>DTR1</b> — Data Terminal Ready output for UART1.                                                                                                                  |
|                                         |                      | I/O  | <b>MCICMD</b> — Command line for SD/MMC interface.                                                                                                                   |
|                                         |                      | I/O  | <b>SCL1</b> — I <sup>2</sup> C1 clock input/output (this is not an open-drain pin).                                                                                  |
| P0[21]/R11/<br>MCIPWR/RD1               | K11 <sup>[1]</sup>   | I/O  | <b>P0[21]</b> — General purpose digital input/output pin.                                                                                                            |
|                                         |                      | I    | <b>R11</b> — Ring Indicator input for UART1.                                                                                                                         |
|                                         |                      | O    | <b>MCIPWR</b> — Power Supply Enable for external SD/MMC power supply.                                                                                                |
|                                         |                      | I    | <b>RD1</b> — CAN1 receiver input.                                                                                                                                    |
| P0[22]/RTS1/<br>MCIDAT0/TD1             | L14 <sup>[1]</sup>   | I/O  | <b>P0[22]</b> — General purpose digital input/output pin.                                                                                                            |
|                                         |                      | O    | <b>RTS1</b> — Request to Send output for UART1.                                                                                                                      |
|                                         |                      | I/O  | <b>MCIDAT0</b> — Data line 0 for SD/MMC interface.                                                                                                                   |
|                                         |                      | O    | <b>TD1</b> — CAN1 transmitter output.                                                                                                                                |
| P0[23]/AD0[0]/<br>I2SRX_CLK/<br>CAP3[0] | F5 <sup>[2]</sup>    | I/O  | <b>P0[23]</b> — General purpose digital input/output pin.                                                                                                            |
|                                         |                      | I    | <b>AD0[0]</b> — A/D converter 0, input 0.                                                                                                                            |
|                                         |                      | I/O  | <b>I2SRX_CLK</b> — Receive Clock. It is driven by the master and received by the slave. Corresponds to the signal SCK in the I <sup>2</sup> S-bus specification.     |
|                                         |                      | I    | <b>CAP3[0]</b> — Capture input for Timer 3, channel 0.                                                                                                               |
| P0[24]/AD0[1]/<br>I2SRX_WS/<br>CAP3[1]  | E1 <sup>[2]</sup>    | I/O  | <b>P0[24]</b> — General purpose digital input/output pin.                                                                                                            |
|                                         |                      | I    | <b>AD0[1]</b> — A/D converter 0, input 1.                                                                                                                            |
|                                         |                      | I/O  | <b>I2SRX_WS</b> — Receive Word Select. It is driven by the master and received by the slave. Corresponds to the signal WS in the I <sup>2</sup> S-bus specification. |
|                                         |                      | I    | <b>CAP3[1]</b> — Capture input for Timer 3, channel 1.                                                                                                               |
| P0[25]/AD0[2]/<br>I2SRX_SDA/<br>TXD3    | E4 <sup>[2]</sup>    | I/O  | <b>P0[25]</b> — General purpose digital input/output pin.                                                                                                            |
|                                         |                      | I    | <b>AD0[2]</b> — A/D converter 0, input 2.                                                                                                                            |
|                                         |                      | I/O  | <b>I2SRX_SDA</b> — Receive data. It is driven by the transmitter and read by the receiver. Corresponds to the signal SD in the I <sup>2</sup> S-bus specification.   |
|                                         |                      | O    | <b>TXD3</b> — Transmitter output for UART3.                                                                                                                          |
| P0[26]/AD0[3]/<br>AOUT/RXD3             | D1 <sup>[2][3]</sup> | I/O  | <b>P0[26]</b> — General purpose digital input/output pin.                                                                                                            |
|                                         |                      | I    | <b>AD0[3]</b> — A/D converter 0, input 3.                                                                                                                            |
|                                         |                      | O    | <b>AOUT</b> — D/A converter output.                                                                                                                                  |
|                                         |                      | I    | <b>RXD3</b> — Receiver input for UART3.                                                                                                                              |
| P0[27]/SDA0                             | L3 <sup>[4]</sup>    | I/O  | <b>P0[27]</b> — General purpose digital input/output pin. Output is open-drain.                                                                                      |
|                                         |                      | I/O  | <b>SDA0</b> — I <sup>2</sup> C0 data input/output. Open-drain output (for I <sup>2</sup> C-bus compliance).                                                          |

Table 4. Pin description ...continued

| Symbol                                    | Ball               | Type | Description                                                                                                                                                                                |
|-------------------------------------------|--------------------|------|--------------------------------------------------------------------------------------------------------------------------------------------------------------------------------------------|
| P0[28]/SCL0                               | M1 <sup>[4]</sup>  | I/O  | <b>P0[28]</b> — General purpose digital input/output pin. Output is open-drain.                                                                                                            |
|                                           |                    | I/O  | <b>SCL0</b> — I <sup>2</sup> C0 clock input/output. Open-drain output (for I <sup>2</sup> C-bus compliance).                                                                               |
| P0[29]/USB_D+1                            | K5 <sup>[5]</sup>  | I/O  | <b>P0[29]</b> — General purpose digital input/output pin.                                                                                                                                  |
|                                           |                    | I/O  | <b>USB_D+1</b> — USB port 1 bidirectional D+ line.                                                                                                                                         |
| P0[30]/USB_D-1                            | N4 <sup>[5]</sup>  | I/O  | <b>P0[30]</b> — General purpose digital input/output pin.                                                                                                                                  |
|                                           |                    | I/O  | <b>USB_D-1</b> — USB port 1 bidirectional D- line.                                                                                                                                         |
| P0[31]/USB_D+2                            | N1 <sup>[5]</sup>  | I/O  | <b>P0[31]</b> — General purpose digital input/output pin.                                                                                                                                  |
|                                           |                    | I/O  | <b>USB_D+2</b> — USB port 2 bidirectional D+ line.                                                                                                                                         |
| P1[0] to P1[31]                           |                    | I/O  | <b>Port 1:</b> Port 1 is a 32 bit I/O port with individual direction controls for each bit. The operation of port 1 pins depends upon the pin function selected via the Pin Connect block. |
| P1[0]/ENET_TXD0                           | B5 <sup>[1]</sup>  | I/O  | <b>P1[0]</b> — General purpose digital input/output pin.                                                                                                                                   |
|                                           |                    | O    | <b>ENET_TXD0</b> — Ethernet transmit data 0 (RMII/MII interface).                                                                                                                          |
| P1[1]/ENET_TXD1                           | A5 <sup>[1]</sup>  | I/O  | <b>P1[1]</b> — General purpose digital input/output pin.                                                                                                                                   |
|                                           |                    | O    | <b>ENET_TXD1</b> — Ethernet transmit data 1 (RMII/MII interface).                                                                                                                          |
| P1[2]/ENET_TXD2/<br>MCICLK/<br>PWM0[1]    | B7 <sup>[1]</sup>  | I/O  | <b>P1[2]</b> — General purpose digital input/output pin.                                                                                                                                   |
|                                           |                    | O    | <b>ENET_TXD2</b> — Ethernet transmit data 2 (MII interface).                                                                                                                               |
|                                           |                    | O    | <b>MCICLK</b> — Clock output line for SD/MMC interface.                                                                                                                                    |
|                                           |                    | O    | <b>PWM0[1]</b> — Pulse Width Modulator 0, output 1.                                                                                                                                        |
| P1[3]/ENET_TXD3/<br>MCICMD/<br>PWM0[2]    | A9 <sup>[1]</sup>  | I/O  | <b>P1[3]</b> — General purpose digital input/output pin.                                                                                                                                   |
|                                           |                    | O    | <b>ENET_TXD3</b> — Ethernet transmit data 3 (MII interface).                                                                                                                               |
|                                           |                    | I/O  | <b>MCICMD</b> — Command line for SD/MMC interface.                                                                                                                                         |
|                                           |                    | O    | <b>PWM0[2]</b> — Pulse Width Modulator 0, output 2.                                                                                                                                        |
| P1[4]/ENET_TX_EN                          | C6 <sup>[1]</sup>  | I/O  | <b>P1[4]</b> — General purpose digital input/output pin.                                                                                                                                   |
|                                           |                    | O    | <b>ENET_TX_EN</b> — Ethernet transmit data enable (RMII/MII interface).                                                                                                                    |
| P1[5]/ENET_TX_ER/<br>MCIPWR/<br>PWM0[3]   | B13 <sup>[1]</sup> | I/O  | <b>P1[5]</b> — General purpose digital input/output pin.                                                                                                                                   |
|                                           |                    | O    | <b>ENET_TX_ER</b> — Ethernet Transmit Error (MII interface).                                                                                                                               |
|                                           |                    | O    | <b>MCIPWR</b> — Power Supply Enable for external SD/MMC power supply.                                                                                                                      |
|                                           |                    | O    | <b>PWM0[3]</b> — Pulse Width Modulator 0, output 3.                                                                                                                                        |
| P1[6]/ENET_TX_CLK/<br>MCIDAT0/<br>PWM0[4] | B10 <sup>[1]</sup> | I/O  | <b>P1[6]</b> — General purpose digital input/output pin.                                                                                                                                   |
|                                           |                    | I    | <b>ENET_TX_CLK</b> — Ethernet Transmit Clock (MII interface).                                                                                                                              |
|                                           |                    | I/O  | <b>MCIDAT0</b> — Data line 0 for SD/MMC interface.                                                                                                                                         |
|                                           |                    | O    | <b>PWM0[4]</b> — Pulse Width Modulator 0, output 4.                                                                                                                                        |
| P1[7]/ENET_COL/<br>MCIDAT1/<br>PWM0[5]    | C13 <sup>[1]</sup> | I/O  | <b>P1[7]</b> — General purpose digital input/output pin.                                                                                                                                   |
|                                           |                    | I    | <b>ENET_COL</b> — Ethernet Collision detect (MII interface).                                                                                                                               |
|                                           |                    | I/O  | <b>MCIDAT1</b> — Data line 1 for SD/MMC interface.                                                                                                                                         |
|                                           |                    | O    | <b>PWM0[5]</b> — Pulse Width Modulator 0, output 5.                                                                                                                                        |
| P1[8]/ENET_CRS_DV/<br>ENET_CRS            | B6 <sup>[1]</sup>  | I/O  | <b>P1[8]</b> — General purpose digital input/output pin.                                                                                                                                   |
|                                           |                    | I    | <b>ENET_CRS_DV/ENET_CRS</b> — Ethernet Carrier Sense/Data Valid (RMII interface)/ Ethernet Carrier Sense (MII interface).                                                                  |
| P1[9]/ENET_RXD0                           | D7 <sup>[1]</sup>  | I/O  | <b>P1[9]</b> — General purpose digital input/output pin.                                                                                                                                   |
|                                           |                    | I    | <b>ENET_RXD0</b> — Ethernet receive data 0 (RMII/MII interface).                                                                                                                           |

Table 4. Pin description ...continued

| Symbol                                         | Ball               | Type | Description                                                                                                                                                                                         |
|------------------------------------------------|--------------------|------|-----------------------------------------------------------------------------------------------------------------------------------------------------------------------------------------------------|
| P1[10]/<br>ENET_RXD1                           | A7 <sup>[1]</sup>  | I/O  | <b>P1[10]</b> — General purpose digital input/output pin.                                                                                                                                           |
|                                                |                    | I    | <b>ENET_RXD1</b> — Ethernet receive data 1 (RMII/MII interface).                                                                                                                                    |
| P1[11]/<br>ENET_RXD2/<br>MCIDAT2/<br>PWM0[6]   | A12 <sup>[1]</sup> | I/O  | <b>P1[11]</b> — General purpose digital input/output pin.                                                                                                                                           |
|                                                |                    | I    | <b>ENET_RXD2</b> — Ethernet Receive Data 2 (MII interface).                                                                                                                                         |
|                                                |                    | I/O  | <b>MCIDAT2</b> — Data line 2 for SD/MMC interface.                                                                                                                                                  |
|                                                |                    | O    | <b>PWM0[6]</b> — Pulse Width Modulator 0, output 6.                                                                                                                                                 |
| P1[12]/<br>ENET_RXD3/<br>MCIDAT3/<br>PCAP0[0]  | A14 <sup>[1]</sup> | I/O  | <b>P1[12]</b> — General purpose digital input/output pin.                                                                                                                                           |
|                                                |                    | I    | <b>ENET_RXD3</b> — Ethernet Receive Data (MII interface).                                                                                                                                           |
|                                                |                    | I/O  | <b>MCIDAT3</b> — Data line 3 for SD/MMC interface.                                                                                                                                                  |
|                                                |                    | I    | <b>PCAP0[0]</b> — Capture input for PWM0, channel 0.                                                                                                                                                |
| P1[13]/<br>ENET_RX_DV                          | D14 <sup>[1]</sup> | I/O  | <b>P1[13]</b> — General purpose digital input/output pin.                                                                                                                                           |
|                                                |                    | I    | <b>ENET_RX_DV</b> — Ethernet Receive Data Valid (MII interface).                                                                                                                                    |
| P1[14]/<br>ENET_RX_ER                          | D8 <sup>[1]</sup>  | I/O  | <b>P1[14]</b> — General purpose digital input/output pin.                                                                                                                                           |
|                                                |                    | I    | <b>ENET_RX_ER</b> — Ethernet receive error (RMII/MII interface).                                                                                                                                    |
| P1[15]/<br>ENET_REF_CLK/<br>ENET_RX_CLK        | A8 <sup>[1]</sup>  | I/O  | <b>P1[15]</b> — General purpose digital input/output pin.                                                                                                                                           |
|                                                |                    | I    | <b>ENET_REF_CLK/ENET_RX_CLK</b> — Ethernet Reference Clock (RMII interface)/<br>Ethernet Receive Clock (MII interface).                                                                             |
| P1[16]/<br>ENET_MDC                            | B8 <sup>[1]</sup>  | I/O  | <b>P1[16]</b> — General purpose digital input/output pin.                                                                                                                                           |
|                                                |                    | O    | <b>ENET_MDC</b> — Ethernet MIIM clock.                                                                                                                                                              |
| P1[17]/<br>ENET_MDIO                           | C9 <sup>[1]</sup>  | I/O  | <b>P1[17]</b> — General purpose digital input/output pin.                                                                                                                                           |
|                                                |                    | I/O  | <b>ENET_MDIO</b> — Ethernet MI data input and output.                                                                                                                                               |
| P1[18]/<br>USB_UP_LED1/<br>PWM1[1]/<br>CAP1[0] | L5 <sup>[1]</sup>  | I/O  | <b>P1[18]</b> — General purpose digital input/output pin.                                                                                                                                           |
|                                                |                    | O    | <b>USB_UP_LED1</b> — USB port 1 GoodLink LED indicator. It is LOW when device is configured (non-control endpoints enabled). It is HIGH when the device is not configured or during global suspend. |
|                                                |                    | O    | <b>PWM1[1]</b> — Pulse Width Modulator 1, channel 1 output.                                                                                                                                         |
|                                                |                    | I    | <b>CAP1[0]</b> — Capture input for Timer 1, channel 0.                                                                                                                                              |
| P1[19]/<br>USB_TX_E1/<br>USB_PPWR1/<br>CAP1[1] | P5 <sup>[1]</sup>  | I/O  | <b>P1[19]</b> — General purpose digital input/output pin.                                                                                                                                           |
|                                                |                    | O    | <b>USB_TX_E1</b> — Transmit Enable signal for USB port 1 (OTG transceiver).                                                                                                                         |
|                                                |                    | O    | <b>USB_PPWR1</b> — Port Power enable signal for USB port 1.                                                                                                                                         |
|                                                |                    | I    | <b>CAP1[1]</b> — Capture input for Timer 1, channel 1.                                                                                                                                              |
| P1[20]/<br>USB_TX_DP1/<br>PWM1[2]/SCK0         | K6 <sup>[1]</sup>  | I/O  | <b>P1[20]</b> — General purpose digital input/output pin.                                                                                                                                           |
|                                                |                    | O    | <b>USB_TX_DP1</b> — D+ transmit data for USB port 1 (OTG transceiver).                                                                                                                              |
|                                                |                    | O    | <b>PWM1[2]</b> — Pulse Width Modulator 1, channel 2 output.                                                                                                                                         |
|                                                |                    | I/O  | <b>SCK0</b> — Serial clock for SSP0.                                                                                                                                                                |
| P1[21]/<br>USB_TX_DM1/<br>PWM1[3]/SSEL0        | N6 <sup>[1]</sup>  | I/O  | <b>P1[21]</b> — General purpose digital input/output pin.                                                                                                                                           |
|                                                |                    | O    | <b>USB_TX_DM1</b> — D– transmit data for USB port 1 (OTG transceiver).                                                                                                                              |
|                                                |                    | O    | <b>PWM1[3]</b> — Pulse Width Modulator 1, channel 3 output.                                                                                                                                         |
|                                                |                    | I/O  | <b>SSEL0</b> — Slave Select for SSP0.                                                                                                                                                               |

Table 4. Pin description ...continued

| Symbol                                            | Ball               | Type | Description                                                                                                                       |
|---------------------------------------------------|--------------------|------|-----------------------------------------------------------------------------------------------------------------------------------|
| P1[22]/<br>USB_RCV1/<br>USB_PWRD1/<br>MAT1[0]     | M6 <sup>[1]</sup>  | I/O  | <b>P1[22]</b> — General purpose digital input/output pin.                                                                         |
|                                                   |                    | I    | <b>USB_RCV1</b> — Differential receive data for USB port 1 (OTG transceiver).                                                     |
|                                                   |                    | I    | <b>USB_PWRD1</b> — Power Status for USB port 1 (host power switch).                                                               |
|                                                   |                    | O    | <b>MAT1[0]</b> — Match output for Timer 1, channel 0.                                                                             |
| P1[23]/<br>USB_RX_DP1/<br>PWM1[4]/MISO0           | N7 <sup>[1]</sup>  | I/O  | <b>P1[23]</b> — General purpose digital input/output pin.                                                                         |
|                                                   |                    | I    | <b>USB_RX_DP1</b> — D+ receive data for USB port 1 (OTG transceiver).                                                             |
|                                                   |                    | O    | <b>PWM1[4]</b> — Pulse Width Modulator 1, channel 4 output.                                                                       |
|                                                   |                    | I/O  | <b>MISO0</b> — Master In Slave Out for SSP0.                                                                                      |
| P1[24]/<br>USB_RX_DM1/<br>PWM1[5]/MOSI0           | P7 <sup>[1]</sup>  | I/O  | <b>P1[24]</b> — General purpose digital input/output pin.                                                                         |
|                                                   |                    | I    | <b>USB_RX_DM1</b> — D– receive data for USB port 1 (OTG transceiver).                                                             |
|                                                   |                    | O    | <b>PWM1[5]</b> — Pulse Width Modulator 1, channel 5 output.                                                                       |
|                                                   |                    | I/O  | <b>MOSI0</b> — Master Out Slave in for SSP0.                                                                                      |
| P1[25]/<br>USB_LS1/<br>USB_HSTEN1/<br>MAT1[1]     | L7 <sup>[1]</sup>  | I/O  | <b>P1[25]</b> — General purpose digital input/output pin.                                                                         |
|                                                   |                    | O    | <b>USB_LS1</b> — Low-speed status for USB port 1 (OTG transceiver).                                                               |
|                                                   |                    | O    | <b>USB_HSTEN1</b> — Host Enabled status for USB port 1.                                                                           |
|                                                   |                    | O    | <b>MAT1[1]</b> — Match output for Timer 1, channel 1.                                                                             |
| P1[26]/<br>USB_SSPND1/<br>PWM1[6]/<br>CAP0[0]     | P8 <sup>[1]</sup>  | I/O  | <b>P1[26]</b> — General purpose digital input/output pin.                                                                         |
|                                                   |                    | O    | <b>USB_SSPND1</b> — USB port 1 Bus Suspend status (OTG transceiver).                                                              |
|                                                   |                    | O    | <b>PWM1[6]</b> — Pulse Width Modulator 1, channel 6 output.                                                                       |
|                                                   |                    | I    | <b>CAP0[0]</b> — Capture input for Timer 0, channel 0.                                                                            |
| P1[27]/<br>USB_INT1/<br>USB_OVRCR1/<br>CAP0[1]    | M9 <sup>[1]</sup>  | I/O  | <b>P1[27]</b> — General purpose digital input/output pin.                                                                         |
|                                                   |                    | I    | <b>USB_INT1</b> — USB port 1 OTG transceiver interrupt.                                                                           |
|                                                   |                    | I    | <b>USB_OVRCR1</b> — USB port 1 Over-Current status.                                                                               |
|                                                   |                    | I    | <b>CAP0[1]</b> — Capture input for Timer 0, channel 1.                                                                            |
| P1[28]/<br>USB_SCL1/<br>PCAP1[0]/<br>MAT0[0]      | P10 <sup>[1]</sup> | I/O  | <b>P1[28]</b> — General purpose digital input/output pin.                                                                         |
|                                                   |                    | I/O  | <b>USB_SCL1</b> — USB port 1 I <sup>2</sup> C serial clock (OTG transceiver).                                                     |
|                                                   |                    | I    | <b>PCAP1[0]</b> — Capture input for PWM1, channel 0.                                                                              |
|                                                   |                    | O    | <b>MAT0[0]</b> — Match output for Timer 0, channel 0.                                                                             |
| P1[29]/<br>USB_SDA1/<br>PCAP1[1]/<br>MAT0[1]      | N10 <sup>[1]</sup> | I/O  | <b>P1[29]</b> — General purpose digital input/output pin.                                                                         |
|                                                   |                    | I/O  | <b>USB_SDA1</b> — USB port 1 I <sup>2</sup> C serial data (OTG transceiver).                                                      |
|                                                   |                    | I    | <b>PCAP1[1]</b> — Capture input for PWM1, channel 1.                                                                              |
|                                                   |                    | O    | <b>MAT0[1]</b> — Match output for Timer 0, channel 0.                                                                             |
| P1[30]/<br>USB_PWRD2/<br>V <sub>BUS</sub> /AD0[4] | K3 <sup>[2]</sup>  | I/O  | <b>P1[30]</b> — General purpose digital input/output pin.                                                                         |
|                                                   |                    | I    | <b>USB_PWRD2</b> — Power Status for USB port 2.                                                                                   |
|                                                   |                    | I    | <b>V<sub>BUS</sub></b> — Monitors the presence of USB bus power.<br><b>Note:</b> This signal must be HIGH for USB reset to occur. |
|                                                   |                    | I    | <b>AD0[4]</b> — A/D converter 0, input 4.                                                                                         |
| P1[31]/<br>USB_OVRCR2/<br>SCK1/AD0[5]             | K2 <sup>[2]</sup>  | I/O  | <b>P1[31]</b> — General purpose digital input/output pin.                                                                         |
|                                                   |                    | I    | <b>USB_OVRCR2</b> — Over-Current status for USB port 2.                                                                           |
|                                                   |                    | I/O  | <b>SCK1</b> — Serial Clock for SSP1.                                                                                              |
|                                                   |                    | I    | <b>AD0[5]</b> — A/D converter 0, input 5.                                                                                         |

Table 4. Pin description ...continued

| Symbol                               | Ball               | Type | Description                                                                                                                                                                                                                                                        |
|--------------------------------------|--------------------|------|--------------------------------------------------------------------------------------------------------------------------------------------------------------------------------------------------------------------------------------------------------------------|
| P2[0] to P2[31]                      |                    | I/O  | <b>Port 2:</b> Port 2 is a 32-bit I/O port with individual direction controls for each bit. The operation of port 2 pins depends upon the pin function selected via the Pin Connect block.<br>Pins P2[14:15], P2[22:23], P[26:27] and P2[30:31] are not available. |
| P2[0]/PWM1[1]/<br>TXD1/<br>TRACECLK  | D12 <sup>[1]</sup> | I/O  | <b>P2[0]</b> — General purpose digital input/output pin.                                                                                                                                                                                                           |
|                                      |                    | O    | <b>PWM1[1]</b> — Pulse Width Modulator 1, channel 1 output.                                                                                                                                                                                                        |
|                                      |                    | O    | <b>TXD1</b> — Transmitter output for UART1.                                                                                                                                                                                                                        |
|                                      |                    | O    | <b>TRACECLK</b> — Trace Clock.                                                                                                                                                                                                                                     |
| P2[1]/PWM1[2]/<br>RXD1/<br>PIPESTAT0 | C14 <sup>[1]</sup> | I/O  | <b>P2[1]</b> — General purpose digital input/output pin.                                                                                                                                                                                                           |
|                                      |                    | O    | <b>PWM1[2]</b> — Pulse Width Modulator 1, channel 2 output.                                                                                                                                                                                                        |
|                                      |                    | I    | <b>RXD1</b> — Receiver input for UART1.                                                                                                                                                                                                                            |
|                                      |                    | O    | <b>PIPESTAT0</b> — Pipeline Status, bit 0.                                                                                                                                                                                                                         |
| P2[2]/PWM1[3]/<br>CTS1/<br>PIPESTAT1 | E11 <sup>[1]</sup> | I/O  | <b>P2[2]</b> — General purpose digital input/output pin.                                                                                                                                                                                                           |
|                                      |                    | O    | <b>PWM1[3]</b> — Pulse Width Modulator 1, channel 3 output.                                                                                                                                                                                                        |
|                                      |                    | I    | <b>CTS1</b> — Clear to Send input for UART1.                                                                                                                                                                                                                       |
|                                      |                    | O    | <b>PIPESTAT1</b> — Pipeline Status, bit 1.                                                                                                                                                                                                                         |
| P2[3]/PWM1[4]/<br>DCD1/<br>PIPESTAT2 | E13 <sup>[1]</sup> | I/O  | <b>P2[3]</b> — General purpose digital input/output pin.                                                                                                                                                                                                           |
|                                      |                    | O    | <b>PWM1[4]</b> — Pulse Width Modulator 1, channel 4 output.                                                                                                                                                                                                        |
|                                      |                    | I    | <b>DCD1</b> — Data Carrier Detect input for UART1.                                                                                                                                                                                                                 |
|                                      |                    | O    | <b>PIPESTAT2</b> — Pipeline Status, bit 2.                                                                                                                                                                                                                         |
| P2[4]/PWM1[5]/<br>DSR1/<br>TRACESYNC | E14 <sup>[1]</sup> | I/O  | <b>P2[4]</b> — General purpose digital input/output pin.                                                                                                                                                                                                           |
|                                      |                    | O    | <b>PWM1[5]</b> — Pulse Width Modulator 1, channel 5 output.                                                                                                                                                                                                        |
|                                      |                    | I    | <b>DSR1</b> — Data Set Ready input for UART1.                                                                                                                                                                                                                      |
|                                      |                    | O    | <b>TRACESYNC</b> — Trace Synchronization.                                                                                                                                                                                                                          |
| P2[5]/PWM1[6]/<br>DTR1/<br>TRACEPKT0 | F12 <sup>[1]</sup> | I/O  | <b>P2[5]</b> — General purpose digital input/output pin.                                                                                                                                                                                                           |
|                                      |                    | O    | <b>PWM1[6]</b> — Pulse Width Modulator 1, channel 6 output.                                                                                                                                                                                                        |
|                                      |                    | O    | <b>DTR1</b> — Data Terminal Ready output for UART1.                                                                                                                                                                                                                |
|                                      |                    | O    | <b>TRACEPKT0</b> — Trace Packet, bit 0.                                                                                                                                                                                                                            |
| P2[6]/PCAP1[0]/RI1/<br>TRACEPKT1     | F13 <sup>[1]</sup> | I/O  | <b>P2[6]</b> — General purpose digital input/output pin.                                                                                                                                                                                                           |
|                                      |                    | I    | <b>PCAP1[0]</b> — Capture input for PWM1, channel 0.                                                                                                                                                                                                               |
|                                      |                    | I    | <b>RI1</b> — Ring Indicator input for UART1.                                                                                                                                                                                                                       |
|                                      |                    | O    | <b>TRACEPKT1</b> — Trace Packet, bit 1.                                                                                                                                                                                                                            |
| P2[7]/RD2/<br>RTS1/<br>TRACEPKT2     | G11 <sup>[1]</sup> | I/O  | <b>P2[7]</b> — General purpose digital input/output pin.                                                                                                                                                                                                           |
|                                      |                    | I    | <b>RD2</b> — CAN2 receiver input.                                                                                                                                                                                                                                  |
|                                      |                    | O    | <b>RTS1</b> — Request to Send output for UART1.                                                                                                                                                                                                                    |
|                                      |                    | O    | <b>TRACEPKT2</b> — Trace Packet, bit 2.                                                                                                                                                                                                                            |
| P2[8]/TD2/<br>TXD2/<br>TRACEPKT3     | G14 <sup>[1]</sup> | I/O  | <b>P2[8]</b> — General purpose digital input/output pin.                                                                                                                                                                                                           |
|                                      |                    | O    | <b>TD2</b> — CAN2 transmitter output.                                                                                                                                                                                                                              |
|                                      |                    | O    | <b>TXD2</b> — Transmitter output for UART2.                                                                                                                                                                                                                        |
|                                      |                    | O    | <b>TRACEPKT3</b> — Trace Packet, bit 3.                                                                                                                                                                                                                            |

Table 4. Pin description ...continued

| Symbol                                                       | Ball               | Type | Description                                                                                                                                                                                                |
|--------------------------------------------------------------|--------------------|------|------------------------------------------------------------------------------------------------------------------------------------------------------------------------------------------------------------|
| P2[9]/<br>USB_CONNECT1/<br>RXD2/<br>EXTIN0                   | H11 <sup>[1]</sup> | I/O  | <b>P2[9]</b> — General purpose digital input/output pin.                                                                                                                                                   |
|                                                              |                    | O    | <b>USB_CONNECT1</b> — USB1 SoftConnect control. Signal used to switch an external 1.5 kΩ resistor under the software control. Used with the SoftConnect USB feature.                                       |
|                                                              |                    | I    | <b>RXD2</b> — Receiver input for UART2.                                                                                                                                                                    |
|                                                              |                    | I    | <b>EXTIN0</b> — External Trigger Input.                                                                                                                                                                    |
| P2[10]/ $\overline{\text{EINT0}}$                            | M13 <sup>[6]</sup> | I/O  | <b>P2[10]</b> — General purpose digital input/output pin.<br><b>Note:</b> LOW on this pin while $\overline{\text{RESET}}$ is LOW forces on-chip bootloader to take over control of the part after a reset. |
|                                                              |                    | I    | $\overline{\text{EINT0}}$ — External interrupt 0 input.                                                                                                                                                    |
| P2[11]/ $\overline{\text{EINT1}}$ /<br>MCIDAT1/<br>I2STX_CLK | M12 <sup>[6]</sup> | I/O  | <b>P2[11]</b> — General purpose digital input/output pin.                                                                                                                                                  |
|                                                              |                    | I    | $\overline{\text{EINT1}}$ — External interrupt 1 input.                                                                                                                                                    |
|                                                              |                    | I/O  | <b>MCIDAT1</b> — Data line 1 for SD/MMC interface.                                                                                                                                                         |
|                                                              |                    | I/O  | <b>I2STX_CLK</b> — Transmit Clock. It is driven by the master and received by the slave. Corresponds to the signal SCK in the <i>I<sup>2</sup>S-bus specification</i> .                                    |
| P2[12]/ $\overline{\text{EINT2}}$ /<br>MCIDAT2/<br>I2STX_WS  | N14 <sup>[6]</sup> | I/O  | <b>P2[12]</b> — General purpose digital input/output pin.                                                                                                                                                  |
|                                                              |                    | I    | $\overline{\text{EINT2}}$ — External interrupt 2 input.                                                                                                                                                    |
|                                                              |                    | I/O  | <b>MCIDAT2</b> — Data line 2 for SD/MMC interface.                                                                                                                                                         |
|                                                              |                    | I/O  | <b>I2STX_WS</b> — Transmit Word Select. It is driven by the master and received by the slave. Corresponds to the signal WS in the <i>I<sup>2</sup>S-bus specification</i> .                                |
| P2[13]/ $\overline{\text{EINT3}}$ /<br>MCIDAT3/<br>I2STX_SDA | M11 <sup>[6]</sup> | I/O  | <b>P2[13]</b> — General purpose digital input/output pin.                                                                                                                                                  |
|                                                              |                    | I    | $\overline{\text{EINT3}}$ — External interrupt 3 input.                                                                                                                                                    |
|                                                              |                    | I/O  | <b>MCIDAT3</b> — Data line 3 for SD/MMC interface.                                                                                                                                                         |
|                                                              |                    | I/O  | <b>I2STX_SDA</b> — Transmit data. It is driven by the transmitter and read by the receiver. Corresponds to the signal SD in the <i>I<sup>2</sup>S-bus specification</i> .                                  |
| P2[16]/ $\overline{\text{CAS}}$                              | P9 <sup>[1]</sup>  | I/O  | <b>P2[16]</b> — General purpose digital input/output pin.                                                                                                                                                  |
|                                                              |                    | O    | $\overline{\text{CAS}}$ — LOW active SDRAM Column Address Strobe.                                                                                                                                          |
| P2[17]/ $\overline{\text{RAS}}$                              | P11 <sup>[1]</sup> | I/O  | <b>P2[17]</b> — General purpose digital input/output pin.                                                                                                                                                  |
|                                                              |                    | O    | $\overline{\text{RAS}}$ — LOW active SDRAM Row Address Strobe.                                                                                                                                             |
| P2[18]/<br>CLKOUT0                                           | P3 <sup>[1]</sup>  | I/O  | <b>P2[18]</b> — General purpose digital input/output pin.                                                                                                                                                  |
|                                                              |                    | O    | <b>CLKOUT0</b> — SDRAM clock 0.                                                                                                                                                                            |
| P2[19]/<br>CLKOUT1                                           | N5 <sup>[1]</sup>  | I/O  | <b>P2[19]</b> — General purpose digital input/output pin.                                                                                                                                                  |
|                                                              |                    | O    | <b>CLKOUT1</b> — SDRAM clock 1.                                                                                                                                                                            |
| P2[20]/ $\overline{\text{DYCS0}}$                            | P6 <sup>[1]</sup>  | I/O  | <b>P2[20]</b> — General purpose digital input/output pin.                                                                                                                                                  |
|                                                              |                    | O    | $\overline{\text{DYCS0}}$ — SDRAM chip select 0.                                                                                                                                                           |
| P2[21]/ $\overline{\text{DYCS1}}$                            | N8 <sup>[1]</sup>  | I/O  | <b>P2[21]</b> — General purpose digital input/output pin.                                                                                                                                                  |
|                                                              |                    | O    | $\overline{\text{DYCS1}}$ — SDRAM chip select 1.                                                                                                                                                           |
| P2[24]/<br>CKEOUT0                                           | P1 <sup>[1]</sup>  | I/O  | <b>P2[24]</b> — General purpose digital input/output pin.                                                                                                                                                  |
|                                                              |                    | O    | <b>CKEOUT0</b> — SDRAM clock enable 0.                                                                                                                                                                     |
| P2[25]/<br>CKEOUT1                                           | P2 <sup>[1]</sup>  | I/O  | <b>P2[25]</b> — General purpose digital input/output pin.                                                                                                                                                  |
|                                                              |                    | O    | <b>CKEOUT1</b> — SDRAM clock enable 1.                                                                                                                                                                     |

Table 4. Pin description ...continued

| Symbol             | Ball              | Type | Description                                                                                                                                                                                                                                   |
|--------------------|-------------------|------|-----------------------------------------------------------------------------------------------------------------------------------------------------------------------------------------------------------------------------------------------|
| P2[28]/<br>DQMOUT0 | M2 <sup>[1]</sup> | I/O  | <b>P2[28]</b> — General purpose digital input/output pin.                                                                                                                                                                                     |
|                    |                   | O    | <b>DQMOUT0</b> — Data mask 0 used with SDRAM and static devices.                                                                                                                                                                              |
| P2[29]/<br>DQMOUT1 | L1 <sup>[1]</sup> | I/O  | <b>P2[29]</b> — General purpose digital input/output pin.                                                                                                                                                                                     |
|                    |                   | O    | <b>DQMOUT1</b> — Data mask 1 used with SDRAM and static devices.                                                                                                                                                                              |
| P3[0] to P3[31]    |                   | I/O  | <b>Port 3:</b> Port 3 is a 32-bit I/O port with individual direction controls for each bit. The operation of port 3 pins depends upon the pin function selected via the Pin Connect block.<br>Pins P3[16:22] and P3[27:31] are not available. |
| P3[0]/D0           | D6 <sup>[1]</sup> | I/O  | <b>P3[0]</b> — General purpose digital input/output pin.                                                                                                                                                                                      |
|                    |                   | I/O  | <b>D0</b> — External memory data line 0.                                                                                                                                                                                                      |
| P3[1]/D1           | E6 <sup>[1]</sup> | I/O  | <b>P3[1]</b> — General purpose digital input/output pin.                                                                                                                                                                                      |
|                    |                   | I/O  | <b>D1</b> — External memory data line 1.                                                                                                                                                                                                      |
| P3[2]/D2           | A2 <sup>[1]</sup> | I/O  | <b>P3[2]</b> — General purpose digital input/output pin.                                                                                                                                                                                      |
|                    |                   | I/O  | <b>D2</b> — External memory data line 2.                                                                                                                                                                                                      |
| P3[3]/D3           | G5 <sup>[1]</sup> | I/O  | <b>P3[3]</b> — General purpose digital input/output pin.                                                                                                                                                                                      |
|                    |                   | I/O  | <b>D3</b> — External memory data line 3.                                                                                                                                                                                                      |
| P3[4]/D4           | D3 <sup>[1]</sup> | I/O  | <b>P3[4]</b> — General purpose digital input/output pin.                                                                                                                                                                                      |
|                    |                   | I/O  | <b>D4</b> — External memory data line 4.                                                                                                                                                                                                      |
| P3[5]/D5           | E3 <sup>[1]</sup> | I/O  | <b>P3[5]</b> — General purpose digital input/output pin.                                                                                                                                                                                      |
|                    |                   | I/O  | <b>D5</b> — External memory data line 5.                                                                                                                                                                                                      |
| P3[6]/D6           | F4 <sup>[1]</sup> | I/O  | <b>P3[6]</b> — General purpose digital input/output pin.                                                                                                                                                                                      |
|                    |                   | I/O  | <b>D6</b> — External memory data line 6.                                                                                                                                                                                                      |
| P3[7]/D7           | G3 <sup>[1]</sup> | I/O  | <b>P3[7]</b> — General purpose digital input/output pin.                                                                                                                                                                                      |
|                    |                   | I/O  | <b>D7</b> — External memory data line 7.                                                                                                                                                                                                      |
| P3[8]/D8           | A6 <sup>[1]</sup> | I/O  | <b>P3[8]</b> — General purpose digital input/output pin.                                                                                                                                                                                      |
|                    |                   | I/O  | <b>D8</b> — External memory data line 8.                                                                                                                                                                                                      |
| P3[9]/D9           | A4 <sup>[1]</sup> | I/O  | <b>P3[9]</b> — General purpose digital input/output pin.                                                                                                                                                                                      |
|                    |                   | I/O  | <b>D9</b> — External memory data line 9.                                                                                                                                                                                                      |
| P3[10]/D10         | B3 <sup>[1]</sup> | I/O  | <b>P3[10]</b> — General purpose digital input/output pin.                                                                                                                                                                                     |
|                    |                   | I/O  | <b>D10</b> — External memory data line 10.                                                                                                                                                                                                    |
| P3[11]/D11         | B2 <sup>[1]</sup> | I/O  | <b>P3[11]</b> — General purpose digital input/output pin.                                                                                                                                                                                     |
|                    |                   | I/O  | <b>D11</b> — External memory data line 11.                                                                                                                                                                                                    |
| P3[12]/D12         | A1 <sup>[1]</sup> | I/O  | <b>P3[12]</b> — General purpose digital input/output pin.                                                                                                                                                                                     |
|                    |                   | I/O  | <b>D12</b> — External memory data line 12.                                                                                                                                                                                                    |
| P3[13]/D13         | C1 <sup>[1]</sup> | I/O  | <b>P3[13]</b> — General purpose digital input/output pin.                                                                                                                                                                                     |
|                    |                   | I/O  | <b>D13</b> — External memory data line 13.                                                                                                                                                                                                    |
| P3[14]/D14         | F1 <sup>[1]</sup> | I/O  | <b>P3[14]</b> — General purpose digital input/output pin.                                                                                                                                                                                     |
|                    |                   | I/O  | <b>D14</b> — External memory data line 14.                                                                                                                                                                                                    |
| P3[15]/D15         | G4 <sup>[1]</sup> | I/O  | <b>P3[15]</b> — General purpose digital input/output pin.                                                                                                                                                                                     |
|                    |                   | I/O  | <b>D15</b> — External memory data line 15.                                                                                                                                                                                                    |



Table 4. Pin description ...continued

| Symbol                  | Ball               | Type | Description                                                                                                                                                                                                                     |
|-------------------------|--------------------|------|---------------------------------------------------------------------------------------------------------------------------------------------------------------------------------------------------------------------------------|
| P3[23]/CAP0[0]/PCAP1[0] | M4 <sup>[1]</sup>  | I/O  | <b>P3[23]</b> — General purpose digital input/output pin.                                                                                                                                                                       |
|                         |                    | I    | <b>CAP0[0]</b> — Capture input for Timer 0, channel 0.                                                                                                                                                                          |
|                         |                    | I    | <b>PCAP1[0]</b> — Capture input for PWM1, channel 0.                                                                                                                                                                            |
| P3[24]/CAP0[1]/PWM1[1]  | N3 <sup>[1]</sup>  | I/O  | <b>P3[24]</b> — General purpose digital input/output pin.                                                                                                                                                                       |
|                         |                    | I    | <b>CAP0[1]</b> — Capture input for Timer 0, channel 1.                                                                                                                                                                          |
|                         |                    | O    | <b>PWM1[1]</b> — Pulse Width Modulator 1, output 1.                                                                                                                                                                             |
| P3[25]/MAT0[0]/PWM1[2]  | M3 <sup>[1]</sup>  | I/O  | <b>P3[25]</b> — General purpose digital input/output pin.                                                                                                                                                                       |
|                         |                    | O    | <b>MAT0[0]</b> — Match output for Timer 0, channel 0.                                                                                                                                                                           |
|                         |                    | O    | <b>PWM1[2]</b> — Pulse Width Modulator 1, output 2.                                                                                                                                                                             |
| P3[26]/MAT0[1]/PWM1[3]  | K7 <sup>[1]</sup>  | I/O  | <b>P3[26]</b> — General purpose digital input/output pin.                                                                                                                                                                       |
|                         |                    | O    | <b>MAT0[1]</b> — Match output for Timer 0, channel 1.                                                                                                                                                                           |
|                         |                    | O    | <b>PWM1[3]</b> — Pulse Width Modulator 1, output 3.                                                                                                                                                                             |
| P4[0] to P4[31]         |                    | I/O  | <b>Port 4:</b> Port 4 is a 32-bit I/O port with individual direction controls for each bit. The operation of port 4 pins depends upon the pin function selected via the Pin Connect block.<br>Pins P4[20:23] are not available. |
| P4[0]/A0                | L6 <sup>[1]</sup>  | I/O  | <b>P4[0]</b> — General purpose digital input/output pin.                                                                                                                                                                        |
|                         |                    | I/O  | <b>A0</b> — External memory address line 0.                                                                                                                                                                                     |
| P4[1]/A1                | M7 <sup>[1]</sup>  | I/O  | <b>P4[1]</b> — General purpose digital input/output pin.                                                                                                                                                                        |
|                         |                    | I/O  | <b>A1</b> — External memory address line 1.                                                                                                                                                                                     |
| P4[2]/A2                | M8 <sup>[1]</sup>  | I/O  | <b>P4[2]</b> — General purpose digital input/output pin.                                                                                                                                                                        |
|                         |                    | I/O  | <b>A2</b> — External memory address line 2.                                                                                                                                                                                     |
| P4[3]/A3                | K9 <sup>[1]</sup>  | I/O  | <b>P4[3]</b> — General purpose digital input/output pin.                                                                                                                                                                        |
|                         |                    | I/O  | <b>A3</b> — External memory address line 3.                                                                                                                                                                                     |
| P4[4]/A4                | P13 <sup>[1]</sup> | I/O  | <b>P4[4]</b> — General purpose digital input/output pin.                                                                                                                                                                        |
|                         |                    | I/O  | <b>A4</b> — External memory address line 4.                                                                                                                                                                                     |
| P4[5]/A5                | H10 <sup>[1]</sup> | I/O  | <b>P4[5]</b> — General purpose digital input/output pin.                                                                                                                                                                        |
|                         |                    | I/O  | <b>A5</b> — External memory address line 5.                                                                                                                                                                                     |
| P4[6]/A6                | K10 <sup>[1]</sup> | I/O  | <b>P4[6]</b> — General purpose digital input/output pin.                                                                                                                                                                        |
|                         |                    | I/O  | <b>A6</b> — External memory address line 6.                                                                                                                                                                                     |
| P4[7]/A7                | K12 <sup>[1]</sup> | I/O  | <b>P4[7]</b> — General purpose digital input/output pin.                                                                                                                                                                        |
|                         |                    | I/O  | <b>A7</b> — External memory address line 7.                                                                                                                                                                                     |
| P4[8]/A8                | J11 <sup>[1]</sup> | I/O  | <b>P4[8]</b> — General purpose digital input/output pin.                                                                                                                                                                        |
|                         |                    | I/O  | <b>A8</b> — External memory address line 8.                                                                                                                                                                                     |
| P4[9]/A9                | H12 <sup>[1]</sup> | I/O  | <b>P4[9]</b> — General purpose digital input/output pin.                                                                                                                                                                        |
|                         |                    | I/O  | <b>A9</b> — External memory address line 9.                                                                                                                                                                                     |
| P4[10]/A10              | G12 <sup>[1]</sup> | I/O  | <b>P4[10]</b> — General purpose digital input/output pin.                                                                                                                                                                       |
|                         |                    | I/O  | <b>A10</b> — External memory address line 10.                                                                                                                                                                                   |
| P4[11]/A11              | F11 <sup>[1]</sup> | I/O  | <b>P4[11]</b> — General purpose digital input/output pin.                                                                                                                                                                       |
|                         |                    | I/O  | <b>A11</b> — External memory address line 11.                                                                                                                                                                                   |

Table 4. Pin description ...continued

| Symbol                         | Ball               | Type | Description                                                                                            |
|--------------------------------|--------------------|------|--------------------------------------------------------------------------------------------------------|
| P4[12]/A12                     | F10 <sup>[1]</sup> | I/O  | <b>P4[12]</b> — General purpose digital input/output pin.                                              |
|                                |                    | I/O  | <b>A12</b> — External memory address line 12.                                                          |
| P4[13]/A13                     | B14 <sup>[1]</sup> | I/O  | <b>P4[13]</b> — General purpose digital input/output pin.                                              |
|                                |                    | I/O  | <b>A13</b> — External memory address line 13.                                                          |
| P4[14]/A14                     | E8 <sup>[1]</sup>  | I/O  | <b>P4[14]</b> — General purpose digital input/output pin.                                              |
|                                |                    | I/O  | <b>A14</b> — External memory address line 14.                                                          |
| P4[15]/A15                     | C10 <sup>[1]</sup> | I/O  | <b>P4[15]</b> — General purpose digital input/output pin.                                              |
|                                |                    | I/O  | <b>A15</b> — External memory address line 15.                                                          |
| P4[16]/A16                     | N12 <sup>[1]</sup> | I/O  | <b>P4[16]</b> — General purpose digital input/output pin.                                              |
|                                |                    | I/O  | <b>A16</b> — External memory address line 16.                                                          |
| P4[17]/A17                     | N13 <sup>[1]</sup> | I/O  | <b>P4[17]</b> — General purpose digital input/output pin.                                              |
|                                |                    | I/O  | <b>A17</b> — External memory address line 17.                                                          |
| P4[18]/A18                     | P14 <sup>[1]</sup> | I/O  | <b>P4[18]</b> — General purpose digital input/output pin.                                              |
|                                |                    | I/O  | <b>A18</b> — External memory address line 18.                                                          |
| P4[19]/A19                     | M14 <sup>[1]</sup> | I/O  | <b>P4[19]</b> — General purpose digital input/output pin.                                              |
|                                |                    | I/O  | <b>A19</b> — External memory address line 19.                                                          |
| P4[24]/ $\overline{\text{OE}}$ | C8 <sup>[1]</sup>  | I/O  | <b>P4[24]</b> — General purpose digital input/output pin.                                              |
|                                |                    | O    | $\overline{\text{OE}}$ — LOW active Output Enable signal.                                              |
| P4[25]/ $\overline{\text{WE}}$ | D9 <sup>[1]</sup>  | I/O  | <b>P4[25]</b> — General purpose digital input/output pin.                                              |
|                                |                    | O    | $\overline{\text{WE}}$ — LOW active Write Enable signal.                                               |
| P4[26]/BLS0                    | K13 <sup>[1]</sup> | I/O  | <b>P4[26]</b> — General purpose digital input/output pin.                                              |
|                                |                    | O    | <b>BLS0</b> — LOW active Byte Lane select signal 0.                                                    |
| P4[27]/BLS1                    | F14 <sup>[1]</sup> | I/O  | <b>P4[27]</b> — General purpose digital input/output pin.                                              |
|                                |                    | O    | <b>BLS1</b> — LOW active Byte Lane select signal 1.                                                    |
| P4[28]/MAT2[0]/<br>TXD3        | D10 <sup>[1]</sup> | I/O  | <b>P4[28]</b> — General purpose digital input/output pin.                                              |
|                                |                    | O    | <b>MAT2[0]</b> — Match output for Timer 2, channel 0.                                                  |
|                                |                    | O    | <b>TXD3</b> — Transmitter output for UART3.                                                            |
| P4[29]/MAT2[1]/<br>RXD3        | B9 <sup>[1]</sup>  | I/O  | <b>P4[29]</b> — General purpose digital input/output pin.                                              |
|                                |                    | O    | <b>MAT2[1]</b> — Match output for Timer 2, channel 1.                                                  |
|                                |                    | I    | <b>RXD3</b> — Receiver input for UART3.                                                                |
| P4[30]/CS0                     | C7 <sup>[1]</sup>  | I/O  | <b>P4[30]</b> — General purpose digital input/output pin.                                              |
|                                |                    | O    | <b>CS0</b> — LOW active Chip Select 0 signal.                                                          |
| P4[31]/CS1                     | E7 <sup>[1]</sup>  | I/O  | <b>P4[31]</b> — General purpose digital input/output pin.                                              |
|                                |                    | O    | <b>CS1</b> — LOW active Chip Select 1 signal.                                                          |
| ALARM                          | H5 <sup>[8]</sup>  | O    | <b>ALARM</b> — RTC controlled output. This is a 1.8 V pin. It goes HIGH when a RTC alarm is generated. |
| USB_D-2                        | N2                 | I/O  | <b>USB_D-2</b> — USB port 2 bidirectional D- line.                                                     |
| DBGEN                          | E5 <sup>[1]</sup>  | I    | <b>DBGEN</b> — JTAG interface control signal. Also used for boundary scan.                             |
| TDO                            | B1 <sup>[1]</sup>  | O    | <b>TDO</b> — Test Data Out for JTAG interface.                                                         |
| TDI                            | C3 <sup>[1]</sup>  | I    | <b>TDI</b> — Test Data In for JTAG interface.                                                          |
| TMS                            | C2 <sup>[1]</sup>  | I    | <b>TMS</b> — Test Mode Select for JTAG interface.                                                      |

Table 4. Pin description ...continued

| Symbol                     | Ball                                                             | Type | Description                                                                                                                                                                                                            |
|----------------------------|------------------------------------------------------------------|------|------------------------------------------------------------------------------------------------------------------------------------------------------------------------------------------------------------------------|
| TRST                       | D4 <sup>[1]</sup>                                                | I    | <b>TRST</b> — Test Reset for JTAG interface.                                                                                                                                                                           |
| TCK                        | D2 <sup>[1]</sup>                                                | I    | <b>TCK</b> — Test Clock for JTAG interface. This clock must be slower than $\frac{1}{6}$ of the CPU clock (CCLK) for the JTAG interface to operate.                                                                    |
| RTCK                       | C4 <sup>[1]</sup>                                                | I/O  | <b>RTCK</b> — JTAG interface control signal.<br><b>Note:</b> LOW on this pin while <b>RESET</b> is LOW enables ETM pins (P2[9:0]) to operate as Trace port after reset.                                                |
| RSTOUT                     | H2                                                               | O    | <b>RSTOUT</b> — This is a 3.3 V pin. LOW on this pin indicates LPC2458 being in Reset state.                                                                                                                           |
| RESET                      | J1 <sup>[7]</sup>                                                | I    | <b>external reset input:</b> A LOW on this pin resets the device, causing I/O ports and peripherals to take on their default states, and processor execution to begin at address 0. TTL with hysteresis, 5 V tolerant. |
| XTAL1                      | L2 <sup>[8]</sup>                                                | I    | Input to the oscillator circuit and internal clock generator circuits.                                                                                                                                                 |
| XTAL2                      | K4 <sup>[8]</sup>                                                | O    | Output from the oscillator amplifier.                                                                                                                                                                                  |
| RTCX1                      | J2 <sup>[8]</sup>                                                | I    | Input to the RTC oscillator circuit.                                                                                                                                                                                   |
| RTCX2                      | J3 <sup>[8]</sup>                                                | O    | Output from the RTC oscillator circuit.                                                                                                                                                                                |
| V <sub>SSIO</sub>          | H4, P4,<br>L9, L13,<br>G13,<br>D13,<br>C11,<br>B4 <sup>[9]</sup> | I    | <b>ground:</b> 0 V reference for the digital IO pins.                                                                                                                                                                  |
| V <sub>SSCORE</sub>        | H3, L8,<br>A10 <sup>[9]</sup>                                    | I    | <b>ground:</b> 0 V reference for the core.                                                                                                                                                                             |
| V <sub>SSA</sub>           | F3 <sup>[10]</sup>                                               | I    | <b>analog ground:</b> 0 V reference. This should nominally be the same voltage as V <sub>SSIO</sub> /V <sub>SSCORE</sub> , but should be isolated to minimize noise and error.                                         |
| V <sub>DD(3V3)</sub>       | E2, L4,<br>K8, L11,<br>J14, E12,<br>E10,<br>C5 <sup>[11]</sup>   | I    | <b>3.3 V supply voltage:</b> This is the power supply voltage for the I/O ports.                                                                                                                                       |
| n.c.                       | H1, L12,<br>G10 <sup>[12]</sup>                                  | I    | <b>not connected pins:</b> These pins must be left unconnected (floating).                                                                                                                                             |
| V <sub>DD(DCDC)(3V3)</sub> | G1, N9,<br>E9 <sup>[13]</sup>                                    | I    | <b>3.3 V DC-to-DC converter supply voltage:</b> This is the power supply for the on-chip DC-to-DC converter.                                                                                                           |
| V <sub>DDA</sub>           | F2 <sup>[14]</sup>                                               | I    | <b>analog 3.3 V pad supply voltage:</b> This should be nominally the same voltage as V <sub>DD(3V3)</sub> but should be isolated to minimize noise and error. This voltage is used to power the ADC and DAC.           |
| VREF                       | G2 <sup>[14]</sup>                                               | I    | <b>ADC reference:</b> This should be nominally the same voltage as V <sub>DD(3V3)</sub> but should be isolated to minimize noise and error. The level on this pin is used as a reference for ADC and DAC.              |
| VBAT                       | K1 <sup>[14]</sup>                                               | I    | <b>RTC power supply:</b> 3.3 V on this pin supplies the power to the RTC peripheral.                                                                                                                                   |

[1] 5 V tolerant pad providing digital I/O functions with TTL levels and hysteresis.

[2] 5 V tolerant pad providing digital I/O functions (with TTL levels and hysteresis) and analog input. When configured as a ADC input, digital section of the pad is disabled.

[3] 5 V tolerant pad providing digital I/O with TTL levels and hysteresis and analog output function. When configured as the DAC output, digital section of the pad is disabled.

- [4] Open-drain 5 V tolerant digital I/O pad, compatible with I<sup>2</sup>C-bus 400 kHz specification. It requires an external pull-up to provide output functionality. When power is switched off, this pin connected to the I<sup>2</sup>C-bus is floating and does not disturb the I<sup>2</sup>C lines. Open-drain configuration applies to all functions on this pin.
- [5] Pad provides digital I/O and USB functions. It is designed in accordance with the *USB specification, revision 2.0* (Full-speed and Low-speed mode only).
- [6] 5 V tolerant pad with 5 ns glitch filter providing digital I/O functions with TTL levels and hysteresis.
- [7] 5 V tolerant pad with 20 ns glitch filter providing digital I/O function with TTL levels and hysteresis.
- [8] Pad provides special analog functionality.
- [9] Pad provides special analog functionality.
- [10] Pad provides special analog functionality.
- [11] Pad provides special analog functionality.
- [12] Pad provides special analog functionality.
- [13] Pad provides special analog functionality.
- [14] Pad provides special analog functionality.

## 7. Functional description

### 7.1 Architectural overview

The LPC2458 microcontroller consists of an ARM7TDMI-S CPU with emulation support, the ARM7 local bus for closely coupled, high-speed access to the majority of on-chip memory, the AMBA AHB interfacing to high-speed on-chip peripherals and external memory, and the AMBA APB for connection to other on-chip peripheral functions. The microcontroller permanently configures the ARM7TDMI-S processor for little-endian byte order.

The LPC2458 implements two AHB in order to allow the Ethernet block to operate without interference caused by other system activity. The primary AHB, referred to as AHB1, includes the VIC, GPDMA controller, and EMC.

The second AHB, referred to as AHB2, includes only the Ethernet block and an associated 16 kB SRAM. In addition, a bus bridge is provided that allows the secondary AHB to be a bus master on AHB1, allowing expansion of Ethernet buffer space into off-chip memory or unused space in memory residing on AHB1.

In summary, bus masters with access to AHB1 are the ARM7 itself, the GPDMA function, and the Ethernet block (via the bus bridge from AHB2). Bus masters with access to AHB2 are the ARM7 and the Ethernet block.

AHB peripherals are allocated a 2 MB range of addresses at the very top of the 4 GB ARM memory space. Each AHB peripheral is allocated a 16 kB address space within the AHB address space. Lower speed peripheral functions are connected to the APB. The AHB to APB bridge interfaces the APB to the AHB. APB peripherals are also allocated a 2 MB range of addresses, beginning at the 3.5 GB address point. Each APB peripheral is allocated a 16 kB address space within the APB address space.

The ARM7TDMI-S processor is a general purpose 32-bit microprocessor, which offers high performance and very low power consumption. The ARM architecture is based on Reduced Instruction Set Computer (RISC) principles, and the instruction set and related decode mechanism are much simpler than those of microprogrammed complex instruction set computers. This simplicity results in a high instruction throughput and impressive real-time interrupt response from a small and cost-effective processor core.

Pipeline techniques are employed so that all parts of the processing and memory systems can operate continuously. Typically, while one instruction is being executed, its successor is being decoded, and a third instruction is being fetched from memory.

The ARM7TDMI-S processor also employs a unique architectural strategy known as Thumb, which makes it ideally suited to high-volume applications with memory restrictions, or applications where code density is an issue.

The key idea behind Thumb is that of a super-reduced instruction set. Essentially, the ARM7TDMI-S processor has two instruction sets:

- the standard 32-bit ARM set
- a 16-bit Thumb set

The Thumb set's 16-bit instruction length allows it to approach higher density compared to standard ARM code while retaining most of the ARM's performance.

## 7.2 On-chip flash programming memory

The LPC2458 incorporates 512 kB flash memory system. This memory may be used for both code and data storage. Programming of the flash memory may be accomplished in several ways. It may be programmed In System via the serial port (UART0). The application program may also erase and/or program the flash while the application is running, allowing a great degree of flexibility for data storage field and firmware upgrades.

The flash memory is 128 bits wide and includes pre-fetching and buffering techniques to allow it to operate at speeds of 72 MHz.

The LPC2458 provides a minimum of 100000 write/erase cycles and 20 years of data retention.

## 7.3 On-chip SRAM

The LPC2458 includes a SRAM memory of 64 kB reserved for the ARM processor exclusive use. This RAM may be used for code and/or data storage and may be accessed as 8 bits, 16 bits, and 32 bits.

A 16 kB SRAM block serving as a buffer for the Ethernet controller and a 16 kB SRAM associated with the second AHB can be used both for data and code storage, too. The 2 kB RTC SRAM can be used for data storage only. The RTC SRAM is battery powered and retains the content in the absence of the main power supply.

## 7.4 Memory map

The LPC2458 memory map incorporates several distinct regions as shown in [Table 5](#) and [Figure 3](#).

In addition, the CPU interrupt vectors may be remapped to allow them to reside in either flash memory (default), boot ROM, or SRAM (see [Section 7.26.6](#)).

Table 5. LPC2458 memory usage and details

| Address range                 | General use                                       | Address range details and description |                       |
|-------------------------------|---------------------------------------------------|---------------------------------------|-----------------------|
| 0x0000 0000 to<br>0x3FFF FFFF | on-chip<br>non-volatile<br>memory and fast<br>I/O | 0x0000 0000 to 0x0007 FFFF            | flash memory (512 kB) |
|                               |                                                   | 0x3FFF C000 to 0x3FFF FFFF            | fast GPIO registers   |
| 0x4000 0000 to<br>0x7FFF FFFF | on-chip RAM                                       | 0x4000 0000 to 0x4000 FFFF            | RAM (64 kB)           |
|                               |                                                   | 0x7FE0 0000 to 0x7FE0 3FFF            | Ethernet RAM (16 kB)  |
|                               |                                                   | 0x7FD0 0000 to 0x7FD0 3FFF            | USB RAM (16 kB)       |
| 0x8000 0000 to<br>0xBFFF FFFF | off-chip memory                                   | two static memory banks, 16 MB each   |                       |
|                               |                                                   | 0x8000 0000 to 0x80FF FFFF            | static memory bank 0  |
|                               |                                                   | 0x8100 0000 to 0x81FF FFFF            | static memory bank 1  |
|                               |                                                   | two dynamic memory banks, 256 MB each |                       |
|                               |                                                   | 0xA000 0000 to 0xAFFF FFFF            | dynamic memory bank 0 |
|                               |                                                   | 0xB000 0000 to 0xBFFF FFFF            | dynamic memory bank 1 |
| 0xE000 0000 to<br>0xEFFF FFFF | APB peripherals                                   | 36 peripheral blocks, 16 kB each      |                       |
| 0xF000 0000 to<br>0xFFFF FFFF | AHB peripherals                                   |                                       |                       |

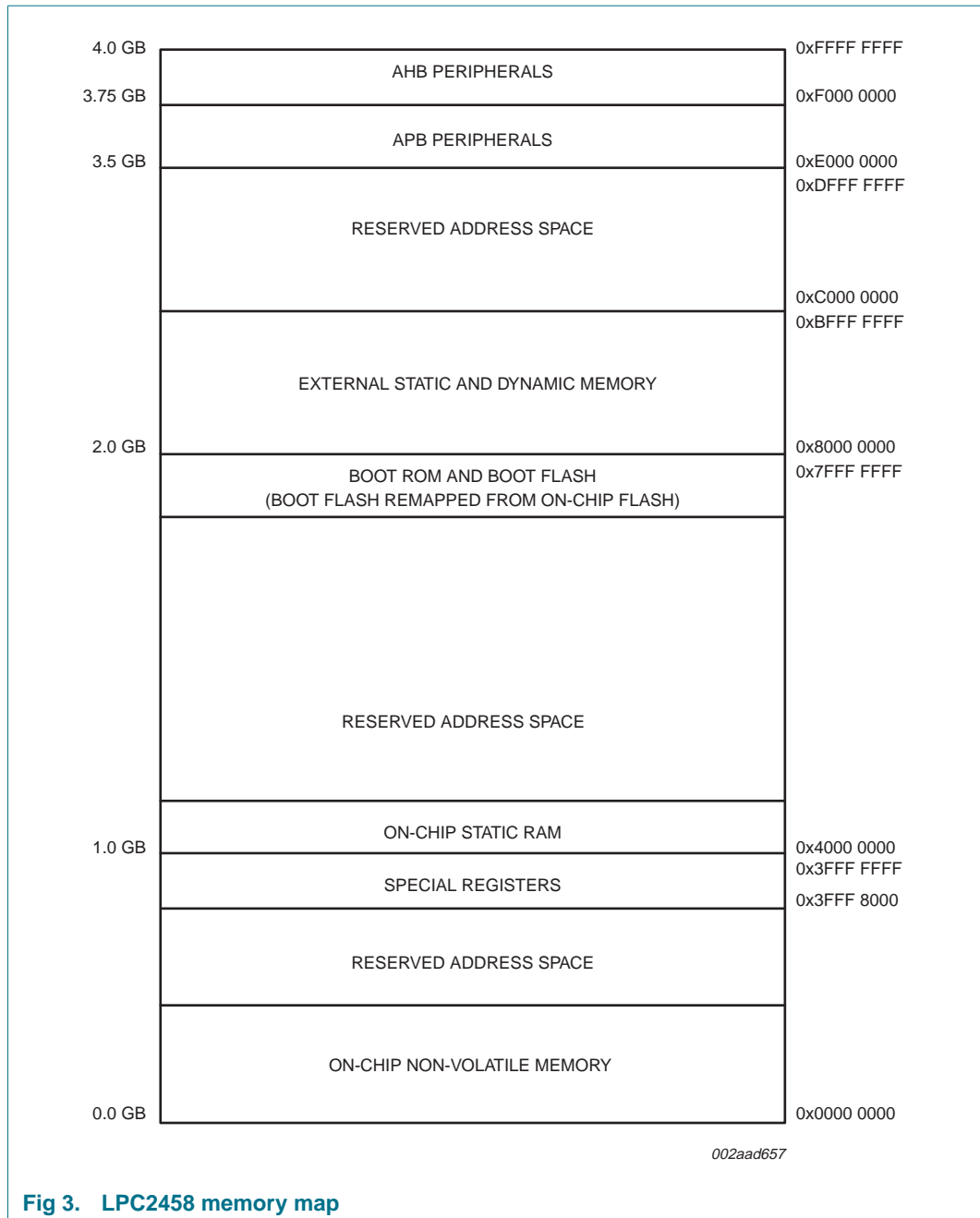

### 7.5 Interrupt controller

The ARM processor core has two interrupt inputs called Interrupt Request (IRQ) and Fast Interrupt Request (FIQ). The VIC takes 32 interrupt request inputs which can be programmed as FIQ or vectored IRQ types. The programmable assignment scheme means that priorities of interrupts from the various peripherals can be dynamically assigned and adjusted.

FIQs have the highest priority. If more than one request is assigned to FIQ, the VIC ORs the requests to produce the FIQ signal to the ARM processor. The fastest possible FIQ latency is achieved when only one request is classified as FIQ, because then the FIQ

service routine can simply start dealing with that device. But if more than one request is assigned to the FIQ class, the FIQ service routine can read a word from the VIC that identifies which FIQ source(s) is (are) requesting an interrupt.

Vectored IRQs, which include all interrupt requests that are not classified as FIQs, have a programmable interrupt priority. When more than one interrupt is assigned the same priority and occur simultaneously, the one connected to the lowest numbered VIC channel will be serviced first.

The VIC ORs the requests from all of the vectored IRQs to produce the IRQ signal to the ARM processor. The IRQ service routine can start by reading a register from the VIC and jumping to the address supplied by that register.

### 7.5.1 Interrupt sources

Each peripheral device has one interrupt line connected to the VIC but may have several interrupt flags. Individual interrupt flags may also represent more than one interrupt source.

Any pin on port 0 and port 2 (total of 64 pins) regardless of the selected function, can be programmed to generate an interrupt on a rising edge, a falling edge, or both. Such interrupt request coming from port 0 and/or port 2 will be combined with the  $EINT3$  interrupt requests.

## 7.6 Pin connect block

The pin connect block allows selected pins of the microcontroller to have more than one function. Configuration registers control the multiplexers to allow connection between the pin and the on chip peripherals.

Peripherals should be connected to the appropriate pins prior to being activated and prior to any related interrupt(s) being enabled. Activity of any enabled peripheral function that is not mapped to a related pin should be considered undefined.

## 7.7 External memory controller

The LPC2458 EMC is an ARM PrimeCell MultiPort Memory Controller peripheral offering support for asynchronous static memory devices such as RAM, ROM, and flash. In addition, it can be used as an interface with off-chip memory-mapped devices and peripherals. The EMC is an Advanced Microcontroller Bus Architecture (AMBA) compliant peripheral.

### 7.7.1 Features

- Dynamic memory interface support including Single Data Rate SDRAM.
- Asynchronous static memory device support including RAM, ROM, and flash, with or without asynchronous page mode.
- Low transaction latency.
- Read and write buffers to reduce latency and to improve performance.
- 8/16 data and 20 address lines wide static memory support.
- 16 bit wide chip select SDRAM memory support.



- Static memory features include:
  - Asynchronous page mode read
  - Programmable Wait States
  - Bus turnaround delay
  - Output enable and write enable delays
  - Extended wait
- Two chip selects for synchronous memory and two chip selects for static memory devices.
- Power-saving modes dynamically control CKE and CLKOUT to SDRAMs.
- Dynamic memory self-refresh mode controlled by software.
- Controller supports 2048 (A0 to A10), 4096 (A0 to A11), and 8192 (A0 to A12) row address synchronous memory parts. That is typical 512 MB, 256 MB, and 128 MB parts, with 4, 8, and 16 data bits per device.
- Separate reset domains allow auto-refresh through a chip reset if desired.

**Note:** Synchronous static memory devices (synchronous burst mode) are not supported.

## 7.8 General purpose DMA controller

The GPDMA is an AMBA AHB compliant peripheral allowing selected LPC2458 peripherals to have DMA support.

The GPDMA enables peripheral-to-memory, memory-to-peripheral, peripheral-to-peripheral, and memory-to-memory transactions. Each DMA stream provides unidirectional serial DMA transfers for a single source and destination. For example, a bidirectional port requires one stream for transmit and one for receive. The source and destination areas can each be either a memory region or a peripheral, and can be accessed through the AHB master.

### 7.8.1 Features

- Two DMA channels. Each channel can support a unidirectional transfer.
- The GPDMA can transfer data between the 16 kB SRAM, external memory, and peripherals such as the SD/MMC, two SSPs, and the I<sup>2</sup>S interface.
- Single DMA and burst DMA request signals. Each peripheral connected to the GPDMA can assert either a burst DMA request or a single DMA request. The DMA burst size is set by programming the GPDMA.
- Memory-to-memory, memory-to-peripheral, peripheral-to-memory, and peripheral-to-peripheral transfers.
- Scatter or gather DMA is supported through the use of linked lists. This means that the source and destination areas do not have to occupy contiguous areas of memory.
- Hardware DMA channel priority. Each DMA channel has a specific hardware priority. DMA channel 0 has the highest priority and channel 1 has the lowest priority. If requests from two channels become active at the same time, the channel with the highest priority is serviced first.
- AHB slave DMA programming interface. The GPDMA is programmed by writing to the DMA control registers over the AHB slave interface.

- One AHB master for transferring data. This interface transfers data when a DMA request goes active.
- 32-bit AHB master bus width.
- Incrementing or non-incrementing addressing for source and destination.
- Programmable DMA burst size. The DMA burst size can be programmed to more efficiently transfer data. Usually the burst size is set to half the size of the FIFO in the peripheral.
- Internal four-word FIFO per channel.
- Supports 8-bit, 16-bit, and 32-bit wide transactions.
- An interrupt to the processor can be generated on a DMA completion or when a DMA error has occurred.
- Interrupt masking. The DMA error and DMA terminal count interrupt requests can be masked.
- Raw interrupt status. The DMA error and DMA count raw interrupt status can be read prior to masking.

## 7.9 Fast general purpose parallel I/O

Device pins that are not connected to a specific peripheral function are controlled by the GPIO registers. Pins may be dynamically configured as inputs or outputs. Separate registers allow setting or clearing any number of outputs simultaneously. The value of the output register may be read back as well as the current state of the port pins.

LPC2458 use accelerated GPIO functions:

- GPIO registers are relocated to the ARM local bus so that the fastest possible I/O timing can be achieved.
- Mask registers allow treating sets of port bits as a group, leaving other bits unchanged.
- All GPIO registers are byte and half-word addressable.
- Entire port value can be written in one instruction.

Additionally, any pin on port 0 and port 2 (total of 64 pins) that is not configured as an analog input/output can be programmed to generate an interrupt on a rising edge, a falling edge, or both. The edge detection is asynchronous, so it may operate when clocks are not present such as during Power-down mode. Each enabled interrupt can be used to wake the chip up from Power-down mode.

### 7.9.1 Features

- Bit level set and clear registers allow a single instruction to set or clear any number of bits in one port.
- Direction control of individual bits.
- All I/O default to inputs after reset.
- Backward compatibility with other earlier devices is maintained with legacy port 0 and port 1 registers appearing at the original addresses on the APB.

## 7.10 Ethernet

The Ethernet block contains a full featured 10 Mbit/s or 100 Mbit/s Ethernet MAC designed to provide optimized performance through the use of DMA hardware acceleration. Features include a generous suite of control registers, half or full duplex operation, flow control, control frames, hardware acceleration for transmit retry, receive packet filtering and wake-up on LAN activity. Automatic frame transmission and reception with scatter-gather DMA off-loads many operations from the CPU.

The Ethernet block and the CPU share a dedicated AHB subsystem that is used to access the Ethernet SRAM for Ethernet data, control, and status information. All other AHB traffic in the LPC2458 takes place on a different AHB subsystem, effectively separating Ethernet activity from the rest of the system. The Ethernet DMA can also access off-chip memory via the EMC, as well as the SRAM located on another AHB. However, using memory other than the Ethernet SRAM, especially off-chip memory, will slow Ethernet access to memory and increase the loading of its AHB.

The Ethernet block interfaces between an off-chip Ethernet PHY using the Media Independent Interface (MII) or Reduced MII (RMII) protocol and the on-chip Media Independent Interface Management (MIIM) serial bus.

### 7.10.1 Features

- Ethernet standards support:
  - Supports 10 Mbit/s or 100 Mbit/s PHY devices including 10 Base-T, 100 Base-TX, 100 Base-FX, and 100 Base-T4.
  - Fully compliant with IEEE standard 802.3.
  - Fully compliant with 802.3x full duplex flow control and half duplex back pressure.
  - Flexible transmit and receive frame options.
  - Virtual Local Area Network (VLAN) frame support.
- Memory management:
  - Independent transmit and receive buffers memory mapped to shared SRAM.
  - DMA managers with scatter/gather DMA and arrays of frame descriptors.
  - Memory traffic optimized by buffering and pre-fetching.
- Enhanced Ethernet features:
  - Receive filtering.
  - Multicast and broadcast frame support for both transmit and receive.
  - Optional automatic Frame Check Sequence (FCS) insertion with Circular Redundancy Check (CRC) for transmit.
  - Selectable automatic transmit frame padding.
  - Over-length frame support for both transmit and receive allows any length frames.
  - Promiscuous receive mode.
  - Automatic collision back-off and frame retransmission.
  - Includes power management by clock switching.
  - Wake-on-LAN power management support allows system wake-up: using the receive filters or a magic frame detection filter.

- Physical interface:
  - Attachment of external PHY chip through standard MII or RMI interface.
  - PHY register access is available via the MIIM interface.

## 7.11 USB interface

The Universal Serial Bus (USB) is a 4-wire bus that supports communication between a host and one or more (up to 127) peripherals. The Host Controller allocates the USB bandwidth to attached devices through a token-based protocol. The bus supports hot plugging and dynamic configuration of the devices. All transactions are initiated by the Host Controller.

The LPC2458 USB interface includes a device, Host, and OTG Controller. Details on typical USB interfacing solutions can be found in [Section 11.1 “Suggested USB interface solutions” on page 56](#)

### 7.11.1 USB device controller

The device controller enables 12 Mbit/s data exchange with a USB Host Controller. It consists of a register interface, serial interface engine, endpoint buffer memory, and a DMA controller. The serial interface engine decodes the USB data stream and writes data to the appropriate endpoint buffer. The status of a completed USB transfer or error condition is indicated via status registers. An interrupt is also generated if enabled. When enabled, the DMA controller transfers data between the endpoint buffer and the USB RAM.

#### 7.11.1.1 Features

- Fully compliant with *USB 2.0 specification* (full speed).
- Supports 32 physical (16 logical) endpoints with a 4 kB endpoint buffer RAM.
- Supports Control, Bulk, Interrupt and Isochronous endpoints.
- Scalable realization of endpoints at run time.
- Endpoint Maximum packet size selection (up to USB maximum specification) by software at run time.
- Supports SoftConnect and GoodLink features.
- While USB is in the Suspend mode, LPC2458 can enter one of the reduced power modes and wake up on USB activity.
- Supports DMA transfers with the DMA RAM of 16 kB on all non-control endpoints.
- Allows dynamic switching between CPU-controlled and DMA modes.
- Double buffer implementation for Bulk and Isochronous endpoints.

### 7.11.2 USB Host Controller

The Host Controller enables full- and low-speed data exchange with USB devices attached to the bus. It consists of a register interface, a serial interface engine and a DMA controller. The register interface complies with the OHCI specification.

#### 7.11.2.1 Features

- OHCI compliant.

- Two downstream ports.
- Supports per-port power switching.

### 7.11.3 USB OTG Controller

USB OTG is a supplement to the USB 2.0 specification that augments the capability of existing mobile devices and USB peripherals by adding host functionality for connection to USB peripherals.

The OTG Controller integrates the Host Controller, device controller, and a master-only I<sup>2</sup>C interface to implement OTG dual-role device functionality. The dedicated I<sup>2</sup>C interface controls an external OTG transceiver.

#### 7.11.3.1 Features

- Fully compliant with On-The-Go supplement to the *USB 2.0 Specification, Revision 1.0a*.
- Hardware support for Host Negotiation Protocol (HNP).
- Includes a programmable timer required for HNP and Session Request Protocol (SRP).
- Supports any OTG transceiver compliant with the *OTG Transceiver Specification (CEA-2011), Rev. 1.0*.

## 7.12 CAN controller and acceptance filters

The Controller Area Network (CAN) is a serial communications protocol which efficiently supports distributed real-time control with a very high level of security. Its domain of application ranges from high-speed networks to low cost multiplex wiring.

The CAN block is intended to support multiple CAN buses simultaneously, allowing the device to be used as a gateway, switch, or router between two of CAN buses in industrial or automotive applications.

Each CAN controller has a register structure similar to the NXP SJA1000 and the PeliCAN Library block, but the 8-bit registers of those devices have been combined in 32-bit words to allow simultaneous access in the ARM environment. The main operational difference is that the recognition of received Identifiers, known in CAN terminology as Acceptance Filtering, has been removed from the CAN controllers and centralized in a global Acceptance Filter.

### 7.12.1 Features

- Two CAN controllers and buses.
- Data rates to 1 Mbit/s on each bus.
- 32-bit register and RAM access.
- Compatible with *CAN specification 2.0B, ISO 11898-1*.
- Global Acceptance Filter recognizes 11-bit and 29-bit receive identifiers for all CAN buses.
- Acceptance Filter can provide FullCAN-style automatic reception for selected Standard Identifiers.
- Full CAN messages can generate interrupts.

### 7.13 10-bit ADC

The LPC2458 contains one ADC. It is a single 10-bit successive approximation ADC with eight channels.

#### 7.13.1 Features

- 10-bit successive approximation ADC
- Input multiplexing among 8 pins
- Power-down mode
- Measurement range 0 V to  $V_{i(VREF)}$
- 10-bit conversion time  $\geq 2.44 \mu\text{s}$
- Burst conversion mode for single or multiple inputs
- Optional conversion on transition of input pin or Timer Match signal
- Individual result registers for each ADC channel to reduce interrupt overhead

### 7.14 10-bit DAC

The DAC allows the LPC2458 to generate a variable analog output. The maximum output value of the DAC is  $V_{i(VREF)}$ .

#### 7.14.1 Features

- 10-bit DAC
- Resistor string architecture
- Buffered output
- Power-down mode
- Selectable output drive

### 7.15 UARTs

The LPC2458 contains four UARTs. In addition to standard transmit and receive data lines, UART1 also provides a full modem control handshake interface.

The UARTs include a fractional baud rate generator. Standard baud rates such as 115200 Bd can be achieved with any crystal frequency above 2 MHz.

#### 7.15.1 Features

- 16 B Receive and Transmit FIFOs.
- Register locations conform to 16C550 industry standard.
- Receiver FIFO trigger points at 1 B, 4 B, 8 B, and 14 B.
- Built-in fractional baud rate generator covering wide range of baud rates without a need for external crystals of particular values.
- Fractional divider for baud rate control, auto baud capabilities and FIFO control mechanism that enables software flow control implementation.
- UART1 equipped with standard modem interface signals. This module also provides full support for hardware flow control (auto-CTS/RTS).

- UART3 includes an IrDA mode to support infrared communication.

## 7.16 SPI serial I/O controller

The LPC2458 contains one SPI controller. SPI is a full duplex serial interface designed to handle multiple masters and slaves connected to a given bus. Only a single master and a single slave can communicate on the interface during a given data transfer. During a data transfer the master always sends 8 bits to 16 bits of data to the slave, and the slave always sends 8 bits to 16 bits of data to the master.

### 7.16.1 Features

- Compliant with SPI specification
- Synchronous, Serial, Full Duplex Communication
- Combined SPI master and slave
- Maximum data bit rate of one eighth of the input clock rate
- 8 bits to 16 bits per transfer

## 7.17 SSP serial I/O controller

The LPC2458 contains two SSP controllers. The SSP controller is capable of operation on a SPI, 4-wire SSI, or Microwire bus. It can interact with multiple masters and slaves on the bus. Only a single master and a single slave can communicate on the bus during a given data transfer. The SSP supports full duplex transfers, with frames of 4 bits to 16 bits of data flowing from the master to the slave and from the slave to the master. In practice, often only one of these data flows carries meaningful data.

### 7.17.1 Features

- Compatible with Motorola SPI, 4-wire Texas Instruments SSI, and National Semiconductor Microwire buses
- Synchronous serial communication
- Master or slave operation
- 8-frame FIFOs for both transmit and receive
- 4-bit to 16-bit frame
- Maximum SPI bus data bit rate of one half (Master mode) and one twelfth (Slave mode) of the input clock rate
- DMA transfers supported by GPDMA

## 7.18 SD/MMC card interface

The Secure Digital and Multimedia Card Interface (MCI) allows access to external SD memory cards. The SD card interface conforms to the *SD Multimedia Card Specification Version 2.11*.

### 7.18.1 Features

- The MCI interface provides all functions specific to the SD/MMC memory card. These include the clock generation unit, power management control, and command and data transfer.

- Conforms to *Multimedia Card Specification v2.11*.
- Conforms to *Secure Digital Memory Card Physical Layer Specification, v0.96*.
- Can be used as a multimedia card bus or a secure digital memory card bus host. The SD/MMC can be connected to several multimedia cards or a single secure digital memory card.
- DMA supported through the GPDMA controller.

## 7.19 I<sup>2</sup>C-bus serial I/O controller

The LPC2458 contains three I<sup>2</sup>C-bus controllers.

The I<sup>2</sup>C-bus is bidirectional, for inter-IC control using only two wires: a serial clock line (SCL), and a serial data line (SDA). Each device is recognized by a unique address and can operate as either a receiver-only device (e.g., an LCD driver) or a transmitter with the capability to both receive and send information (such as memory). Transmitters and/or receivers can operate in either master or slave mode, depending on whether the chip has to initiate a data transfer or is only addressed. The I<sup>2</sup>C-bus is a multi-master bus and can be controlled by more than one bus master connected to it.

The I<sup>2</sup>C-bus implemented in LPC2458 supports bit rates up to 400 kbit/s (Fast I<sup>2</sup>C-bus).

### 7.19.1 Features

- I<sup>2</sup>C0 is a standard I<sup>2</sup>C compliant bus interface with open-drain pins.
- I<sup>2</sup>C1 and I<sup>2</sup>C2 use standard I/O pins and do not support powering off of individual devices connected to the same bus lines.
- Easy to configure as master, slave, or master/slave.
- Programmable clocks allow versatile rate control.
- Bidirectional data transfer between masters and slaves.
- Multi-master bus (no central master).
- Arbitration between simultaneously transmitting masters without corruption of serial data on the bus.
- Serial clock synchronization allows devices with different bit rates to communicate via one serial bus.
- Serial clock synchronization can be used as a handshake mechanism to suspend and resume serial transfer.
- The I<sup>2</sup>C-bus can be used for test and diagnostic purposes.

## 7.20 I<sup>2</sup>S-bus serial I/O controllers

The I<sup>2</sup>S-bus provides a standard communication interface for digital audio applications.

The I<sup>2</sup>S-bus specification defines a 3-wire serial bus using one data line, one clock line, and one word select signal. The basic I<sup>2</sup>S connection has one master, which is always the master, and one slave. The I<sup>2</sup>S interface on the LPC2458 provides a separate transmit and receive channel, each of which can operate as either a master or a slave.



### 7.20.1 Features

- The interface has separate input/output channels each of which can operate in master or slave mode.
- Capable of handling 8-bit, 16-bit, and 32-bit word sizes.
- Mono and stereo audio data supported.
- The sampling frequency can range from 16 kHz to 48 kHz (16, 22.05, 32, 44.1, 48) kHz.
- Configurable word select period in master mode (separately for I<sup>2</sup>S input and output).
- Two 8 word FIFO data buffers are provided, one for transmit and one for receive.
- Generates interrupt requests when buffer levels cross a programmable boundary.
- Two DMA requests, controlled by programmable buffer levels. These are connected to the GPDMA block.
- Controls include reset, stop and mute options separately for I<sup>2</sup>S input and I<sup>2</sup>S output.

### 7.21 General purpose 32-bit timers/external event counters

The LPC2458 includes four 32-bit Timer/Counters. The Timer/Counter is designed to count cycles of the system derived clock or an externally-supplied clock. It can optionally generate interrupts or perform other actions at specified timer values, based on four match registers. The Timer/Counter also includes four capture inputs to trap the timer value when an input signal transitions, optionally generating an interrupt.

#### 7.21.1 Features

- A 32-bit Timer/Counter with a programmable 32-bit prescaler.
- Counter or Timer operation.
- Up to four 32-bit capture channels per timer, that can take a snapshot of the timer value when an input signal transitions. A capture event may also optionally generate an interrupt.
- Four 32-bit match registers that allow:
  - Continuous operation with optional interrupt generation on match.
  - Stop timer on match with optional interrupt generation.
  - Reset timer on match with optional interrupt generation.
- Up to four external outputs corresponding to match registers, with the following capabilities:
  - Set LOW on match.
  - Set HIGH on match.
  - Toggle on match.
  - Do nothing on match.

## 7.22 Pulse width modulator

The PWM is based on the standard Timer block and inherits all of its features, although only the PWM function is pinned out on the LPC2458. The Timer is designed to count cycles of the system derived clock and optionally switch pins, generate interrupts or perform other actions when specified timer values occur, based on seven match registers. The PWM function is in addition to these features and is based on match register events.

The ability to separately control rising and falling edge locations allows the PWM to be used for more applications. For instance, multi-phase motor control typically requires three non-overlapping PWM outputs with individual control of all three pulse widths and positions.

Two match registers can be used to provide a single edge controlled PWM output. A dedicated match register controls the PWM cycle rate, by resetting the count upon match. The other match register controls the PWM edge position. Additional single edge controlled PWM outputs require only one match register each, since the repetition rate is the same for all PWM outputs. Multiple single edge controlled PWM outputs will all have a rising edge at the beginning of each PWM cycle, when an PWMMR0 match occurs.

Three match registers can be used to provide a PWM output with both edges controlled. Again, a dedicated match register controls the PWM cycle rate. The other match registers control the two PWM edge positions. Additional double edge controlled PWM outputs require only two match registers each, since the repetition rate is the same for all PWM outputs.

With double edge controlled PWM outputs, specific match registers control the rising and falling edge of the output. This allows both positive going PWM pulses (when the rising edge occurs prior to the falling edge), and negative going PWM pulses (when the falling edge occurs prior to the rising edge).

### 7.22.1 Features

- LPC2458 has two PWMs with the same operational features. These may be operated in a synchronized fashion by setting them both up to run at the same rate, then enabling both simultaneously. PWM0 acts as the master and PWM1 as the slave for this use.
- Counter or Timer operation (may use the peripheral clock or one of the capture inputs as the clock source).
- Seven match registers allow up to 6 single edge controlled or 3 double edge controlled PWM outputs, or a mix of both types. The match registers also allow:
  - Continuous operation with optional interrupt generation on match.
  - Stop timer on match with optional interrupt generation.
  - Reset timer on match with optional interrupt generation.
- Supports single edge controlled and/or double edge controlled PWM outputs. Single edge controlled PWM outputs all go high at the beginning of each cycle unless the output is a constant low. Double edge controlled PWM outputs can have either edge occur at any position within a cycle. This allows for both positive going and negative going pulses.

- Pulse period and width can be any number of timer counts. This allows complete flexibility in the trade-off between resolution and repetition rate. All PWM outputs will occur at the same repetition rate.
- Double edge controlled PWM outputs can be programmed to be either positive going or negative going pulses.
- Match register updates are synchronized with pulse outputs to prevent generation of erroneous pulses. Software must 'release' new match values before they can become effective.
- May be used as a standard timer if the PWM mode is not enabled.
- A 32-bit Timer/Counter with a programmable 32-bit Prescaler.

### 7.23 Watchdog timer (WDT)

The purpose of the watchdog is to reset the microcontroller within a reasonable amount of time if it enters an erroneous state. When enabled, the watchdog will generate a system reset if the user program fails to 'feed' (or reload) the watchdog within a predetermined amount of time.

#### 7.23.1 Features

- Internally resets chip if not periodically reloaded.
- Debug mode.
- Enabled by software but requires a hardware reset or a watchdog reset/interrupt to be disabled.
- Incorrect/Incomplete feed sequence causes reset/interrupt if enabled.
- Flag to indicate watchdog reset.
- Programmable 32-bit timer with internal prescaler.
- Selectable time period from  $(T_{cy(WDCLK)} \times 256 \times 4)$  to  $(T_{cy(WDCLK)} \times 2^{32} \times 4)$  in multiples of  $T_{cy(WDCLK)} \times 4$ .
- The Watchdog Clock (WDCLK) source can be selected from the RTC clock, the Internal RC oscillator (IRC), or the APB peripheral clock. This gives a wide range of potential timing choices of Watchdog operation under different power reduction conditions. It also provides the ability to run the WDT from an entirely internal source that is not dependent on an external crystal and its associated components and wiring, for increased reliability.

### 7.24 RTC and battery RAM

The RTC is a set of counters for measuring time when system power is on, and optionally when power is off. It uses little power in Power-down mode. On the LPC2458, the RTC can be clocked by a separate 32.768 kHz oscillator or by a programmable prescale divider based on the APB clock. Also, the RTC is powered by its own power supply pin, VBAT, which can be connected to a battery or to the same 3.3 V supply used by the rest of the device.

The VBAT pin supplies power only to the RTC and the Battery RAM. These two functions require a minimum of power to operate, which can be supplied by an external battery. When the CPU and the rest of chip functions are stopped and power is removed, the RTC can supply an alarm output that can be used by external hardware to restore chip power and resume operation.

### 7.24.1 Features

- Measures the passage of time to maintain a calendar and clock.
- Ultra low power design to support battery powered systems.
- Provides Seconds, Minutes, Hours, Day of Month, Month, Year, Day of Week, and Day of Year.
- Dedicated 32 kHz oscillator or programmable prescaler from APB clock.
- Dedicated power supply pin can be connected to a battery or to the main 3.3 V.
- An alarm output pin is included to assist in waking up when the chip has had power removed to all functions except the RTC and Battery RAM.
- Periodic interrupts can be generated from increments of any field of the time registers, and selected fractional second values. This enhancement enables the RTC to be used as a System Timer.
- 2 kB data SRAM powered by VBAT.
- RTC and Battery RAM power supply is isolated from the rest of the chip.

## 7.25 Clocking and power control

### 7.25.1 Crystal oscillators

The LPC2458 includes three independent oscillators. These are the Main Oscillator, the Internal RC oscillator, and the RTC oscillator. Each oscillator can be used for more than one purpose as required in a particular application. Any of the three clock sources can be chosen by software to drive the PLL and ultimately the CPU.

Following reset, the LPC2458 will operate from the Internal RC oscillator until switched by software. This allows systems to operate without any external crystal and the bootloader code to operate at a known frequency.

#### 7.25.1.1 Internal RC oscillator

The IRC may be used as the clock source for the WDT, and/or as the clock that drives the PLL and subsequently the CPU. The nominal IRC frequency is 4 MHz. The IRC is trimmed to 1 % accuracy.

Upon power-up or any chip reset, the LPC2458 uses the IRC as the clock source. Software may later switch to one of the other available clock sources.

#### 7.25.1.2 Main oscillator

The main oscillator can be used as the clock source for the CPU, with or without using the PLL. The main oscillator operates at frequencies of 1 MHz to 25 MHz. This frequency can be boosted to a higher frequency, up to the maximum CPU operating frequency, by the PLL. The clock selected as the PLL input is PLLCLKIN. The ARM processor clock frequency is referred to as CCLK elsewhere in this document. The frequencies of

PLLCLKIN and CCLK are the same value unless the PLL is active and connected. The clock frequency for each peripheral can be selected individually and is referred to as PCLK. Refer to [Section 7.25.2](#) for additional information.

### 7.25.1.3 RTC oscillator

The RTC oscillator can be used as the clock source for the RTC and/or the WDT. Also, the RTC oscillator can be used to drive the PLL and the CPU.

### 7.25.2 PLL

The PLL accepts an input clock frequency in the range of 32 kHz to 25 MHz. The input frequency is multiplied up to a high frequency, then divided down to provide the actual clock used by the CPU and the USB block.

The PLL input, in the range of 32 kHz to 25 MHz, may initially be divided down by a value 'N', which may be in the range of 1 to 256. This input division provides a wide range of output frequencies from the same input frequency.

Following the PLL input divider is the PLL multiplier. This can multiply the input divider output through the use of a Current Controlled Oscillator (CCO) by a value 'M', in the range of 1 through 32768. The resulting frequency must be in the range of 275 MHz to 550 MHz. The multiplier works by dividing the CCO output by the value of M, then using a phase-frequency detector to compare the divided CCO output to the multiplier input. The error value is used to adjust the CCO frequency.

The PLL is turned off and bypassed following a chip Reset and by entering Power-down mode. PLL is enabled by software only. The program must configure and activate the PLL, wait for the PLL to lock, then connect to the PLL as a clock source.

### 7.25.3 Wake-up timer

The LPC2458 begins operation at power-up and when awakened from Power-down mode by using the 4 MHz IRC oscillator as the clock source. This allows chip operation to resume quickly. If the main oscillator or the PLL is needed by the application, software will need to enable these features and wait for them to stabilize before they are used as a clock source.

When the main oscillator is initially activated, the wake-up timer allows software to ensure that the main oscillator is fully functional before the processor uses it as a clock source and starts to execute instructions. This is important at power on, all types of Reset, and whenever any of the aforementioned functions are turned off for any reason. Since the oscillator and other functions are turned off during Power-down mode, any wake-up of the processor from Power-down mode makes use of the wake-up Timer.

The Wake-up Timer monitors the crystal oscillator to check whether it is safe to begin code execution. When power is applied to the chip, or when some event caused the chip to exit Power-down mode, some time is required for the oscillator to produce a signal of sufficient amplitude to drive the clock logic. The amount of time depends on many factors, including the rate of  $V_{DD(3V3)}$  ramp (in the case of power on), the type of crystal and its electrical characteristics (if a quartz crystal is used), as well as any other external circuitry (e.g., capacitors), and the characteristics of the oscillator itself under the existing ambient conditions.

### 7.25.4 Power control

The LPC2458 supports a variety of power control features. There are three special modes of processor power reduction: Idle mode, Sleep mode, and Power-down mode. The CPU clock rate may also be controlled as needed by changing clock sources, reconfiguring PLL values, and/or altering the CPU clock divider value. This allows a trade-off of power versus processing speed based on application requirements. In addition, Peripheral power control allows shutting down the clocks to individual on-chip peripherals, allowing fine tuning of power consumption by eliminating all dynamic power use in any peripherals that are not required for the application. Each of the peripherals has its own clock divider which provides even better power control.

The LPC2458 also implements a separate power domain in order to allow turning off power to the bulk of the device while maintaining operation of the RTC and a small SRAM, referred to as the Battery RAM.

#### 7.25.4.1 Idle mode

In Idle mode, execution of instructions is suspended until either a Reset or interrupt occurs. Peripheral functions continue operation during Idle mode and may generate interrupts to cause the processor to resume execution. Idle mode eliminates dynamic power used by the processor itself, memory systems and related controllers, and internal buses.

#### 7.25.4.2 Sleep mode

In Sleep mode, the oscillator is shut down and the chip receives no internal clocks. The processor state and registers, peripheral registers, and internal SRAM values are preserved throughout Sleep mode and the logic levels of chip pins remain static. The output of the IRC is disabled but the IRC is not powered down for a fast wake-up later. The 32 kHz RTC oscillator is not stopped because the RTC interrupts may be used as the wake-up source. The PLL is automatically turned off and disconnected. The CCLK and USB clock dividers automatically get reset to zero.

The Sleep mode can be terminated and normal operation resumed by either a Reset or certain specific interrupts that are able to function without clocks. Since all dynamic operation of the chip is suspended, Sleep mode reduces chip power consumption to a very low value. The flash memory is left on in Sleep mode, allowing a very quick wake-up.

On the wake-up from Sleep mode, if the IRC was used before entering Sleep mode, the code execution and peripherals activities will resume after 4 cycles expire. If the main external oscillator was used, the code execution will resume when 4096 cycles expire.

The customers need to reconfigure the PLL and clock dividers accordingly.

#### 7.25.4.3 Power-down mode

Power-down mode does everything that Sleep mode does, but also turns off the IRC oscillator and the flash memory. This saves more power, but requires waiting for resumption of flash operation before execution of code or data access in the flash memory can be accomplished.

On the wake-up from Power-down mode, if the IRC was used before entering Power-down mode, it will take IRC 60  $\mu$ s to start-up. After this 4 IRC cycles will expire before the code execution can then be resumed if the code was running from SRAM. In the meantime, the

flash wake-up timer then counts 4 MHz IRC clock cycles to make the 100  $\mu$ s flash start-up time. When it times out, access to the flash will be allowed. The customers need to reconfigure the PLL and clock dividers accordingly.

#### 7.25.4.4 Power domains

The LPC2458 provides two independent power domains that allow the bulk of the device to have power removed while maintaining operation of the RTC and the Battery RAM.

On the LPC2458, I/O pads are powered by the 3.3 V ( $V_{DD(3V3)}$ ) pins, while the  $V_{DD(DCDC)(3V3)}$  pins power the on-chip DC-to-DC converter which in turn provides power to the CPU and most of the peripherals.

Although both the I/O pad ring and the core require a 3.3 V supply, different powering schemes can be used depending on the actual application requirements.

The first option assumes that power consumption is not a concern and the design ties the  $V_{DD(3V3)}$  and  $V_{DD(DCDC)(3V3)}$  pins together. This approach requires only one 3.3 V power supply for both pads, the CPU, and peripherals. While this solution is simple, it does not support powering down the I/O pad ring “on the fly” while keeping the CPU and peripherals alive.

The second option uses two power supplies; a 3.3 V supply for the I/O pads ( $V_{DD(3V3)}$ ) and a dedicated 3.3 V supply for the CPU ( $V_{DD(DCDC)(3V3)}$ ). Having the on-chip DC-DC converter powered independently from the I/O pad ring enables shutting down of the I/O pad power supply “on the fly”, while the CPU and peripherals stay active.

The VBAT pin supplies power only to the RTC and the Battery RAM. These two functions require a minimum of power to operate, which can be supplied by an external battery. When the CPU and the rest of chip functions are stopped and power removed, the RTC can supply an alarm output that may be used by external hardware to restore chip power and resume operation.

## 7.26 System control

### 7.26.1 Reset

Reset has four sources on the LPC2458: the  $\overline{\text{RESET}}$  pin, the Watchdog reset, power-on reset, and the BrownOut Detection (BOD) circuit. The  $\overline{\text{RESET}}$  pin is a Schmitt trigger input pin. Assertion of chip Reset by any source, once the operating voltage attains a usable level, starts the Wake-up timer (see description in [Section 7.25.3 “Wake-up timer”](#)), causing reset to remain asserted until the external Reset is de-asserted, the oscillator is running, a fixed number of clocks have passed, and the flash controller has completed its initialization.

When the internal Reset is removed, the processor begins executing at address 0, which is initially the Reset vector mapped from the Boot Block. At that point, all of the processor and peripheral registers have been initialized to predetermined values.

### 7.26.2 Brownout detection

The LPC2458 includes 2-stage monitoring of the voltage on the  $V_{DD(3V3)}$  pins. If this voltage falls below 2.95 V, the BOD asserts an interrupt signal to the Vectored Interrupt Controller. This signal can be enabled for interrupt in the Interrupt Enable Register in the VIC in order to cause a CPU interrupt; if not, software can monitor the signal by reading a dedicated status register.

The second stage of low-voltage detection asserts Reset to inactivate the LPC2458 when the voltage on the  $V_{DD(3V3)}$  pins falls below 2.65 V. This Reset prevents alteration of the flash as operation of the various elements of the chip would otherwise become unreliable due to low voltage. The BOD circuit maintains this reset down below 1 V, at which point the power-on reset circuitry maintains the overall Reset.

Both the 2.95 V and 2.65 V thresholds include some hysteresis. In normal operation, this hysteresis allows the 2.95 V detection to reliably interrupt, or a regularly-executed event loop to sense the condition.

### 7.26.3 Code security (Code Read Protection - CRP)

This feature of the LPC2458 allows user to enable different levels of security in the system so that access to the on-chip flash and use of the JTAG and ISP can be restricted. When needed, CRP is invoked by programming a specific pattern into a dedicated flash location. IAP commands are not affected by the CRP.

There are three levels of the Code Read Protection.

CRP1 disables access to chip via the JTAG and allows partial flash update (excluding flash sector 0) using a limited set of the ISP commands. This mode is useful when CRP is required and flash field updates are needed but all sectors can not be erased.

CRP2 disables access to chip via the JTAG and only allows full flash erase and update using a reduced set of the ISP commands.

Running an application with level CRP3 selected fully disables any access to chip via the JTAG pins and the ISP. This mode effectively disables ISP override using P2[10] pin, too. It is up to the user's application to provide (if needed) flash update mechanism using IAP calls or call reinvoke ISP command to enable flash update via UART0.

#### CAUTION



If level three Code Read Protection (CRP3) is selected, no future factory testing can be performed on the device.

### 7.26.4 AHB

The LPC2458 implements two AHB in order to allow the Ethernet block to operate without interference caused by other system activity. The primary AHB, referred to as AHB1, includes the Vectored Interrupt Controller, GPDMA controller, USB interface, and 16 kB SRAM.



The second AHB, referred to as AHB2, includes only the Ethernet block and an associated 16 kB SRAM. In addition, a bus bridge is provided that allows the secondary AHB to be a bus master on AHB1, allowing expansion of Ethernet buffer space into off-chip memory or unused space in memory residing on AHB1.

In summary, bus masters with access to AHB1 are the ARM7 itself, the USB block, the GPDMA function, and the Ethernet block (via the bus bridge from AHB2). Bus masters with access to AHB2 are the ARM7 and the Ethernet block.

### 7.26.5 External interrupt inputs

The LPC2458 includes up to 68 edge sensitive interrupt inputs combined with up to four level sensitive external interrupt inputs as selectable pin functions. The external interrupt inputs can optionally be used to wake up the processor from Power-down mode.

### 7.26.6 Memory mapping control

The memory mapping control alters the mapping of the interrupt vectors that appear at the beginning at address 0x0000 0000. Vectors may be mapped to the bottom of the Boot ROM, the SRAM, or external memory. This allows code running in different memory spaces to have control of the interrupts.

## 7.27 Emulation and debugging

The LPC2458 support emulation and debugging via a JTAG serial port. A trace port allows tracing program execution. Debugging and trace functions are multiplexed only with GPIOs on P2[0] to P2[9]. This means that all communication, timer, and interface peripherals residing on other pins are available during the development and debugging phase as they are when the application is run in the embedded system itself.

### 7.27.1 EmbeddedICE

The EmbeddedICE logic provides on-chip debug support. The debugging of the target system requires a host computer running the debugger software and an EmbeddedICE protocol convertor. The EmbeddedICE protocol convertor converts the Remote Debug Protocol commands to the JTAG data needed to access the ARM7TDMI-S core present on the target system.

The ARM core has a Debug Communication Channel (DCC) function built-in. The DCC allows a program running on the target to communicate with the host debugger or another separate host without stopping the program flow or even entering the debug state. The DCC is accessed as a coprocessor 14 by the program running on the ARM7TDMI-S core. The DCC allows the JTAG port to be used for sending and receiving data without affecting the normal program flow. The DCC data and control registers are mapped in to addresses in the EmbeddedICE logic.

The JTAG clock (TCK) must be slower than  $\frac{1}{6}$  of the CPU clock (CCLK) for the JTAG interface to operate.

### 7.27.2 Embedded trace

Since the LPC2458 have significant amounts of on-chip memories, it is not possible to determine how the processor core is operating simply by observing the external pins. The ETM provides real-time trace capability for deeply embedded processor cores. It outputs

information about processor execution to a trace port. A software debugger allows configuration of the ETM using a JTAG interface and displays the trace information that has been captured.

The ETM is connected directly to the ARM core and not to the main AMBA system bus. It compresses the trace information and exports it through a narrow trace port. An external Trace Port Analyzer captures the trace information under software debugger control. The trace port can broadcast the Instruction trace information. Instruction trace (or PC trace) shows the flow of execution of the processor and provides a list of all the instructions that were executed. Instruction trace is significantly compressed by only broadcasting branch addresses as well as a set of status signals that indicate the pipeline status on a cycle by cycle basis. Trace information generation can be controlled by selecting the trigger resource. Trigger resources include address comparators, counters and sequencers. Since trace information is compressed the software debugger requires a static image of the code being executed. Self-modifying code can not be traced because of this restriction.

### 7.27.3 RealMonitor

RealMonitor is a configurable software module, developed by ARM Inc., which enables real-time debug. It is a lightweight debug monitor that runs in the background while users debug their foreground application. It communicates with the host using the DCC, which is present in the EmbeddedICE logic. The LPC2458 contain a specific configuration of RealMonitor software programmed into the on-chip ROM memory.

## 8. Limiting values

**Table 6. Limiting values**

In accordance with the Absolute Maximum Rating System (IEC 60134).<sup>[1]</sup>

| Symbol              | Parameter                                 | Conditions                                                                         | Min                    | Max                 | Unit |
|---------------------|-------------------------------------------|------------------------------------------------------------------------------------|------------------------|---------------------|------|
| $V_{DD(3V3)}$       | supply voltage (3.3 V)                    | core and external rail                                                             | 3.0                    | 3.6                 | V    |
| $V_{DD(DCDC)(3V3)}$ | DC-to-DC converter supply voltage (3.3 V) |                                                                                    | 3.0                    | 3.6                 | V    |
| $V_{DDA}$           | analog 3.3 V pad supply voltage           |                                                                                    | -0.5                   | +4.6                | V    |
| $V_{i(VBAT)}$       | input voltage on pin VBAT                 | for the RTC                                                                        | -0.5                   | +4.6                | V    |
| $V_{i(VREF)}$       | input voltage on pin VREF                 |                                                                                    | -0.5                   | +4.6                | V    |
| $V_{IA}$            | analog input voltage                      | on ADC related pins                                                                | -0.5                   | +5.1                | V    |
| $V_I$               | input voltage                             | 5 V tolerant I/O pins; only valid when the $V_{DD(3V3)}$ supply voltage is present | <sup>[2]</sup> -0.5    | +6.0                | V    |
|                     |                                           | other I/O pins                                                                     | <sup>[2][3]</sup> -0.5 | $V_{DD(3V3)} + 0.5$ | V    |
| $I_{DD}$            | supply current                            | per supply pin                                                                     | <sup>[4]</sup> -       | 100                 | mA   |
| $I_{SS}$            | ground current                            | per ground pin                                                                     | <sup>[4]</sup> -       | 100                 | mA   |
| $T_{stg}$           | storage temperature                       |                                                                                    | <sup>[5]</sup> -65     | +150                | °C   |
| $P_{tot(pack)}$     | total power dissipation (per package)     | based on package heat transfer, not device power consumption                       | -                      | 1.5                 | W    |
| $V_{esd}$           | electrostatic discharge voltage           | human body model; all pins                                                         | <sup>[6]</sup> -2000   | +2000               | V    |

[1] The following applies to the limiting values:

- a) This product includes circuitry specifically designed for the protection of its internal devices from the damaging effects of excessive static charge. Nonetheless, it is suggested that conventional precautions be taken to avoid applying greater than the rated maximum.
- b) Parameters are valid over operating temperature range unless otherwise specified. All voltages are with respect to  $V_{SSIO}/V_{SSCORE}$  unless otherwise noted.

[2] Including voltage on outputs in 3-state mode.

[3] Not to exceed 4.6 V.

[4] The peak current is limited to 25 times the corresponding maximum current.

[5] Dependent on package type.

[6] Human body model: equivalent to discharging a 100 pF capacitor through a 1.5 kΩ series resistor.

## 9. Static characteristics

**Table 7. Static characteristics**
 $T_{amb} = -40\text{ }^{\circ}\text{C}$  to  $+85\text{ }^{\circ}\text{C}$  for commercial applications, unless otherwise specified.

| Symbol                                 | Parameter                                 | Conditions                                                                         | Min                                | Typ <sup>[1]</sup> | Max           | Unit          |
|----------------------------------------|-------------------------------------------|------------------------------------------------------------------------------------|------------------------------------|--------------------|---------------|---------------|
| $V_{DD(3V3)}$                          | supply voltage (3.3 V)                    | core and external rail                                                             | 3.0                                | 3.3                | 3.6           | V             |
| $V_{DD(DCDC)(3V3)}$                    | DC-to-DC converter supply voltage (3.3 V) |                                                                                    | 3.0                                | 3.3                | 3.6           | V             |
| $V_{DDA}$                              | analog 3.3 V pad supply voltage           |                                                                                    | 3.0                                | 3.3                | 3.6           | V             |
| $V_{I(VBAT)}$                          | input voltage on pin VBAT                 |                                                                                    | <sup>[2]</sup> 2.0                 | 3.3                | 3.6           | V             |
| $V_{I(VREF)}$                          | input voltage on pin VREF                 |                                                                                    | 2.5                                | 3.3                | $V_{DDA}$     | V             |
| <b>Standard port pins, RESET, RTCK</b> |                                           |                                                                                    |                                    |                    |               |               |
| $I_{IL}$                               | LOW-level input current                   | $V_I = 0\text{ V}$ ; no pull-up                                                    | -                                  | -                  | 3             | $\mu\text{A}$ |
| $I_{IH}$                               | HIGH-level input current                  | $V_I = V_{DD(3V3)}$ ; no pull-down                                                 | -                                  | -                  | 3             | $\mu\text{A}$ |
| $I_{OZ}$                               | OFF-state output current                  | $V_O = 0\text{ V}$ ; $V_O = V_{DD(3V3)}$ ; no pull-up/down                         | -                                  | -                  | 3             | $\mu\text{A}$ |
| $I_{latch}$                            | I/O latch-up current                      | $-(0.5V_{DD(3V3)}) < V_I < (1.5V_{DD(3V3)})$ ; $T_j < 125\text{ }^{\circ}\text{C}$ | -                                  | -                  | 100           | mA            |
| $V_I$                                  | input voltage                             | pin configured to provide a digital function                                       | <sup>[3][4][5][6]</sup> 0          | -                  | 5.5           | V             |
| $V_O$                                  | output voltage                            | output active                                                                      | 0                                  | -                  | $V_{DD(3V3)}$ | V             |
| $V_{IH}$                               | HIGH-level input voltage                  |                                                                                    | 2.0                                | -                  | -             | V             |
| $V_{IL}$                               | LOW-level input voltage                   |                                                                                    | -                                  | -                  | 0.8           | V             |
| $V_{hys}$                              | hysteresis voltage                        |                                                                                    | 0.4                                | -                  | -             | V             |
| $V_{OH}$                               | HIGH-level output voltage                 | $I_{OH} = -4\text{ mA}$                                                            | <sup>[7]</sup> $V_{DD(3V3)} - 0.4$ | -                  | -             | V             |
| $V_{OL}$                               | LOW-level output voltage                  | $I_{OL} = -4\text{ mA}$                                                            | <sup>[7]</sup> -                   | -                  | 0.4           | V             |
| $I_{OH}$                               | HIGH-level output current                 | $V_{OH} = V_{DD(3V3)} - 0.4\text{ V}$                                              | <sup>[7]</sup> -4                  | -                  | -             | mA            |
| $I_{OL}$                               | LOW-level output current                  | $V_{OL} = 0.4\text{ V}$                                                            | <sup>[7]</sup> 4                   | -                  | -             | mA            |
| $I_{OHS}$                              | HIGH-level short-circuit output current   | $V_{OH} = 0\text{ V}$                                                              | <sup>[8]</sup> -                   | -                  | -45           | mA            |
| $I_{OLS}$                              | LOW-level short-circuit output current    | $V_{OL} = V_{DDA}$                                                                 | <sup>[8]</sup> -                   | -                  | 50            | mA            |
| $I_{pd}$                               | pull-down current                         | $V_I = 5\text{ V}$                                                                 | <sup>[9]</sup> 10                  | 50                 | 150           | $\mu\text{A}$ |
| $I_{pu}$                               | pull-up current                           | $V_I = 0\text{ V}$                                                                 | -15                                | -50                | -85           | $\mu\text{A}$ |
|                                        |                                           | $V_{DD(3V3)} < V_I < 5\text{ V}$                                                   | <sup>[9]</sup> 0                   | 0                  | 0             | $\mu\text{A}$ |

**Table 7. Static characteristics ...continued**

$T_{amb} = -40\text{ }^{\circ}\text{C}$  to  $+85\text{ }^{\circ}\text{C}$  for commercial applications, unless otherwise specified.

| Symbol                                             | Parameter                                                 | Conditions                                                                                          | Min              | Typ <sup>[1]</sup> | Max              | Unit          |
|----------------------------------------------------|-----------------------------------------------------------|-----------------------------------------------------------------------------------------------------|------------------|--------------------|------------------|---------------|
| $I_{DD(DCDC)act(3V3)}$                             | active mode DC-to-DC converter supply current (3.3 V)     | $V_{DD(DCDC)(3V3)} = 3.3\text{ V}$ ;<br>$T_{amb} = 25\text{ }^{\circ}\text{C}$ ; code<br>while(1){} |                  |                    |                  |               |
|                                                    |                                                           | executed from flash; no peripherals enabled;<br>PCLK = CCLK                                         |                  |                    |                  |               |
|                                                    |                                                           | CCLK = 10 MHz                                                                                       | -                | 15                 | -                | mA            |
|                                                    |                                                           | CCLK = 72 MHz                                                                                       | -                | 63                 | -                | mA            |
|                                                    |                                                           | all peripherals enabled;<br>PCLK = CCLK / 8                                                         |                  |                    |                  |               |
|                                                    |                                                           | CCLK = 10 MHz                                                                                       | -                | 21                 | -                | mA            |
|                                                    |                                                           | CCLK = 72 MHz                                                                                       | -                | 92                 | -                | mA            |
| $I_{DD(DCDC)pd(3V3)}$                              | power-down mode DC-to-DC converter supply current (3.3 V) | $V_{DD(DCDC)(3V3)} = 3.3\text{ V}$ ;<br>$T_{amb} = 25\text{ }^{\circ}\text{C}$                      | -                | 150                | -                | $\mu\text{A}$ |
|                                                    |                                                           |                                                                                                     |                  |                    |                  |               |
| $I_{BATact}$                                       | active mode battery supply current                        | DC-to-DC converter on                                                                               | [10]             | -                  | 20               | $\mu\text{A}$ |
|                                                    |                                                           | DC-to-DC converter off                                                                              | [10]             | -                  | 28               | $\mu\text{A}$ |
| <b>I<sup>2</sup>C-bus pins (P0[27] and P0[28])</b> |                                                           |                                                                                                     |                  |                    |                  |               |
| $V_{IH}$                                           | HIGH-level input voltage                                  |                                                                                                     | $0.7V_{DD(3V3)}$ | -                  | -                | V             |
| $V_{IL}$                                           | LOW-level input voltage                                   |                                                                                                     | -                | -                  | $0.3V_{DD(3V3)}$ | V             |
| $V_{hys}$                                          | hysteresis voltage                                        |                                                                                                     | -                | $0.5V_{DD(3V3)}$   | -                | V             |
| $V_{OL}$                                           | LOW-level output voltage                                  | $I_{OLS} = 3\text{ mA}$                                                                             | [7]              | -                  | 0.4              | V             |
| $I_{LI}$                                           | input leakage current                                     | $V_I = V_{DD(3V3)}$                                                                                 | [11]             | -                  | 2                | $\mu\text{A}$ |
|                                                    |                                                           | $V_I = 5\text{ V}$                                                                                  | -                | 10                 | 22               | $\mu\text{A}$ |
| <b>Oscillator pins</b>                             |                                                           |                                                                                                     |                  |                    |                  |               |
| $V_{i(XTAL1)}$                                     | input voltage on pin XTAL1                                |                                                                                                     | 0                | -                  | 1.8              | V             |
| $V_{o(XTAL2)}$                                     | output voltage on pin XTAL2                               |                                                                                                     | 0                | -                  | 1.8              | V             |
| $V_{i(RTCX1)}$                                     | input voltage on pin RTCX1                                |                                                                                                     | 0                | -                  | 1.8              | V             |
| $V_{o(RTCX2)}$                                     | output voltage on pin RTCX2                               |                                                                                                     | 0                | -                  | 1.8              | V             |
| <b>USB pins</b>                                    |                                                           |                                                                                                     |                  |                    |                  |               |
| $I_{OZ}$                                           | OFF-state output current                                  | $0\text{ V} < V_I < 3.3\text{ V}$                                                                   | -                | -                  | $\pm 10$         | $\mu\text{A}$ |
| $V_{BUS}$                                          | bus supply voltage                                        |                                                                                                     | -                | -                  | 5.25             | V             |

**Table 7. Static characteristics ...continued** $T_{amb} = -40\text{ }^{\circ}\text{C}$  to  $+85\text{ }^{\circ}\text{C}$  for commercial applications, unless otherwise specified.

| Symbol         | Parameter                                                          | Conditions                                           | Min     | Typ <sup>[1]</sup> | Max  | Unit       |
|----------------|--------------------------------------------------------------------|------------------------------------------------------|---------|--------------------|------|------------|
| $V_{DI}$       | differential input sensitivity                                     | $ (D+) - (D-) $                                      | 0.2     | -                  | -    | V          |
| $V_{CM}$       | differential common mode voltage range                             | includes $V_{DI}$ range                              | 0.8     | -                  | 2.5  | V          |
| $V_{th(rs)se}$ | single-ended receiver switching threshold voltage                  |                                                      | 0.8     | -                  | 2.0  | V          |
| $V_{OL}$       | LOW-level output voltage for low-/full-speed                       | $R_L$ of 1.5 k $\Omega$ to 3.6 V                     | -       | -                  | 0.18 | V          |
| $V_{OH}$       | HIGH-level output voltage (driven) for low-/full-speed             | $R_L$ of 15 k $\Omega$ to GND                        | 2.8     | -                  | 3.5  | V          |
| $C_{trans}$    | transceiver capacitance                                            | pin to GND                                           | -       | -                  | 20   | pF         |
| $Z_{DRV}$      | driver output impedance for driver which is not high-speed capable | with 33 $\Omega$ series resistor; steady state drive | [12] 36 | -                  | 44.1 | $\Omega$   |
| $R_{pu}$       | pull-up resistance                                                 | SoftConnect = ON                                     | 1.1     | -                  | 1.9  | k $\Omega$ |

[1] Typical ratings are not guaranteed. The values listed are at room temperature (25  $^{\circ}\text{C}$ ), nominal supply voltages

[2] The RTC typically fails when  $V_{i(VBAT)}$  drops below 1.6 V.

[3] Including voltage on outputs in 3-state mode.

[4]  $V_{DD(3V3)}$  supply voltages must be present.

[5] 3-state outputs go into 3-state mode when  $V_{DD(3V3)}$  is grounded.

[6] Please also see the errata note mentioned in errata sheet.

[7] Accounts for 100 mV voltage drop in all supply lines.

[8] Allowed as long as the current limit does not exceed the maximum current allowed by the device.

[9] Minimum condition for  $V_I = 4.5\text{ V}$ , maximum condition for  $V_I = 5.5\text{ V}$ .

[10] On pin VBAT.

[11] To  $V_{SSIO}$ .

[12] Includes external resistors of  $18\text{ }\Omega \pm 1\%$  on D+ and D-.

**Table 8. ADC static characteristics**

$V_{DDA} = 2.5\text{ V to }3.6\text{ V}$ ;  $T_{amb} = -40\text{ }^{\circ}\text{C to }+85\text{ }^{\circ}\text{C}$  unless otherwise specified; ADC frequency 4.5 MHz.

| Symbol       | Parameter                           | Conditions | Min       | Typ | Max       | Unit       |
|--------------|-------------------------------------|------------|-----------|-----|-----------|------------|
| $V_{IA}$     | analog input voltage                |            | 0         | -   | $V_{DDA}$ | V          |
| $C_{ia}$     | analog input capacitance            |            | -         | -   | 1         | pF         |
| $E_D$        | differential linearity error        |            | [1][2][3] | -   | $\pm 1$   | LSB        |
| $E_{L(adj)}$ | integral non-linearity              |            | [1][4]    | -   | $\pm 2$   | LSB        |
| $E_O$        | offset error                        |            | [1][5]    | -   | $\pm 3$   | LSB        |
| $E_G$        | gain error                          |            | [1][6]    | -   | $\pm 0.5$ | %          |
| $E_T$        | absolute error                      |            | [1][7]    | -   | $\pm 4$   | LSB        |
| $R_{vsi}$    | voltage source interface resistance |            | [8]       | -   | 40        | k $\Omega$ |

[1] Conditions:  $V_{SSA} = 0\text{ V}$ ,  $V_{DDA} = 3.3\text{ V}$ .

[2] The ADC is monotonic, there are no missing codes.

[3] The differential linearity error ( $E_D$ ) is the difference between the actual step width and the ideal step width. See [Figure 4](#).

[4] The integral non-linearity ( $E_{L(adj)}$ ) is the peak difference between the center of the steps of the actual and the ideal transfer curve after appropriate adjustment of gain and offset errors. See [Figure 4](#).

[5] The offset error ( $E_O$ ) is the absolute difference between the straight line which fits the actual curve and the straight line which fits the ideal curve. See [Figure 4](#).

[6] The gain error ( $E_G$ ) is the relative difference in percent between the straight line fitting the actual transfer curve after removing offset error, and the straight line which fits the ideal transfer curve. See [Figure 4](#).

[7] The absolute error ( $E_T$ ) is the maximum difference between the center of the steps of the actual transfer curve of the non-calibrated ADC and the ideal transfer curve. See [Figure 4](#).

[8] See [Figure 5](#).

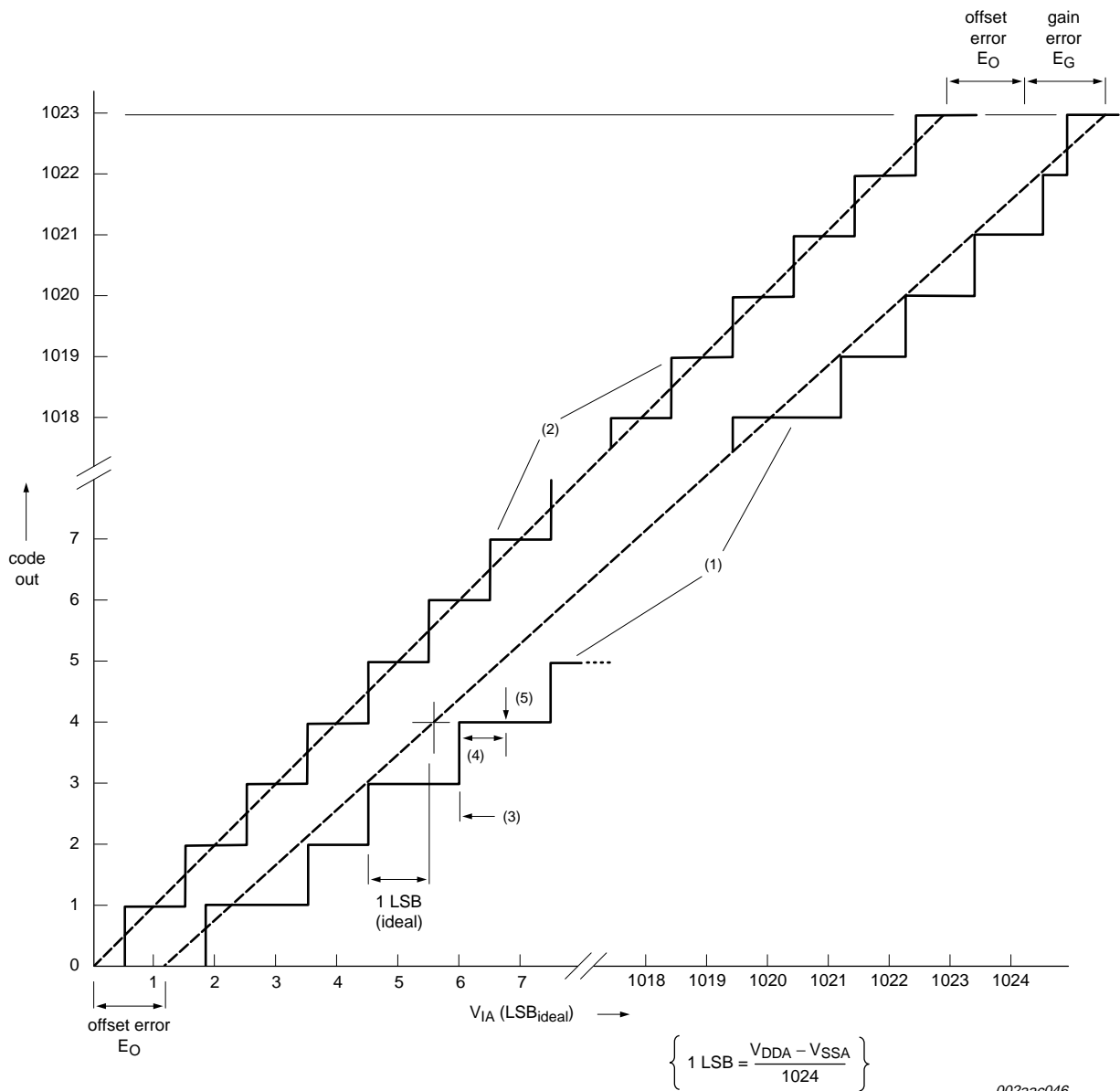

002aac046

- (1) Example of an actual transfer curve.
- (2) The ideal transfer curve.
- (3) Differential linearity error (E<sub>D</sub>).
- (4) Integral non-linearity (E<sub>L(adj)</sub>).
- (5) Center of a step of the actual transfer curve.

Fig 4. ADC characteristics



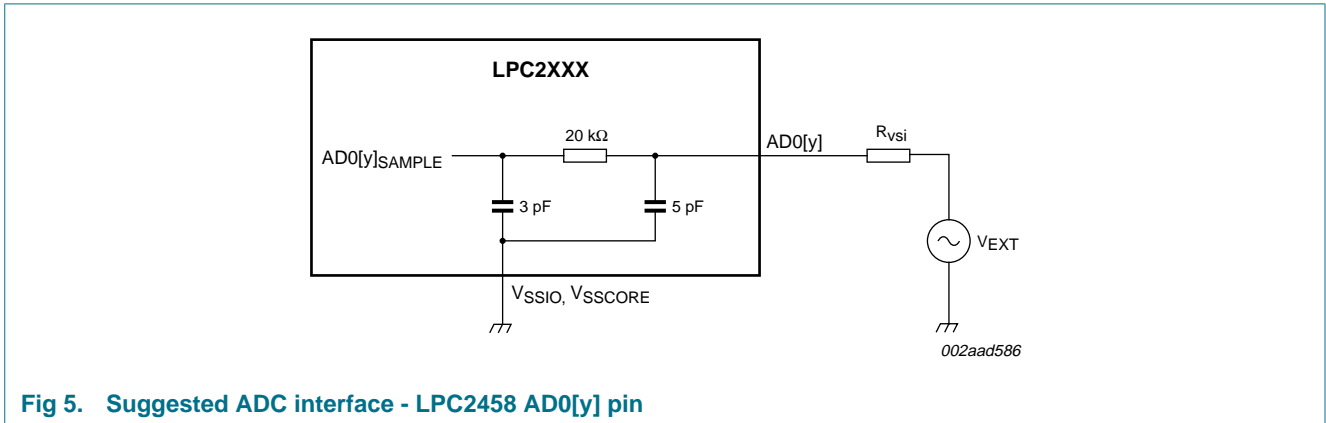

Fig 5. Suggested ADC interface - LPC2458 AD0[y] pin

## 10. Dynamic characteristics

**Table 9. Dynamic characteristics of USB pins (full-speed)**

$C_L = 50 \text{ pF}$ ;  $R_{pu} = 1.5 \text{ k}\Omega$  on D+ to  $V_{DD(3V3)}$ , unless otherwise specified.

| Symbol      | Parameter                                                   | Conditions                                       | Min    | Typ | Max   | Unit |
|-------------|-------------------------------------------------------------|--------------------------------------------------|--------|-----|-------|------|
| $t_r$       | rise time                                                   | 10 % to 90 %                                     | 8.5    | -   | 13.8  | ns   |
| $t_f$       | fall time                                                   | 10 % to 90 %                                     | 7.7    | -   | 13.7  | ns   |
| $t_{FRFM}$  | differential rise and fall time matching                    | $t_r / t_f$                                      | -      | -   | 109   | %    |
| $V_{CRS}$   | output signal crossover voltage                             |                                                  | 1.3    | -   | 2.0   | V    |
| $t_{FEOPT}$ | source SE0 interval of EOP                                  | see <a href="#">Figure 7</a>                     | 160    | -   | 175   | ns   |
| $t_{FDEOP}$ | source jitter for differential transition to SE0 transition | see <a href="#">Figure 7</a>                     | -2     | -   | +5    | ns   |
| $t_{JR1}$   | receiver jitter to next transition                          |                                                  | -18.5  | -   | +18.5 | ns   |
| $t_{JR2}$   | receiver jitter for paired transitions                      | 10 % to 90 %                                     | -9     | -   | +9    | ns   |
| $t_{EOPR1}$ | EOP width at receiver                                       | must reject as EOP; see <a href="#">Figure 7</a> | [1] 40 | -   | -     | ns   |
| $t_{EOPR2}$ | EOP width at receiver                                       | must accept as EOP; see <a href="#">Figure 7</a> | [1] 82 | -   | -     | ns   |

[1] Characterized but not implemented as production test. Guaranteed by design.

**Table 10. Dynamic characteristics**

$T_{amb} = -40 \text{ }^\circ\text{C}$  to  $+85 \text{ }^\circ\text{C}$  for commercial applications;  $V_{DD(3V3)}$  over specified ranges.[1]

| Symbol                                             | Parameter            | Conditions                                                                                        | Min                       | Typ[2] | Max  | Unit |
|----------------------------------------------------|----------------------|---------------------------------------------------------------------------------------------------|---------------------------|--------|------|------|
| <b>External clock</b>                              |                      |                                                                                                   |                           |        |      |      |
| $f_{osc}$                                          | oscillator frequency |                                                                                                   | 1                         | -      | 25   | MHz  |
| $T_{cy(clk)}$                                      | clock cycle time     |                                                                                                   | 42                        | -      | 1000 | ns   |
| $t_{CHCX}$                                         | clock HIGH time      |                                                                                                   | $T_{cy(clk)} \times 0.4$  | -      | -    | ns   |
| $t_{CLCX}$                                         | clock LOW time       |                                                                                                   | $T_{cy(clk)} \times 0.4$  | -      | -    | ns   |
| $t_{CLCH}$                                         | clock rise time      |                                                                                                   | -                         | -      | 5    | ns   |
| $t_{CHCL}$                                         | clock fall time      |                                                                                                   | -                         | -      | 5    | ns   |
| <b>I<sup>2</sup>C-bus pins (P0[27] and P0[28])</b> |                      |                                                                                                   |                           |        |      |      |
| $t_{f(o)}$                                         | output fall time     | $V_{IH}$ to $V_{IL}$                                                                              | $20 + 0.1 \times C_b$ [3] | -      | -    | ns   |
| <b>SSP interface</b>                               |                      |                                                                                                   |                           |        |      |      |
| $t_{su(SPI\_MISO)}$                                | SPI_MISO set-up time | $T_{amb} = 25 \text{ }^\circ\text{C}$ ; measured in SPI Master mode; see <a href="#">Figure 8</a> | -                         | 11     | -    | ns   |

[1] Parameters are valid over operating temperature range unless otherwise specified.

[2] Typical ratings are not guaranteed. The values listed are at room temperature (25 °C), nominal supply voltages.

[3] Bus capacitance  $C_b$  in pF, from 10 pF to 400 pF.

**Table 11. Dynamic characteristics: Static external memory interface**  
 $C_L = 30 \text{ pF}$ ,  $T_{amb} = -40^\circ\text{C to } 85^\circ\text{C}$ ,  $V_{DD(DCDC)(3V3)} = V_{DD(3V3)} = 3.0 \text{ V to } 3.6 \text{ V}$ ,  $AHB \text{ clock} = 1 \text{ MHz}$

| Symbol                                               | Parameter                                          | Conditions | Min                                                                   | Typ                                                 | Max                                                  | Unit |
|------------------------------------------------------|----------------------------------------------------|------------|-----------------------------------------------------------------------|-----------------------------------------------------|------------------------------------------------------|------|
| <b>Common to read and write cycles<sup>[1]</sup></b> |                                                    |            |                                                                       |                                                     |                                                      |      |
| $t_{CSLAV}$                                          | $\overline{CS}$ LOW to address valid time          |            | -0.29                                                                 | 0.20                                                | 2.54                                                 | ns   |
| <b>Read cycle parameters<sup>[1][2]</sup></b>        |                                                    |            |                                                                       |                                                     |                                                      |      |
| $t_{OELAV}$                                          | $\overline{OE}$ LOW to address valid time          |            | -0.29                                                                 | 0.20                                                | 2.54                                                 | ns   |
| $t_{CSLOEL}$                                         | $\overline{CS}$ LOW to $\overline{OE}$ LOW time    |            | $-0.78 + T_{cy(CCLK)} \times WAITOEN$                                 | $0 + T_{cy(CCLK)} \times WAITOEN$                   | $0.49 + T_{cy(CCLK)} \times WAITOEN$                 | ns   |
| $t_{am}$                                             | memory access time                                 |            | <sup>[3][4]</sup> $(WAITRD - WAITOEN + 1) \times T_{cy(CCLK)} - 8.11$ | $(WAITRD - WAITOEN + 1) \times T_{cy(CCLK)} - 9.57$ | $(WAITRD - WAITOEN + 1) \times T_{cy(CCLK)} - 12.70$ | ns   |
| $t_{h(D)}$                                           | data input hold time                               |            | <sup>[5]</sup> 1.29                                                   | 4.22                                                | 5.20                                                 | ns   |
| $t_{CSHOEH}$                                         | $\overline{CS}$ HIGH to $\overline{OE}$ HIGH time  |            | -0.49                                                                 | 0                                                   | 0.20                                                 | ns   |
| $t_{OEHAVN}$                                         | $\overline{OE}$ HIGH to address invalid time       |            | -0.20                                                                 | 0.20                                                | 2.44                                                 | ns   |
| $t_{OELOEH}$                                         | $\overline{OE}$ LOW to $\overline{OE}$ HIGH time   |            | $-0.59 + (WAITRD - WAITOEN + 1) \times T_{cy(CCLK)}$                  | $0 + (WAITRD - WAITOEN + 1) \times T_{cy(CCLK)}$    | $0.10 + (WAITRD - WAITOEN + 1) \times T_{cy(CCLK)}$  | ns   |
| $t_{BLSLAV}$                                         | $\overline{BLS}$ LOW to address valid time         |            | -0.39                                                                 | 0                                                   | 2.54                                                 | ns   |
| $t_{CSHBLSH}$                                        | $\overline{CS}$ HIGH to $\overline{BLS}$ HIGH time |            | -0.88                                                                 | 0.49                                                | 0.68                                                 | ns   |
| <b>Write cycle parameters<sup>[1][6]</sup></b>       |                                                    |            |                                                                       |                                                     |                                                      |      |
| $t_{CSLWEL}$                                         | $\overline{CS}$ LOW to $\overline{WE}$ LOW time    |            | $-0.88 + T_{cy(CCLK)} \times (1 + WAITWEN)$                           | $0.10 + T_{cy(CCLK)} \times (1 + WAITWEN)$          | $0.20 + T_{cy(CCLK)} \times (1 + WAITWEN)$           | ns   |
| $t_{CSLBLSL}$                                        | $\overline{CS}$ LOW to $\overline{BLS}$ LOW time   |            | -0.88                                                                 | 0.49                                                | 0.98                                                 | ns   |
| $t_{WELDV}$                                          | $\overline{WE}$ LOW to data valid time             |            | 0.68                                                                  | 2.54                                                | 5.86                                                 | ns   |
| $t_{CSLDV}$                                          | $\overline{CS}$ LOW to data valid time             |            | 0                                                                     | 2.64                                                | 4.79                                                 | ns   |
| $t_{WELWEH}$                                         | $\overline{WE}$ LOW to $\overline{WE}$ HIGH time   |            | <sup>[3]</sup> $-0.78 + T_{cy(CCLK)} \times (WAITWR - WAITWEN + 1)$   | $0 + T_{cy(CCLK)} \times (WAITWR - WAITWEN + 1)$    | $0.10 + T_{cy(CCLK)} \times (WAITWR - WAITWEN + 1)$  | ns   |
| $t_{BLSLBLSH}$                                       | $\overline{BLS}$ LOW to $\overline{BLS}$ HIGH time |            | <sup>[3]</sup> $-0.88 + T_{cy(CCLK)} \times (WAITWR - WAITWEN + 3)$   | $0 + T_{cy(CCLK)} \times (WAITWR - WAITWEN + 3)$    | $0.59 + T_{cy(CCLK)} \times (WAITWR - WAITWEN + 3)$  | ns   |
| $t_{WEHAVN}$                                         | $\overline{WE}$ HIGH to address invalid time       |            | <sup>[3]</sup> $0 + T_{cy(CCLK)}$                                     | $0.20 + T_{cy(CCLK)}$                               | $2.74 + T_{cy(CCLK)}$                                | ns   |

**Table 11. Dynamic characteristics: Static external memory interface ...continued**
 $C_L = 30 \text{ pF}$ ,  $T_{amb} = -40^\circ\text{C to } 85^\circ\text{C}$ ,  $V_{DD(DCDC)}(3V3) = V_{DD(3V3)} = 3.0 \text{ V to } 3.6 \text{ V}$ ,  $AHB \text{ clock} = 1 \text{ MHz}$ 

| Symbol        | Parameter                                     | Conditions | Min       | Typ  | Max  | Unit |
|---------------|-----------------------------------------------|------------|-----------|------|------|------|
| $t_{WEHDNV}$  | $\overline{WE}$ HIGH to data invalid time     |            | [3] 0.78  | 2.54 | 5.96 | ns   |
| $t_{BLSHANV}$ | $\overline{BLS}$ HIGH to address invalid time |            | [3] -0.29 | 0.20 | 2.54 | ns   |
| $t_{BLSHDNV}$ | $\overline{BLS}$ HIGH to data invalid time    |            | [3] 0     | 2.54 | 5.37 | ns   |

[1]  $V_{OH} = 2.5 \text{ V}$ ,  $V_{OL} = 0.2 \text{ V}$ .

[2]  $V_{IH} = 2.5 \text{ V}$ ,  $V_{IL} = 0.5 \text{ V}$ .

[3]  $T_{cy(CCLK)} = 1/CCLK$ .

[4] Latest of address valid,  $\overline{CS}$  LOW,  $\overline{OE}$  LOW to data valid.

[5] Earliest of  $\overline{CS}$  HIGH,  $\overline{OE}$  HIGH, address change to data invalid.

[6] Byte lane state bit (PB) = 1.

**Table 12. Dynamic characteristics: Dynamic external memory interface** $C_L = 30\text{ pF}$ ,  $T_{amb} = -40\text{ }^\circ\text{C}$  to  $85\text{ }^\circ\text{C}$ ,  $V_{DD(DCDC)(3V3)} = V_{DD(3V3)} = 3.0\text{ V}$  to  $3.6\text{ V}$ , AHB clock = 1 MHz

| Symbol                        | Parameter                              | Conditions | Min  | Typ  | Max  | Unit |
|-------------------------------|----------------------------------------|------------|------|------|------|------|
| <b>Common</b>                 |                                        |            |      |      |      |      |
| $t_{d(SV)}$                   | chip select valid delay time           |            | -    | 1.05 | 1.76 | ns   |
| $t_{h(S)}$                    | chip select hold time                  |            | 0.1  | 1.02 | -    | ns   |
| $t_{d(RASV)}$                 | row address strobe valid delay time    |            | -    | 1.51 | 1.95 | ns   |
| $t_{h(RAS)}$                  | row address strobe hold time           |            | 0.5  | 1.51 | -    | ns   |
| $t_{d(CASV)}$                 | column address strobe valid delay time |            | -    | 0.98 | 1.27 | ns   |
| $t_{h(CAS)}$                  | column address strobe hold time        |            | 0.1  | 0.97 | -    | ns   |
| $t_{d(WV)}$                   | write valid delay time                 |            | -    | 0.84 | 1.95 | ns   |
| $t_{h(W)}$                    | write hold time                        |            | 0.1  | 0.84 | -    | ns   |
| $t_{d(GV)}$                   | output enable valid delay time         |            | -    | 0.95 | 1.86 | ns   |
| $t_{h(G)}$                    | output enable hold time                |            | 0.1  | 1    | -    | ns   |
| $t_{d(AV)}$                   | address valid delay time               |            | -    | 0.87 | 1.95 | ns   |
| $t_{h(A)}$                    | address hold time                      |            | 0.1  | 0.81 | -    | ns   |
| <b>Read cycle parameters</b>  |                                        |            |      |      |      |      |
| $t_{su(D)}$                   | data input set-up time                 |            | 0.51 | 2.24 | -    | ns   |
| $t_{h(D)}$                    | data input hold time                   |            | 0.57 | 2.41 | -    | ns   |
| <b>Write cycle parameters</b> |                                        |            |      |      |      |      |
| $t_{d(QV)}$                   | data output valid delay time           |            | -    | 2.65 | 4.36 | ns   |
| $t_{h(Q)}$                    | data output hold time                  |            | 0.49 | 2.61 | -    | ns   |

10.1 Timing

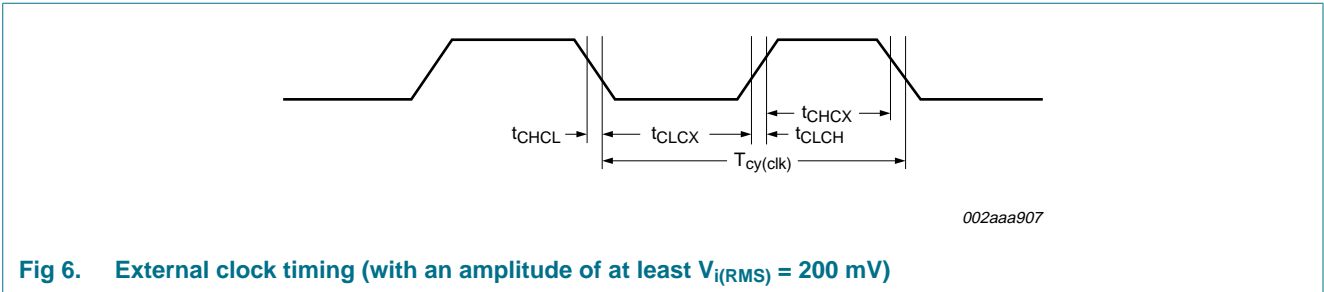

Fig 6. External clock timing (with an amplitude of at least  $V_{i(RMS)} = 200\text{ mV}$ )

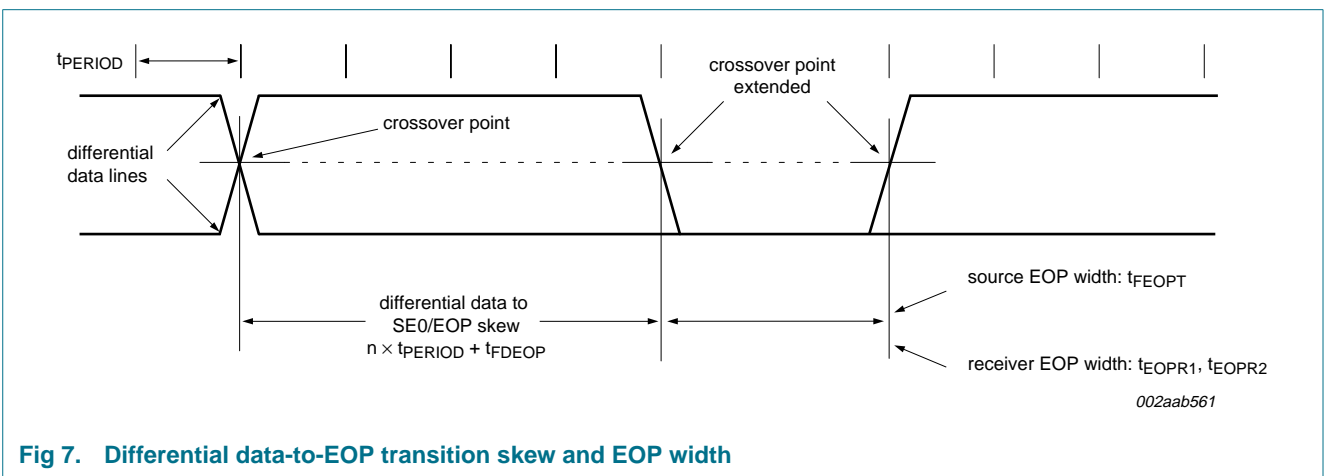

Fig 7. Differential data-to-EOP transition skew and EOP width

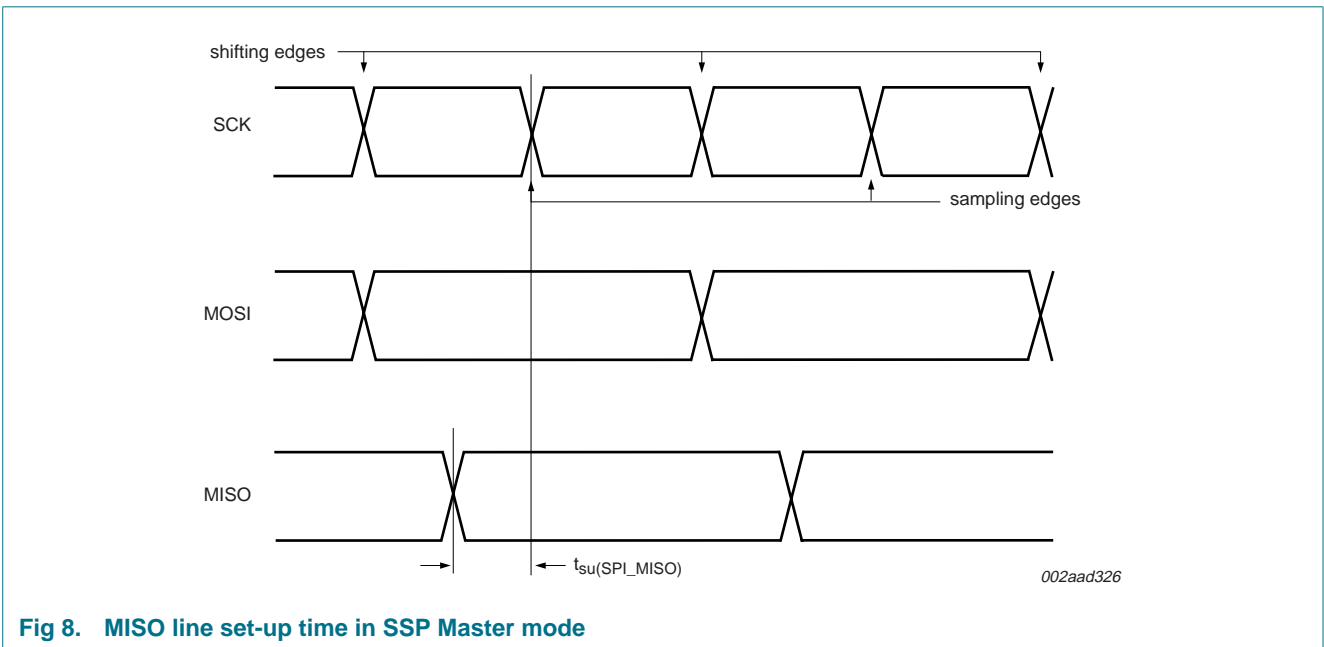

Fig 8. MISO line set-up time in SSP Master mode

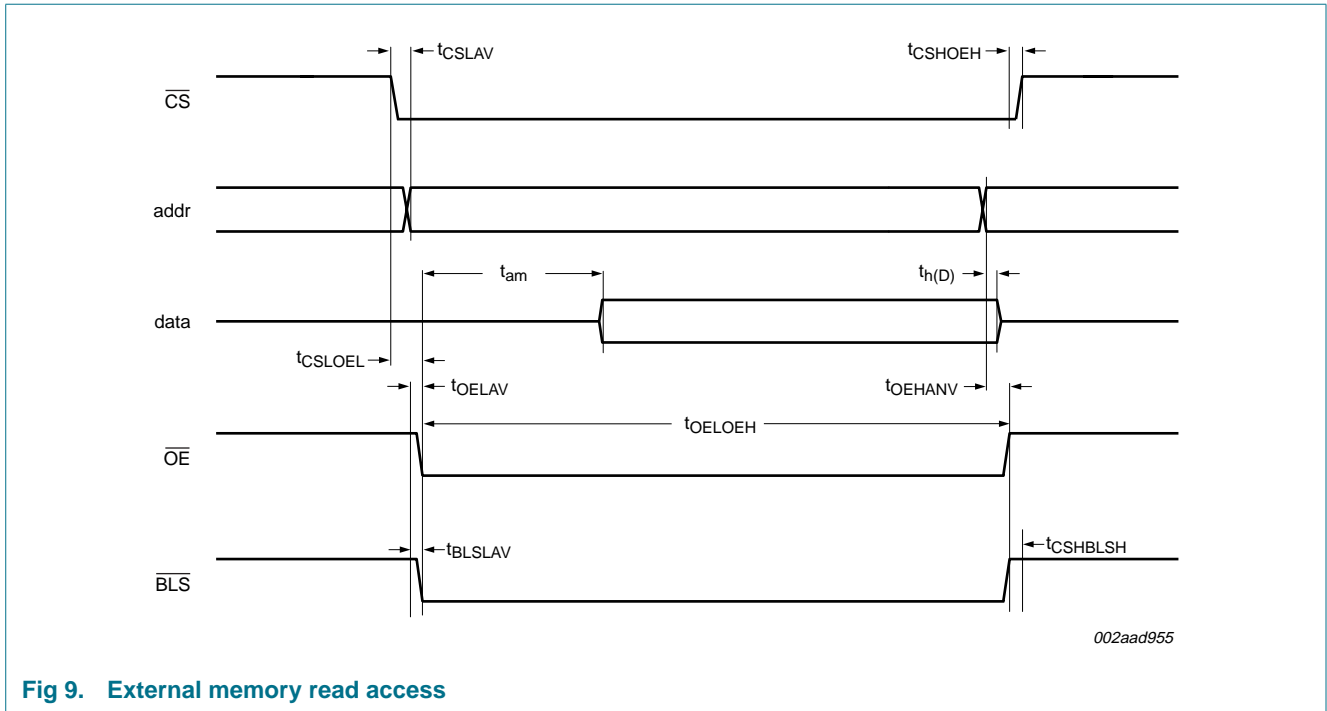

Fig 9. External memory read access

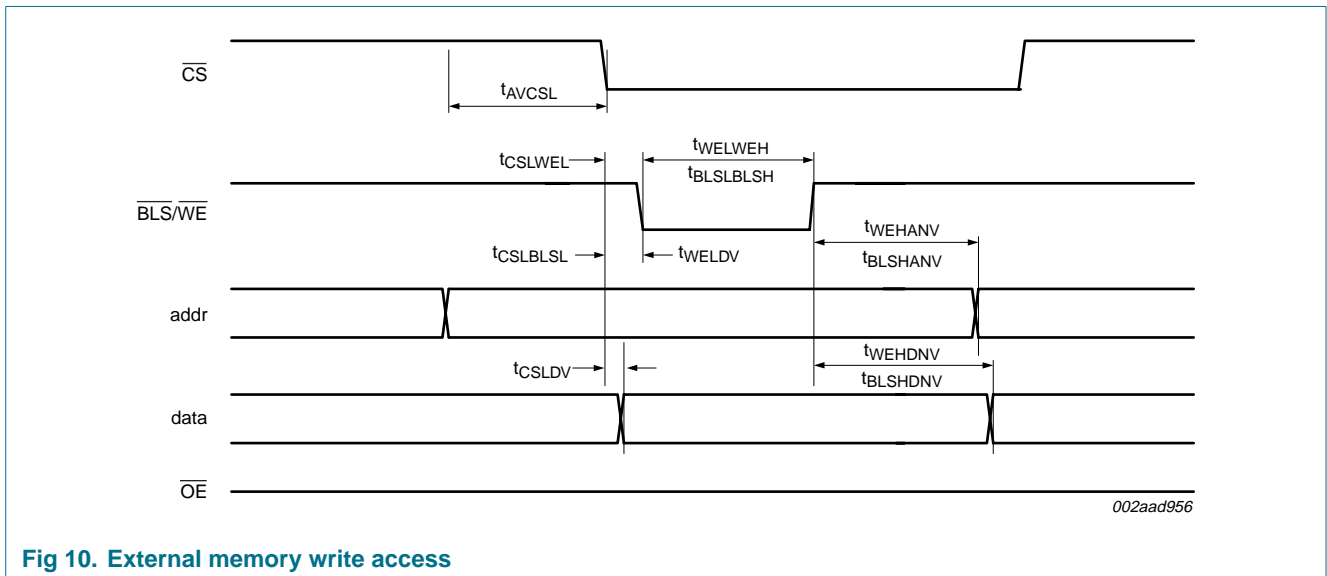

Fig 10. External memory write access

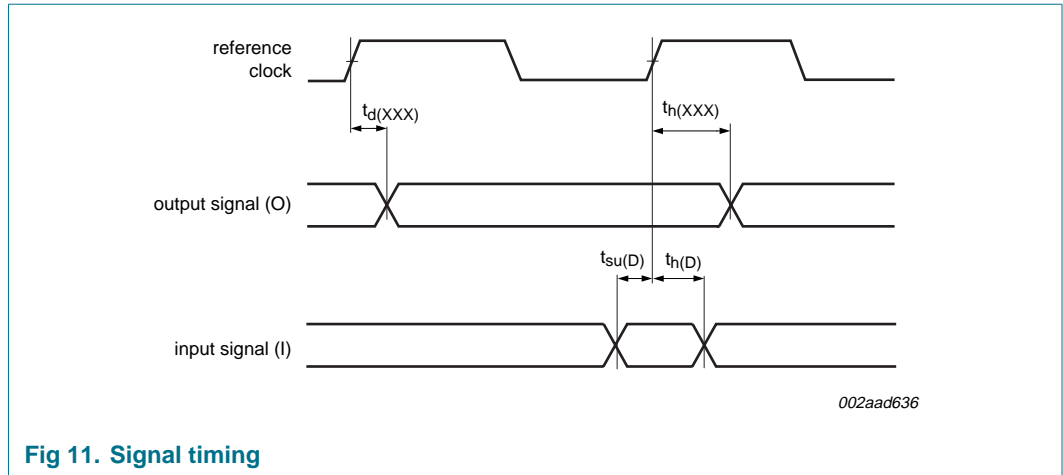

Fig 11. Signal timing

## 11. Application information

### 11.1 Suggested USB interface solutions

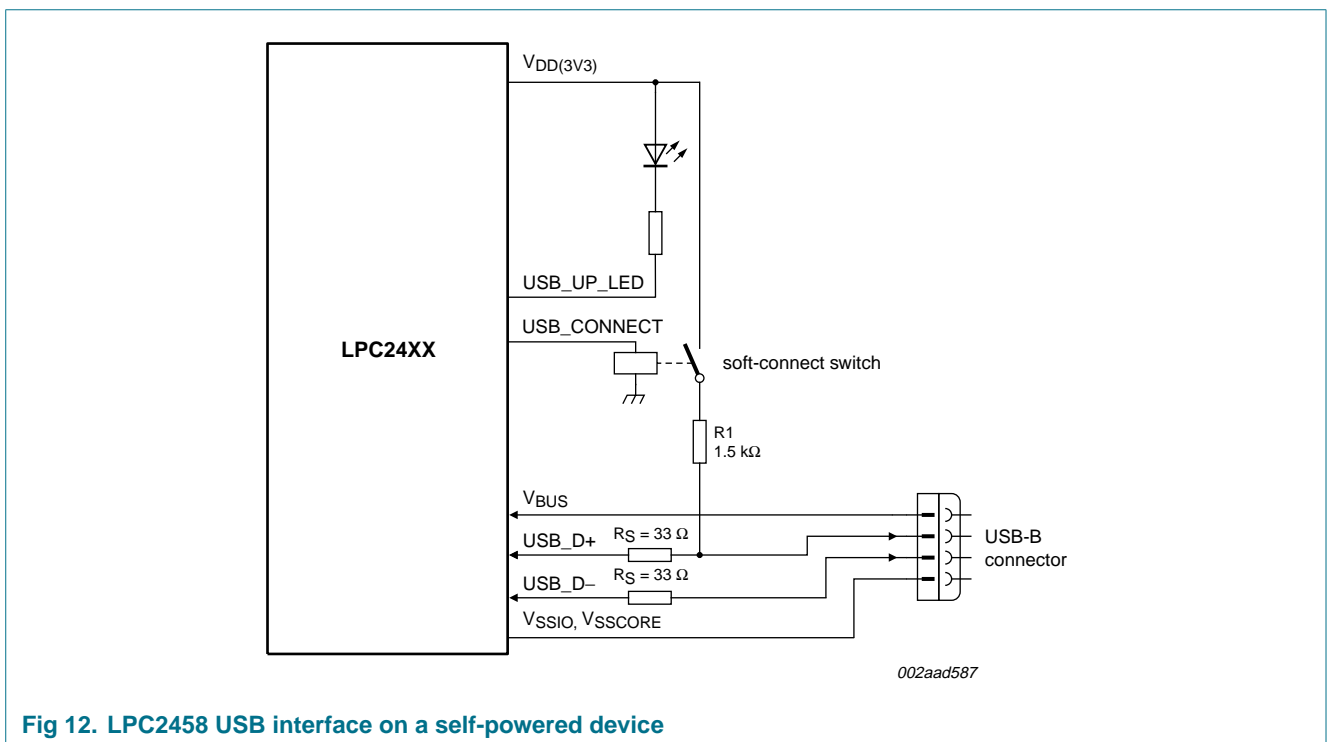

Fig 12. LPC2458 USB interface on a self-powered device



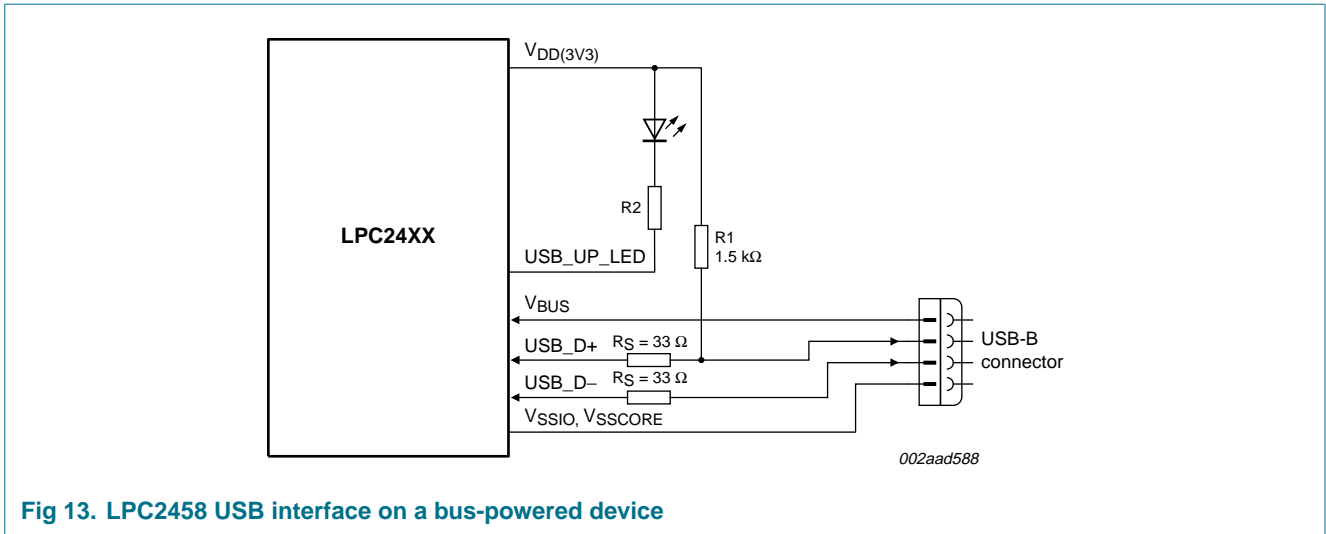
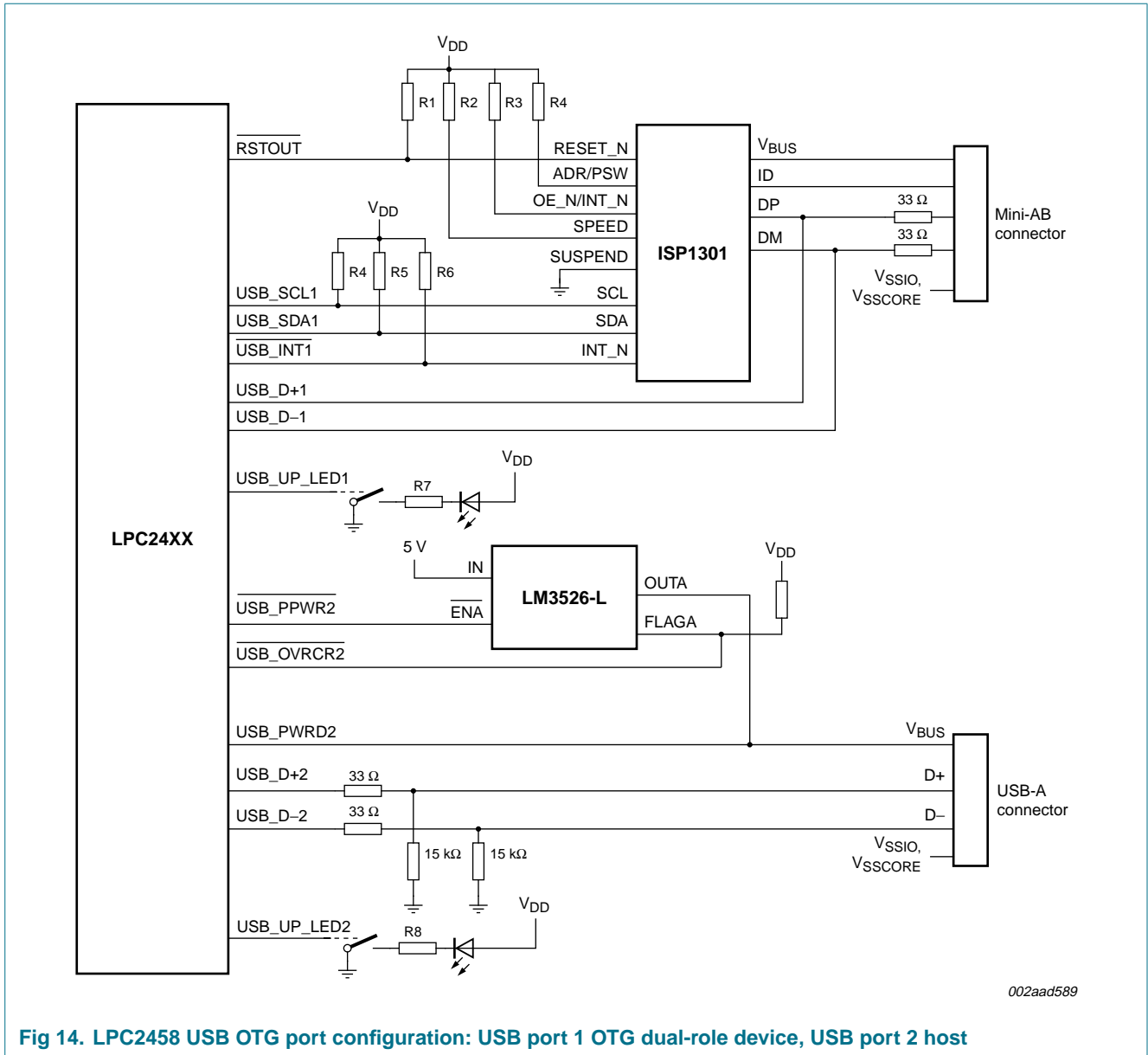
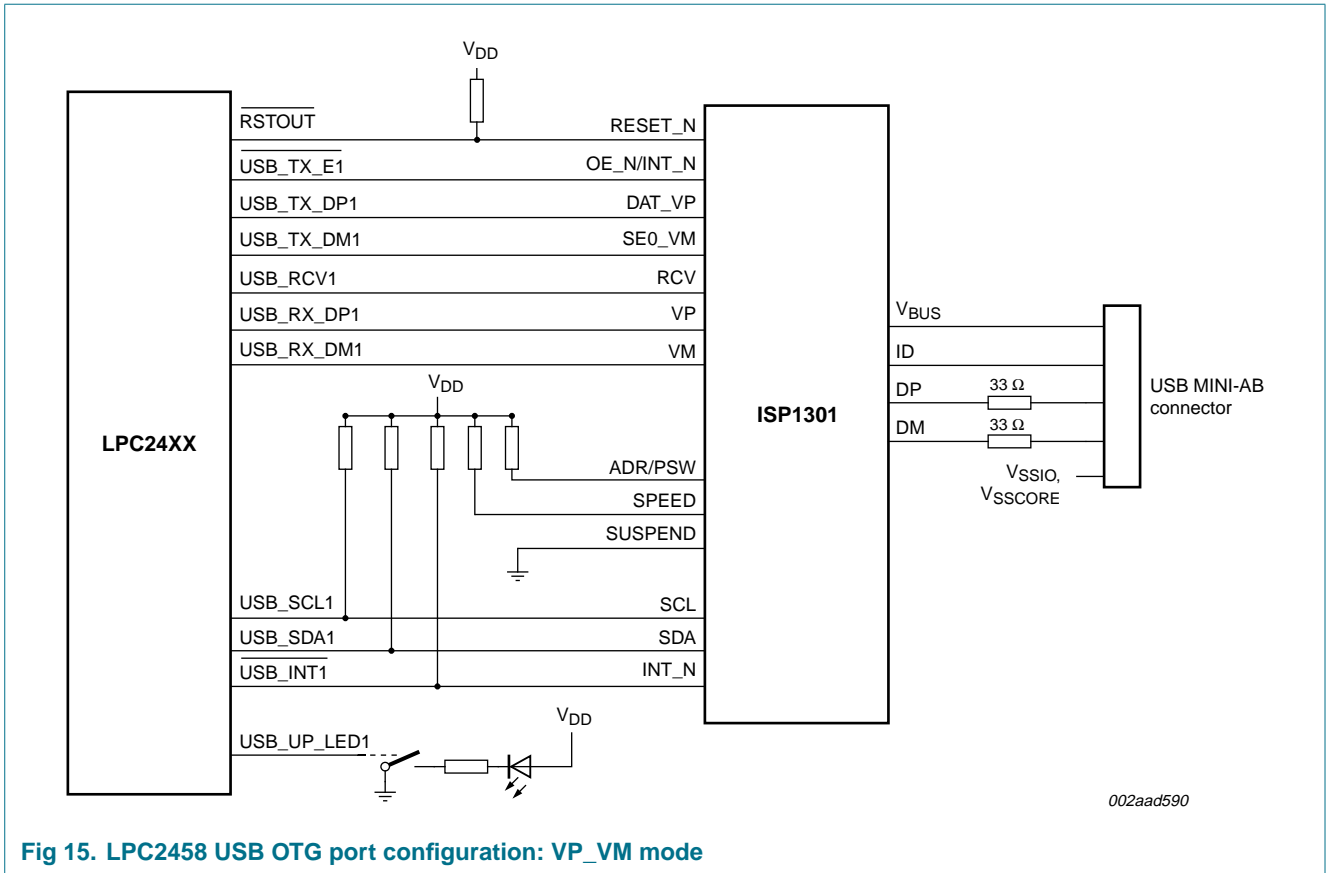

Fig 13. LPC2458 USB interface on a bus-powered device



002aad589

Fig 14. LPC2458 USB OTG port configuration: USB port 1 OTG dual-role device, USB port 2 host



002aad590

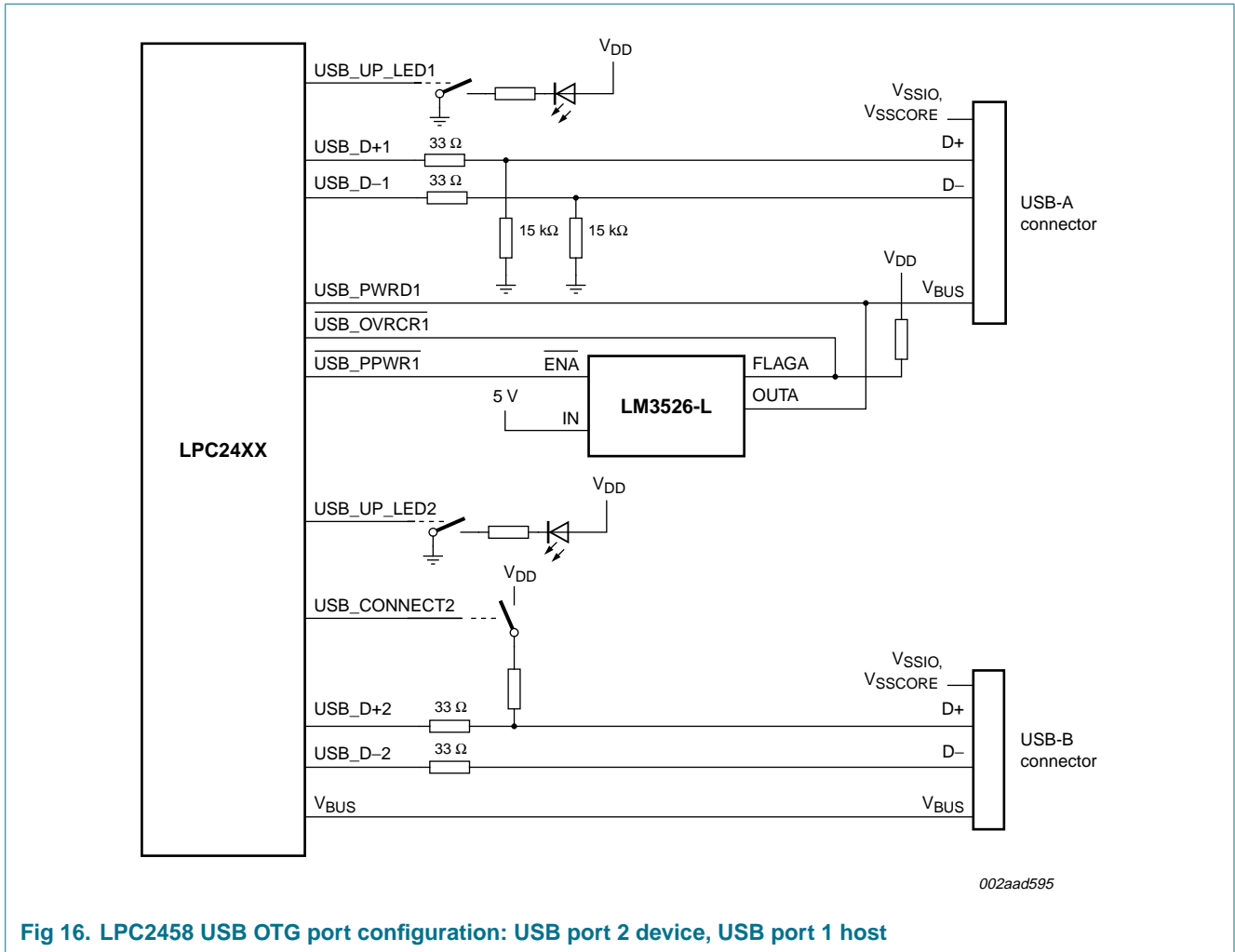

Fig 16. LPC2458 USB OTG port configuration: USB port 2 device, USB port 1 host

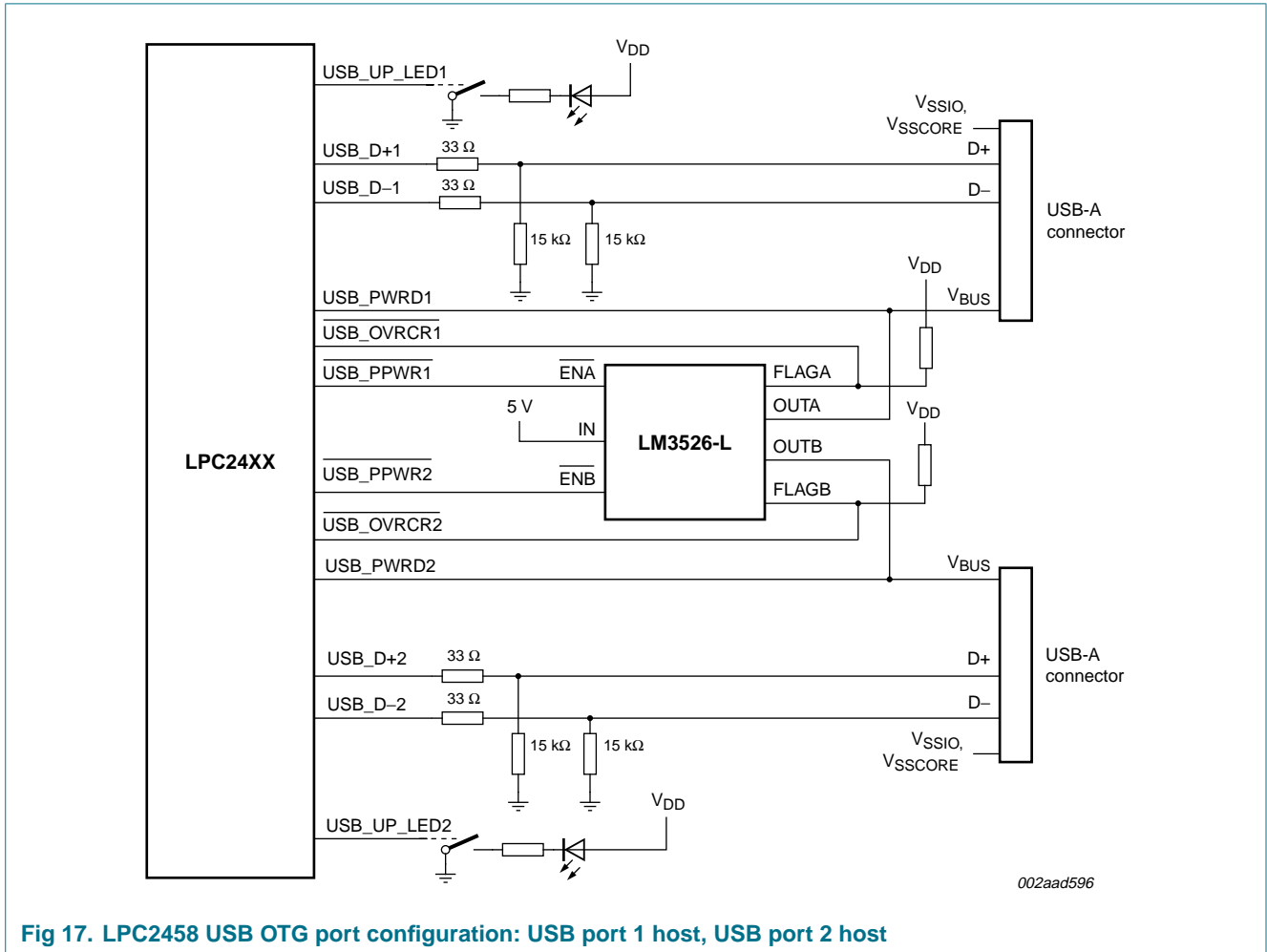

Fig 17. LPC2458 USB OTG port configuration: USB port 1 host, USB port 2 host

## 12. Package outline

TFBGA180: thin fine-pitch ball grid array package; 180 balls; body 12 x 12 x 0.8 mm

SOT570-2

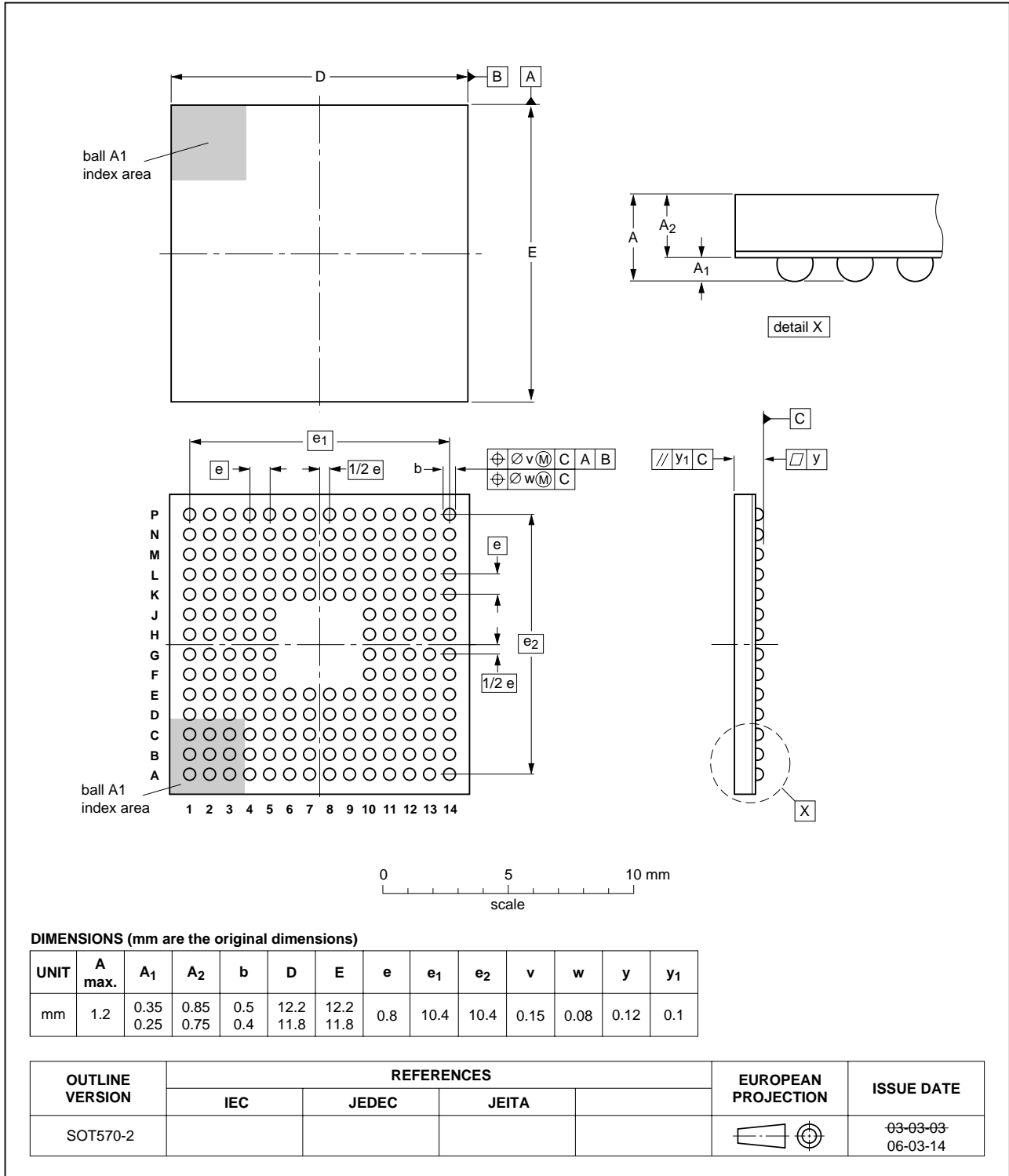

Fig 18. Package outline SOT570-2 (TFBGA180)

## 13. Abbreviations

**Table 13. Acronym list**

| Acronym | Description                                 |
|---------|---------------------------------------------|
| ADC     | Analog-to-Digital Converter                 |
| AHB     | Advanced High-performance Bus               |
| AMBA    | Advanced Microcontroller Bus Architecture   |
| APB     | Advanced Peripheral Bus                     |
| BOD     | BrownOut Detection                          |
| CAN     | Controller Area Network                     |
| DAC     | Digital-to-Analog Converter                 |
| DCC     | Debug Communication Channel                 |
| DMA     | Direct Memory Access                        |
| EOP     | End Of Packet                               |
| ETM     | Embedded Trace Macrocell                    |
| GPIO    | General Purpose Input/Output                |
| IrDA    | Infrared Data Association                   |
| JTAG    | Joint Test Action Group                     |
| MII     | Media Independent Interface                 |
| OHC     | Open Host Controller                        |
| OHCI    | Open Host Controller Interface              |
| OTG     | On-The-Go                                   |
| PHY     | Physical Layer                              |
| PLL     | Phase-Locked Loop                           |
| PWM     | Pulse Width Modulator                       |
| RMII    | Reduced Media Independent Interface         |
| SD/MMC  | Secure Digital/MultiMediaCard               |
| SE0     | Single Ended Zero                           |
| SPI     | Serial Peripheral Interface                 |
| SSI     | Synchronous Serial Interface                |
| SSP     | Synchronous Serial Port                     |
| TTL     | Transistor-Transistor Logic                 |
| UART    | Universal Asynchronous Receiver/Transmitter |
| USB     | Universal Serial Bus                        |

## 14. Revision history

**Table 14. Revision history**

| Document ID    | Release date | Data sheet status                                                                                                                                                                                                                                                                                                                                                                                                                                                                                                                                                        | Change notice | Supersedes |
|----------------|--------------|--------------------------------------------------------------------------------------------------------------------------------------------------------------------------------------------------------------------------------------------------------------------------------------------------------------------------------------------------------------------------------------------------------------------------------------------------------------------------------------------------------------------------------------------------------------------------|---------------|------------|
| LPC2458_2      | 20081125     | Product data sheet                                                                                                                                                                                                                                                                                                                                                                                                                                                                                                                                                       | -             | LPC2458_1  |
| Modifications: |              | <ul style="list-style-type: none"><li>• Added <a href="#">Table 11 “Dynamic characteristics: Static external memory interface”</a>.</li><li>• Added <a href="#">Table 12 “Dynamic characteristics: Dynamic external memory interface”</a>.</li><li>• Added <a href="#">Figure 9 “External memory read access”</a>.</li><li>• Added <a href="#">Figure 10 “External memory write access”</a>.</li><li>• <a href="#">Table 7</a>, <math>V_{hys}</math>, moved 0.4 from Typ to Min column.</li><li>• <a href="#">Table 7</a>, added <a href="#">Table note 6</a>.</li></ul> |               |            |
| LPC2458_1      | 20080623     | Product data sheet                                                                                                                                                                                                                                                                                                                                                                                                                                                                                                                                                       | -             | -          |



## 15. Legal information

### 15.1 Data sheet status

| Document status <sup>[1][2]</sup> | Product status <sup>[3]</sup> | Definition                                                                            |
|-----------------------------------|-------------------------------|---------------------------------------------------------------------------------------|
| Objective [short] data sheet      | Development                   | This document contains data from the objective specification for product development. |
| Preliminary [short] data sheet    | Qualification                 | This document contains data from the preliminary specification.                       |
| Product [short] data sheet        | Production                    | This document contains the product specification.                                     |

[1] Please consult the most recently issued document before initiating or completing a design.

[2] The term 'short data sheet' is explained in section "Definitions".

[3] The product status of device(s) described in this document may have changed since this document was published and may differ in case of multiple devices. The latest product status information is available on the Internet at URL <http://www.nxp.com>.

### 15.2 Definitions

**Draft** — The document is a draft version only. The content is still under internal review and subject to formal approval, which may result in modifications or additions. NXP Semiconductors does not give any representations or warranties as to the accuracy or completeness of information included herein and shall have no liability for the consequences of use of such information.

**Short data sheet** — A short data sheet is an extract from a full data sheet with the same product type number(s) and title. A short data sheet is intended for quick reference only and should not be relied upon to contain detailed and full information. For detailed and full information see the relevant full data sheet, which is available on request via the local NXP Semiconductors sales office. In case of any inconsistency or conflict with the short data sheet, the full data sheet shall prevail.

### 15.3 Disclaimers

**General** — Information in this document is believed to be accurate and reliable. However, NXP Semiconductors does not give any representations or warranties, expressed or implied, as to the accuracy or completeness of such information and shall have no liability for the consequences of use of such information.

**Right to make changes** — NXP Semiconductors reserves the right to make changes to information published in this document, including without limitation specifications and product descriptions, at any time and without notice. This document supersedes and replaces all information supplied prior to the publication hereof.

**Suitability for use** — NXP Semiconductors products are not designed, authorized or warranted to be suitable for use in medical, military, aircraft, space or life support equipment, nor in applications where failure or malfunction of an NXP Semiconductors product can reasonably be expected to result in personal injury, death or severe property or environmental

damage. NXP Semiconductors accepts no liability for inclusion and/or use of NXP Semiconductors products in such equipment or applications and therefore such inclusion and/or use is at the customer's own risk.

**Applications** — Applications that are described herein for any of these products are for illustrative purposes only. NXP Semiconductors makes no representation or warranty that such applications will be suitable for the specified use without further testing or modification.

**Limiting values** — Stress above one or more limiting values (as defined in the Absolute Maximum Ratings System of IEC 60134) may cause permanent damage to the device. Limiting values are stress ratings only and operation of the device at these or any other conditions above those given in the Characteristics sections of this document is not implied. Exposure to limiting values for extended periods may affect device reliability.

**Terms and conditions of sale** — NXP Semiconductors products are sold subject to the general terms and conditions of commercial sale, as published at <http://www.nxp.com/profile/terms>, including those pertaining to warranty, intellectual property rights infringement and limitation of liability, unless explicitly otherwise agreed to in writing by NXP Semiconductors. In case of any inconsistency or conflict between information in this document and such terms and conditions, the latter will prevail.

**No offer to sell or license** — Nothing in this document may be interpreted or construed as an offer to sell products that is open for acceptance or the grant, conveyance or implication of any license under any copyrights, patents or other industrial or intellectual property rights.

### 15.4 Trademarks

Notice: All referenced brands, product names, service names and trademarks are the property of their respective owners.

**I<sup>2</sup>C-bus** — logo is a trademark of NXP B.V.

**SoftConnect** — is a trademark of NXP B.V.

**GoodLink** — is a trademark of NXP B.V.

## 16. Contact information

For more information, please visit: <http://www.nxp.com>

For sales office addresses, please send an email to: [salesaddresses@nxp.com](mailto:salesaddresses@nxp.com)

17. Contents

|          |                                                      |           |           |                                                                    |           |
|----------|------------------------------------------------------|-----------|-----------|--------------------------------------------------------------------|-----------|
| <b>1</b> | <b>General description</b> . . . . .                 | <b>1</b>  | 7.19.1    | Features . . . . .                                                 | 32        |
| <b>2</b> | <b>Features</b> . . . . .                            | <b>1</b>  | 7.20      | I <sup>2</sup> S-bus serial I/O controllers . . . . .              | 32        |
| <b>3</b> | <b>Applications</b> . . . . .                        | <b>3</b>  | 7.20.1    | Features . . . . .                                                 | 33        |
| <b>4</b> | <b>Ordering information</b> . . . . .                | <b>3</b>  | 7.21      | General purpose 32-bit timers/external<br>event counters . . . . . | 33        |
| 4.1      | Ordering options . . . . .                           | 3         | 7.21.1    | Features . . . . .                                                 | 33        |
| <b>5</b> | <b>Block diagram</b> . . . . .                       | <b>4</b>  | 7.22      | Pulse width modulator . . . . .                                    | 34        |
| <b>6</b> | <b>Pinning information</b> . . . . .                 | <b>5</b>  | 7.22.1    | Features . . . . .                                                 | 34        |
| 6.1      | Pinning . . . . .                                    | 5         | 7.23      | Watchdog timer (WDT). . . . .                                      | 35        |
| 6.2      | Pin description . . . . .                            | 8         | 7.23.1    | Features . . . . .                                                 | 35        |
| <b>7</b> | <b>Functional description</b> . . . . .              | <b>20</b> | 7.24      | RTC and battery RAM . . . . .                                      | 35        |
| 7.1      | Architectural overview . . . . .                     | 20        | 7.24.1    | Features . . . . .                                                 | 36        |
| 7.2      | On-chip flash programming memory . . . . .           | 21        | 7.25      | Clocking and power control . . . . .                               | 36        |
| 7.3      | On-chip SRAM . . . . .                               | 21        | 7.25.1    | Crystal oscillators . . . . .                                      | 36        |
| 7.4      | Memory map . . . . .                                 | 21        | 7.25.1.1  | Internal RC oscillator . . . . .                                   | 36        |
| 7.5      | Interrupt controller . . . . .                       | 23        | 7.25.1.2  | Main oscillator . . . . .                                          | 36        |
| 7.5.1    | Interrupt sources . . . . .                          | 24        | 7.25.1.3  | RTC oscillator . . . . .                                           | 37        |
| 7.6      | Pin connect block . . . . .                          | 24        | 7.25.2    | PLL . . . . .                                                      | 37        |
| 7.7      | External memory controller . . . . .                 | 24        | 7.25.3    | Wake-up timer . . . . .                                            | 37        |
| 7.7.1    | Features . . . . .                                   | 24        | 7.25.4    | Power control . . . . .                                            | 38        |
| 7.8      | General purpose DMA controller . . . . .             | 25        | 7.25.4.1  | Idle mode . . . . .                                                | 38        |
| 7.8.1    | Features . . . . .                                   | 25        | 7.25.4.2  | Sleep mode . . . . .                                               | 38        |
| 7.9      | Fast general purpose parallel I/O . . . . .          | 26        | 7.25.4.3  | Power-down mode . . . . .                                          | 38        |
| 7.9.1    | Features . . . . .                                   | 26        | 7.25.4.4  | Power domains . . . . .                                            | 39        |
| 7.10     | Ethernet . . . . .                                   | 27        | 7.26      | System control . . . . .                                           | 39        |
| 7.10.1   | Features . . . . .                                   | 27        | 7.26.1    | Reset . . . . .                                                    | 39        |
| 7.11     | USB interface . . . . .                              | 28        | 7.26.2    | Brownout detection . . . . .                                       | 40        |
| 7.11.1   | USB device controller . . . . .                      | 28        | 7.26.3    | Code security (Code Read Protection - CRP) . . . . .               | 40        |
| 7.11.1.1 | Features . . . . .                                   | 28        | 7.26.4    | AHB . . . . .                                                      | 40        |
| 7.11.2   | USB Host Controller . . . . .                        | 28        | 7.26.5    | External interrupt inputs . . . . .                                | 41        |
| 7.11.2.1 | Features . . . . .                                   | 28        | 7.26.6    | Memory mapping control . . . . .                                   | 41        |
| 7.11.3   | USB OTG Controller . . . . .                         | 29        | 7.27      | Emulation and debugging . . . . .                                  | 41        |
| 7.11.3.1 | Features . . . . .                                   | 29        | 7.27.1    | EmbeddedICE . . . . .                                              | 41        |
| 7.12     | CAN controller and acceptance filters . . . . .      | 29        | 7.27.2    | Embedded trace . . . . .                                           | 41        |
| 7.12.1   | Features . . . . .                                   | 29        | 7.27.3    | RealMonitor . . . . .                                              | 42        |
| 7.13     | 10-bit ADC . . . . .                                 | 30        | <b>8</b>  | <b>Limiting values</b> . . . . .                                   | <b>43</b> |
| 7.13.1   | Features . . . . .                                   | 30        | <b>9</b>  | <b>Static characteristics</b> . . . . .                            | <b>44</b> |
| 7.14     | 10-bit DAC . . . . .                                 | 30        | <b>10</b> | <b>Dynamic characteristics</b> . . . . .                           | <b>50</b> |
| 7.14.1   | Features . . . . .                                   | 30        | 10.1      | Timing . . . . .                                                   | 54        |
| 7.15     | UARTs . . . . .                                      | 30        | <b>11</b> | <b>Application information</b> . . . . .                           | <b>56</b> |
| 7.15.1   | Features . . . . .                                   | 30        | 11.1      | Suggested USB interface solutions . . . . .                        | 56        |
| 7.16     | SPI serial I/O controller . . . . .                  | 31        | <b>12</b> | <b>Package outline</b> . . . . .                                   | <b>62</b> |
| 7.16.1   | Features . . . . .                                   | 31        | <b>13</b> | <b>Abbreviations</b> . . . . .                                     | <b>63</b> |
| 7.17     | SSP serial I/O controller . . . . .                  | 31        | <b>14</b> | <b>Revision history</b> . . . . .                                  | <b>64</b> |
| 7.17.1   | Features . . . . .                                   | 31        | <b>15</b> | <b>Legal information</b> . . . . .                                 | <b>65</b> |
| 7.18     | SD/MMC card interface . . . . .                      | 31        | 15.1      | Data sheet status . . . . .                                        | 65        |
| 7.18.1   | Features . . . . .                                   | 31        |           |                                                                    |           |
| 7.19     | I <sup>2</sup> C-bus serial I/O controller . . . . . | 32        |           |                                                                    |           |

continued >>

|           |                                      |           |
|-----------|--------------------------------------|-----------|
| 15.2      | Definitions . . . . .                | 65        |
| 15.3      | Disclaimers . . . . .                | 65        |
| 15.4      | Trademarks . . . . .                 | 65        |
| <b>16</b> | <b>Contact information . . . . .</b> | <b>65</b> |
| <b>17</b> | <b>Contents . . . . .</b>            | <b>66</b> |

Please be aware that important notices concerning this document and the product(s) described herein, have been included in section 'Legal information'.



© NXP B.V. 2008.

All rights reserved.

For more information, please visit: <http://www.nxp.com>

For sales office addresses, please send an email to: [salesaddresses@nxp.com](mailto:salesaddresses@nxp.com)

Date of release: 25 November 2008

Document identifier: LPC2458\_2