

Features

- Fast switching
- Low leakage
- Low forward voltage drop
- High current capability
- High current surge
- High reliability

Mechanical Data

- Case : JEDEC ITO-220A molded plastic body
- Terminals : Lead solderable per MIL-STD-750, method 2026
- Polarity : As marked
- Mounting Position : Any
- Weight : 0.08 ounce, 2.24 gram

ITO-220A

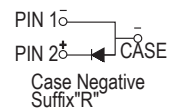
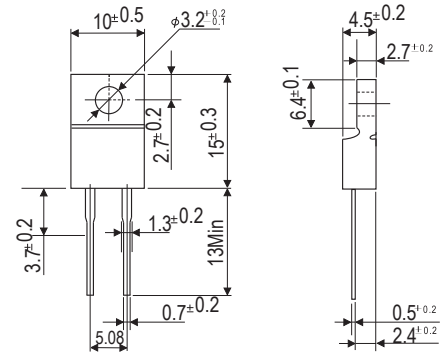

Dimensions in inches and (millimeters)

Maximum Ratings And Electrical Characteristics

(Ratings at 25 °C ambient temperature unless otherwise specified, Single phase, half wave 60Hz, resistive or inductive load. For capacitive load, derate by 20%)

	Symbols	FP 801	FP 802	FP 803	FP 804	FP 805	FP 806	FP 807	Units
Maximum recurrent peak reverse voltage	V _{RRM}	50	100	200	400	600	800	1000	Volts
Maximum RMS voltage	V _{RMS}	35	70	140	280	420	560	700	Volts
Maximum DC blocking voltage	V _{DC}	50	100	200	400	600	800	1000	Volts
Maximum average forward rectified current at T _c =55 °C	I _(AV)	8.0							Amps
Peak forward surge current 8.3ms single half sine-wave superimposed on rated load (JEDEC method)	I _{FSM}	150							Amps
Maximum instantaneous forward voltage at 8.0A	V _F	1.3							Volts
Maximum DC reverse current at rated DC blocking voltage	T _c =25 °C	10							μA
	T _c =125 °C	100							
Maximum reverse recovery time (Note 1)	T _{rr}	150			250	500		ns	
Typical junction capacitance (Note 2) T _J =25 °C	C _J	60							pF
Typical thermal resistance (Note 3)	R _{θJC}	5.0							°C/W
Operating junction and storage temperature range	T _J T _{STG}	-55 to +150							°C

Notes:

- (1) Test conditions: I_F=0.5A, I_R=1.0A, I_{rr}=0.25A.
- (2) Measured at 1MHz and applied reverse voltage of 4.0 Volts.
- (3) Thermal resistance from junction to case, single side cooled.

RATINGS AND CHARACTERISTIC CURVES FP801 THRU FP807

FIG. 1 -REVERSE RECOVERY TIME CHARACTERISTIC AND TEST CIRCUIT DIAGRAM

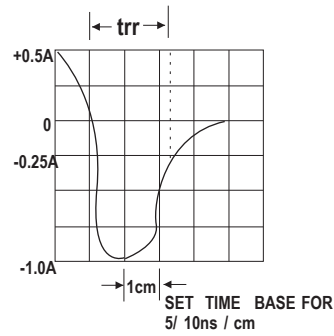
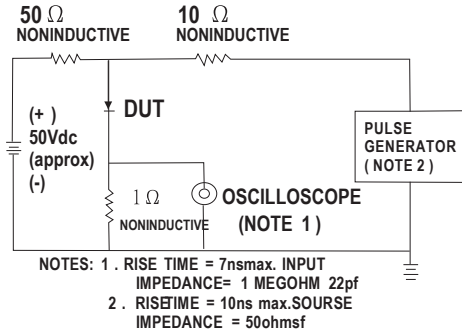

AVERAGE FORWARD CURRENT (A)

FIG. 2- MAXIMUM FORWARD CURRENT DERATING CURVE

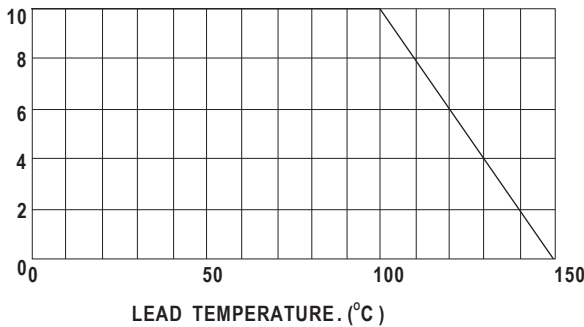

FIG. 3 -MAXIMUM NON - REPETITIVE FORWARD SURGE CURRENT

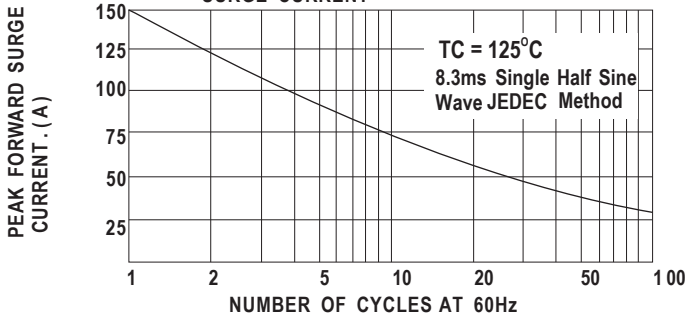

FIG. 4 -TYPICAL HUNCTION CAPACITANCE

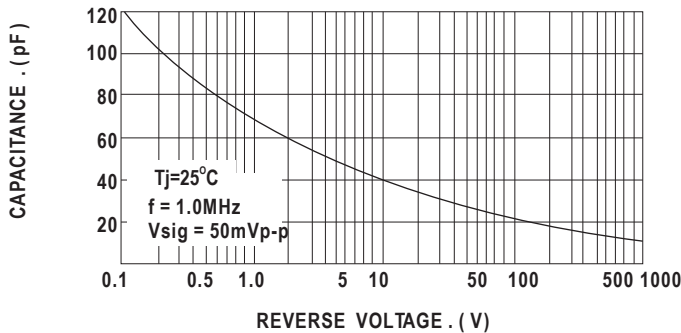

FIG. 5 -TYPICAL INSTANTANEOUS FORWARD CHARACTERISTICS

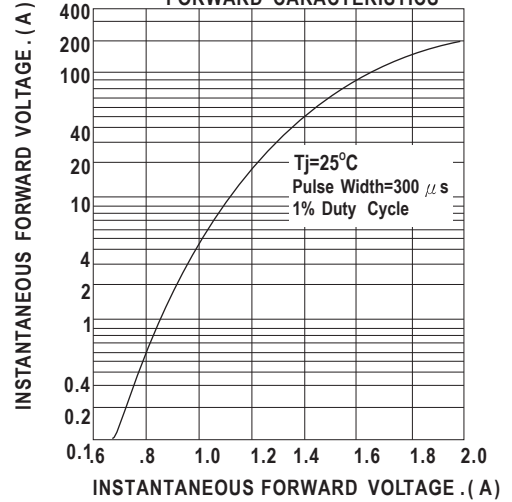

FIG. 6 -TYPICAL REVERSE CHARACTERISTICS

