

RoHS Compliant Product

A suffix of "-C" specifies halogen-free and RoHS Compliant

FEATURES

- Batch process design, excellent power dissipation offers better reverse leakage current and thermal resistance.
- Low profile surface mounted application in order to optimize board space.
- Tiny plastic SMD package.
- High current capability.
- Fast switching for high efficiency.
- High surge current capability.
- Glass passivated chip junction.
- Lead-free parts meet RoHS requirements.
- Suffix "-H" indicates Halogen-free parts, ex. SMF101MH-H

SOD-123MH

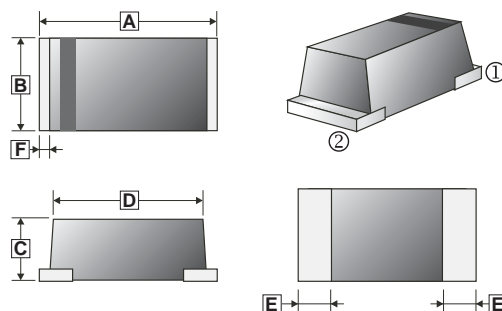

MECHANICAL DATA

- Epoxy : UL94-V0 rated flame retardant
- Case : Molded plastic, SOD-123MH
- Terminals : Plated terminals, solderable per MIL-STD-750, Method 2026
- Polarity : Indicated by cathode band
- Mounting Position : Any
- Weight : Approximated 0.011 gram

REF.	Millimeter		REF.	Millimeter	
	Min.	Max.		Min.	Max.
A	3.30	3.70	D	3.10 (MAX.)	
B	1.40	1.80	E	0.80 (TYP.)	
C	0.60	1.00	F	0.30 (TYP.)	



MARKING

Product	Marking Code	Product	Marking Code
SMF101MH	F1	SMF105MH	F5
SMF102MH	F2	SMF106MH	F6
SMF103MH	F3	SMF107MH	F7
SMF104MH	F4		

PACKAGE INFORMATION

Package	MPQ	LeaderSize
SOD-123MH	3K	7' inch

MAXIMUM RATINGS ($T_A=25^\circ\text{C}$ unless otherwise noted)

PARAMETERS	SYMBOL	PART NUMBERS							UNITS
		SMF 101MH	SMF 102MH	SMF 103MH	SMF 104MH	SMF 105MH	SMF 106MH	SMF 107MH	
Maximum repetitive peak reverse voltage	V_{RRM}	50	100	200	400	600	800	1000	V
Maximum RMS voltage	V_{RMS}	35	70	140	280	420	560	700	V
Maximum Continuous reverse voltage	V_R	50	100	200	400	600	800	1000	V
Maximum Instantaneous Forward Voltage	V_F	1.30							V
Maximum average forward rectified current @ $T_A=55^\circ\text{C}$	I_O	1.0							A
Peak Forward Surge Current, 8.3ms single half sine-wave superimposed on rated load (JEDEC method)	I_{FSM}	25							A
Maximum DC Reverse Current at Rated DC @ $T_A=25^\circ\text{C}$	I_R	5.0							μA
Blocking Voltage @ $T_A=100^\circ\text{C}$		100							
Diode Junction Capacitance (Note 1)	C_J	15							pF
Maximum Reverse Recovery Time	T_{rr}	150			250	500		nS	
Thermal resistance Junction to ambient	$R_{\theta JA}$	42							$^\circ\text{C} / \text{W}$
Operating Temperature	T_J	-65 ~ 150							$^\circ\text{C}$
Storage Temperature	T_{STG}	-65 ~ 175							$^\circ\text{C}$

NOTES:

1. Measured at 1.0MHz and applied reverse voltage of 4.0V D.C.

CHARACTERISTIC CURVES

FIG.1-TYPICAL FORWARD CHARACTERISTICS

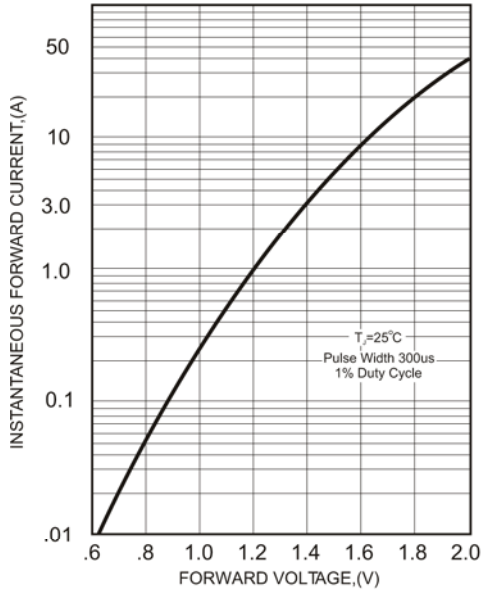

FIG.2-TYPICAL FORWARD CURRENT DERATING CURVE

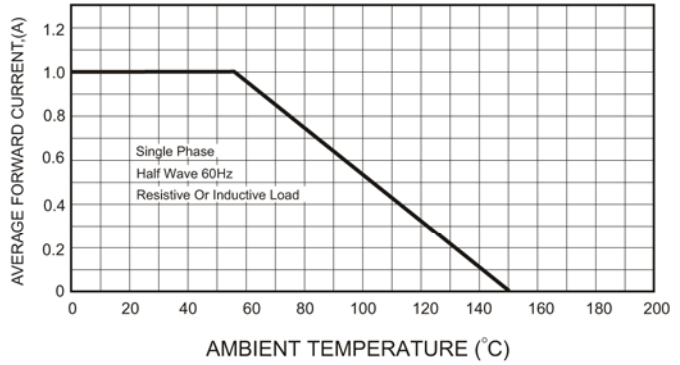
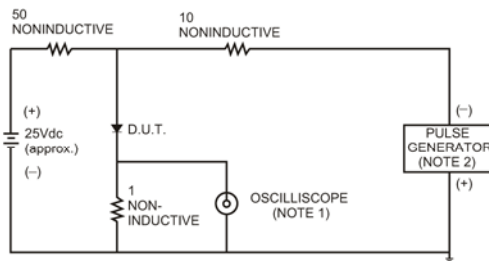

FIG.3- TEST CIRCUIT DIAGRAM AND REVERSE RECOVERY TIME CHARACTERISTICS



NOTES: 1. Rise Time= 7ns max., Input Impedance= 1 megohm.22pF.
2. Rise Time= 10ns max., Source Impedance= 50 ohms.

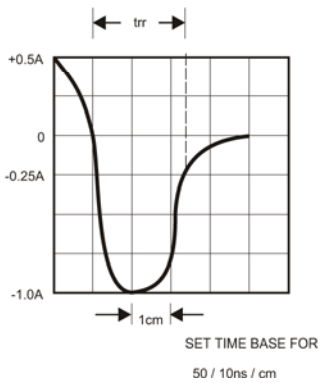

FIG.4-MAXIMUM NON-REPETITIVE FORWARD SURGE CURRENT

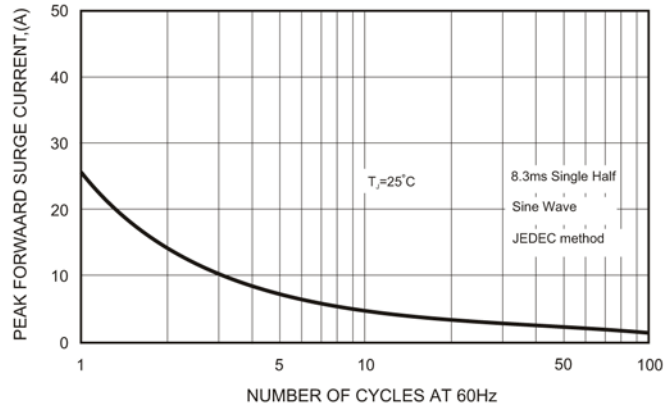

FIG.5-TYPICAL JUNCTION CAPACITANCE

