

LINEAR INTEGRATED CIRCUIT

VOICE SWITCHED SPEAKER- PHONE CIRCUIT

DESCRIPTION

The Contek KGM34018 speaker-phone integrated circuit incorporates the necessary functions to produce a high quality hands-free speaker-phone system. The applications include household and office speaker-phones, intercom systems, hand free kit for mobile phones, and others

FEATURES

- *All necessary level detection and attenuation controls for a hand-free telephone included.
- *Background noise level monitoring with long time constant.
- *Background sound level compensation for transmit and receive levels as well as the background level.
- *Wide operating dynamic range through signal compression.
- *On-chip voltage regulators illuminate external regulators for lining operation.
- *Power audio amplifier for typical 100mW output (into 25 ohms) with peak limiting for speaker to minimize distortion.
- *Chip Select pin for active/stand by operation.
- *Volume control function for external volume control.
- *Standard 28-pin plastic DIP and SOP package.

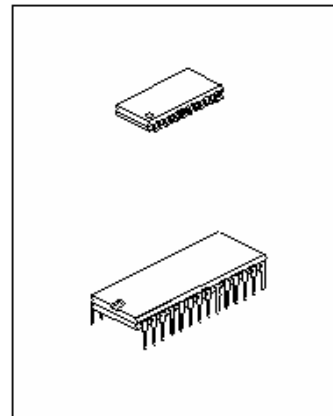
SOP-28
DIP-28

ABSOLUTE MAXIMUM RATINGS (Ta=25 °C, Voltages referred to pin 22)

PARAMETER	VALUE	UNIT
V+ terminal Voltage (pin 16)	+12, -1.0	V
CS (pin 18)	+12, -1.0	V
Speaker amplifier Ground (pin 14)	+3.0, -1.0	V
VLC (pin 24)	+VCC, -1.0	V
Storage temperature	-65 ~ +150	C

RECOMMENDED OPERATION CONDITIONS

PARAMETER	VALUE	UNIT
V+ Terminal Voltage (pin 16)	+6.0 to +11	V
CS (pin 18)	0 to +11	V
Vcc (pin 20)	0 to 3.0	mA
VLC (pin 24)	0.55VB to VB	V
Receive Signal (pin 27)	0 to 250	mVrms
Microphone Signal (pin 9)	0 to 5.0	mVrms
Speaker Amplifier Ground (pin 14)	-10 to +10	mVdc
Ambient Temperature	-20 to +60	C

Internal Block Diagram

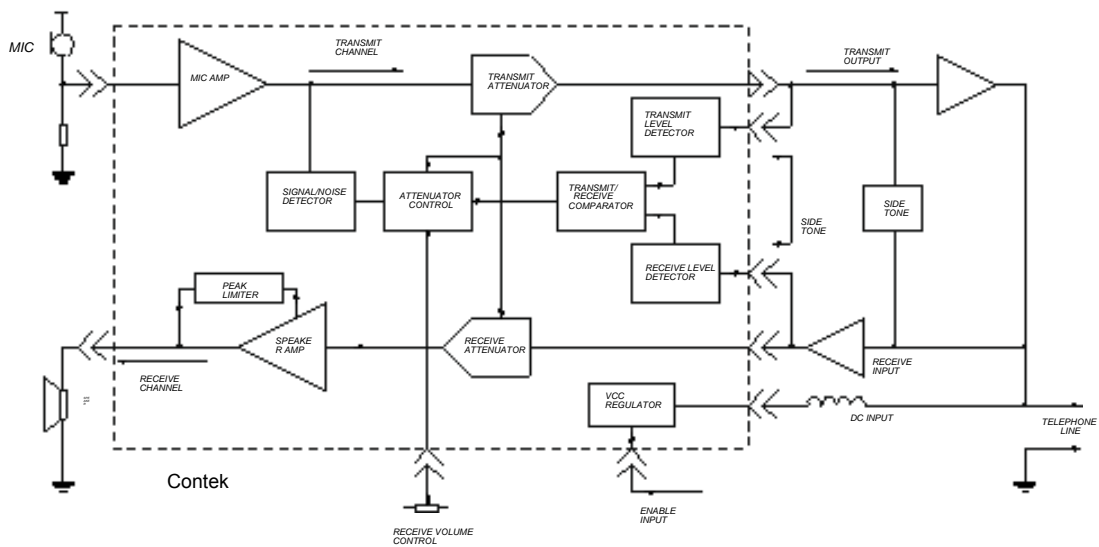

Fig 1

PIN CONFIGURATIONS

PIN	NAME	DESCRIPTION
1	RR	A resistor to ground provides a reference current for the transmit and receive attenuators
2	RTX	A resistor to ground determines the nominal gain of the transmit attenuator, the transmit channel gain is inversely proportional to RTX resistance.
3	TXI	Input to the transmit attenuator. Input resistance is nominally 5.0k ohms.
4	TXO	Output of the transmit attenuator. The TXO output signal drives the input of transmit level detector, as well as the external circuit which drives the telephone line.
5	TLI	Input of the transmit level detector. An external resistor ac coupled to The TLI pin sets the detection level. Decreasing this resistor increases the sensitivity to transmit channel signals.
6	TLO	Output of the transmit level detector. The external resistor and capacitor set the time the comparator will hold the system in the transmit mode after speech ceases.
7	RLI	Input of the receive level detector. An external resistor ac coupled to The RLI pin sets the detection level. Decreasing this resistor increases the sensitivity to receive channel signals
8	RLO	Output of the receive level detector. The external resistor and capacitor set the time the comparator will hold the system in the receive mode after speech ceases
9	MCI	Microphone amplifier input. Input impedance is nominally 10k ohms and the dc bias voltage is approximately equal to VB
10	MCO	Microphone amplifier output. The MIC amp gain is internally set at 34dB(50V/V)
11	CP1	A parallel resistor and capacitor connected between this pin and VCC holds a voltage corresponding to the background noise level. The transmit detector compares the CP1 voltage with the speech signal from
12	CP2	A capacitor at this pin peak detects the speech signals for comparison with the background noise level held at CP1.
13	XDI	Input to the transmit detector system. The microphone amplifier output is ac coupled to the XDI pin through an external resistor
14	SKG	High current ground pin for the speaker amplifier output stage. The SKG voltage should be within 10mV of the ground voltage at pin 22
15	SKO	Speaker amplifier output. The SKO pin will source and sink up to 100mA when ac coupled to the speaker. The speaker amplifier gain is internally set at 34dB(50V/V).
16	V+	Input DC supply voltage. V+ can be powered from Tip and Ring if an ac decoupling inductor is used to prevent loading ac line signals. The required V+ voltage is 6.0V to 11V(7.5V nominal) at 7.0mA
17	AGC	A capacitor from this pin to VB stabilizes the speaker amplifier gain control loop, and additionally controls the attack and decay time of this circuit. The gain control loop limits the speaker amplifier input to prevent clipping at SKO. The internal resistance at AGC pin is nominally 110k ohms.
18	CS	Digital chip select input. When at a logic "0" (<0.7V) the VCC regulator is enabled. When at a logic "1" (>1.6V), the chip is in the standby mode drawing 0.5mA. An open CS pin is a logic "0". Input impedance is nominally 140k ohms. The input voltage should not exceed 11V
19	SKI	Input to the speaker amplifier. Input impedance is nominally 20k ohms
20	VCC	A 5.4V regulated output which powers all circuits except the speaker amplifier output stage
21	VB	An output voltage equal to approximately VCC/2 which series as an analog ground for the speakerphone system. Up to 1.5mA of external load current may be sourced from VB. Output impedance is 250 ohms. A filter capacitor is required
22	GND	Ground pin for the IC(except the speaker amplifier)

(continued)

PIN	NAME	DESCRIPTION
23	XDC	Transmit detector output. A resistor and capacitor at his pin hold the system in the transmit mode during pauses between words or phrases. When the XDC pin voltage decays to ground, the attenuators switch from the transmit mode to idle mode. The internal resistor at XDC is nominally 2.6k ohms(see fig.1).
24	VLC	Volume control input>connecting this pin to the slider of a variable resistor provides receive mode volume control. The VLC pin voltage should be less than or equal to VB
25	ACF	Attenuator control filter. A capacitor connected to this pin reduces noise transient as the attenuator control switches level of attenuation
26	RXO	Output of the receive attenuator. Normally this pin is ac coupled to the input of the speaker amplifier
27	RXI	Input of the receive attenuator. Input impedance is nominally is 5.0k ohms
28	RRX	A resistor to ground determines the nominal gain of the receive attenuator. The receive channel gain is directly proportional to the RRX resistance

ELECTRICAL CHARACTERISTICS(referred to fig. 1)

PARAMETER	SYMBOL	MIN	TYP	MAX	UNIT
SUPPLY VOLTAGES					
V+ Supply Current	IV+			9.0	mA
V+=11V, Pin 18=0.7V				800	A
V+=11V, Pin 18=1.6V					
VCC Voltage (V+=7.5V)	Vcc	4.9	5.4	5.9	Vdc
Line	VccLN		65	150	MV
Regulation (6.5V<V+<11V)	RoVcc		6.0	20	ohms
Output Resistance (Icc=3mA)	Vccsat		80	300	mV
VB Voltage(V+=7.5V)	Vb	2.5	2.9	3.3	Vdc
Output Resistance (Ib=1.7mA)	Rovb		250		ohms
ATTENUATORS					
Receive Attenuator Gain (1.0kHz)	GRX	2.0	6.0	10	dB
Rx Mode, Pin 24= VB, Pin 27 = 250Mvrms					
Range (Rx to Tx Modes)	GRX	40	44	48	dB
Idle Mode, Pin 27= 250mVrms	GRI	-20	-16	-12	dB
RXO Voltage (Rx Mode)	VRXO	1.8	2.3	3.2	mV
Delta RXO Voltage (Switch from Rx to Tx Mode)	VRXO			100	mV
RXO Sink Current (Rx mode)	IRXOL	75			A
TXO Source Current (Tx mode)	ITXOH	1.0		3.0	mA
TXO Input Resistance	RTXI	3.5	5.0	8.0	k
ACF Voltage (VCC-Pin 25 Voltage)	VACF				
Rx Mode			150		mV
Tx Mode			6.0		mV
Idle Mode			75		mV
SPEAKER AMPLIFIER					
Speaker Amp Gain (pin 19 = 20mVrms)	GSPK	33	34	35	dB
SKI Input Resistance	RSKI	15	22	37	k
SKO Voltage (Pin 19 =Cap couple to GND)	VSKO	2.4	3.0	3.6	Vdc
SKO High Voltage (Pin 19 = 0.1V, -60mA Load at Pin 15)	VSKOH	5.5			Vdc
SKO Low Voltage (pin 19=0.1V, +60mA Load at Pin 15)	VSKOL			600	mV
MICROPHONE AMPLIFIER					
Microphone Amp Gain (Pin 9 = 10mVrms,1KHz)	GMCI	32.5	34	35	dB
Microphone Amp Input Resistance	RMCI	6.5	10	16	k
LOGAMPS					
RLO Leakage Current (Pin 8 = VB+1.0V)	ILKRL0			2.0	A
TLO Leakage Current (Pin 6 = VB+1.0V)	ILKTLO			2.0	A
Transmit-Receive Switching Threshold (Ratio of ITLI to IRLI - at 20 A - to Switch Tx-Rx Comparator)	ITH	25			
TRANSMIT DETECTOR					
XDC Voltage	VXDC		0		Vdc
Idle Mode			4.0		Vdc
Tx Mode					
CP2 Current Source	ICP2	5.0	10	13	A
Distortion					
Rx Mode					
RXI to SKO (pin 27 = 10mVrms,1KHz)	RXD		1.5		%
Tx Mode					
MCI to TXO (Pin 9 = 5mVrms,1KHz)	TXD		2.0		%

Note 1: V+=7.5V, CS =0.7V except where noted.

Note 2: Rx mode: pin7=-100 A, pin5=+100 A, except where noted

Tx mode: pin 5,13=-100 A, pin 7=+100 A, pin 11=0V. Idle mode: Pin 5=-100A, pin 7,13=+100 A

Note 3: Current into a pin designed as +, current out of a pin designed -;

Note 4: Voltage referred to pin 22, Tamb=25 C

TEMPERATURE CHARACTERISTICS(-20 TO +60 C)

PARAMETER	PIN	TYP CHANGE	UNIT
V+ Supply Current (V+ 11V,Pin 18 = 0.7V)	16	-0.2	%/ C
V+ Supply Current(V+ 11V,Pin 18 = 1.6V)	16	-0.4	%/ C
VCC Voltage(V+ = 7.5V)	20	+0.1	%/ C
Attenuator Gain (Max and Min Setting)		+0.003	dB/ C
Delta RXO,TXO Voltage	4,26	+0.24	%/ C
Speaker AMP Gain	15,19	+0.001	dB/ C
Microphone AMP Gain	9,10	+0.4	dB/ C
Microphone Amp Input Resistance	9	+0.4	%/ C
Tx-Rx Switching Threshold (20 A)	5,7	+0.2	nA/ C

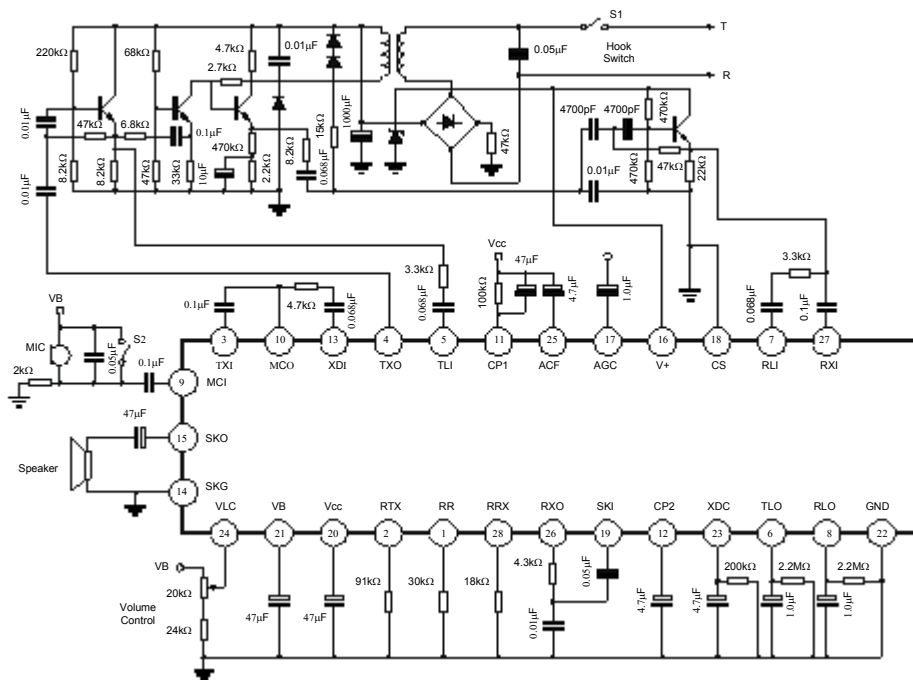
Fig 2 - Basic Line powered Speakerphone