

DO NOT SCALE FROM THIS PRINT

-XX	-S, -D, -T, -P	-S-RA, -P-RA	-D-RA	-T-RA
-01	C-08-1-XXX	N/A	N/A	N/A
-02	C-08-2-XXX	C-08-2-XXX	C-08-2-XXX C-08-3-XXX	C-08-2-XXX C-08-3-XXX C-08-5-XXX
-03	C-08-3-XXX	C-08-3-XXX	C-08-3-XXX C-08-5-XXX	N/A
-04	C-08-5-XXX	C-08-5-XXX	N/A	N/A
-06	C-08-6-XXX	N/A	N/A	N/A
-21	C-17-1-XXX	N/A	N/A	N/A
-22	C-17-2-XXX	C-17-2-XXX	C-17-2-XXX C-17-3-XXX	C-17-2-XXX C-17-3-XXX C-17-5-XXX
-23	C-17-3-XXX	C-17-3-XXX	C-17-3-XXX C-17-5-XXX	N/A
-24	C-17-5-XXX	C-17-5-XXX	N/A	N/A

LEAD STYLE	"B"	"C" REF		
	-S(-RA), -D, -T	-S-RA	-D-RA	-T-RA
-01, -21	.104 [2.64]	N/A	N/A	N/A
-02, -22	.194 [4.93]	.100 [2.54]	.100 [2.54]	.100 [2.54]
-03, -23	.394 [10.01]	.300 [7.62]	.300 [7.62]	N/A
-04, -24	.584 [14.83]	.490 [12.45]	N/A	N/A
-06	.124 [3.15]	N/A	N/A	N/A

ROW OPTION	BODY
-S	SSW-XX-S
-D	SSW-XX-D
-D-N	NSW-XX-D-N-XX
-T	SSW-XX-T
-P	SSW-XX-P
-Q	SSW-XX-T

SSW-1XX-XX-XXX-X-XX-XXX-XX

No OF POSITIONS
-01 THRU -50
(-P OPTION: 36 POS MAX)

LEAD STYLE
(SEE TABLE 1)
-01 THRU -06 (STD. INS. FORCE)
-21 THRU -24 (LOW INS. FORCE)

OPTION
-LL: LOCKING LEAD
(SEE FIG 4, SHEET 2)
(N/A IN SINGLE ROW,
1 & 2 POSITION)

POLARIZING OPTION
INDICATE POS, SEE FIG 3, SHEET 2

PLATING SPECIFICATION

BS -G: 20μ" GOLD IN CONTACT AREA,
3μ" GOLD ON TAIL
-T: MATTE TIN CONTACT AND TAIL
-S: 30μ" SELECTIVE GOLD IN CONTACT AREA,
MATTE TIN ON TAIL
-H: 30μ" HEAVY GOLD IN CONTACT AREA,
3μ" GOLD ON TAIL
-E: 50μ" EXTRA HEAVY GOLD IN CONTACT AREA,
3μ" GOLD ON TAIL
-F: 3μ" FLASH SELECTIVE GOLD IN CONTACT AREA,
MATTE TIN ON TAIL
-STL: 30μ" SELECTIVE GOLD IN CONTACT AREA,
TIN/LEAD (90/10 ± 5%) TAIL
-TL: TIN/LEAD (90/10 ± 5%) CONTACT AND TAIL
(AVAILABLE ONLY ON LEAD STYLES -01)
-TM: MATTE TIN CONTACT AND TAIL (CONTACT -21 THRU -24 N/A)
-SM: 30μ" SELECTIVE GOLD IN CONTACT AREA,
MATTE TIN ON TAIL
-FM: 3μ" FLASH GOLD SELECTIVE IN CONTACT AREA,
MATTE TIN ON TAIL
-L: 10μ" LIGHT SELECTIVE GOLD IN CONTACT AREA,
MATTE TIN ON TAIL

OPTION
-RA: RIGHT ANGLE (SEE FIG 2, SHEET 2)
(STYLE -01 & -21 N/A)
-N: NOTCH (SEE FIG 6, SHEET 3)
(ONLY AVAILABLE IN -D ROW)
(ONLY AVAILABLE IN 5, 7, 8, 10, 12,
13, 15, 17, 20, 25, 32, 36 POSITIONS)
(USE NSW-XX-D-N-XX BODY,
SEE TABLE 6)

ROW SPECIFICATION
-S: SINGLE
-D: DOUBLE
-T: TRIPLE
-P: SINGLE
-Q: TRIPLE WITH ONLY OUTER 2 ROWS
FILLED

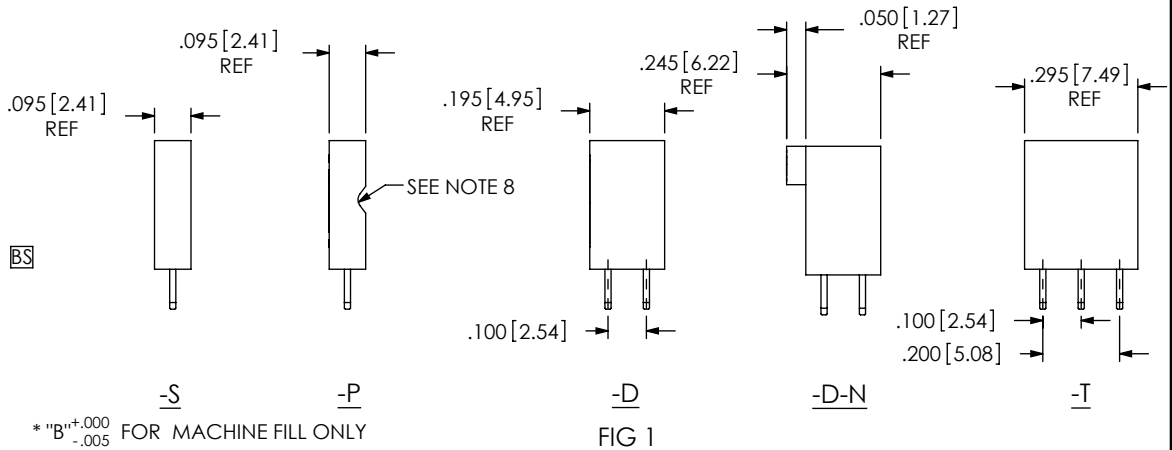
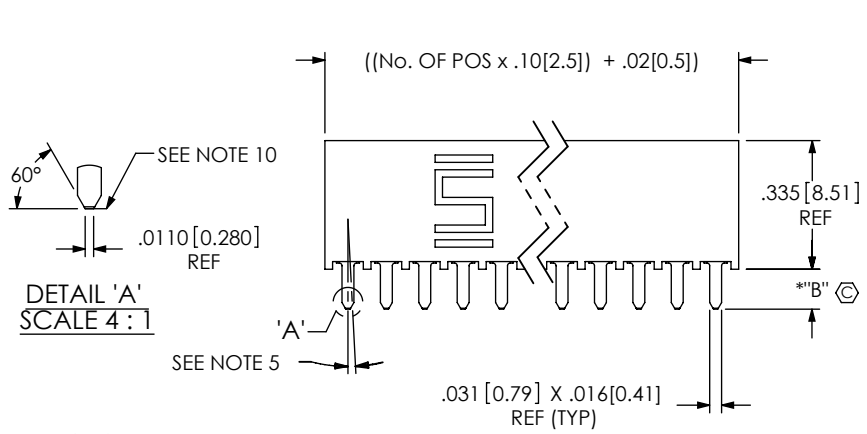

- NOTES:
- ⊙ REPRESENTS A CRITICAL DIMENSION.
 - MAXIMUM CUT FLASH: .015[.38] WITH NO FLASH BELOW STANDOFFS OR IN CONTACT HOLES.
 - MINIMUM CONTACT PUSHOUT FORCE: 1.5 LBS.
 - MAXIMUM ALLOWABLE BOW: .003[.08] INCH/INCH.
 - MAXIMUM ALLOWABLE SWAY: 2° (TYP) FOR HAND FILL & 1° (TYP) FOR MACHINE FILL.
 - MAXIMUM ALLOWABLE VARIATION BETWEEN ROWS: .010[.25].
 - "END WALLS" AFTER CUTTING SHOULD BE .020±.003 [.51±.08].
 - NOTCH ON -P-RA & -D-RA-N OPTIONS TO BE ORIENTED AS SHOWN.
 - SHEAR LOCATION TO BE WITHIN .001[.03] OF THE BREAK OFF CENTER LOCATION.
 - SHEAR LOCATION TO BE WITHIN .001[.03] OF THE BREAK OFF CENTER LOCATION FOR MACHINE FILL.
 - LEAD STYLE X2 (SINGLE AND DOUBLE) -RA'S TO BE LAYER PACKAGED. ALL OTHER -RA LEAD STYLES: UNDER 5 POSITION TO BE LAYER PACKAGED, 5 AND UP TO BE PACKAGED IN TUBES.

UNLESS OTHERWISE SPECIFIED, DIMENSIONS ARE IN INCHES.

TOLERANCES ARE:
DECIMALS ANGLES
.XX: ±.01 [.3]
.XXX: ±.005 [.13]

PROPRIETARY NOTE
THIS DOCUMENT CONTAINS INFORMATION CONFIDENTIAL AND PROPRIETARY TO SAMTEC, INC. AND SHALL NOT BE REPRODUCED OR TRANSFERRED TO OTHER DOCUMENTS OR DISCLOSED TO OTHERS OR USED FOR ANY PURPOSE OTHER THAN THAT WHICH IT WAS OBTAINED WITHOUT THE EXPRESSED WRITTEN CONSENT OF SAMTEC, INC.

MATERIAL: DO NOT SCALE DRAWING SHEET SCALE: 2:1
-S, -D, -D-N: VECTRA E130I, COLOR: BLACK UL94 V0
-P, -T: PCT, COLOR: BLACK UL94 V0
CONTACT: PHOSPHOR BRONZE, SPRING TEMPER ALLOY S11 OR S10
(TENSILE STRENGTH 90-100 KSI)
(YIELD STRENGTH @ 2% OFFSET 88-98 KSI)
PER MIL-B-13501
THICKNESS: .0160±.001 [0.635±0.03]

520 PARK EAST BLVD, NEW ALBANY, IN 47150
PHONE: 812-944-6733 FAX: 812-948-5047
e-Mail: info@SAMTEC.com code 55322

DESCRIPTION:
ASSEMBLY, SOCKET STRIP .016 X .031 TAIL

DWG. NO.
SSW-1XX-XX-XXX-X-XX-XXX-XX

BY: PURVIS 06/12/1987 SHEET 1 OF 3

TABLE 3			
IN-PROCESS	"D"	"E"	"F"
SSW-1XX-X2-X-D-RA	.194 [4.93]	.394 [10.01]	-----
SSW-1XX-03-X-D-RA	.394 [10.01]	.594 [15.09]	-----
SSW-1XX-02-X-T-RA	.194 [4.93]	.394 [10.01]	.594 [15.09]

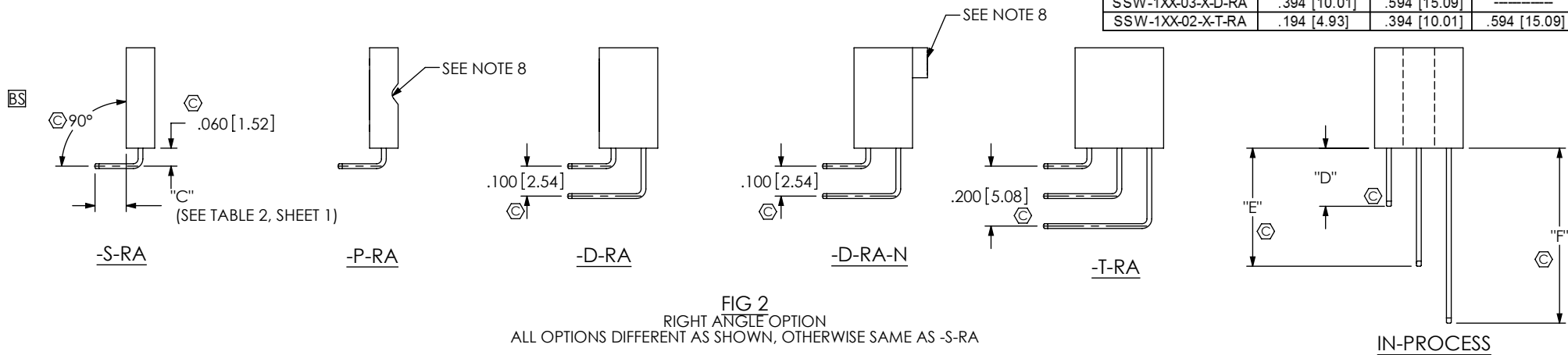

FIG 2
RIGHT ANGLE OPTION
ALL OPTIONS DIFFERENT AS SHOWN, OTHERWISE SAME AS -S-RA

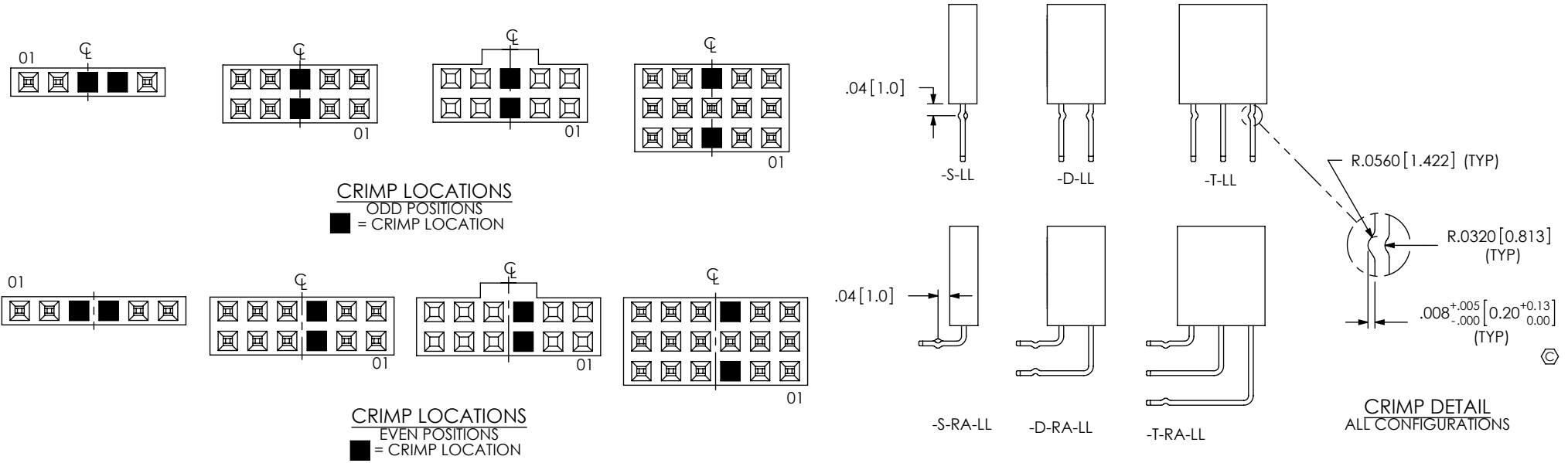

FIG 4
LOCKING LEAD OPTION
ALL OPTIONS SAME AS -S-XX-LL
UNLESS OTHERWISE SHOWN

PROPRIETARY NOTE
THIS DOCUMENT CONTAINS INFORMATION CONFIDENTIAL AND PROPRIETARY TO SAMTEC, INC. AND SHALL NOT BE REPRODUCED OR TRANSFERRED TO OTHER DOCUMENTS OR DISCLOSED TO OTHERS OR USED FOR ANY PURPOSE OTHER THAN THAT WHICH IT WAS OBTAINED WITHOUT THE EXPRESSED WRITTEN CONSENT OF SAMTEC, INC.

DO NOT SCALE DRAWING

SHEET SCALE: 2:1



520 PARK EAST BLVD. NEW ALBANY, IN 47150
PHONE: 812-944-6733 FAX: 812-948-5047
e-Mail info@SAMTEC.com code 55322

DESCRIPTION:
ASSEMBLY, SOCKET STRIP .016 X .031 TAIL

DWG. NO.
SSW-1XX-XX-XXX-X-XX-XXX-XX

BY: PURVIS 06/12/1987 SHEET 2 OF 3

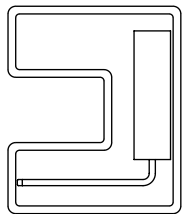

SSW-1XX-03-XXX-S-RA
SSW-1XX-23-XXX-S-RA

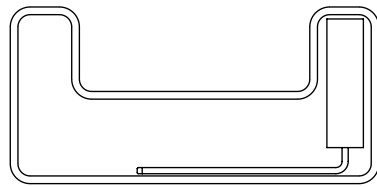

SSW-1XX-04-XXX-S-RA
SSW-1XX-24-XXX-S-RA

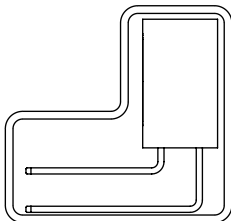

SSW-1XX-03-XXX-D-RA
SSW-1XX-23-XXX-D-RA

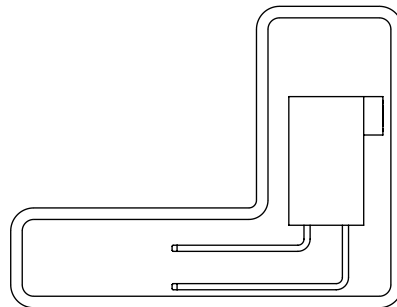

SSW-1XX-03-XXX-D-RA-N
SSW-1XX-23-XXX-D-RA-N

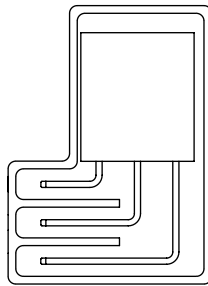

SSW-1XX-02-XXX-T-RA
SSW-1XX-02-XXX-Q-RA

FIG 5
PACKAGING VIEWS
(SEE NOTE 11)

BS

TABLE 5 TUBE SPECIFICATION		
PART NUMBER	TUBE	PLUG
SSW-1XX-03-XXX-S-RA SSW-1XX-23-XXX-S-RA	PT-3-24-01-01	TP-03
SSW-1XX-04-XXX-S-RA SSW-1XX-24-XXX-S-RA	PT-1-24-01-34	TP-03
SSW-1XX-03-XXX-D-RA SSW-1XX-23-XXX-D-RA	PT-1-24-06-40	TP-07
SSW-1XX-03-XXX-D-RA-N SSW-1XX-23-XXX-D-RA-N	ASP-90341-01-S	TP-07
SSW-1XX-02-XXX-T-RA SSW-1XX-02-XXX-Q-RA	PT-1-24-04-40	TP-07

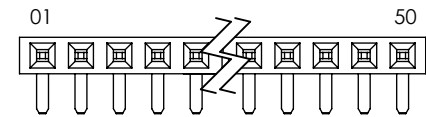

-S, -P, -S-RA & -P-RA

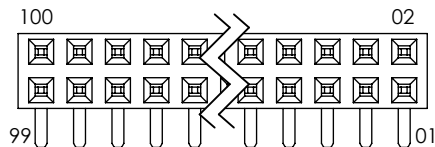

-D, -D-RA

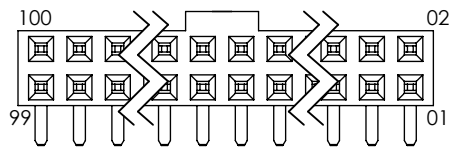

-D-N, -D-RA-N

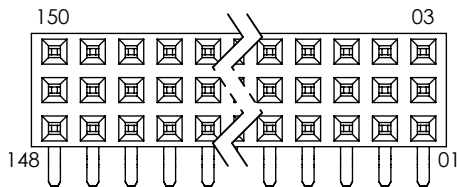

-T, -Q, -T-RA & -Q-RA

FIG 3
POLARIZATION LOCATION
(INSERT PK-06-N INTO SPECIFIED POSITION & BREAK OFF TAB)
(-RA OPTION SHOWN FOR ORIENTATION PURPOSE ONLY)

TABLE 6	
POS PER ROW	NSW-XX-D-N-XX
5	NSW-47-D-N-05
7	NSW-47-D-N-07
8	NSW-44-D-N-08
10	NSW-43-D-N-10
12	NSW-38-D-N-12
13	NSW-41-D-N-13
15	NSW-47-D-N-15
17	NSW-35-D-N-17
20	NSW-20-D-N
25	NSW-25-D-N
32	NSW-32-D-N
36	NSW-36-D-N

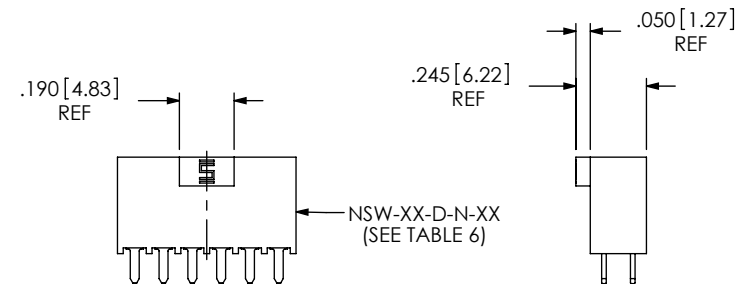

FIG 6
NOTCH OPTION
DIFFERENT AS SHOWN, OTHERWISE SAME AS FIG 1

PROPRIETARY NOTE
THIS DOCUMENT CONTAINS INFORMATION
CONFIDENTIAL AND PROPRIETARY TO
SAMTEC, INC. AND SHALL NOT BE REPRODUCED
OR TRANSFERRED TO OTHER DOCUMENTS OR
DISCLOSED TO OTHERS OR USED FOR ANY
PURPOSE OTHER THAN THAT WHICH IT WAS
OBTAINED WITHOUT THE EXPRESSED WRITTEN
CONSENT OF SAMTEC, INC.

DO NOT SCALE DRAWING

SHEET SCALE: 2:1



520 PARK EAST BLVD, NEW ALBANY, IN 47150
PHONE: 812-944-6733 FAX: 812-948-5047
e-Mail info@SAMTEC.com code 55322

DESCRIPTION:
ASSEMBLY, SOCKET STRIP .016 X .031 TAIL

DWG. NO.
SSW-1XX-XX-XXX-X-XX-XXX-XX

BY: PURVIS 06/12/1987 SHEET 3 OF 3