

Features

- 64K x 18 Organization
- 0.5 μ CMOS Technology
- Synchronous Burst Mode of Operation Compatible with i486™ and Pentium™ Processors
- Supports Pentium™ Processor Address Pipelining
- Common I/O and Registered Outputs
- Single +3.3V \pm 5% Power Supply and Ground
- LVTTTL I/O Compatible
- Fast \overline{OE} time: 5ns
- Registered Addresses, Data Ins, Control signals, and Outputs
- Asynchronous Output Enable
- Self-Timed Write Operation and Byte Write Capability
- Low Power Dissipation
 - 1.1 W Active at 83 MHz
 - 90 mW Standby
- 52 Lead PLCC Package
- 5V Tolerant I/O

Description

IBM Microelectronics 1M SRAM is a Synchronous Burstable Pipelined, high performance CMOS Static RAM that is versatile, wide I/O, and achieves 5 nsec access and 12nsec cycle time. A single clock is used to initiate the read/write operation and all internal operations are self-timed. At the rising edge of the Clock, all Addresses, Data Ins and Control Signals are registered internally. Burst mode operation, compatible with the i486™ and Pentium™ Processor's sequence, is accomplished by integrating input

registers, internal 2-bit burst counter and high speed SRAM in a single chip. Burst reads are initiated with either \overline{ADSP} or \overline{ADSC} being LOW with a valid address during the rising edge of clock. Data from this address plus the three subsequent addresses will be output. The chip is operated with a single +3.3 V power supply and is compatible with LVTTTL I/O interfaces.

Pin Description

A0-A15	Address input
DQ0-DQ17	Data Input/Output (0-8,9-17)
CLK	Clock
\overline{WEa}	Write Enable, Byte a (0 to 8)
\overline{WEb}	Write Enable, Byte b (9 to 17)
\overline{OE}	Output Enable
\overline{ADSP}	Address Status Processor
\overline{ADSC}	Address status controller
\overline{ADV}	Burst Advance Control
\overline{CS}	\overline{ADSP} Gated Chip Select
V _{DD}	Power Supply (+3.3V)
V _{SS}	Ground

X18 PLCC Pin Array Layout

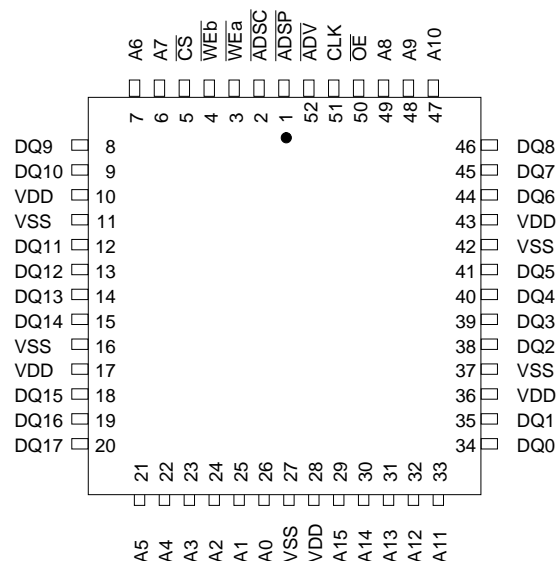

Block Diagram

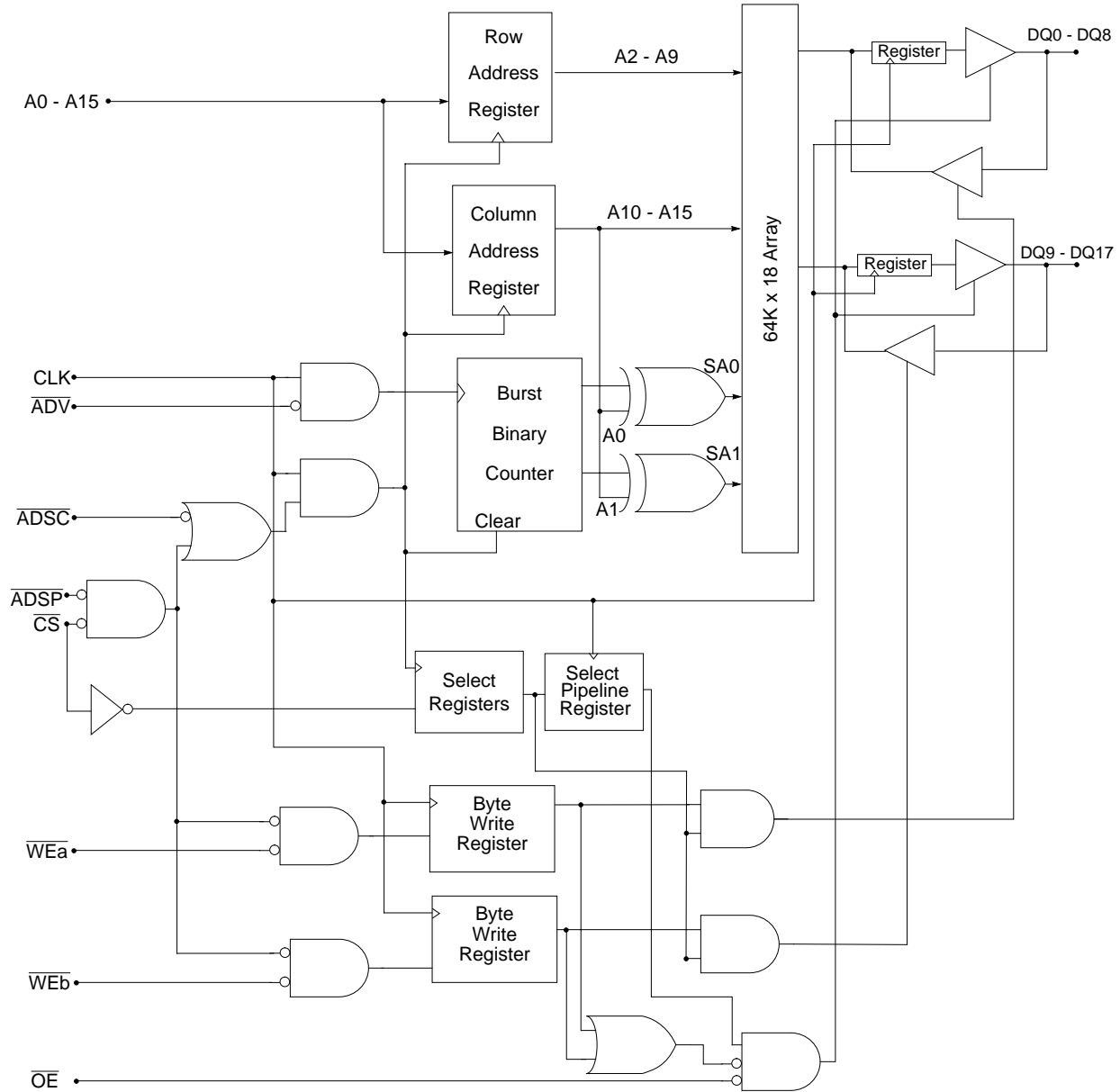

Ordering Information

Part Number	Organization	Speed	Leads	Notes
IBM041813PPLB-12	64K x 18	5 ns Access / 12 ns Cycle	52 Pin PLCC	

Burst SRAM Clock Truth Table

CLK	\overline{CS}	\overline{ADSP}	\overline{ADSC}	\overline{ADV}	\overline{WE}	\overline{OE}	DQ	Operation
L→H	H	X	L	X	X	X	High-Z	Deselected Cycle
L→H	L	L	X	X	X	L	Q	Read from External Address, Begin Burst
L→H	L	L	X	X	X	H	High-Z	Read from External Address, Begin Burst
L→H	L	H	L	X	H	L	Q	Read from External Address, Begin Burst
L→H	L	H	L	X	L	X	D	Write to External Address, Begin Burst
L→H	X	H	H	L	H	L	Q	Read from next Add., Continue Burst
L→H	X	H	H	L	L	X	D	Write to next Add., Continue Burst
L→H	X	H	H	H	H	L	Q	Read from Current Add., Suspend Burst
L→H	X	H	H	H	L	X	D	Write to Current Add., Suspend Burst
L→H	H	X	H	L	H	L	Q	Read from next Add., Continue Burst
L→H	H	X	H	L	L	X	D	Write to next Add., Continue Burst
L→H	H	X	H	H	H	L	Q	Read from current Add., Suspend Burst

- For a write operation preceded by a read cycle, \overline{OE} must be HIGH early enough to allow Input Data Setup, and must be kept HIGH through Input Data Hold Time.
- \overline{WE} refers to \overline{WEa} , \overline{WEb} .
- \overline{ADSP} is gated by \overline{CS} , and \overline{CS} is used to block \overline{ADSP} when $\overline{CS} = V_{IH}$, as required in applications using Processor Address Pipelining.
- All Addresses, Data In and Control signals are registered on the rising edge of CLK.
- Write cycles will put the bus into High-Z on the first rising clock edge according to the T_{CHZ} timing. Deselect cycles will put the bus into High-Z on the second rising edge of clock according to the T_{CHZ} timing. If a deselect cycle occurs and \overline{WE} is enabled within the same cycle, the part behaves as though it was in a deselect cycle.

Burst Sequence Truth Table

External Address	A15-A2	(A1,A0)				Notes
		(0,0)	(0,1)	(1,0)	(1,1)	
1st Access	A15-A2	(0,0)	(0,1)	(1,0)	(1,1)	
2nd Access	A15-A2	(0,1)	(0,0)	(1,1)	(1,0)	
3rd Access	A15-A2	(1,0)	(1,1)	(0,0)	(0,1)	
4th Access	A15-A2	(1,1)	(1,0)	(0,1)	(0,0)	

Write Enable Truth Table

\overline{WEa}	\overline{WEb}	Byte Written	Notes
H	H	Read All Bytes	
L	L	Write All Bytes	
L	H	Write Byte A ($D_{IN} 0 - 8$)	
H	L	Write Byte B ($D_{IN} 9 - 17$)	

Absolute Maximum Ratings

Parameter	Symbol	Rating	Units	Notes
Power Supply Voltage	V_{DD}	-0.5 to 4.6	V	1
Input Voltage	V_{IN}	-0.5 to 6.0	V	1
Output Voltage	V_{OUT}	-0.5 to $V_{DD}+0.5$	V	1
Operating Temperature	T_{OPR}	0 to +70	°C	1
Storage Temperature	T_{STG}	-55 to +125	°C	1
Power Dissipation	P_D	1.5	W	1
Short Circuit Output Current	I_{OUT}	50	mA	1

1. Stresses greater than those listed under "Absolute Maximum Ratings" may cause permanent damage to the device. This is a stress rating only and functional operation of the device at these or any other conditions above those indicated in the operational sections of this specification is not implied. Exposure to absolute maximum rating conditions for extended periods may affect reliability.

Recommended DC Operating Conditions ($T_A=0$ to 70°C)

Parameter	Symbol	Min.	Typ.	Max.	Units	Notes
Supply Voltage	V_{DD}	3.135	3.3	3.465	V	1, 4
Input High Voltage	V_{IH}	2.2	—	5.5	V	1, 2, 4
Input Low Voltage	V_{IL}	-0.3	—	0.8	V	1, 3, 4
Output Current	I_{OUT}	—	5	8	mA	4

1. All voltages referenced to V_{SS} . All V_{DD} and V_{SS} pins must be connected.
2. $V_{IH}(\text{Max})\text{DC} = 5.5$ V, $V_{IH}(\text{Max})\text{AC} = 6.0$ V (pulse width ≤ 4.0 ns).
3. $V_{IL}(\text{Min})\text{DC} = -0.3$ V, $V_{IL}(\text{Min})\text{AC} = -1.5$ V (pulse width ≤ 4.0 ns).
4. Input Voltage levels are tested to the following DC conditions: 1 microsecond cycle and 200 nanosecond set-up and hold times.

Capacitance ($T_A=0$ to $+70^\circ\text{C}$, $V_{DD}=3.3\text{V} \pm 5\%$, $f=1\text{MHz}$)

Parameter	Symbol	Test Condition	Max	Units	Notes
Input Capacitance	C_{IN}	$V_{IN} = 0\text{V}$	5	pF	
Data I/O Capacitance (DQ0-DQ17)	C_{OUT}	$V_{OUT} = 0\text{V}$	5	pF	

DC Electrical Characteristics ($T_A=0$ to $+70^\circ\text{C}$, $V_{DD}=3.3\text{V} \pm 5\%$)

Parameter	Symbol	Min.	Max.	Units	Notes
Operating Current Average Power Supply Operating Current ($I_{OUT} = 0$, $OE = V_{IH}$)	I_{DD12}	—	325	mA	2, 3
Standby Current Power Supply Standby Current ($CS = V_{IH}$, All other inputs = V_{IH} or V_{IL} , $I_{OUT} = 0$, CLK at 100MHz)	I_{SB}	—	25	mA	1, 3
Input Leakage Current Input Leakage Current, any input ($V_{IN} = 0$ & V_{DD})	I_{LI}	—	+1	μA	4
Output Leakage Current ($V_{OUT} = 0$ & V_{DD} , $OE = V_{IH}$)	I_{LO}	—	+1	μA	
Output High Level Output "H" Level Voltage ($I_{OH} = -8\text{mA}$ @ 2.4V)	V_{OH}	2.4	—	V	
Output Low Level Output "L" Level Voltage ($I_{OL} = +8\text{mA}$ @ 0.4V)	V_{OL}	—	0.4	V	
1. I_{SB} = Stand-by Current. 2. I_{DD} = Selected Current. 3. I_{OUT} = Chip Output Current. 4. The input leakage current for 5.5V inputs is 200 μA for Clk, Chip Selects, and Output Enable. Other inputs have 100 μA of leakage current at 5.5V.					

AC Test Conditions ($T_A=0$ to $+70^\circ\text{C}$, $V_{DD}=3.3\text{V} \pm 5\%$)

Parameter	Symbol	Conditions	Units	Notes
Input Pulse High Level	V_{IH}	3.0	V	
Input Pulse Low Level	V_{IL}	0	V	
Input Rise Time	T_R	2.0	ns	
Input Fall Time	T_F	2.0	ns	
Input and Output Timing Reference Level		1.5	V	
Output Load Conditions				1
1. See AC Test Loading figure 1 on page 7.				

AC Characteristics ($T_A=0$ to $+70^\circ\text{C}$, $V_{DD}=3.3\text{V} \pm 5\%$, Units in nsec)

Parameter	Symbol	-12		Notes
		Min.	Max.	
Cycle Time	t_{CYCLE}	12.0	—	
Clock Pulse High	t_{CH}	3.0	—	
Clock Pulse Low	t_{CL}	3.0	—	
Clock to Output Valid	t_{CQ}	—	5.0	1
Address Status Controller Setup Time	t_{ADSCS}	2.5	—	
Address Status Controller Hold Time	t_{ADSCH}	0.5	—	
Address Status Processor Setup Time	t_{ADSPS}	2.5	—	
Address Status Processor Hold Time	t_{ADSPH}	0.5	—	
Advance Setup Time	t_{ADVS}	2.5	—	
Advance Hold Time	t_{ADVH}	0.5	—	
Address Setup Time	t_{AS}	2.5	—	
Address Hold Time	t_{AH}	0.5	—	
Chip Selects Setup Time	t_{CSS}	2.5	—	
Chip Selects Hold Time	t_{CSH}	0.5	—	
Write Enables Setup Time	t_{WES}	2.5	—	
Write Enables Hold Time	t_{WEH}	0.5	—	
Data In Setup Time	t_{DS}	2.5	—	
Data In Hold Time	t_{DH}	0.5	—	
Data Out Hold Time	t_{CQX}	0.75	—	1
Clock High to Output High-Z	t_{CHZ}	—	5.5	1, 2, 3
Clock High to Output Active	t_{CLZ}	0.5	—	1, 2, 3
Output Enable to High-Z	t_{OHZ}	2.0	6.5	1, 2
Output Enable to Low-Z	t_{OLZ}	0.25	—	1, 2
Output Enable to Output Valid	t_{OQ}	—	5.0	

1. See AC Test Loading figure 1 on page 7.
2. T_{OHZ} , T_{OLZ} , T_{CHZ} and T_{CLZ} transitions are measured ± 200 mV from steady state voltage. See AC Test Loading figure 2 on page 7.
3. In depth expansion applications where one SRAM is selected and the other is not, bus contention will not occur because T_{CLZ} is measured from the second rising clock edge while T_{CHZ} is measured from the first rising clock edge.

AC Test Loading

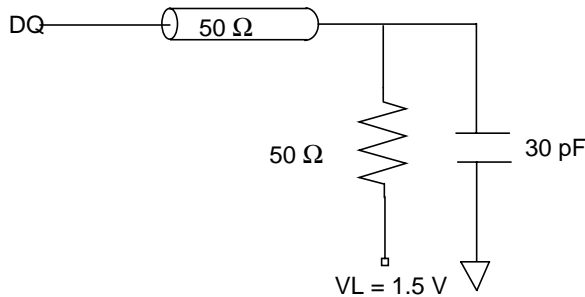

Fig. 1 Test Equivalent Load

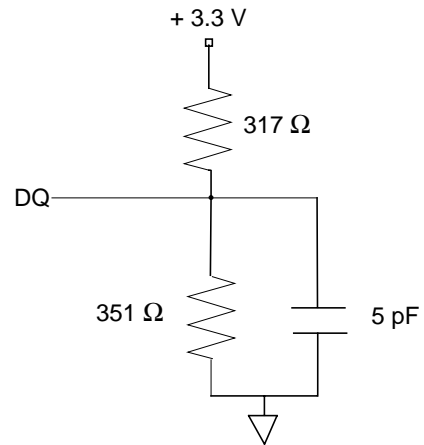
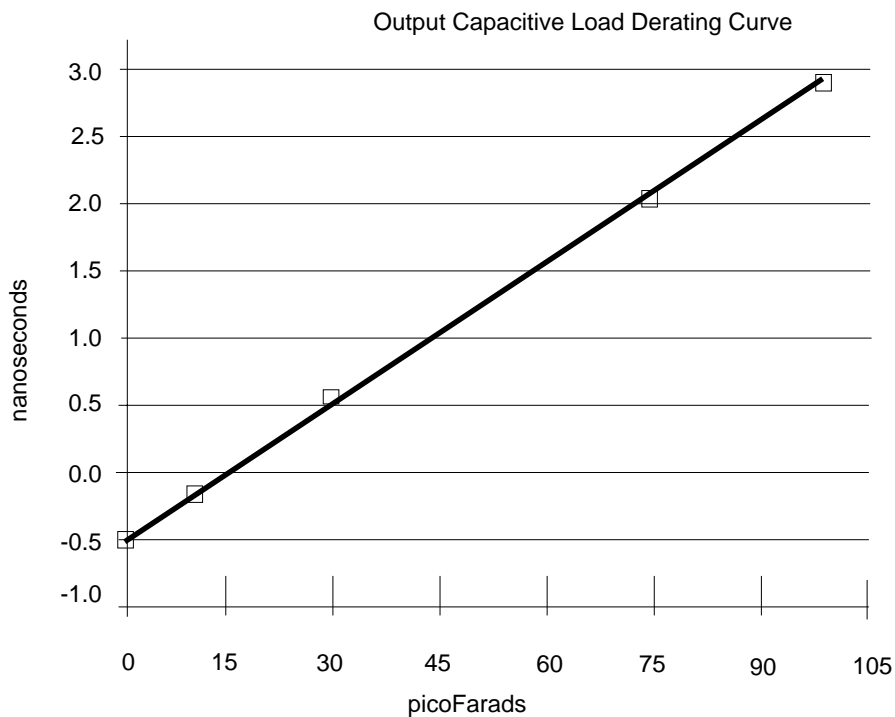
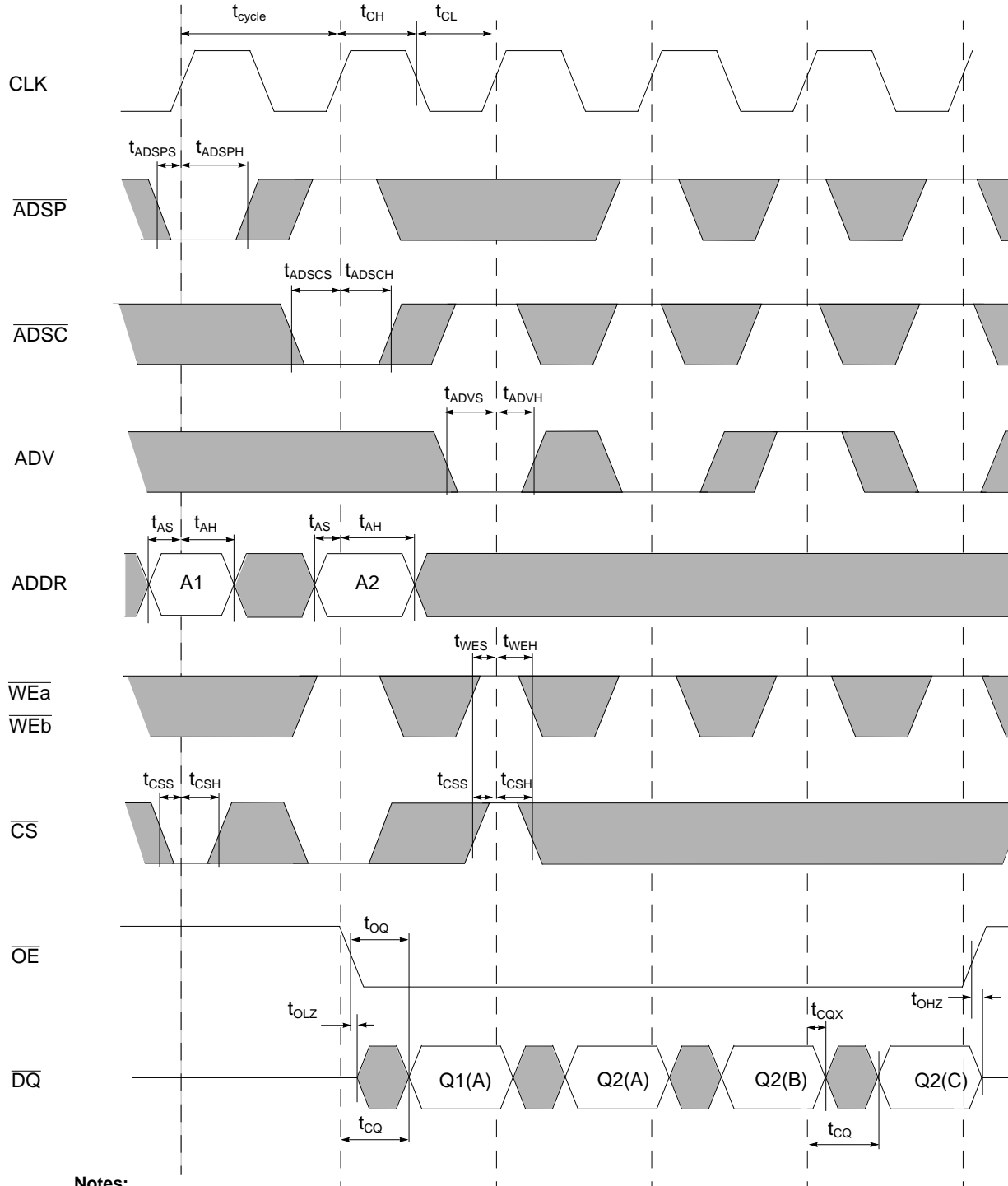

Fig. 2 Test Equivalent Load



The derating curve above is for a purely capacitive load on the output driver. For example, a part specified at 5ns access time will behave as though it has an 5.5 ns access time if a 30 pF load with no DC component was attached to the output driver. The access times guaranteed in the datasheets are based on a 50 ohm terminated test load. For unterminated loads the derating curve should be used. This curve is based on nominal process conditions with worst case parameters $V_{DD} = 3.14 \text{ V}$, $T_A = 70^\circ \text{ C}$.

Timing Diagram (Burst Read)



Notes:

1. Q1(A) and Q2(A) refer to output for Address A1 and A2 respectively.
2. Q2(B) and Q2(C) refer to output from subsequent internal burst counter addresses.

Timing Diagram (Burst Write)

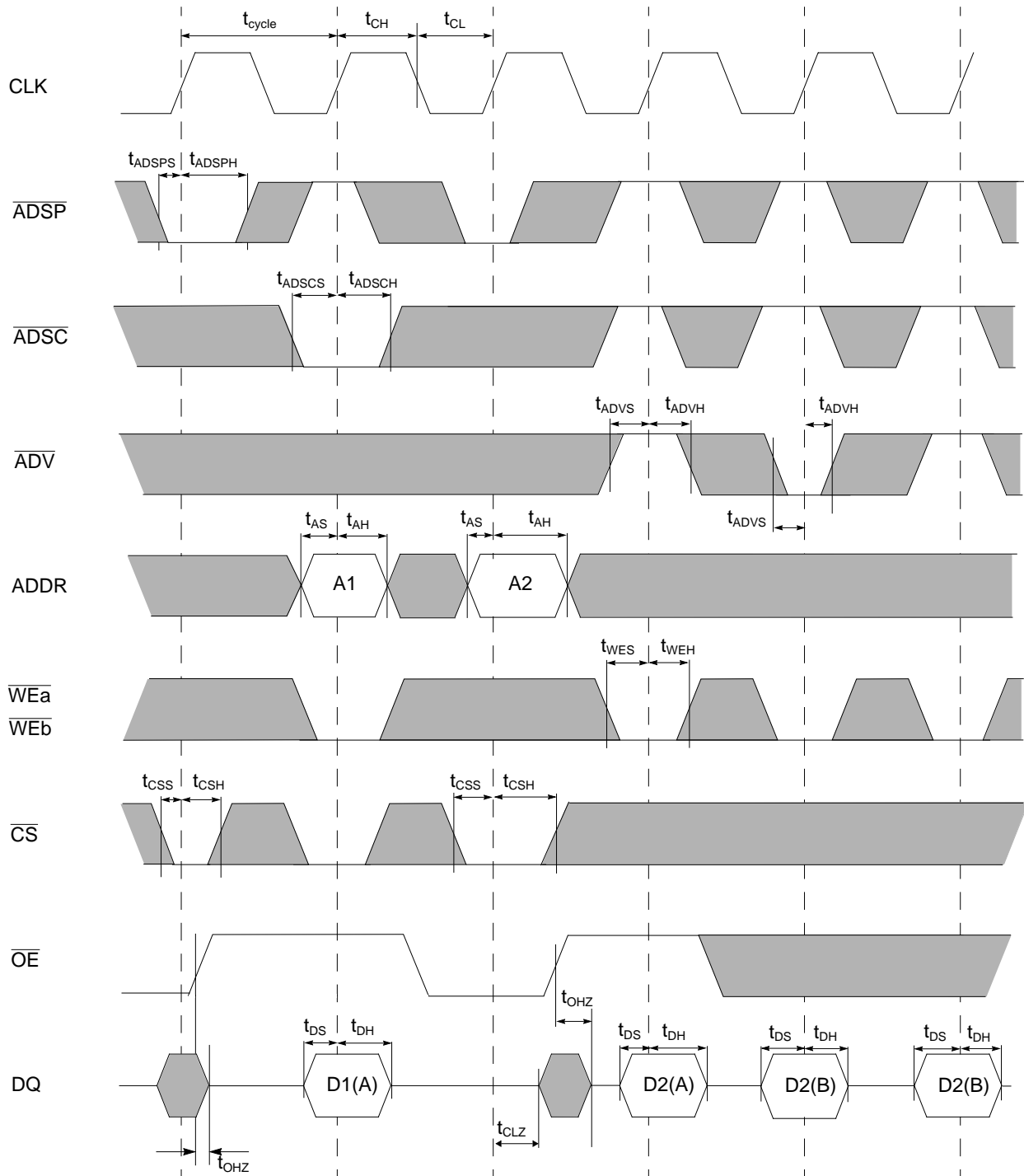

Notes:

1. D1(A) and D2(A) refer to data written to addresses A1 and A2.
2. D2(B) refers to data written to a subsequent internal burst counter address.
3. \overline{WEa} and \overline{WEb} are Don't Cares when \overline{ADSP} is sampled LOW.

52 Pin PLCC Package Diagram

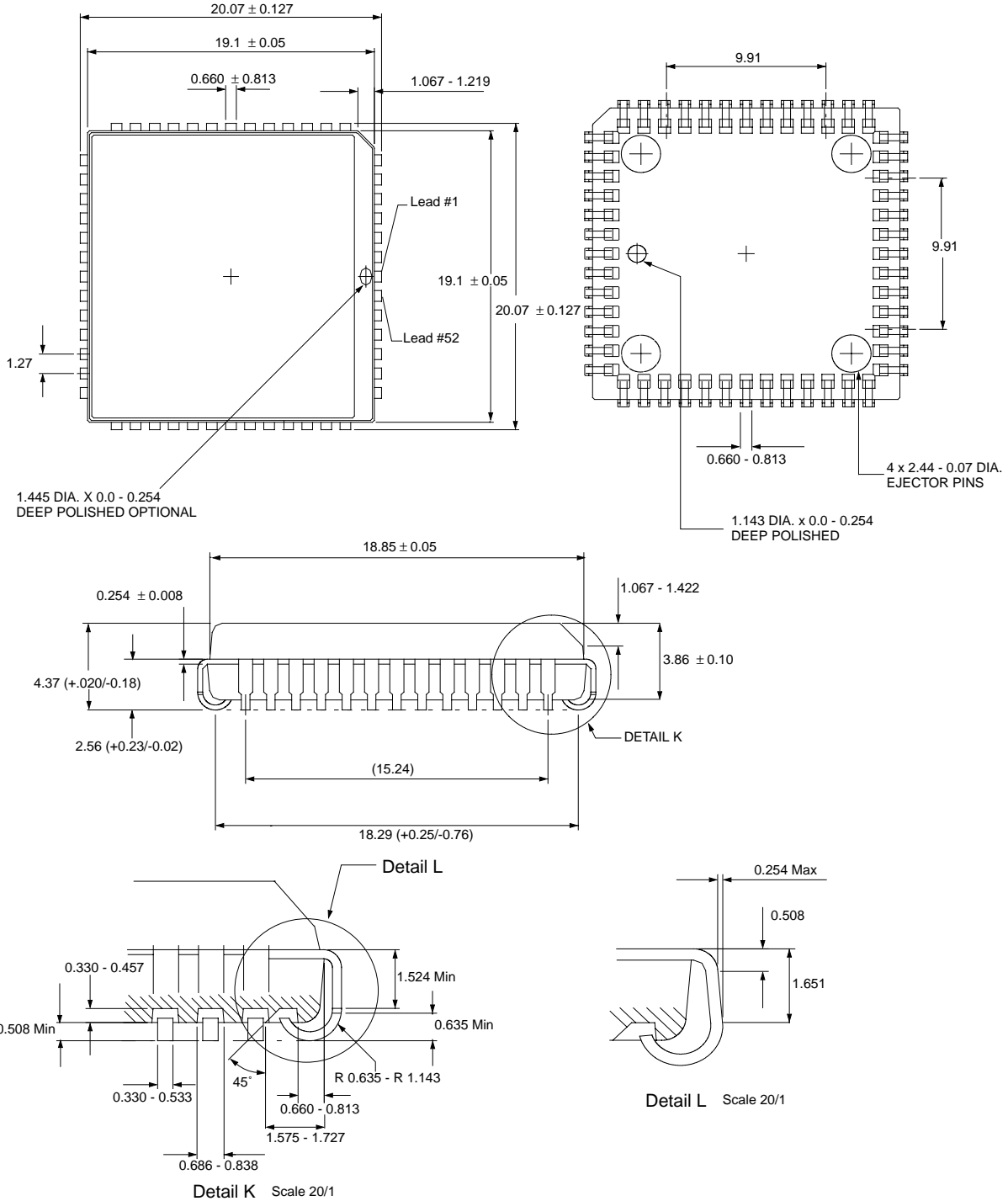

Note: All measurements in millimeters

Revision Log

Rev	Contents of Modification
5/94	Initial Release of the 64K x 18 (10/12) TQFP BURST MODE Application Spec.
3/95	Updated -10, -12 Specifications.
7/95	Added Note 5 on Burst SRAM Clock Truth Table & Note 3 on AC Characteristics for clarification purposes. Updated AC Characteristics as well. Removed Preliminary classification.
3/96	Removed -10 specification.
9/97	Updated Part numbers to add die revision character. This new datasheet DOES NOT reflect a die revision



© International Business Machines Corp.1997

Printed in the United States of America
All rights reserved

IBM and the IBM logo are registered trademarks of the IBM Corporation.

This document may contain preliminary information and is subject to change by IBM without notice. IBM assumes no responsibility or liability for any use of the information contained herein. Nothing in this document shall operate as an express or implied license or indemnity under the intellectual property rights of IBM or third parties. The products described in this document are not intended for use in implantation or other direct life support applications where malfunction may result in direct physical harm or injury to persons. **NO WARRANTIES OF ANY KIND, INCLUDING, BUT NOT LIMITED TO, THE IMPLIED WARRANTIES OF MERCHANTABILITY OR FITNESS FOR A PARTICULAR PURPOSE, ARE OFFERED IN THIS DOCUMENT.**

For more information contact your IBM Microelectronics sales representative or visit us on World Wide Web at <http://www.chips.ibm.com>

IBM Microelectronics manufacturing is ISO 9000 compliant.