

## High Current Charge Pump DC-to-DC Converter

### Features:

- Pin Compatible With TC7662/ICL7662/SI7661
- High Output Current 80 mA
- No External Diodes Required
- Wide Operating Range 3V to 18V
- Low Output Impedance 28Ω Typ.
- No Low Voltage Terminal Required
- Application Zener On-Chip
- OSC Frequency Doubling Pin Option for Smaller Output Capacitors

### Applications:

- Laptop Computers
- Disk Drives
- Process Instrumentation
- $\mu$ P-Based Controllers

### Device Selection Table

Part Number	Package	Operating Temp. Range
TC962COE	16-Pin SOIC Wide	0°C to +70°C
TC962CPA	8-Pin Plastic DIP	0°C to +70°C
TC962EPA	8-Pin Plastic DIP	-40°C to +85°C
TC962IJA	8-Pin Cerdip	-25°C to +85°C
TC962MJA	8-Pin Cerdip	-55°C to +125°C

### General Description:

The TC962 is an advanced version of the industry standard TC7662 high voltage DC-to-DC converter. Using improved design techniques and CMOS construction, the TC962 can source as much as 80 mA versus the 7662's 20 mA capability.

As an inverter, the TC962 can put out voltages as high as 18V and as low as 3V without the need for external diodes. The output impedance of the device is a low 28Ω (with the proper capacitors), voltage conversion efficiency is 99.9%, and power conversion efficiency is 97%.

The low voltage terminal (pin 6) required in some TC7662 applications has been eliminated. Grounding this terminal will double the oscillator frequency from 12 kHz to 24 kHz. This will allow the use of smaller capacitors for the same output current and ripple, in most applications. Only two external capacitors are required for inverter applications. In the event an external clock is needed to drive the TC962 (such as paralleling), driving this pin directly will cause the internal oscillator to sync to the external clock.

Pin 1, which is used as a test pin on the 7662, is a voltage reference Zener on the TC962. This Zener (6.4V at 5 mA) has a dynamic impedance of 12Ω and is intended for use where the TC962 is supplying current to external regulator circuitry and a reference is needed for the regulator circuit. (See **Section 3.0 "Applications Information" Applications Information**).

The TC962 is compatible with the LTC1044, SI7661 and ICL7662. It should be used in designs that require greater power and/or less input to output voltage drop. It offers superior performance over the ICL7660S.

### Package Type

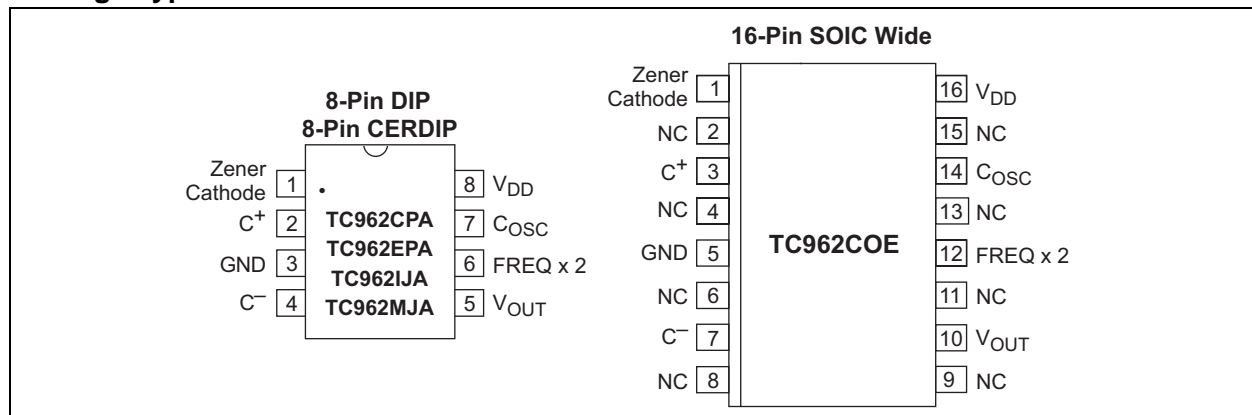

# TC962

## Functional Block Diagram

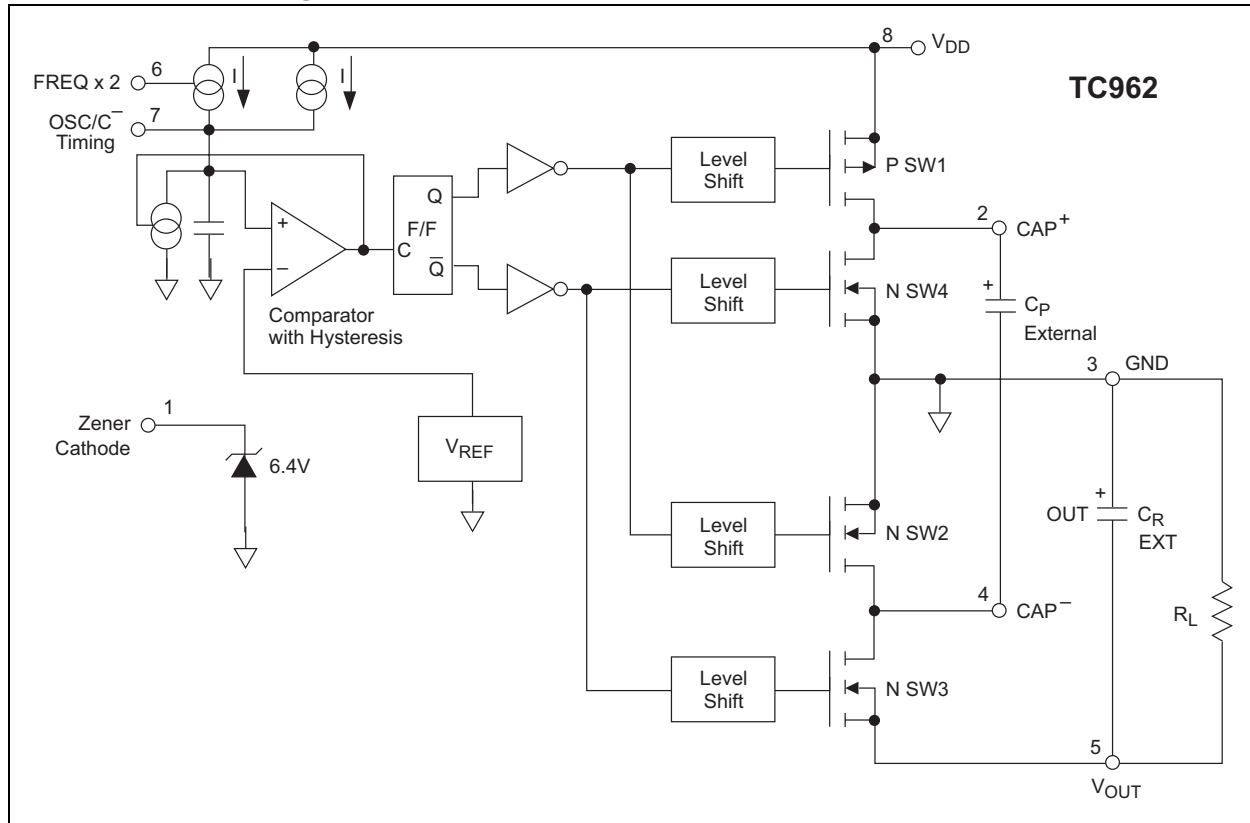

## 1.0 ELECTRICAL CHARACTERISTICS

### Absolute Maximum Ratings\*

Supply Voltage ( $V_{DD}$ to GND) .....	+18V
Input Voltage Any Pin ..... ( $V_{DD} + 0.3$ ) to ( $V_{SS} - 0.3$ ) (Note 1)	
Current Into Any Pin.....	10 mA
ESD Protection .....	$\pm 2000V$
Output Short Circuit .....	Continuous (at 5.5V Input)
Package Power Dissipation ( $T_A \leq 70^\circ C$ )	
SOIC .....	760 mW
PDIP .....	730 mW
CERDIP .....	800 mW
Package Thermal Resistance	
CERDIP, $R_{\theta J-A}$ .....	$90^\circ C/W$
PDIP, $R_{\theta J-A}$ .....	$140^\circ C/W$
Operating Temperature Range	
CPA, COE .....	$0^\circ C$ to $+70^\circ C$
IJA .....	$-25^\circ C$ to $+85^\circ C$
EPA .....	$-40^\circ C$ to $+85^\circ C$
MJA .....	$-55^\circ C$ to $+125^\circ C$
Storage Temperature Range .....	$-65^\circ C$ to $+150^\circ C$

\*Stresses above those listed under "Absolute Maximum Ratings" may cause permanent damage to the device. These are stress ratings only and functional operation of the device at these or any other conditions above those indicated in the operation sections of the specifications is not implied. Exposure to Absolute Maximum Rating conditions for extended periods may affect device reliability.

### TC962 ELECTRICAL SPECIFICATIONS

Electrical Characteristics: $V_{DD} = 15V$ , $T_A = 25^\circ C$ (See Figure ) unless otherwise noted.						
Symbol	Parameter	Min	Typ	Max	Units	Test Conditions
$V_{DD}$	Supply Voltage	3	—	18	V	
$I_S$	Supply Current $V_{DD} = 15V$  $V_{DD} = 5V$	— — — — — —	— 510 560 650 190 210 210	— 700 — — — — —	$\mu A$	$R_L = \infty$ $T_A = +25^\circ C$ $0 \leq T_A \leq +70^\circ C$ $-55^\circ C \leq T_A \leq +125^\circ C$ $T_A = +25^\circ C$ $0 \leq T_A \leq +70^\circ C$ $-55^\circ C \leq T_A \leq +125^\circ C$
$R_O$	Output Source Resistance	— — —	32 35 —	37 40 50	$\Omega$	$I_L = 20\text{ mA}$ , $V_{DD} = 15V$ $I_L = 80\text{ mA}$ , $V_{DD} = 15V$ $I_L = 3\text{ mA}$ , $V_{DD} = 5V$
$F_{OSC}$	Oscillator Frequency	— —	12 24	— —	kHz	Pin 6 Open Pin 6 GND
$P_{EFF}$	Power Efficiency	93 —	97 —	— —	%	$R_L = 2\text{ k}\Omega$
$V_{DEF}$	Voltage Efficiency	99 — 96	99.9 — —	— — —	%	$R_L = \infty$ Over temperature range
$V_Z$	Zener Voltage	6.0	6.2	6.4	V	$I_Z = 5\text{ mA}$
$Z_{ZT}$	Zener Impedance	—	12	—	$\Omega$	$I_L = 2.5\text{ mA}$ to $7.5\text{ mA}$

**Note 1:** Connecting any input terminal to voltages greater than  $V^+$  or less than GND may cause destructive latch-up. It is recommended that no inputs from sources operating from external supplies be applied prior to "power-up" of the TC962.

# TC962

## 2.0 PIN DESCRIPTIONS

The descriptions of the pins are listed in Table 2-1.

**TABLE 2-1: PIN FUNCTION TABLE**

Pin No. (8-Pin DIP) (8-Pin CERDIP)	Symbol	Description
1	Zener Cathode	Cathode of internal Zener diode.
2	C <sup>+</sup>	Positive side of external CP capacitor (pump cap).
3	GND	Ground terminal.
4	C <sup>-</sup>	Negative side of external CP capacitor (pump cap).
5	V <sub>OUT</sub>	Output voltage.
6	FREQ x 2	If grounded, frequency doubles.
7	C <sub>OSC</sub>	Capacitor to GND will decrease frequency.
8	V <sub>DD</sub>	Input voltage.

Pin No. (16-Pin SOIC)	Symbol	Description
1	Zener Cathode	Cathode of internal Zener diode.
2	NC	No connect.
3	C <sup>+</sup>	Positive side of external CP capacitor (pump cap).
4	NC	No connect.
5	GND	Ground terminal.
6	NC	No connect.
7	C <sup>-</sup>	Negative side of external CP capacitor (pump cap).
8	NC	No connect.
9	NC	No connect.
10	V <sub>OUT</sub>	Output voltage.
11	NC	No connect.
12	FREQ x 2	If grounded, frequency doubles.
13	NC	No connect.
14	C <sub>OSC</sub>	Capacitor to GND will decrease frequency.
15	NC	No connect.
16	V <sub>DD</sub>	Input voltage.

## 3.0 APPLICATIONS INFORMATION

### 3.1 Theory of Operation

The TC962 is a capacitive pump (sometimes called a switched capacitor circuit), where four MOSFET switches control the charge and discharge of a capacitor.

The functional block diagram shows how the switching action works. SW1 and SW2 are turned on simultaneously, charging  $C_P$  to the supply voltage,  $V_{IN}$ . This assumes that the on resistance of the MOSFETs in series with the capacitor results in a charging time (3 time constants) that is less than the on time provided by the oscillator frequency as shown:

$$3 (R_{DS(ON)} C_P) < C_P / (0.5 f_{OSC})$$

In the next cycle, SW1 and SW2 are turned off and after a very short interval of all switches being off (this prevents large currents from occurring due to cross conduction), SW3 and SW4 are turned on. The charge in  $C_P$  is then transferred to  $C_R$ , but with the polarity inverted. In this way, a negative voltage is now derived.

An oscillator supplies pulses to a flip-flop that is then fed to a set of level shifters. These level shifters then drive each set of switches at one-half the oscillator frequency.

The oscillator has two pins that control the frequency of oscillation. Pin 7 can have a capacitor added that is returned to ground. This will lower the frequency of the oscillator by adding capacitance to the timing capacitor internal to the TC962. Grounding pin 6 will turn on a

current source and double the frequency. This will double the charge current going into the internal capacitor, as well as any capacitor added to pin 7.

A Zener diode has been added to the TC962 for use as a reference in building external regulators. This Zener runs from pin 1 to ground.

### 3.2 Latch-Up

All CMOS structures contain a parasitic SCR. Care must be taken to prevent any input from going above or below the supply rail, or latch-up will occur. The result of latch-up is an effective short between  $V_{DD}$  and  $V_{SS}$ . Unless the power supply input has a current limit, this latch-up phenomena will result in damage to the device. (See AN763, *Latch-up Protection for MOSFET Drivers*.)

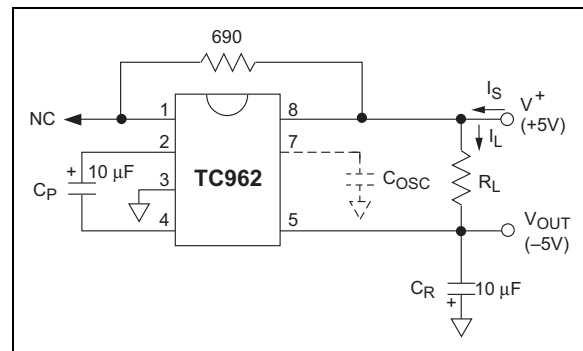

FIGURE 3-1: Test Circuit

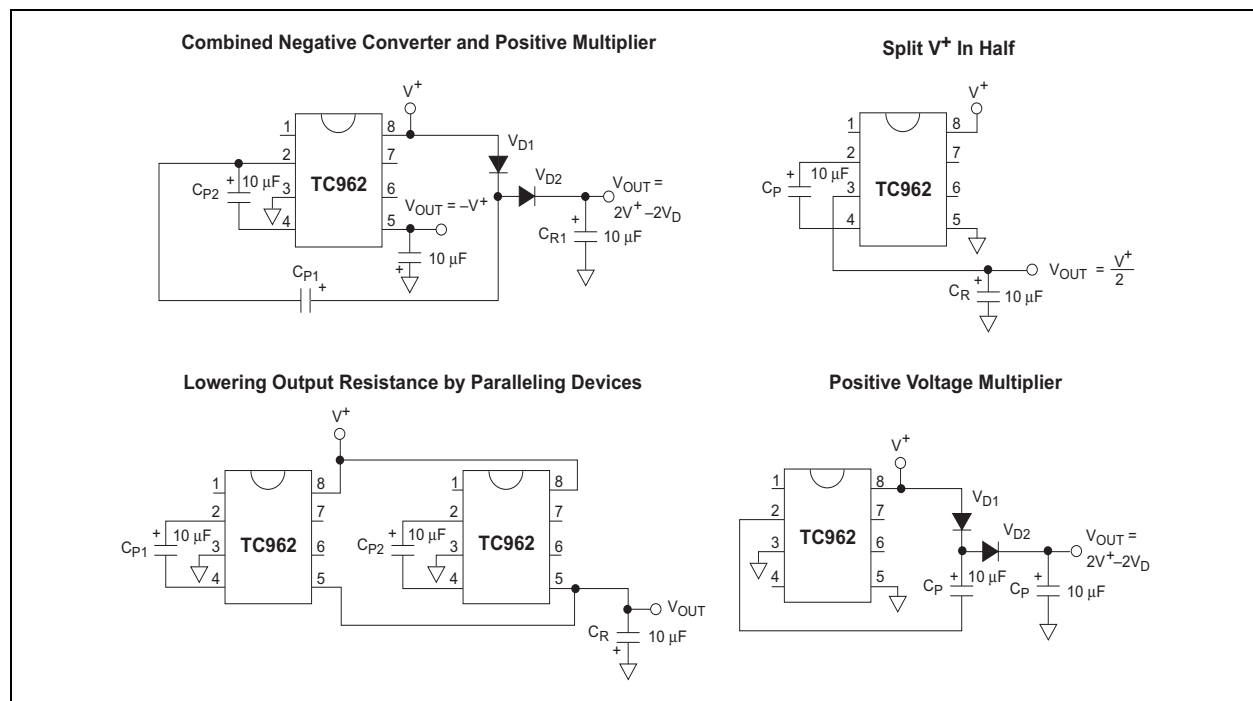

FIGURE 3-2: Typical Applications

# TC962

## 4.0 TYPICAL CHARACTERISTICS

**Note:** The graphs and tables provided following this note are a statistical summary based on a limited number of samples and are provided for informational purposes only. The performance characteristics listed herein are not tested or guaranteed. In some graphs or tables, the data presented may be outside the specified operating range (e.g., outside specified power supply range) and therefore outside the warranted range.

Circuit of Figure ,  $C_P = C_R = 10 \mu\text{F}$ ,  $C_{PESR} \approx C_{RESR} \approx 1 \Omega$ .

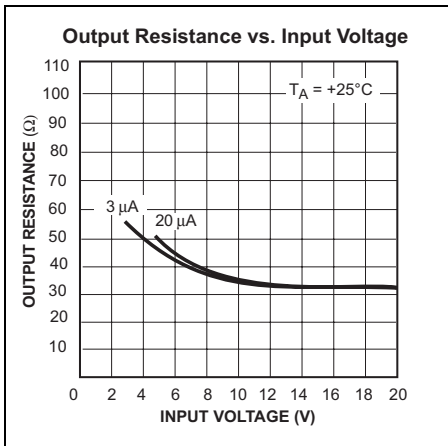
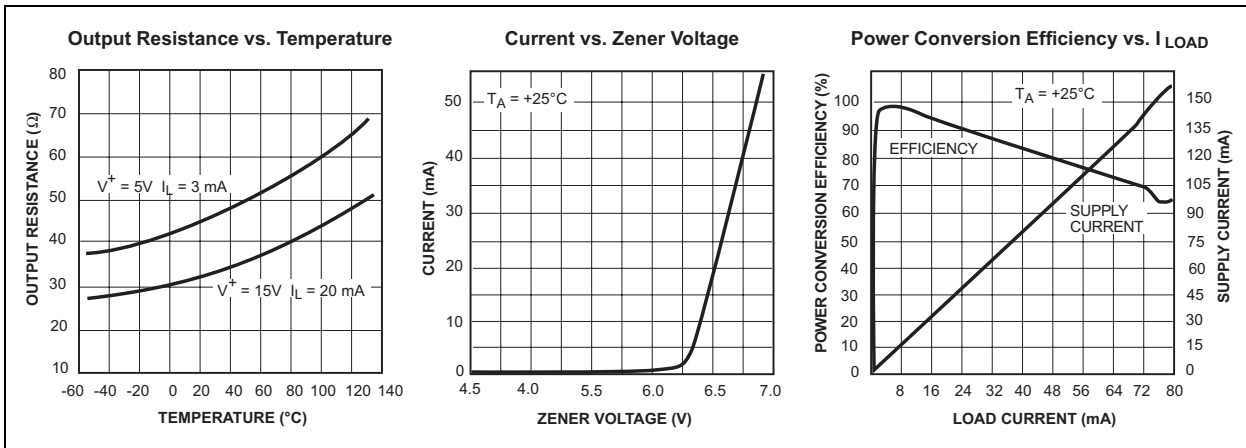
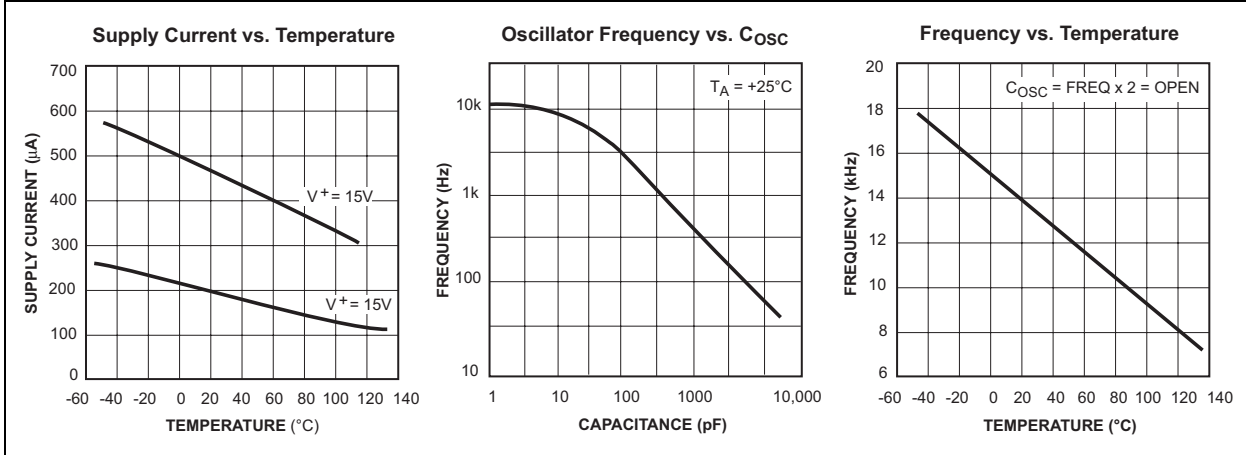

## 5.0 PACKAGING INFORMATION

### 5.1 Package Marking Information

Package marking data not available at this time.

### 5.2 Taping Form

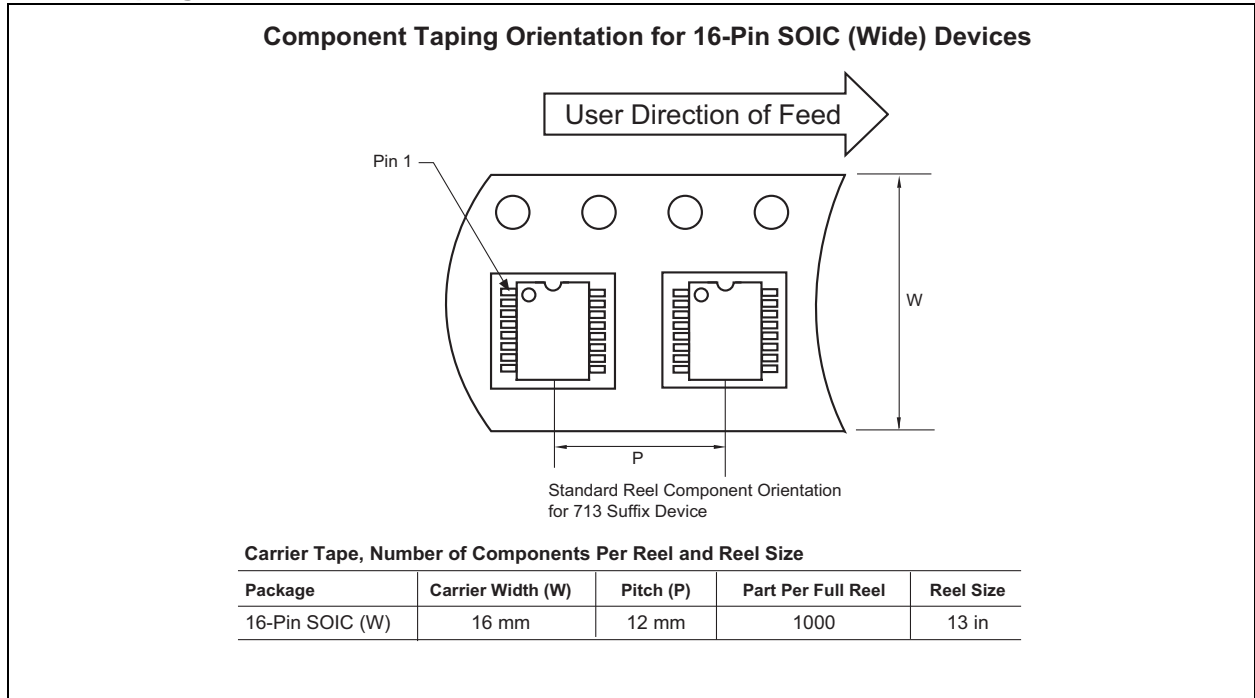

### 5.3 Package Dimensions

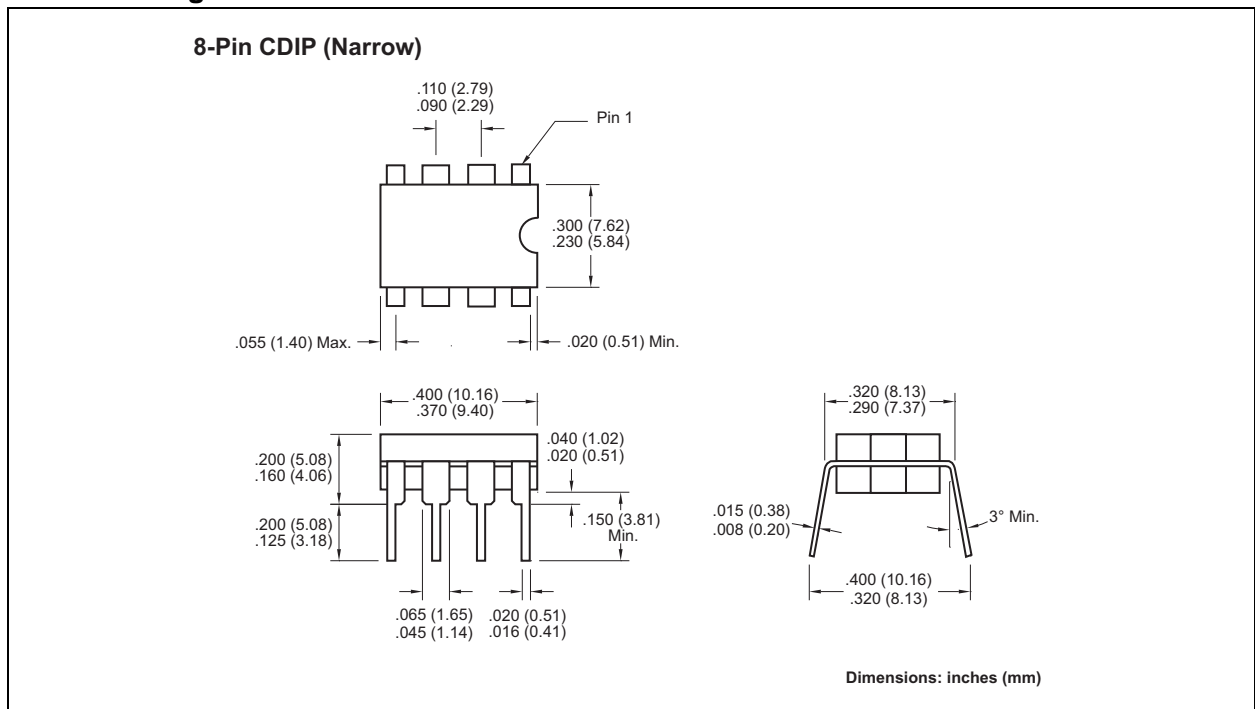

## Package Dimensions (Continued)

### 8-Pin Plastic DIP

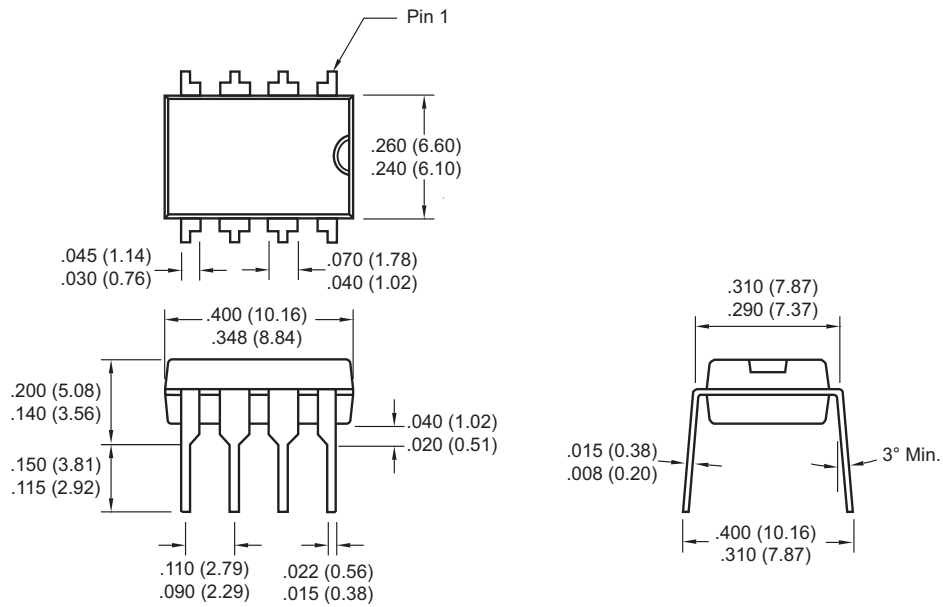

Dimensions: inches (mm)

### 16-Pin SOIC (Wide)

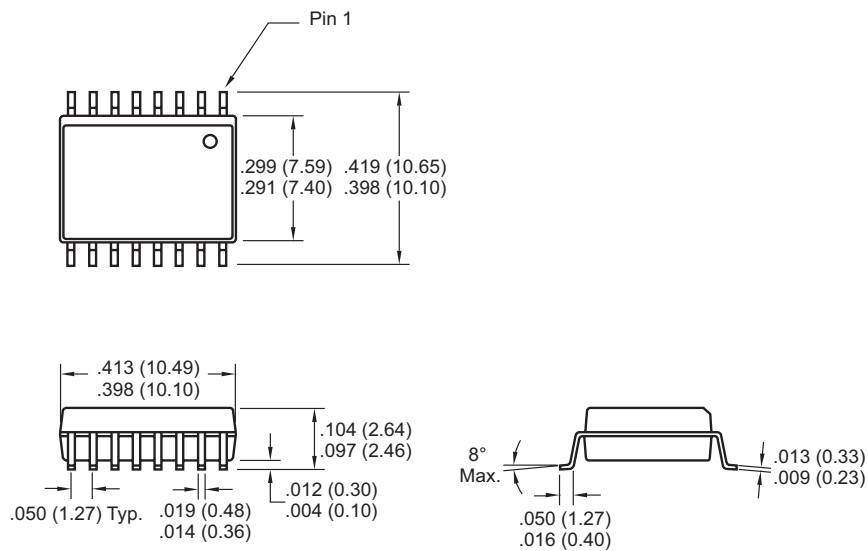

Dimensions: inches (mm)



## THE MICROCHIP WEB SITE

Microchip provides online support via our WWW site at [www.microchip.com](http://www.microchip.com). This web site is used as a means to make files and information easily available to customers. Accessible by using your favorite Internet browser, the web site contains the following information:

- **Product Support** – Data sheets and errata, application notes and sample programs, design resources, user's guides and hardware support documents, latest software releases and archived software
- **General Technical Support** – Frequently Asked Questions (FAQ), technical support requests, online discussion groups, Microchip consultant program member listing
- **Business of Microchip** – Product selector and ordering guides, latest Microchip press releases, listing of seminars and events, listings of Microchip sales offices, distributors and factory representatives

## CUSTOMER CHANGE NOTIFICATION SERVICE

Microchip's customer notification service helps keep customers current on Microchip products. Subscribers will receive e-mail notification whenever there are changes, updates, revisions or errata related to a specified product family or development tool of interest.

To register, access the Microchip web site at [www.microchip.com](http://www.microchip.com), click on Customer Change Notification and follow the registration instructions.

## CUSTOMER SUPPORT

Users of Microchip products can receive assistance through several channels:

- Distributor or Representative
- Local Sales Office
- Field Application Engineer (FAE)
- Technical Support
- Development Systems Information Line

Customers should contact their distributor, representative or field application engineer (FAE) for support. Local sales offices are also available to help customers. A listing of sales offices and locations is included in the back of this document.

**Technical support is available through the web site at: <http://support.microchip.com>**

# TC962

---

---

## READER RESPONSE

It is our intention to provide you with the best documentation possible to ensure successful use of your Microchip product. If you wish to provide your comments on organization, clarity, subject matter, and ways in which our documentation can better serve you, please FAX your comments to the Technical Publications Manager at (480) 792-4150.

Please list the following information, and use this outline to provide us with your comments about this document.

To: Technical Publications Manager  
RE: Reader Response  
From: Name \_\_\_\_\_  
Company \_\_\_\_\_  
Address \_\_\_\_\_  
City / State / ZIP / Country \_\_\_\_\_  
Telephone: (\_\_\_\_\_) \_\_\_\_\_ - \_\_\_\_\_ FAX: (\_\_\_\_\_) \_\_\_\_\_ - \_\_\_\_\_

Application (optional):

Would you like a reply? \_\_\_Y \_\_\_N

Device: TC962

Literature Number: DS21484C

Questions:

1. What are the best features of this document?

---

---

2. How does this document meet your hardware and software development needs?

---

---

3. Do you find the organization of this document easy to follow? If not, why?

---

---

4. What additions to the document do you think would enhance the structure and subject?

---

---

5. What deletions from the document could be made without affecting the overall usefulness?

---

---

6. Is there any incorrect or misleading information (what and where)?

---

---

7. How would you improve this document?

---

---

---

---

**Note the following details of the code protection feature on Microchip devices:**

- Microchip products meet the specification contained in their particular Microchip Data Sheet.
- Microchip believes that its family of products is one of the most secure families of its kind on the market today, when used in the intended manner and under normal conditions.
- There are dishonest and possibly illegal methods used to breach the code protection feature. All of these methods, to our knowledge, require using the Microchip products in a manner outside the operating specifications contained in Microchip's Data Sheets. Most likely, the person doing so is engaged in theft of intellectual property.
- Microchip is willing to work with the customer who is concerned about the integrity of their code.
- Neither Microchip nor any other semiconductor manufacturer can guarantee the security of their code. Code protection does not mean that we are guaranteeing the product as "unbreakable."

Code protection is constantly evolving. We at Microchip are committed to continuously improving the code protection features of our products. Attempts to break Microchip's code protection feature may be a violation of the Digital Millennium Copyright Act. If such acts allow unauthorized access to your software or other copyrighted work, you may have a right to sue for relief under that Act.

---

Information contained in this publication regarding device applications and the like is provided only for your convenience and may be superseded by updates. It is your responsibility to ensure that your application meets with your specifications. MICROCHIP MAKES NO REPRESENTATIONS OR WARRANTIES OF ANY KIND WHETHER EXPRESS OR IMPLIED, WRITTEN OR ORAL, STATUTORY OR OTHERWISE, RELATED TO THE INFORMATION, INCLUDING BUT NOT LIMITED TO ITS CONDITION, QUALITY, PERFORMANCE, MERCHANTABILITY OR FITNESS FOR PURPOSE. Microchip disclaims all liability arising from this information and its use. Use of Microchip devices in life support and/or safety applications is entirely at the buyer's risk, and the buyer agrees to defend, indemnify and hold harmless Microchip from any and all damages, claims, suits, or expenses resulting from such use. No licenses are conveyed, implicitly or otherwise, under any Microchip intellectual property rights.

#### **Trademarks**

The Microchip name and logo, the Microchip logo, Accuron, dsPIC, KEELOQ, microID, MPLAB, PIC, PICmicro, PICSTART, PRO MATE, PowerSmart, rPIC, and SmartShunt are registered trademarks of Microchip Technology Incorporated in the U.S.A. and other countries.

AmpLab, FilterLab, Migratable Memory, MXDEV, MXLAB, SEEVAL, SmartSensor and The Embedded Control Solutions Company are registered trademarks of Microchip Technology Incorporated in the U.S.A.

Analog-for-the-Digital Age, Application Maestro, dsPICDEM, dsPICDEM.net, dsPICworks, ECAN, ECONOMONITOR, FanSense, FlexROM, fuzzyLAB, In-Circuit Serial Programming, ICSP, ICEPIC, Linear Active Thermistor, Mindi, MiWi, MPASM, MPLIB, MPLINK, PICkit, PICDEM, PICDEM.net, PICLAB, PICtail, PowerCal, PowerInfo, PowerMate, PowerTool, REAL ICE, rLAB, rPICDEM, Select Mode, Smart Serial, SmartTel, Total Endurance, UNI/O, WiperLock and ZENA are trademarks of Microchip Technology Incorporated in the U.S.A. and other countries.

SQTP is a service mark of Microchip Technology Incorporated in the U.S.A.

All other trademarks mentioned herein are property of their respective companies.

© 2006, Microchip Technology Incorporated, Printed in the U.S.A., All Rights Reserved.

 Printed on recycled paper.

**QUALITY MANAGEMENT SYSTEM**  
**CERTIFIED BY DNV**  
**== ISO/TS 16949:2002 ==**

*Microchip received ISO/TS-16949:2002 certification for its worldwide headquarters, design and wafer fabrication facilities in Chandler and Tempe, Arizona, Gresham, Oregon and Mountain View, California. The Company's quality system processes and procedures are for its PICmicro® 8-bit MCUs, KEELOQ® code hopping devices, Serial EEPROMs, microperipherals, nonvolatile memory and analog products. In addition, Microchip's quality system for the design and manufacture of development systems is ISO 9001:2000 certified.*



---

---

## WORLDWIDE SALES AND SERVICE

---

---

### AMERICAS

**Corporate Office**  
2355 West Chandler Blvd.  
Chandler, AZ 85224-6199  
Tel: 480-792-7200  
Fax: 480-792-7277  
Technical Support:  
<http://support.microchip.com>  
Web Address:  
[www.microchip.com](http://www.microchip.com)

**Asia Pacific Office**  
Suites 3707-14, 37th Floor  
Tower 6, The Gateway  
Harbour City, Kowloon  
Hong Kong  
Tel: 852-2401-1200  
Fax: 852-2401-3431

**Atlanta**  
Alpharetta, GA  
Tel: 770-640-0034  
Fax: 770-640-0307

**Boston**  
Westborough, MA  
Tel: 774-760-0087  
Fax: 774-760-0088

**Chicago**  
Itasca, IL  
Tel: 630-285-0071  
Fax: 630-285-0075

**Dallas**  
Addison, TX  
Tel: 972-818-7423  
Fax: 972-818-2924

**Detroit**  
Farmington Hills, MI  
Tel: 248-538-2250  
Fax: 248-538-2260

**Kokomo**  
Kokomo, IN  
Tel: 765-864-8360  
Fax: 765-864-8387

**Los Angeles**  
Mission Viejo, CA  
Tel: 949-462-9523  
Fax: 949-462-9608

**San Jose**  
Mountain View, CA  
Tel: 650-215-1444  
Fax: 650-961-0286

**Toronto**  
Mississauga, Ontario,  
Canada  
Tel: 905-673-0699  
Fax: 905-673-6509

### ASIA/PACIFIC

**Australia - Sydney**  
Tel: 61-2-9868-6733  
Fax: 61-2-9868-6755

**China - Beijing**  
Tel: 86-10-8528-2100  
Fax: 86-10-8528-2104

**China - Chengdu**  
Tel: 86-28-8676-6200  
Fax: 86-28-8676-6599

**China - Fuzhou**  
Tel: 86-591-8750-3506  
Fax: 86-591-8750-3521

**China - Hong Kong SAR**  
Tel: 852-2401-1200  
Fax: 852-2401-3431

**China - Qingdao**  
Tel: 86-532-8502-7355  
Fax: 86-532-8502-7205

**China - Shanghai**  
Tel: 86-21-5407-5533  
Fax: 86-21-5407-5066

**China - Shenyang**  
Tel: 86-24-2334-2829  
Fax: 86-24-2334-2393

**China - Shenzhen**  
Tel: 86-755-8203-2660  
Fax: 86-755-8203-1760

**China - Shunde**  
Tel: 86-757-2839-5507  
Fax: 86-757-2839-5571

**China - Wuhan**  
Tel: 86-27-5980-5300  
Fax: 86-27-5980-5118

**China - Xian**  
Tel: 86-29-8833-7250  
Fax: 86-29-8833-7256

### ASIA/PACIFIC

**India - Bangalore**  
Tel: 91-80-4182-8400  
Fax: 91-80-4182-8422

**India - New Delhi**  
Tel: 91-11-5160-8631  
Fax: 91-11-5160-8632

**India - Pune**  
Tel: 91-20-2566-1512  
Fax: 91-20-2566-1513

**Japan - Yokohama**  
Tel: 81-45-471-6166  
Fax: 81-45-471-6122

**Korea - Gumi**  
Tel: 82-54-473-4301  
Fax: 82-54-473-4302

**Korea - Seoul**  
Tel: 82-2-554-7200  
Fax: 82-2-558-5932 or  
82-2-558-5934

**Malaysia - Penang**  
Tel: 60-4-646-8870  
Fax: 60-4-646-5086

**Philippines - Manila**  
Tel: 63-2-634-9065  
Fax: 63-2-634-9069

**Singapore**  
Tel: 65-6334-8870  
Fax: 65-6334-8850

**Taiwan - Hsin Chu**  
Tel: 886-3-572-9526  
Fax: 886-3-572-6459

**Taiwan - Kaohsiung**  
Tel: 886-7-536-4818  
Fax: 886-7-536-4803

**Taiwan - Taipei**  
Tel: 886-2-2500-6610  
Fax: 886-2-2508-0102

**Thailand - Bangkok**  
Tel: 66-2-694-1351  
Fax: 66-2-694-1350

### EUROPE

**Austria - Wels**  
Tel: 43-7242-2244-3910  
Fax: 43-7242-2244-393

**Denmark - Copenhagen**  
Tel: 45-4450-2828  
Fax: 45-4485-2829

**France - Paris**  
Tel: 33-1-69-53-63-20  
Fax: 33-1-69-30-90-79

**Germany - Munich**  
Tel: 49-89-627-144-0  
Fax: 49-89-627-144-44

**Italy - Milan**  
Tel: 39-0331-742611  
Fax: 39-0331-466781

**Netherlands - Drunen**  
Tel: 31-416-690399  
Fax: 31-416-690340

**Spain - Madrid**  
Tel: 34-91-708-08-90  
Fax: 34-91-708-08-91

**UK - Wokingham**  
Tel: 44-118-921-5869  
Fax: 44-118-921-5820

06/08/06