

## Features

- 16 Mbit SRAM Multi Chip Module
- Allows 32-, 16- or 8-bit access configuration
- Operating Voltage: 3.3V  $\pm$  0.3V
- Access Time
  - 20 ns, 18 ns for AT68166F
- Power Consumption
  - Active: 620 mW per byte (Max) @ 18ns - 415 mW per byte (Max) @ 50ns <sup>(1)</sup>
  - Standby: 13 mW (Typ)
- Military Temperature Range: -55 to +125°C
- TTL-Compatible Inputs and Outputs
- Asynchronous
- Die manufactured on Atmel 0.25  $\mu$ m Radiation Hardened Process
- No Single Event Latch Up below LET Threshold of 80 MeV/mg/cm<sup>2</sup>
- Tested up to a Total Dose of 300 krad (Si) according to MIL-STD-883 Method 1019
- ESD Better than 4000V
- Quality Grades:
  - QML-Q or V with SMD 5962-06229
  - ESCC
- 950 Mils Wide MQFP 68 Package
- Mass : 8.5 grams

Note: 1. Only for AT68166F-18. 450mW for AT68166F-20.

## Description

The AT68166F is a 16Mbit SRAM packaged in a hermetic Multi Chip Module (MCM) for space applications.

The AT68166F MCM incorporates four 4Mbit AT60142FT SRAM dice. It can be organized as either one bank of 512Kx8, two banks of 512Kx16 or four banks of 512Kx8. It combines rad-hard capabilities, a latch-up threshold of 80MeV.cm<sup>2</sup>/mg, a Multiple Bit Upset immunity and a total dose tolerance of 300Krad, with a fast access time.

The MCM packaging technology allows a reduction of the PCB area by 50% with a weight savings of 75% compared to four 4Mbit packages.

Thanks to the small size of the 4Mbit SRAM die, Atmel has been able to accommodate the assembly of the four dice on one side of the package which facilitates the power dissipation.

The compatibility with other products allows designers to easily migrate to the Atmel AT68166F memory.

The AT68166F is powered at 3.3V.

The AT68166F is processed according to the test methods of the latest revision of the MIL-PRF-38535 or the ESCC 9000.



## Rad Hard 16 MegaBit 3.3V SRAM Multi- Chip Module

### AT68166F



**Block Diagram** Figure 1. AT68166F Block Diagram

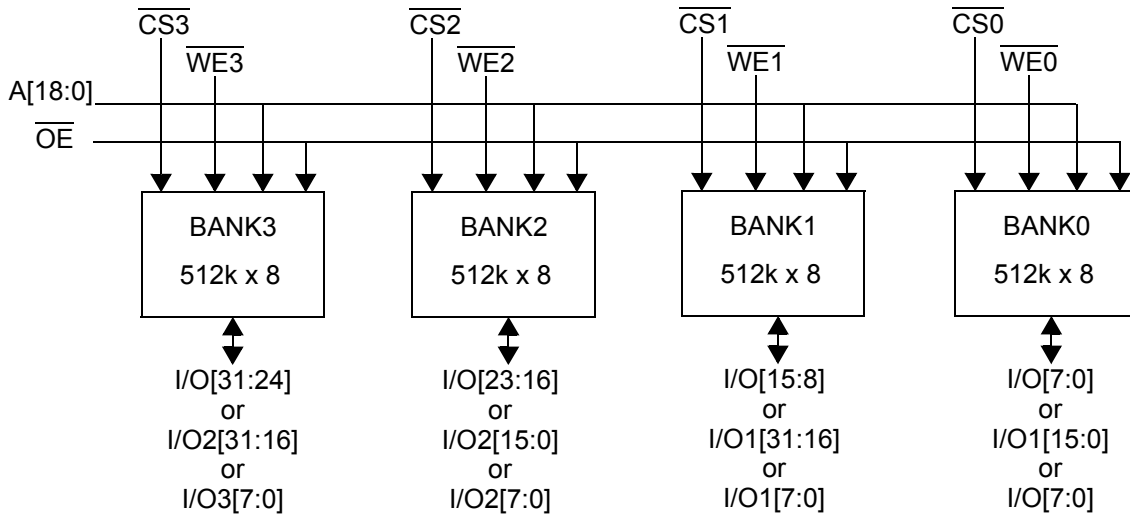

**Figure 2.** 512K x 8 Banks Block Diagram (AT60142F)

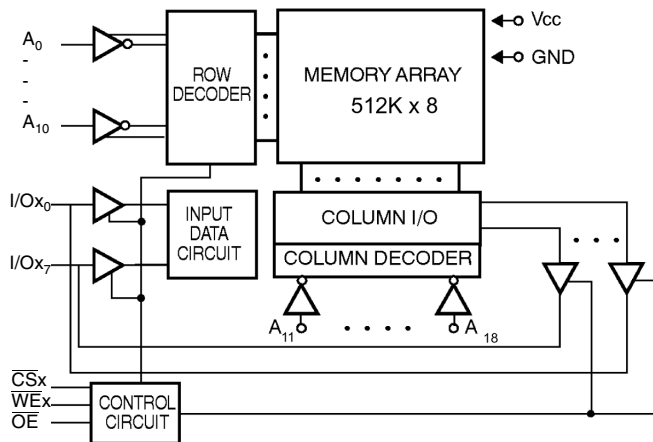

## Packages

AT68166F and AT68166G are packed in MQFP68.

	Access Time		
	20 ns	18 ns	<18 ns
AT68166F	YM	YS	
AT68166G			YS

The pin assignment depends on the access time. There are 2 versions:

- YM package where 3 pins are not connected.
- YS package where the 3 above pins are connected to GND or  $V_{cc}$ .

## Pin Configuration

**Table 1.** AT68166F pin assignment in YS package

Lead	Signal	Lead	Signal	Lead	Signal	Lead	Signal
1	I/O0[0]	18	VCC	35	I/O3[7]	52	VCC
2	I/O0[1]	19	A11	36	I/O3[6]	53	A10
3	I/O0[2]	20	A12	37	I/O3[5]	54	A9
4	I/O0[3]	21	A13	38	I/O3[4]	55	A8
5	I/O0[4]	22	A14	39	I/O3[3]	56	A7
6	I/O0[5]	23	A15	40	I/O3[2]	57	A6
7	I/O0[6]	24	A16	41	I/O3[1]	58	WE0
8	I/O0[7]	25	CS0	42	I/O3[0]	59	CS3
9	GND	26	OE	43	GND	60	GND
10	I/O1[0]	27	CS1	44	I/O2[7]	61	CS2
11	I/O1[1]	28	A17	45	I/O2[6]	62	A5
12	I/O1[2]	29	WE1	46	I/O2[5]	63	A4
13	I/O1[3]	30	WE2	47	I/O2[4]	64	A3
14	I/O1[4]	31	WE3	48	I/O2[3]	65	A2
15	I/O1[5]	32	A18	49	I/O2[2]	66	A1
16	I/O1[6]	33	GND	50	I/O2[1]	67	A0
17	I/O1[7]	34	VCC	51	I/O2[0]	68	VCC

Notes: 1. In YM package leads 33, 34 and 68 are not connected.

**Figure 3.** AT68166F pin assignment in YM package

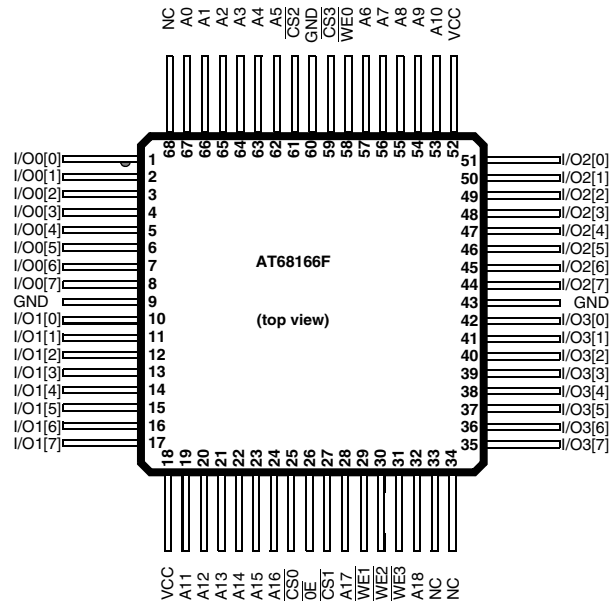

**Figure 4.** AT68166F pin assignment in YS package

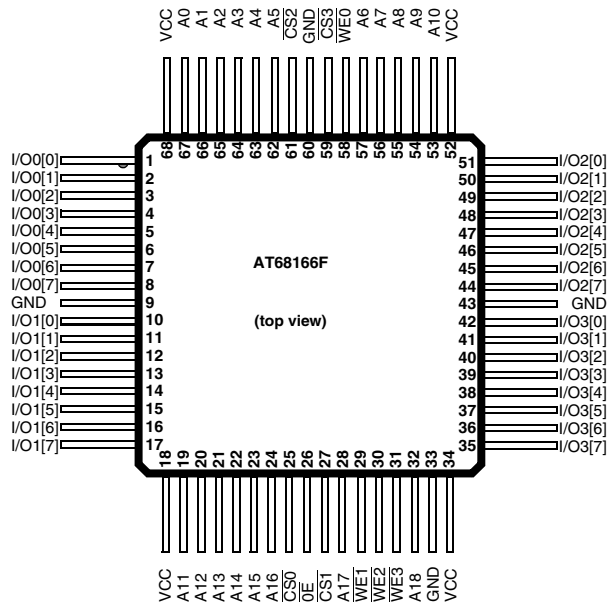

## Pin Description

**Table 2.** Pin Names

Name	Description
A0 - A18	Address Inputs
I/O0 - I/O31	Data Input/Output
$\overline{CS0}$ - $\overline{CS3}$	Chip Select
$\overline{WE0}$ - $\overline{WE3}$	Write Enable
$\overline{OE}$	Output Enable
VCC	Power Supply
GND <sup>(1)</sup>	Ground

Note: 1. The package lid is connected to GND

**Table 3.** Truth Table<sup>(1)</sup>

$\overline{CSx}$	$\overline{WEx}$	$\overline{OE}$	Inputs/Outputs	Mode
H	X	X	Z	Standby
L	H	L	Data Out	Read
L	L	X	Data In	Write
L	H	H	Z	Output Disable

Note: 1. L=low, H=high, X= H or L, L=high impedance.



## Electrical Characteristics

### Absolute Maximum Ratings\*

Supply Voltage to GND Potential: .....	-0.5V + 4.6V
Voltage range on any input: .....	GND -0.5V to 4.6V
Voltage range on any output: .....	GND -0.5V to 4.6V
Storage Temperature: .....	-65°C to + 150°C
Output Current from Output Pins: .....	20 mA
Electrostatic Discharge Voltage: .....	> 4000V (MIL STD 883D Method 3015.3)

\*NOTE:

Stresses beyond those listed under "Absolute Maximum Ratings" may cause permanent damage to the device. This is a stress rating only and functional operation of the device at these or any other conditions beyond those indicated in the operational sections of this specification is not implied. **Exposure between recommended DC operating and absolute maximum rating conditions for extended periods may affect device reliability.**

### Military Operating Range

Operating Voltage	Operating Temperature
3.3 ± 0.3V	-55°C to + 125°C

### Recommended DC Operating Conditions

Parameter	Description	Min	Typ	Max	Unit
V <sub>CC</sub>	Supply voltage	3	3.3	3.6	V
GND	Ground	0.0	0.0	0.0	V
V <sub>IL</sub>	Input low voltage	GND - 0.3	0.0	0.8	V
V <sub>IH</sub>	Input high voltage	2.2	–	V <sub>CC</sub> + 0.3	V

### Capacitance

Parameter	Description	Min	Typ	Max	Unit
C <sub>in</sub> <sup>(1)</sup> (OE and Ax)	Input capacitance	–	–	48	pF
C <sub>in</sub> <sup>(1)</sup> (CSx and WEx)	Input capacitance	–	–	12	pF
C <sub>io</sub> <sup>(1)</sup>	I/O capacitance	–	–	12	pF

Note: 1. Guaranteed but not tested.

## DC Parameters

Parameter	Description	Minimum	Typical	Maximum	Unit
IIX <sup>(1)</sup>	Input leakage current	-1	-	1	μA
IOZ <sup>(1)</sup>	Output leakage current	-1	-	1	μA
VOL <sup>(2)</sup>	Output low voltage	-	-	0.4	V
VOH <sup>(3)</sup>	Output high voltage	2.4	-	-	V

Notes: 1.  $GND < V_{IN} < V_{CC}$ ,  $GND < V_{OUT} < V_{CC}$  Output Disabled.  
 2.  $V_{CC}$  min.  $I_{OL} = 8$  mA  
 3.  $V_{CC}$  min.  $I_{OH} = -4$  mA

## Consumption

Symbol	Description	TAVAV/TAVAW Test Condition	AT68166F-20	AT68166F-18	Unit	Value
$I_{CCSB}^{(1)}$	Standby Supply Current	-	10	7	mA	max
$I_{CCSB1}^{(2)}$	Standby Supply Current	-	8	6	mA	max
$I_{CCOP}^{(3)}$ Read per byte	Dynamic Operating Current	18 ns	-	170	mA	max
		20 ns	170	165		
		50 ns	85	80		
		1 μs	15	12		
$I_{CCOP}^{(4)}$ Write per byte	Dynamic Operating Current	18 ns	-	145	mA	max
		20 ns	150	140		
		50 ns	125	115		
		1 μs	110	105		

Notes: 1. All  $\overline{CSx} \geq V_{IH}$   
 2. All  $\overline{CSx} \geq V_{CC} - 0.3V$   
 3.  $F = 1/t_{TAVAV}$ ,  $I_{out} = 0$  mA,  $\overline{WEX} = \overline{OE} = V_{IH}$ ,  $V_{IN} = GND/V_{CC}$ ,  $V_{CC}$  max.  
 4.  $F = 1/t_{TAVAW}$ ,  $I_{out} = 0$  mA,  $\overline{WEX} = V_{IL}$ ,  $\overline{OE} = V_{IH}$ ,  $V_{IN} = GND/V_{CC}$ ,  $V_{CC}$  max.

## Data Retention Mode

Atmel CMOS RAM's are designed with battery backup in mind. Data retention voltage and supply current are guaranteed over temperature. The following rules insure data retention:

1. During data retention chip select  $\overline{CSx}$  must be held high within  $V_{CC}$  to  $V_{CC} - 0.2V$ .
2. Output Enable ( $\overline{OE}$ ) should be held high to keep the RAM outputs high impedance, minimizing power dissipation.
3. During power-up and power-down transitions  $\overline{CSx}$  and  $\overline{OE}$  must be kept between  $V_{CC} + 0.3V$  and 70% of  $V_{CC}$ .
4. The RAM can begin operation  $> t_R$  ns after  $V_{CC}$  reaches the minimum operation voltages (3V).

**Figure 5.** Data Retention Timing

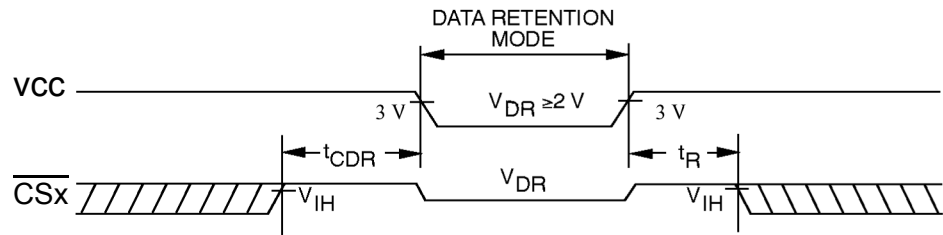

## Data Retention Characteristics

Parameter	Description	Min	Typ $T_A = 25^\circ C$	Max	Unit
$V_{CCDR}$	$V_{CC}$ for data retention	2.0	–	–	V
$t_{CDR}$	Chip deselect to data retention time	0.0	–	–	ns
$t_R$	Operation recovery time	$t_{AVAV}^{(1)}$	–	–	ns
$I_{CCDR}^{(2)}$	Data retention current	–	3	6 (AT68166F-20)	mA
				4.5 (AT68166F-18)	

1.  $T_{AVAV}$  = Read cycle time.
2. All  $CSx = V_{CC}$ ,  $V_{IN} = GND/V_{CC}$ .



AC Characteristics

Temperature Range:.....-55 +125°C  
 Supply Voltage: ..... 3.3 ±0.3V  
 Input Pulse Levels: ..... GND to 3.0V  
 Input Rise and Fall Times:..... 3ns (10 - 90%)  
 Input and Output Timing Reference Levels: ..... 1.5V  
 Output Loading I<sub>OL</sub>/I<sub>OH</sub>:..... See Figure 3

Figure 6. AC Test Loads Waveforms

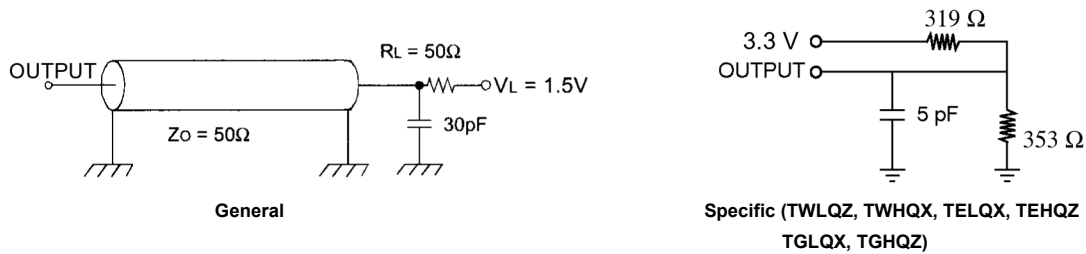

Write Cycle

Table 4. Write cycle timings<sup>(1)</sup>

Symbol	Parameter	AT68166F-20		AT68166F-18		Unit
		min	max	min	max	
TAVAW	Write cycle time	20	-	18	-	ns
TAVWL	Address set-up time	2	-	2	-	ns
TAVWH	Address valid to end of write	14	-	11	-	ns
TDVWH	Data set-up time	9	-	8	-	ns
TELWH	$\overline{CS}$ low to write end	12	-	12	-	ns
TWLQZ	Write low to high Z <sup>(2)</sup>	-	10	-	8	ns
TWLWH	Write pulse width	12	-	9	-	ns
TWHAX	Address hold from end of write	0	-	0	-	ns
TWHDX	Data hold time	2	-	1	-	ns
TWHQX	Write high to low Z <sup>(2)</sup>	5	-	3	-	ns

- Notes: 1. Timings figures applicable for 8-bit, 16-bit and 32-bit mode.  
 2. Parameters guaranteed, not tested, with output loading 5 pF. (See “AC Test Loads Waveforms” on page 9.)

**Figure 7. Write Cycle 1.  $\overline{WE}$  Controlled,  $\overline{OE}$  High During Write**

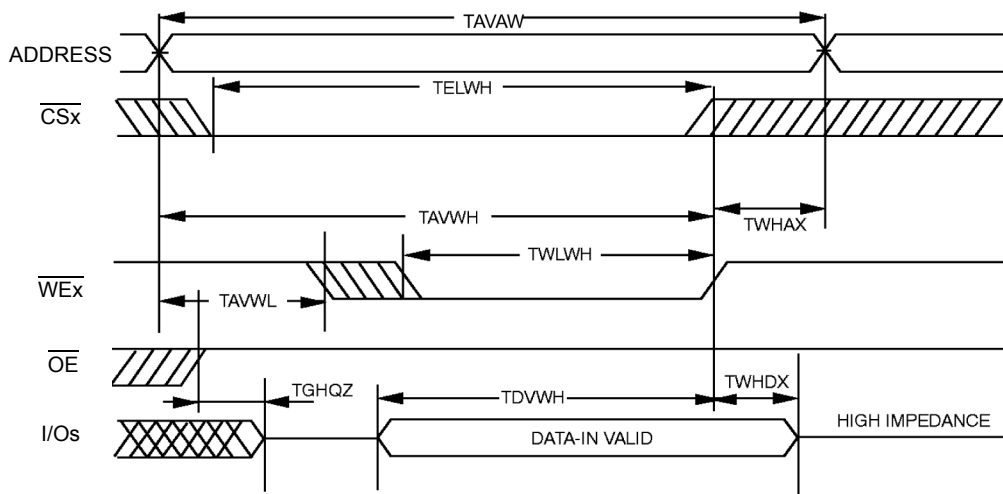

**Figure 8. Write Cycle 2.  $\overline{WE}$  Controlled,  $\overline{OE}$  Low**

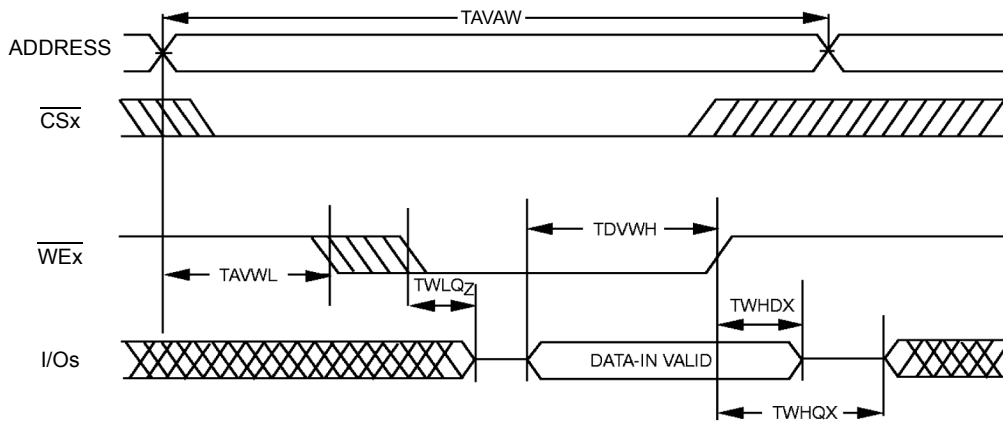

**Figure 9. Write Cycle 3.  $\overline{CS}$  Controlled**

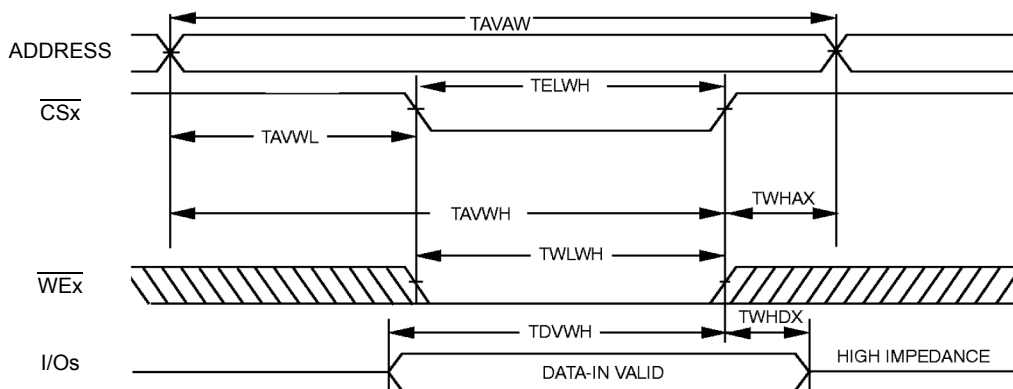

The internal write time of the memory is defined by the overlap of  $\overline{CS}$  Low and  $\overline{WE}$  LOW. Both signals must be activated to initiate a write and either signal can terminate a write by going in active mode. The data input setup and hold timing should be referenced to the active edge of the signal that terminates the write. Data out is high impedance if  $\overline{OE} = V_{IH}$ .

## Read Cycle

**Table 5.** Read cycle timings<sup>(1)</sup>

Symbol	Parameter	AT68166F-20		AT68166F-18		Unit
		min	max	min	max	
TAVAV	Read cycle time	20	-	18	-	ns
TAVQV	Address access time	-	20	-	18	ns
TAVQX	Address valid to low Z	5	-	5	-	ns
TELQV	Chip-select access time	-	20	-	18	ns
TELQX	$\overline{CS}$ low to low Z <sup>(2)</sup>	5	-	5	-	ns
TEHQZ	$\overline{CS}$ high to high Z <sup>(2)</sup>	-	9	-	8	ns
TGLQV	Output Enable access time	-	11	-	8	ns
TGLQX	$\overline{OE}$ low to low Z <sup>(2)</sup>	2	-	2	-	ns
TGHQZ	$\overline{OE}$ high to high Z <sup>(2)</sup>	-	9	-	8	ns

- Notes: 1. Timings figures applicable for 8-bit, 16-bit and 32-bit mode.  
 2. Parameters guaranteed, not tested, with output loading 5 pF. (See “AC Test Loads Waveforms” on page 9.)

**Figure 10.** Read Cycle nb 1: Address Controlled ( $\overline{CS} = \overline{OE} = V_{IL}$ ,  $\overline{WE} = V_{IH}$ )

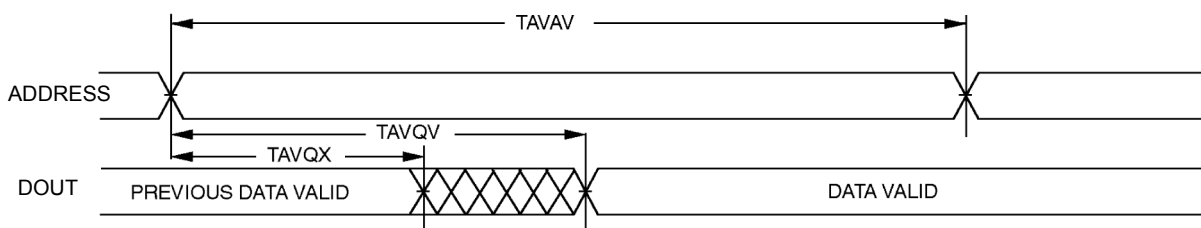

**Figure 11.** Read Cycle nb 2: Chip Select Controlled ( $\overline{WE} = V_{IH}$ )

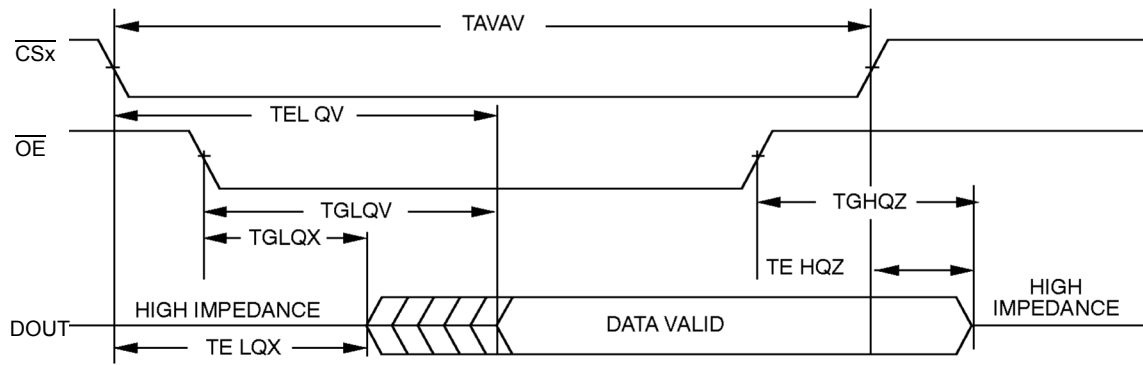

## Typical Applications

This section presents some standard implementations of the AT68166F in application.

### 32-bit mode application

When used on a 32-bit (word) application, the module shall be connected as follow :

- The 32 lines of data are connected to distinct data lines
- The four  $\overline{CS}_x$  are connected together and linked to a single host  $\overline{CS}$  output
- Each one of the four  $\overline{WE}_x$  is connected to a dedicated  $\overline{WE}$  line on the host to allow byte, half word and word format write.

**Figure 12.** 32-bit typical application ( 1 SRAM bank)

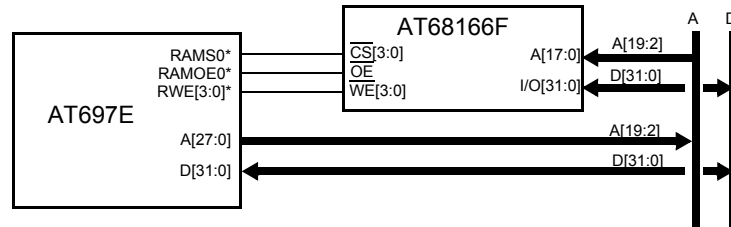

### 16-bit mode application

When used on a 16-bit (half word) application, the module can be connected as presented in the following figure. This allows use of a single AT68166F part for two SRAM memory banks.

All input controls of the AT68166F not used in the application shall be pulled-up.

**Figure 13.** 16-bit typical application (two SRAM banks)

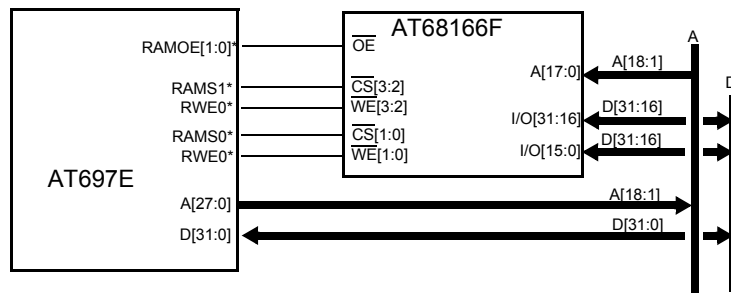

### 8-bit mode application

When used on a 8-bit (byte) application, the module can be connected as presented in the following figure. This allows use of a single AT68166F part for up to four SRAM memory banks.

All input controls of the AT68166F not used in the application shall be pulled-up.

**Figure 14.** 8-bit typical application (two SRAM banks)

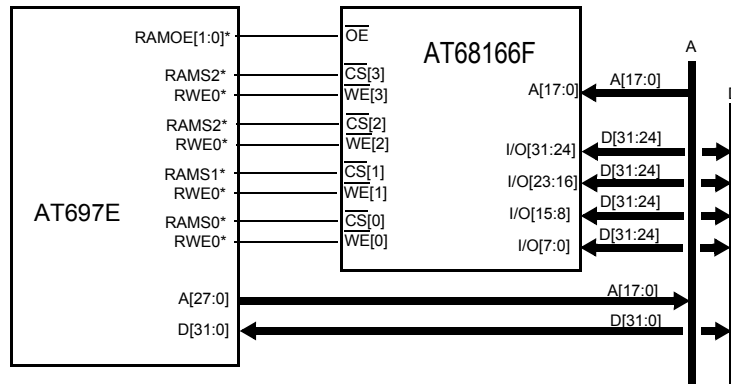

## Ordering Information

Part Number	Temperature Range	Speed	Package	Flow
<b>AT68166F</b>				
AT68166F-YM20-E	25°C	20 ns	MQFP68	Engineering Samples
5962-0622902QXC	-55° to +125°C	20 ns	MQFP68	QML Q
5962-0622902VXC	-55° to +125°C	20 ns	MQFP68	QML V
5962R0622902VXC	-55° to +125°C	20 ns	MQFP68	QML V RHA
AT68166F-YM20-SCC	-55° to +125°C	20 ns	MQFP68	ESCC
AT68166F-YS18-E	25°C	18 ns	MQFP68	Engineering Samples
5962-0622904QYC	-55° to +125°C	18 ns	MQFP68	QML Q
5962-0622904VYC	-55° to +125°C	18 ns	MQFP68	QML V
5962R0622904VYC	-55° to +125°C	18 ns	MQFP68	QML V RHA
AT68166F-YS18-SCC <sup>(1)</sup>	-55° to +125°C	18 ns	MQFP68	ESCC

Note: 1. Will be replaced by SMD part number when available.

# Package Drawings

## 68-lead Quad Flat Pack (950 Mils) with non conductive tie bar

68 LEADS FLAT PACK CERAMIC TIE BAR

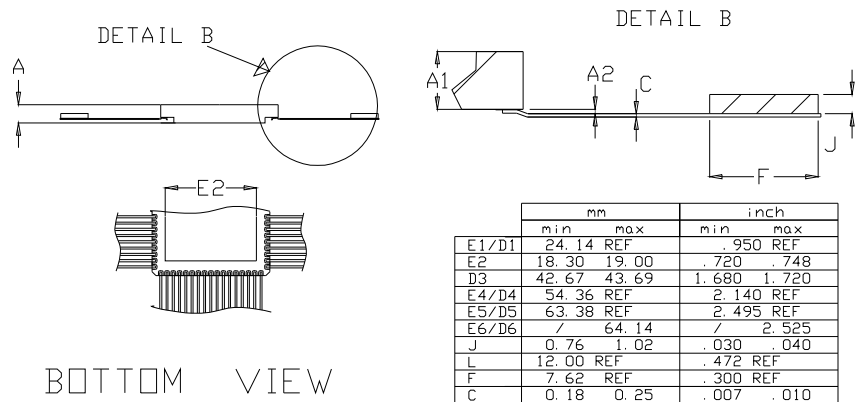
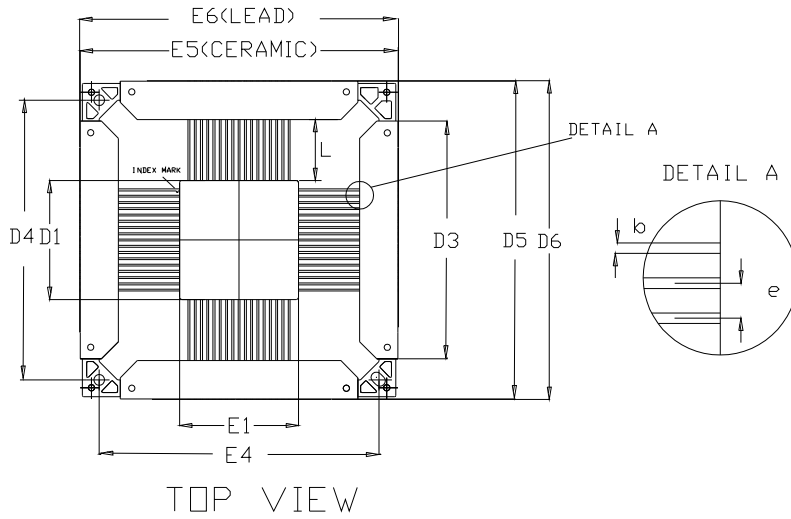

	mm		inch	
	min	max	min	max
E1/D1	24.14	REF	.950	REF
E2	18.30	19.00	.720	.748
D3	42.67	43.69	1.680	1.720
E4/D4	54.36	REF	2.140	REF
E5/D5	63.38	REF	2.495	REF
E6/D6	/	64.14	/	2.525
J	0.76	1.02	.030	.040
L	12.00	REF	.472	REF
F	7.62	REF	.300	REF
C	0.18	0.25	.007	.010
A	3.72	4.70	.146	.185
A1	2.72	3.41	.107	.134
A2	0.20	BSC	.008	BSC
e	1.27	BSC	.050	BSC
b	0.33	0.43	.013	.017

- Note:
1. Lid is connected to Ground.
  2. YM and YS package drawings are identical.



## Document Revision History

<b>Changes from Rev. A to Rev. B</b>	<ol style="list-style-type: none"><li>1. Suppression of version AT68166G</li><li>2. Update of Absolute Maximum Ratings section</li></ol>
--	--



## Atmel Corporation

2325 Orchard Parkway  
San Jose, CA 95131, USA  
Tel: 1(408) 441-0311  
Fax: 1(408) 487-2600

## Regional Headquarters

### Europe

Atmel Sarl  
Route des Arsenalux 41  
Case Postale 80  
CH-1705 Fribourg  
Switzerland  
Tel: (41) 26-426-5555  
Fax: (41) 26-426-5500

### Asia

Room 1219  
Chinachem Golden Plaza  
77 Mody Road Tsimshatsui  
East Kowloon  
Hong Kong  
Tel: (852) 2721-9778  
Fax: (852) 2722-1369

### Japan

9F, Tonetsu Shinkawa Bldg.  
1-24-8 Shinkawa  
Chuo-ku, Tokyo 104-0033  
Japan  
Tel: (81) 3-3523-3551  
Fax: (81) 3-3523-7581

## Atmel Operations

### Memory

2325 Orchard Parkway  
San Jose, CA 95131, USA  
Tel: 1(408) 441-0311  
Fax: 1(408) 436-4314

### Microcontrollers

2325 Orchard Parkway  
San Jose, CA 95131, USA  
Tel: 1(408) 441-0311  
Fax: 1(408) 436-4314

La Chantrerie  
BP 70602  
44306 Nantes Cedex 3, France  
Tel: (33) 2-40-18-18-18  
Fax: (33) 2-40-18-19-60

### ASIC/ASSP/Smart Cards

Zone Industrielle  
13106 Rousset Cedex, France  
Tel: (33) 4-42-53-60-00  
Fax: (33) 4-42-53-60-01

1150 East Cheyenne Mtn. Blvd.  
Colorado Springs, CO 80906, USA  
Tel: 1(719) 576-3300  
Fax: 1(719) 540-1759

Scottish Enterprise Technology Park  
Maxwell Building  
East Kilbride G75 0QR, Scotland  
Tel: (44) 1355-803-000  
Fax: (44) 1355-242-743

### RF/Automotive

Theresienstrasse 2  
Postfach 3535  
74025 Heilbronn, Germany  
Tel: (49) 71-31-67-0  
Fax: (49) 71-31-67-2340

1150 East Cheyenne Mtn. Blvd.  
Colorado Springs, CO 80906, USA  
Tel: 1(719) 576-3300  
Fax: 1(719) 540-1759

### Biometrics/Imaging/Hi-Rel MPU/ High Speed Converters/RF Datacom

Avenue de Rochepleine  
BP 123  
38521 Saint-Egreve Cedex, France  
Tel: (33) 4-76-58-30-00  
Fax: (33) 4-76-58-34-80

---

## Literature Requests

[www.atmel.com/literature](http://www.atmel.com/literature)

**Disclaimer:** The information in this document is provided in connection with Atmel products. No license, express or implied, by estoppel or otherwise, to any intellectual property right is granted by this document or in connection with the sale of Atmel products. **EXCEPT AS SET FORTH IN ATMEL'S TERMS AND CONDITIONS OF SALE LOCATED ON ATMEL'S WEB SITE, ATMEL ASSUMES NO LIABILITY WHATSOEVER AND DISCLAIMS ANY EXPRESS, IMPLIED OR STATUTORY WARRANTY RELATING TO ITS PRODUCTS INCLUDING, BUT NOT LIMITED TO, THE IMPLIED WARRANTY OF MERCHANTABILITY, FITNESS FOR A PARTICULAR PURPOSE, OR NON-INFRINGEMENT. IN NO EVENT SHALL ATMEL BE LIABLE FOR ANY DIRECT, INDIRECT, CONSEQUENTIAL, PUNITIVE, SPECIAL OR INCIDENTAL DAMAGES (INCLUDING, WITHOUT LIMITATION, DAMAGES FOR LOSS OF PROFITS, BUSINESS INTERRUPTION, OR LOSS OF INFORMATION) ARISING OUT OF THE USE OR INABILITY TO USE THIS DOCUMENT, EVEN IF ATMEL HAS BEEN ADVISED OF THE POSSIBILITY OF SUCH DAMAGES.** Atmel makes no representations or warranties with respect to the accuracy or completeness of the contents of this document and reserves the right to make changes to specifications and product descriptions at any time without notice. Atmel does not make any commitment to update the information contained herein. Unless specifically provided otherwise, Atmel products are not suitable for, and shall not be used in, automotive applications. Atmel's Atmel's products are not intended, authorized, or warranted for use as components in applications intended to support or sustain life.

©2007 Atmel Corporation. All rights reserved. Atmel®, logo and combinations thereof, and Everywhere You Are® are the trademarks or registered trademarks, of Atmel Corporation or its subsidiaries. Other terms and product names may be trademarks of others.



Printed on recycled paper.

7747B-AERO-04/09