



PRESS FIT AVALANCHE AUTOMOTIVE RECTIFIER (BOSCH)

PRBA30L

AVALANCHE VOLTAGE 20 to 24 Volts

CURRENT 30 Amperes

Technical Specifecation:

Features:

- High power capability
- Economical
- Avalanche Voltage: 20V to 24V

MECHANICAL DATA

- Case: transfer molded plastic
- Epoxy: UL94-0 rate flame ratardant
- Polarity: As marked of case bottom
- Structural: With cell
- Technology cell vacuum soldered
- Lead: Plated slug, solderable per MIL-STD-202E Method 208C
- Weight: 0.29ounce, 8.09 Grams

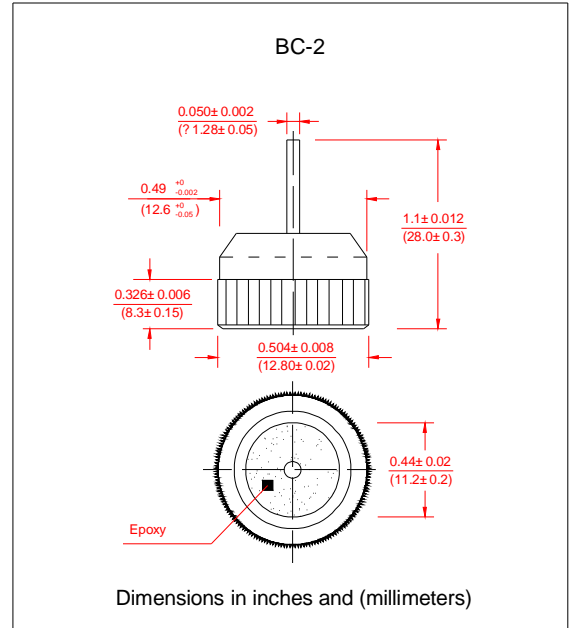

MAXIMUM RATINGS AND ELECTRICAL CHARACTERISTICS

- Ratings at 25°C ambient temperature unless otherwise specified
- Single Phase, half wave, 60Hz, resistive or inductive load
- For capacitive load derate current by 20%

| Electrical Characteristics @ 25°C | SYMBOLS | MIN | NOMINAL | MAX | UNITS |
|--|----------------|-----|-------------|------|-------|
| Peak Repetitive Reverse Voltage | V_{RRM} | | 17 | | Volts |
| Working Peak Reverse Voltage | V_{RRM} | | 17 | | |
| DC Blocking Voltage | V_{DC} | | 17 | | |
| Average Rectified Forward Current ($T_c=125^\circ\text{C}$) | I_o | | 30 | | Amps |
| Repetitive Peak Reverse Surge Current $T_c=10\text{msec}$ Dury Cycle<1% | I_{RSM} | | 30 | | Amps |
| Breakdown Voltage (V_{br} @ $i_r=100\text{mA}$, $T_c=25^\circ\text{C}$) $i_r=90\text{Amps}$, $T_c=150^\circ\text{C}$, $PW=80\text{uSec}$ | V_{br1} | 20 | 22 | 24 | Volts |
| | V_{br2} | | | 32 | Volts |
| Forward Voltage Drop @ $I_f=100\text{Amps}$ <300uSec | V_F | | 1.05 | 1.08 | Volts |
| Peak Forward Surge Current | I_{FSM} | | 500 | | Amps |
| Reverse Leakage ($V_R=17\text{Vdc}$) $T_A=25^\circ\text{C}$ | I_R | | 1.0 | 2.0 | uAmps |
| Operating and Storage Junction Temperature Range | T_J, T_{STG} | | -65 to +175 | | °C |

Notes: 1. Enough heatsink must be considered in application.

