



TAI-SAW TECHNOLOGY CO., LTD.

No. 3, Industrial 2nd Rd., Ping-Chen Industrial District,
Taoyuan, 324, Taiwan, R.O.C.

TEL: 886-3-4690038 FAX: 886-3-4697532

E-mail: tstsales@mail.taisaw.com Web: www.taisaw.com

Approval Sheet For Product Specification

Issued Date:

Product Name: SAW Resonator 303.6 MHz SMD 5X5 mm

TST Parts No.: TC0253A

Customer Parts No.: _____

Company: _____
Division: _____
Approved by : _____
Date: _____

Checked by: _____ Asin Lin

Approval by: _____ Francis Chen

Date: _____ 2004/6/25



TAI-SAW TECHNOLOGY CO., LTD.

No. 3, Industrial 2nd Rd., Ping-Chen Industrial District,
Taoyuan, 324, Taiwan, R.O.C.

TEL: 886-3-4690038 FAX: 886-3-4697532

E-mail: tstsales@mail.taisaw.com Web: www.taisaw.com

SAW Resonator 303.6 MHz

MODEL NO.: TC0253A

REV. NO.:1

A. FEATURES:

1. 1-Port Resonator.

B. MAXIMUM RATING:

1. Input Power Level: 0 dBm

2. DC voltage: 12 V

3. Operating Temperature: -40°C to +85°C

4. Storage Temperature: -40°C to +85°C

C. ELECTRICAL CHARACTERISTICS:

Characteristic	Units	Minimum	Typical	Maximum
Center frequency Fr	MHz	303.525	303.600	303.675
Insertion Loss IL	dB		1.5	2.5
Unloaded Quality factor		6000		
Equivalent Elements				
Motional capacitance C1	fF	-	2.720	-
Motional inductance L1	μH	-	101.03	-
Motional resistance R1	Ohm	-	17.014	-
Parallel capacitance Co	pF	-	4.586	-
Temp.coeff.	ppm/c*2	-	0.032	-
Turnover To	deg.C	20	40	50
Package size		SMD 5X5X1.4mm		

RoHS Compliant
Lead free
Lead-free soldering

D. OUTLINE DRAWING:

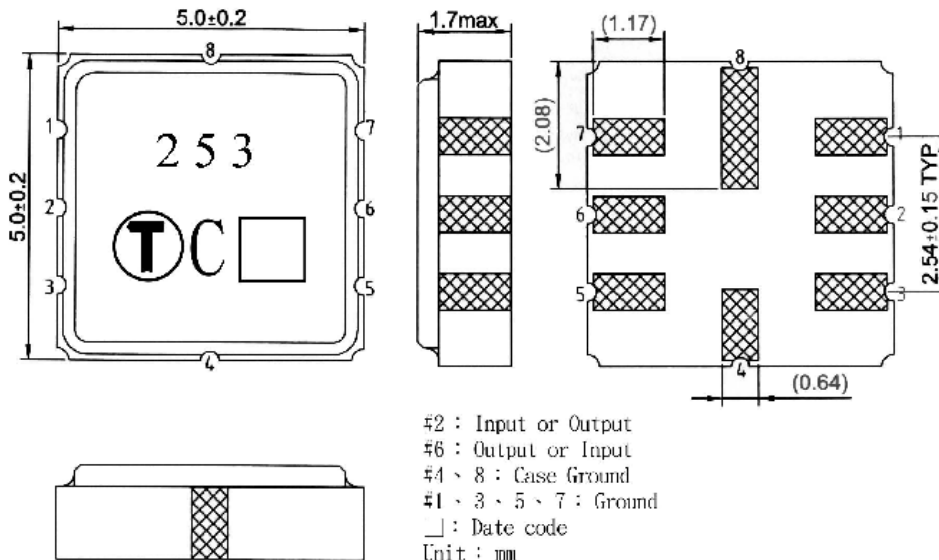

E. EQUIVALENT CIRCUIT:

One-Port Resonator:

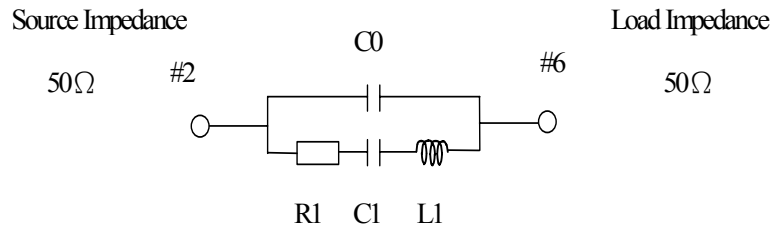

F. FREQUENCY CHARACTERISTICS:

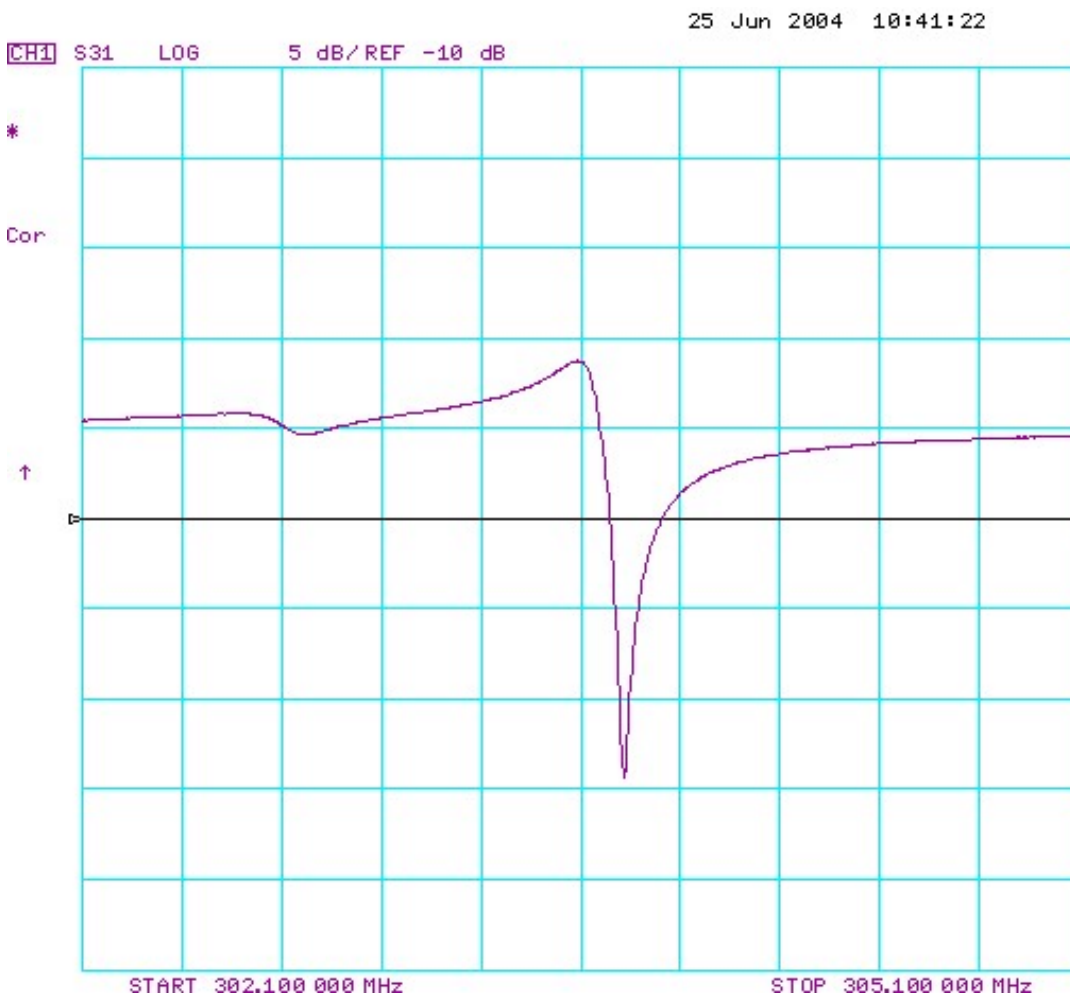

G. TEST CIRCUIT:

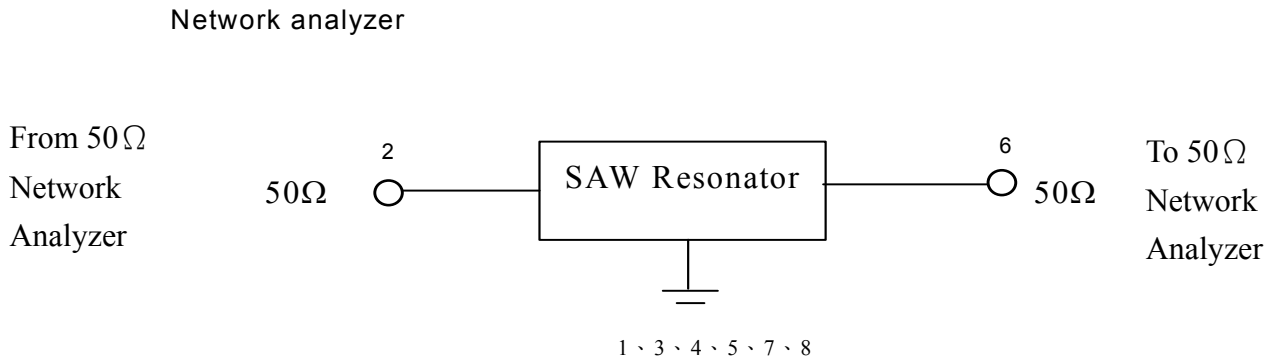

H. PCB FOOTPRINT

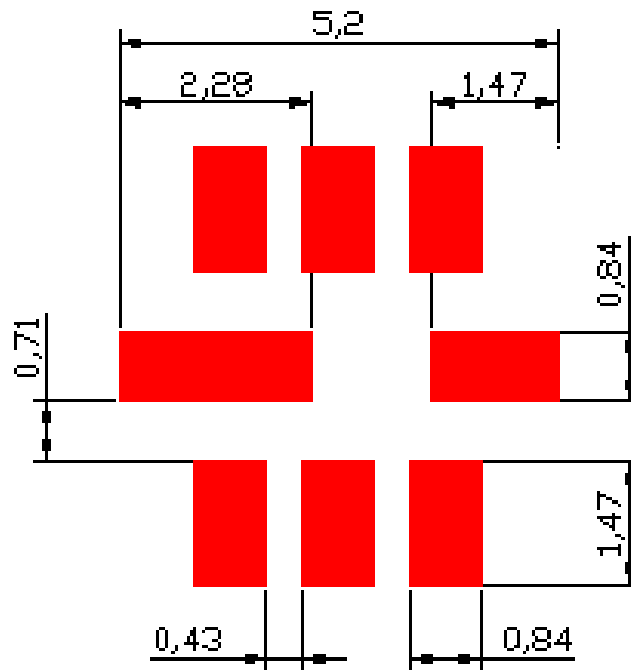

I. PACKING:

1. REEL DIMENSION



2. TAPE DIMENSION

