



UBV45

NPN SILICON TRANSISTOR

HIGH VOLTAGE FAST SWITCHING NPN POWER APPLICATIONS

DESCRIPTION

The device is manufactured using High Voltage Multi Epitaxial Planar technology for high switching speeds and high voltage capability.

The UTC **UBV45** is designed for use in Compact Fluorescent Lamps.

FEATURES

- * High Voltage Capability
- * Low Spread of Dynamic Parameters
- * Very High Switching Speed

ORDERING INFORMATION

Ordering Number		Package	Pin Assignment			Packing
Lead Free Plating	Halogen Free		1	2	3	
UBV45L-T92-B	UBV45G-T92-B	TO-92	E	C	B	Tape Box
UBV45L-T92-K	UBV45G-T92-K	TO-92	E	C	B	Bulk

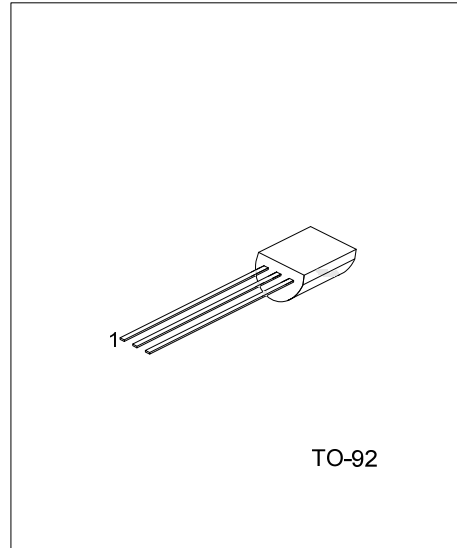

<p>UBV45L-T92-B</p> <p>(1)Packing Type</p> <p>(2)Package Type</p> <p>(3)Lead Free</p>	<p>(1) B: Tape Box, K: Bulk</p> <p>(2) T92: TO-92</p> <p>(3) L: Lead Free, G: Halogen Free</p>
---	--

UBV45

NPN SILICON TRANSISTOR

■ ABSOLUTE MAXIMUM RATINGS (Ta = 25°C)

PARAMETER	SYMBOL	RATINGS	UNIT
Collector Emitter Voltage (V _{BE} = 0)	V _{CES}	700	V
Collector Emitter Voltage (I _B = 0)	V _{CEO}	400	V
Emitter Base Voltage (I _C = 0)	V _{EBO}	9	V
Collector Current	I _C	0.75	A
Collector Peak Current (t _p < 5 ms)	I _{CM}	1.5	A
Base Current	I _B	0.4	A
Base Peak Current (t _p < 5 ms)	I _{BM}	0.75	A
Total Dissipation at Ta = 25°C	P _D	0.95	W
Junction Temperature	T _J	+150	°C
Storage Temperature	T _{STG}	-40 ~ +150	°C

Note: Absolute maximum ratings are those values beyond which the device could be permanently damaged. Absolute maximum ratings are stress ratings only and functional device operation is not implied.

■ THERMAL DATA

PARAMETER	SYMBOL	RATINGS	UNIT
Thermal Resistance Junction-ambient	θ _{JA}	130	°C/W

■ ELECTRICAL CHARACTERISTICS (Ta = 25°C, unless otherwise specified)

PARAMETER	SYMBOL	TEST CONDITIONS	MIN	TYP	MAX	UNIT
Collector Emitter Sustaining Voltage (I _B = 0) (Note)	V _{CEO(SUS)}	I _C = 1 mA	400			V
Collector Emitter Saturation Voltage (Note)	V _{CE(SAT)}	I _C = 0.2 A, I _B = 40 mA		0.2	0.5	V
		I _C = 0.3 A, I _B = 75 mA		0.3	1	
		I _C = 0.4 A, I _B = 135 mA		0.4	1.5	
Base Emitter Saturation Voltage (Note)	V _{BE(SAT)}	I _C = 0.2 A, I _B = 40 mA			1	V
		I _C = 0.3 A, I _B = 75 mA			1.2	
Emitter Cut off Current (I _C = 0)	I _{EBO}	V _{EB} = 9 V			1	mA
Collector Cut off Current (V _{BE} = -1.5V)	I _{CEV}	V _{CE} = 700 V			250	μA
DC Current Gain	h _{FE} *	I _C = 0.2 A, V _{CE} = 5 V	12		27	
		I _C = 0.4 A, V _{CE} = 5 V	7		20	
Inductive Load Fall Time	t _F	I _C = 0.2 A, V _{CLAMP} = 300 V I _{B1} = -I _{B2} = 40 mA, L = 3 mH		0.3		μs

Note: Pulsed: Pulse duration = 300μs, duty cycle = 1.5 %

■ INDUCTIVE LOAD SWITCHING TEST CIRCUIT

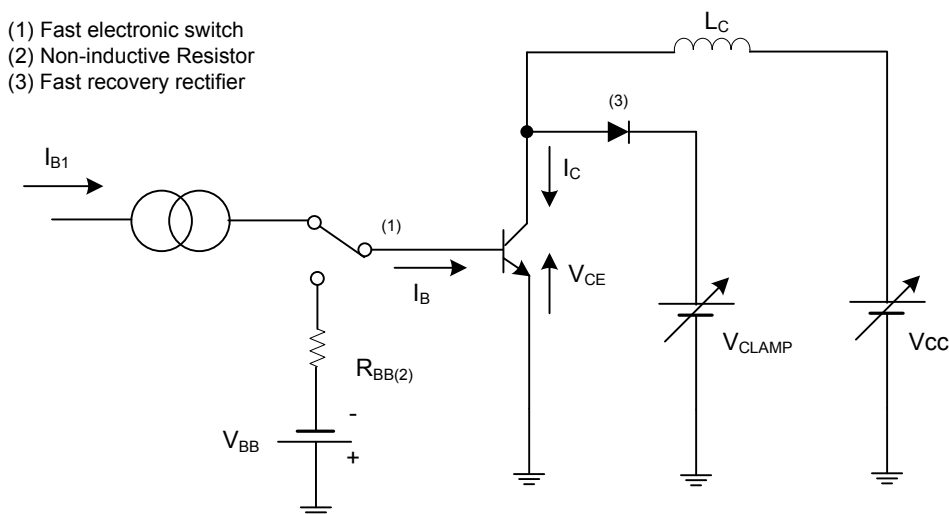

TYPICAL CHARACTERISTICS

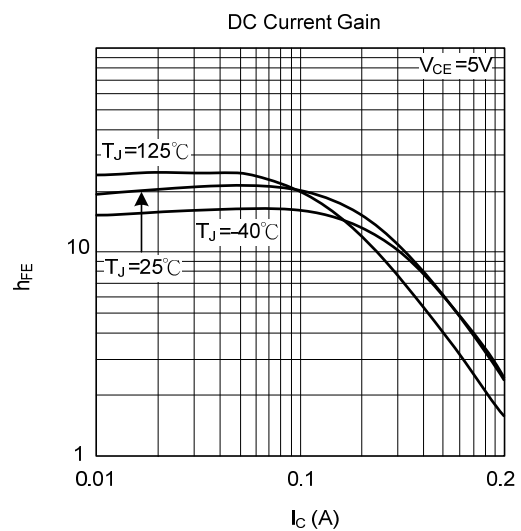
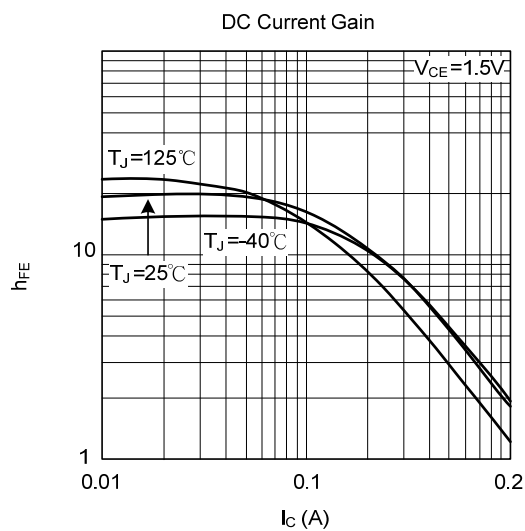
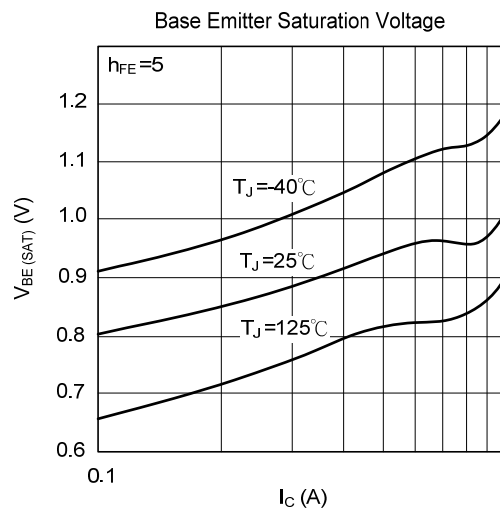
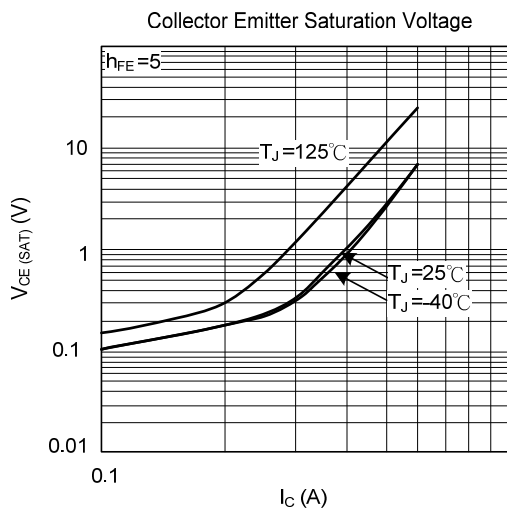
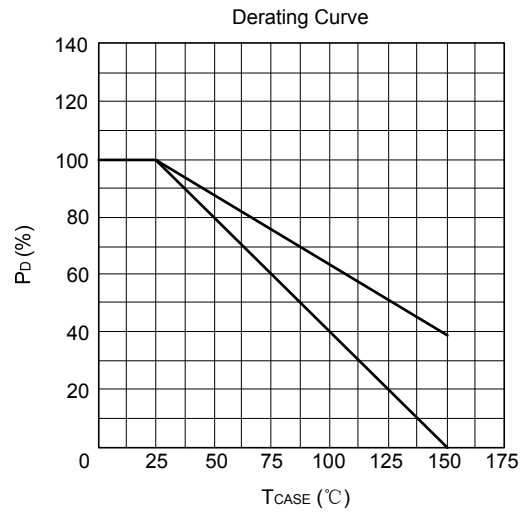
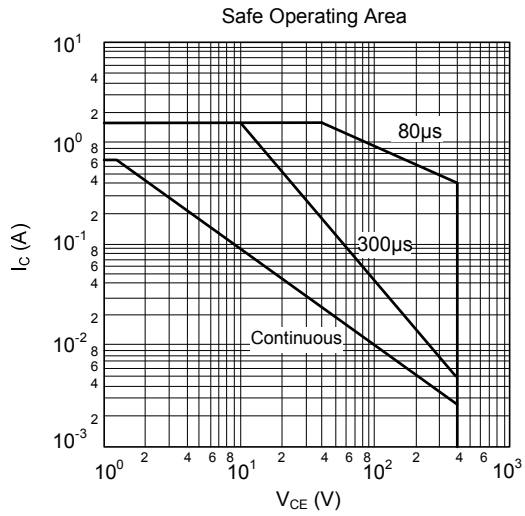

UTC assumes no responsibility for equipment failures that result from using products at values that exceed, even momentarily, rated values (such as maximum ratings, operating condition ranges, or other parameters) listed in products specifications of any and all UTC products described or contained herein. UTC products are not designed for use in life support appliances, devices or systems where malfunction of these products can be reasonably expected to result in personal injury. Reproduction in whole or in part is prohibited without the prior written consent of the copyright owner. The information presented in this document does not form part of any quotation or contract, is believed to be accurate and reliable and may be changed without notice.