

# SILICON ABRUPT VARACTOR DIODE

**DESCRIPTION:**

The **AT12020-21** is Designed for High Performance RF and Microwave Applications Requiring an Abrupt Variable Capacitance Characteristic.

**FEATURES INCLUDE:**

- High Tuning Ratio,  $\Delta C_T = 10$  MIN.
- High Quality Factor,  $Q = 300$  MIN.
- Hermetic Package,  $C_p = .20$  pF  
 $L_s = .42$  nH

**MAXIMUM RATINGS**

$I_F$	200 mA
$V_R$	120 V
$P_{DISS}$	1.75W @ $T_C$ 25 °C
$T_J$	-55 °C to +150 °C
$T_{STG}$	-55 °C to +150 °C
$\theta_{JC}$	70 °C/W

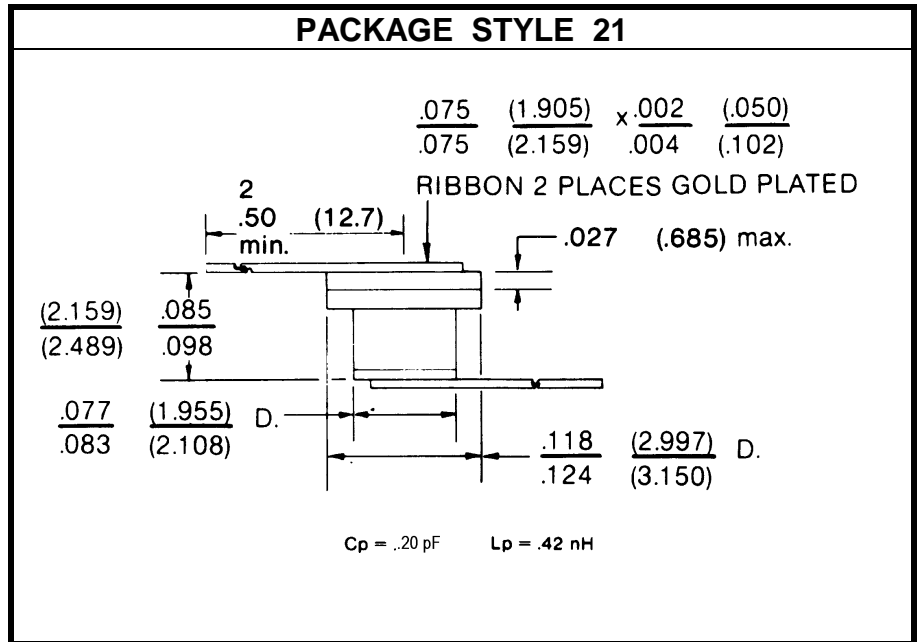
**CHARACTERISTICS**  $T_C = 25$  °C

SYMBOL	TEST CONDITIONS	MINIMUM	TYPICAL	MAXIM	UNITS
$V_R$	$I_R = 10$ $\mu$ A	120			V
$V_F$	$I_F = 1$ mA			1.0	V
$I_R$	$V_R = 100$ V			100	$\mu$ A
$C_T$	$V_R = 4$ V f = 1.0 MHz	36	38	40	pF
$\Delta C_T$	$C_{T0} / C_{T120}$ f = 1.0 MHz	10.0			---
$Q$	$V_R = 4$ V f = 50 MHz	300			---
$R_S$	$I_F = 10$ mA f = 2400 MHz			0.9	$\Omega$