

OPTICAL THERMOCOUPLE TEMPERATURE TRANSMITTER

Transmitter is a thermocouple temperature transmitter used for measuring various kinds of fluids. The electronics unit is provided with a micro-processor for digital processing of signals to realize high accuracy and intelligent measurements.

The adoption of fiber optic cable for the signal transmission line configures an optical field instrumentation system with an optical star coupler and a master station.

The transmitter is ϕ 6mm optical fiber cable connection type.

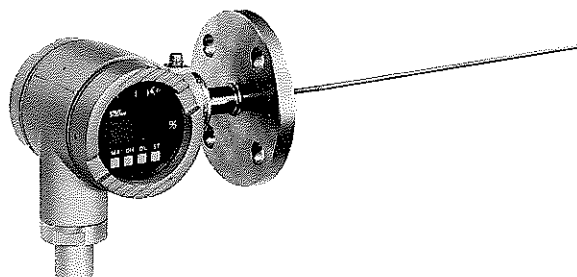

SPECIFICATIONS

Functional specifications

Fluids measured: Liquid, gas, steam, etc.

Measuring range:

Type	Measuring range [°C]	Span [°C]	Range limit [°C]	
			Lower range limit	Upper range limit
FUK1 to 3	0 to 300	100 to 300	0	300

Operating pressure:

Flange type... Less than nominal pressure of flange

Thread type... Less than 3.9MPa (40 kgf/cm²)

Output:

Linear output (optical digital output), or 2-point/3-segmented-line compensation at maximum span

Power source:

Built-in lithium battery (Life; About 2 years)

Setting:

Item	Remote setting	Direct setting
Setting item	1. Measuring range 2. Damping constant ^(*) 3. Transmitter memory read/write	1. Measuring range 2. Damping constant ^(*)
Setting equipment	HHC ^(**) or MS ^(**)	Indicating unit (option)

Notes: ^(*) Adjustable range of damping constant; 0.2 to 51.2 sec

^(**) HHC; Hand held communicator (Model FXL)

MS; Master station (Model PMH)

(See "System block diagram")

Zero elevation and suppression:

From 0°C to \pm 90% of the upper range limit

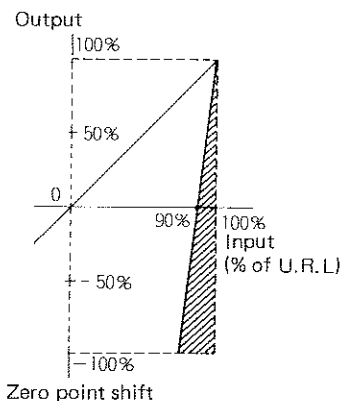

Self-diagnosis: Displayed on indicating unit (option) or HHC and transmitted to master station.

Diagnosis item	HHC, MS	Indicating unit
Measuring range abnormal	○	○
Detecting unit failure	○	○
Battery voltage low	○	○
Battery voltage	○	-
Amplifier ambient temperature	○	-

Explosion-proof: Intrinsic safety

(safety barriers are not needed under application)

Approval authority	Standard	Classification
RIIS (Japan)	JIS	i3nG5
FM (USA)	NEC, ANSI	Class I Div. 1 Group A, B, C, D Class II Div. 1 Group E, G Class III
BASEEFA (UK)	CENELEC	EEx ibIIC T4

Ambient temperature:

-30 to +60°C

Storage temperature:

-30 to +70°C

Ambient humidity:

0 to 95% RH

Transmission: Half-duplex bidirectional transmission with one-fiber system
 Transmission distance: 1.2 km (max.)
 (Free from effects of noise and surge)

Indication of measured value:
 0 to 100% or actual scale (Not for zero elevation and suppression), LCD 4-digit

Other:
 Optical receiving converter (Model PRN) is available (transmission distance; up to 4km)

Performance specifications

(1) Detecting unit (JIS C 1602-1981, J, E, K thermocouple, 0.75 class)
Accuracy rating: ±2.5°C, or ±0.75% of measured temperature whichever greater
Response time: Protective tube, φ 4.8 mm...about 8 sec
 Protective tube, φ 12 mm...about 70 sec

(2) Electronics unit
Accuracy rating: Max. of ±0.25% under reference conditions (inclusive of conformity*, hysteresis*, and repeatability*)
 When a 2-point/3-segmented-line compensation is provided, ±0.25%...at maximum measurement span

Temperature effect:
 Zero point shift between 0 to 60°C at maximum span: ±0.5% or less

Construction and material

Material of protective tube:
 S; SUS304TB
 W; SUS316TB

Finish color: Epoxy-polyurethane double coat, silver (Amplifier case cover...blue)

Enclosure: Meets JIS C0920, immersion-proof (IEC IP65 or NEMA4)

Electronics unit dimensions (H x W x D) and mass(weight) of electronics unit:
 123 x 122 x 123mm, approx. 1.5kg

Mounting method:
 Thread type; G3/4B (PF3/4), R3/4 (PT3/4), 3/4-14NPT
 Flange type; JIS10K-25A RF
 JIS20K-25A RF
 JIS30K-25A RF
 JIS63K-25A RF
 ANSI 150LB, 1 inch
 ANSI 300LB, 1 inch
 ANSI 600LB, 1 inch

Insertion length: 100 to 2000 mm
 For details, refer to "Code symbols".

Minimum bending radius:
 Sheath type (φ 4.8 mm) only...14.4 mm

Cable and connection:
 Optical cable per Fuji spec. (separately available)
 Connection: optical connector

Optional specifications

Indicating unit: Indicator...LCD 4-digit
 Setter...Pushbutton switches (four)
 (Operating temperature range: -20 to +60°C)

Scope of delivery

Instrument (main unit)

CODE SYMBOLS

Description												
Measuring span												
Measuring span [°C] Thermocouple												
100 to 300 J thermocouple												
100 to 300 E thermocouple												
100 to 300 K thermocouple												
Protective tube [mm]												
φ 12												
φ 4.8 (sheath type)												
Material of protective tube												
SUS304 (Not for 5th digit B)												
SUS316												
Indicating unit and φ 6mm optical cable adapter												
Indicating unit Protective adapter												
A X X												
B ○ (0.0 to 100.0% indication) X												
C X ○												
D ○ (0.0 to 100.0% indication) ○												
E ○ (Actual digital scale indication) X												
F ○ (Actual digital scale indication) ○												
Note: The φ 9 mm optical cable connection type is manufacturable at option.												
Mounting method												
0 Flange type JIS 10K - 25A RF												
1 Flange type JIS 20K - 25A RF												
2 Flange type JIS 30K - 25A RF												
3 Flange type JIS 63K - 25A RF												
4 Thread G3/4B (PF3/4)												
5 Thread R3/4 (PT3/4)												
6 Thread 3/4 - 14NPT												
7 Flange ANSI 150LB, 1 inch												
8 Flange ANSI 300LB, 1 inch												
9 Flange ANSI 600LB, 1 inch												
Z Other												
Output												
A Optical digital signal												
C Optical digital signal, with 2-point/3-segmented-line compensation (Not for 4th digit 2)												
Explosion-proof												
0 General type (non-explosion-proof)												
1 Intrinsic safety explosion-proof, JIS i3nG5												
5 Intrinsic safety explosion-proof FM												
7 Intrinsic safety explosion-proof BASEEFA												
Insertion length [mm]												
01 100												
02 200												
03 300												
04 400												
05 500												
06 600												
07 700												
08 800												
09 900												
10 1000												
11 1100												
12 1200												
13 1300												
14 1400												
15 1500												
16 1600												
17 1700												
18 1800												
19 1900												
20 2000												
Note: Protective tube φ12mm: Up to 1300 mm												

Note: * Technical terms are defined by ANSI S51.1 and JEMIS 022-1983

OPERATING PRINCIPLE DIAGRAM

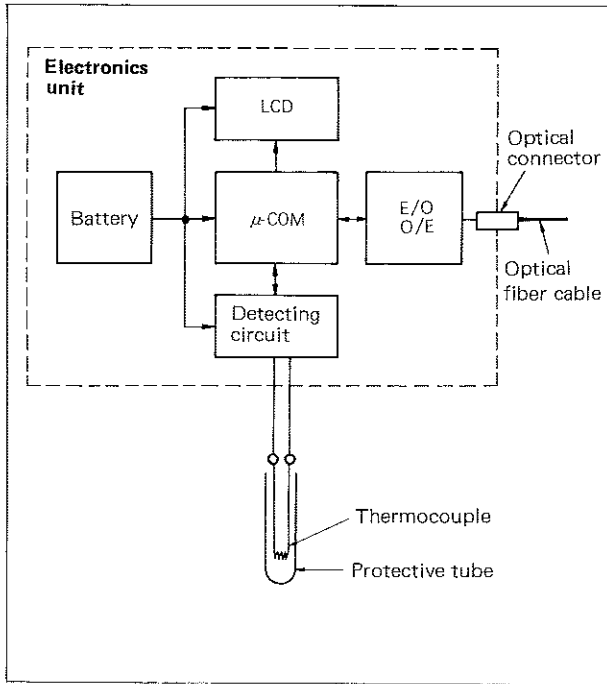

SYSTEM BLOCK DIAGRAM

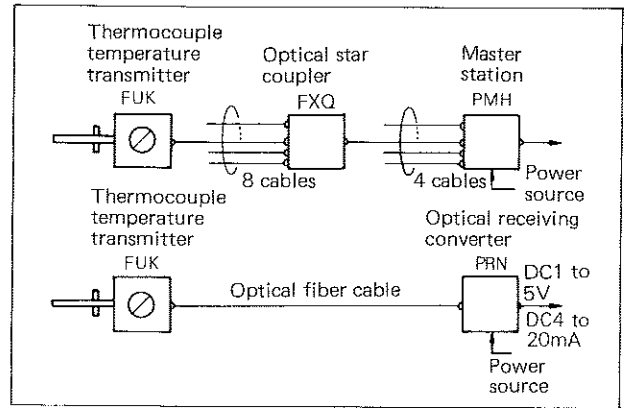

OUTLINE DIAGRAM (Unit:mm)

- Thread type

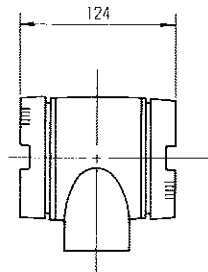

5th digit of code symbols	φ gmm
A	12
B	4.8 (sheath type)

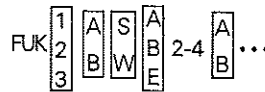
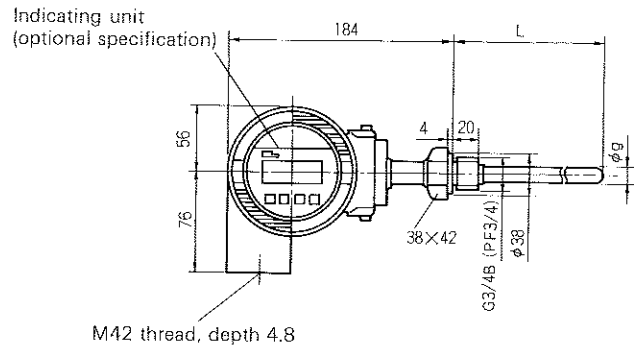

With optical cable protective adapter

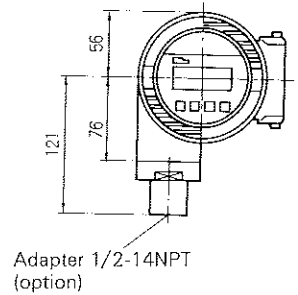

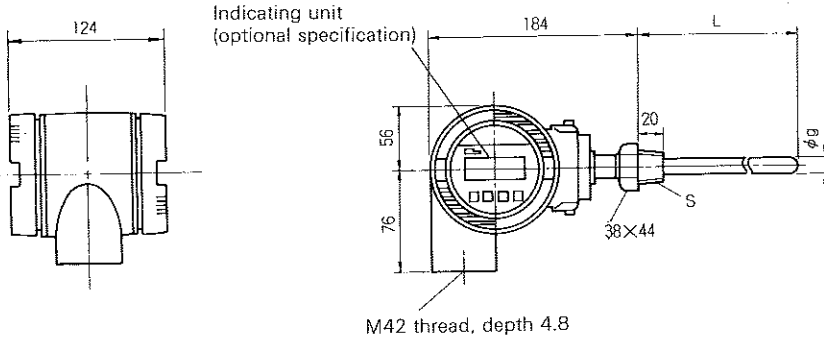

9th digit of code symbol	S
5	R3/4 (PT3/4)
6	3/4 - 14NPT

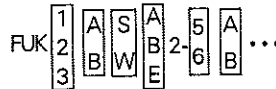

With optical cable protective adapter

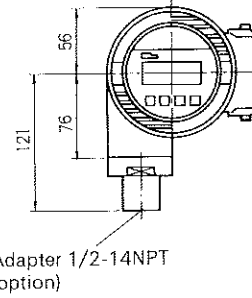

• flange type

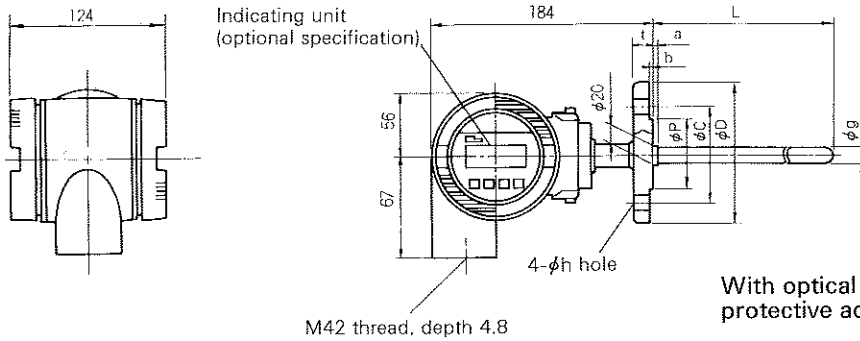

Flange	φ D	φ C	φ P	t	a	b	φ h
JIS - 10K - 25ARF	125	90	70	14	3	1	19
JIS - 20K - 25ARF	125	90	70	16	3	1	19
JIS - 30K - 25ARF	130	95	70	20	3	1	19
JIS - 63K - 25ARF	140	100	70	27	3	1	23
ANSI 150LB, 1 inch	108	79.4	50.8	14.5	3	1.6	16
ANSI 300LB, 1 inch	124	88.9	50.8	17.5	3	1.6	20
ANSI 600LB, 1 inch	124	88.9	50.8	17.5	3	1.6	20

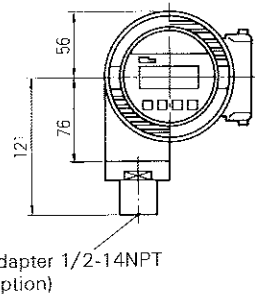

5th digit of code symbol	φ gmm
A	12
B	4.8 (sheath type)

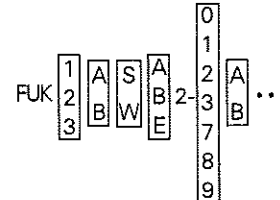

RELATED DEVICES

- Master station (EDS11-86, EDS11-121)
- Optical receiving converter (EDS9-43)
- Optical star coupler (EDS8-48)
- HHC (EDS8-44)
- Connector assembling tool
- Optical connector
- Cable

ORDERING INFORMATION

1. Measuring item or application
2. Name of product
3. Complete model number
4. Operating pressure and measuring range
5. Material of measuring unit
6. Special specifications if necessary
7. Other engineering data if necessary

Fuji Electric Co.,Ltd.

Head office
 12-1 Yurakucho 1-chome, Chiyoda-ku, Tokyo, 100 Japan
 Phone: Tokyo 3211-7111
 Telex: J22331 FUJIELEA or FUJIELEB

Instrumentation & Control Div.
 No.1, Fuji-machi, Hino-city, Tokyo 191 Japan
 Phone: 0425-85-6200
 Fax: 0425-85-6188