

# DRA100 SERIES

AC - DC DIN RAIL MOUNTABLE POWER SUPPLY  
INDUSTRIAL CONTROL EQUIPMENT



## FEATURES

- UNIVERSAL INPUT 90~264VAC
- SHORT CIRCUIT PROTECTION
- INTERNAL INPUT FILTER
- 2 YEARS WARRANTY



## SELECTION CHART

**DRA 100 - 24 x**

Wattage | A : SCREW TERMINALS  
12 : 12V OUT / 24 : 24V OUT / 48 : 48V OUT | AL : CLASS 2 POWER (24V ONLY)

## MODEL LIST

MODEL NO.	INPUT VOLTAGE	OUTPUT WATTAGE	OUTPUT VOLTAGE	OUTPUT CURRENT	EFF. (min.)	EFF. (typ.)
<b>Single Output Models</b>						
DRA100-12A	90 ~264 VAC	100.8 WATTS	+ 12 VDC	8400 mA	82%	84%
DRA100-24A	90 ~264 VAC	100.8 WATTS	+ 24 VDC	4200 mA	84%	86%
DRA100-24AL	90 ~264 VAC	91.2 WATTS	+ 24 VDC	3800 mA	83%	85%
DRA100-48A	90 ~264 VAC	100.8 WATTS	+ 48 VDC	2100 mA	86%	88%

## SPECIFICATION

All Specifications Typical At Nominal Line, Full Load, 25°C Unless Otherwise Noticed

GENERAL						
Characteristics	Conditions		min.	typ.	max.	unit
Switching frequency	Vi nom, Io nom		45		60	KHz
Isolation voltage	Input-Output		3000 / 4242			VAC / VDC
	Input-FG		1500 / 2121			VAC / VDC
Isolation resistance	Input-Output, @ 500VDC		100			MΩ
Ambient temperature	Operating at Vi nom		-35		+ 71	°C
Derating (see derating curve)	Vi nom, from +61 to +71°C				2.5	% / °C
Storage temperature	Non operational		-40		+ 85	°C
Relative humidity	Vi nom, Io nom		20		95	% RH
Temperature coefficient	Vi nom, Io min				± 0.03	% / °C
MTBF	Bellcore Issue 6 @40°C, GB	12V model		448000		Hours
		24V model		456000		Hours
		24AL model		493000		Hours
		48V model		490000		Hours
Altitude during operation	IEC 60068-2-13				4850	m
Dimension	Screw terminal type		L90 x W54 x D114			mm
Cooling	Free air convection					
Pollution degree			2			

## SPECIFICATION

All Specifications Typical At Nominal Line, Full Load, 25°C Unless Otherwise Noticed

### INPUT SPECIFICATIONS

Characteristics	Conditions		min.	typ.	max.	unit
Rated input voltage	Io nom		100		240	VAC
Absolute input max. range	Ta min ... Ta max, Io nom	AC in	90		264	VAC
		DC in	120		375	VDC
Input current	Vi : 115 / 230 VAC, Io nom			1.65 / 0.83		A
Rated input current	Vi : 90 VAC, Io nom				2.4	A
Line frequency	Vi nom, Io nom		47		63	Hz
Inrush current	Vi : 115 / 230 VAC , Io nom				30 / 60	A
Power dissipation	Vi : 230 VAC, Io nom	12V model		18.5		W
		24V model		15		W
		24AL model		14		W
		48V model		14		W
Leakage current	Input-Output				0.25	mA
	Input-FG				3.5	mA

### OUTPUT SPECIFICATIONS

Characteristics	Conditions		min.	typ.	max.	unit
Output voltage accuracy (Adjusted before shipment)	Vi nom, Io max		0		+ 1	%
Minimum load	Vi nom		0			%
Line regulation	Io nom, Vi min ...Vi max				± 1	%
Load regulation	Vi nom, Io min ...Io nom	single mode			± 1	%
		parallel mode			± 5	%
Voltage trim range	Vi nom, 0.8 Io nom	12V model	11.4		14.5	VDC
		24V model	22.5		28.5	VDC
		24AL model	22.5		24.5	VDC
		48V model	47		56	VDC
Rated continuous loading	Vi nom	12V model	8.4 A @ 12Vdc / 6.9 A @ 14.5 Vdc			
		24V model	4.2 A @ 24Vdc / 3.5 A @ 28.5 Vdc			
		24AL model	3.8 A @ 24Vdc / 3.7 A @ 24.5 Vdc			
		48V model	2.1 A @ 48Vdc / 1.8 A @ 56 Vdc			
Hold up time	Vi : 115 / 230 VAC , Io nom		15 / 30			ms
Turn on time	Vi nom, Io nom				1000	ms
	Vi nom, Io nom → 12V, 24V models : with 7000µF CAP 48V model : with 3500µF CAP				1500	ms
Rise time	Vi nom, Io nom				150	ms
	Vi nom, Io nom → 12V, 24V models : with 7000µF CAP 48V model : with 3500µF CAP				500	ms
Fall time	Vi nom, Io nom				150	ms
Transient recovery time	Vi nom, I ~ 0.5 Io nom				2	ms
Ripple & noise	Vi nom, Io nom, BW = 20MHz				50	mV
Power back immunity	Vi nom, Io nom	12V model	18			VDC
		24V model	35			VDC
		24AL model	35			VDC
		48V model	63			VDC
Capacitor load	Vi nom, Io nom	12V, 24V models			7000	µF
		48V model			3500	µF
DC ON indicator threshold at start up (Green LED)	Vi nom, Io nom	12V model	10		11.2	VDC
		24V model	17.6		19.4	VDC
		48V model	37		43	VDC
DC LOW indicator threshold after start up (Red LED)	Vi nom, Io nom	12V model	10		11.2	VDC
		24V model	17.6		19.4	VDC
		48V model	37		43	VDC
Parallel operation	0.1 Io min ~ 0.9 Io max (Except 24AL model)				3	unit
Efficiency	Vi nom, Io nom, Po / Pi		Up to 88%, See model list and typ efficiency curve			

## SPECIFICATION

All Specifications Typical At Nominal Line, Full Load, 25°C Unless Otherwise Noticed

### CONTROL AND PROTECTION

Characteristics	Conditions	min.	typ.	max.	unit
Input fuse		T3.15A / 250VAC internal			
Internal surge voltage protection	IEC 61000-4-5	Varistor			
Rated over load protection	Vi nom (see typ current limited curve)	110		140	%
	24AL model	102		108	%
Power Rdy (for 24V model only)	Threshold voltage of contact closed(at start up)	17.6		19.4	VDC
	Electrical isolation	500			VDC
	Contact rating at 60VDC			0.3	A
Over voltage protection	Vi nom, Io nom (Auto Recovery)	12V model	14.5	17.4	VDC
		24V model	30	33	VDC
		24AL model	24.5	25.5	VDC
		48V model	60	66	VDC
Output short circuit		Fold forward			
Degree of protection		IP20			

### APPROVALS AND STANDARDS

UL / cUL	UL 508 Listed UL 60950-1, UL 1310 Class 2 Power (24AL model only) Recognized
TUV	EN 60950-1, CB scheme EN 61558-1, EN 61558-2-17 (meet EN 60204-1)
CE	EN 61000-6-3, EN 55022 Class B, EN 61000-3-2, EN 61000-3-3 EN 61000-6-2, EN 55024, EN 61000-4-2 Level 4, EN 61000-4-3 Level 3 EN 61000-4-4 Level 4, EN 61000-4-5 L-N Level 3, L / N-FG Level 4 EN 61000-4-6 Level 3, EN 61000-4-8 Level 4, EN 61000-4-11 ENV 50204 Level 2, EN 61204-3
Vibration resistance	meet IEC 60068-2-6 (Mounting by rail : 10-500 Hz, 2G, along X, Y, Z each Axis, 60 min for each Axis )
Shock resistance	meet IEC 60068-2-27 (15G, 11ms, 3 Axis, 6 Faces, 3 times for each Face)

### PHYSICAL CHARACTERISTICS

Case size	90 x 54 x 114 mm (3.6 x 2.13 x 4.49 inches)
Case material	Plastic
Weight	430g
Packing	0.51kg ; 32pcs / 17.5kg / 1.85CUFT

### MECHANISM & PIN CONFIGURATION

mm [inch]

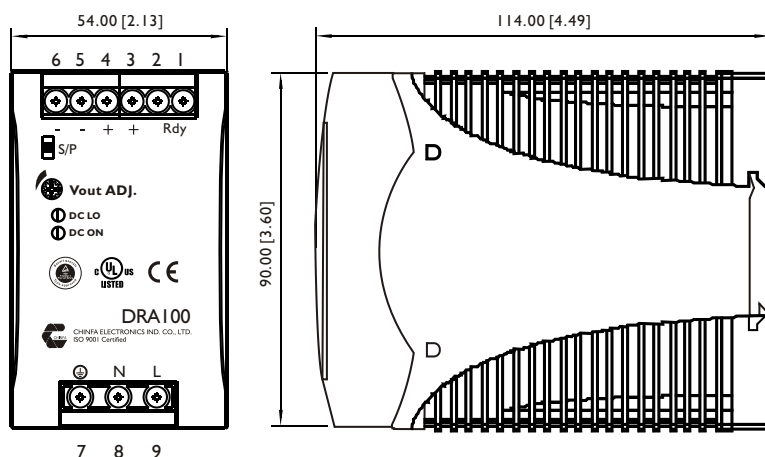

#### CONSTRUCTION

Easy snap-on mounting onto the DIN-Rail (TS35/7.5 or TS35/15), unit sits safely and firmly on the rail.

#### INSTALLATION

Ventilation / Cooling  
Normal convection  
All sides 25mm free space  
For cooling recommended  
Connector size range  
AWG24-10 (0.2~4mm<sup>2</sup>) flexible / solid cable,  
-Input connector can withstand torque at maximum 9 pound-inches.  
-Output connector can withstand torque at maximum 5.5 pound-inches.  
8 m/m stripping at cable end recommends  
Use copper conductors only, 60 / 75°C

#### GENERAL TOLERANCE

0.00[0.00] - 30.00[1.18]	±0.30[0.01]
30.00[1.18] - 120.00[4.72]	±0.50[0.02]

## PIN ASSIGNMENT

PIN NO.	Designation	Description
1	OUT	RDY
2		A normal open relay contact for DC ON level control (Never connect except 24AL model)
3, 4		V +
5, 6		V -
7	IN	⊕
8		N
9		L
	OTHER	DC ON
		DC LO
		Vout ADJ.
		S / P

## CIRCUIT SCHEMATIC

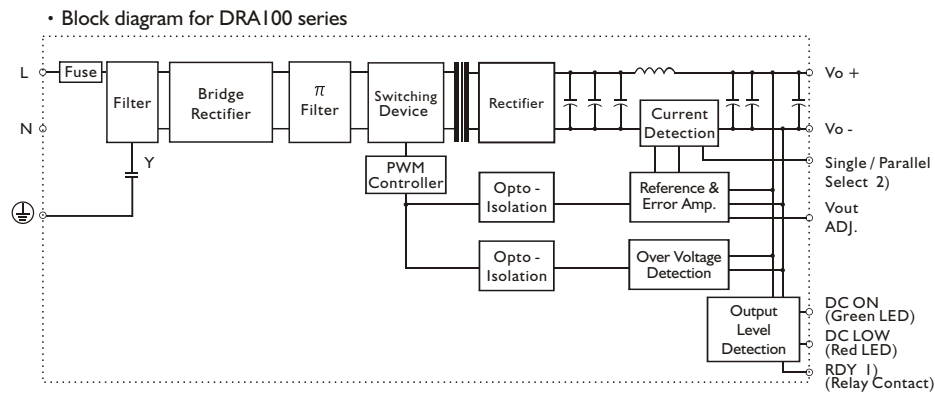

## TYP. CURRENT LIMITED CURVE

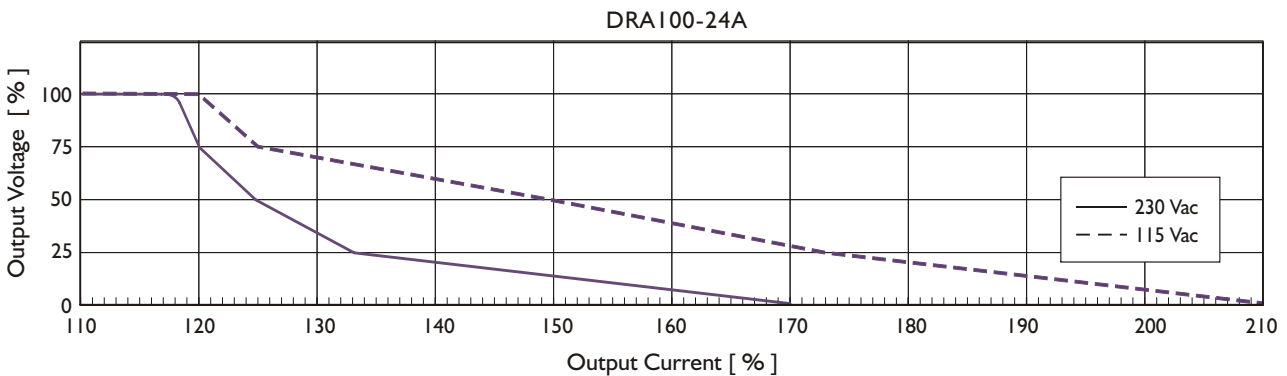

## DERATING CURVE

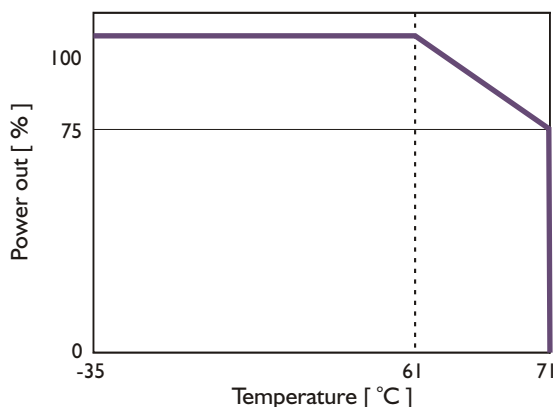

## TYP. EFFICIENCY CURVE

