

LX1971 EVALUATION BOARD USER'S GUIDE

LX1971 VISIBLE LIGHT SENSOR



TABLE OF CONTENTS

Overview3
 Features
 Operation

TABLES
Evaluation Board Connections 4
Jumper Explanation..... 4
Test Point Descriptions..... 4

FIGURES
LX1971 Evaluation Board Component List..... 5
LX1971 Evaluation Board Silk Screen & PCB Traces..... 5
LX1971 Evaluation Board Schematic 6

OVERVIEW

The LX1971 is a new technology light sensor with spectral response that emulates the human eye. This device is ideal for monitoring ambient light for the control of artificial lighting, operation of shades, LED signage and display, street lighting, automotive light sensors and control of backlight dimming. It has a unique photo diode arrangement (patents pending) with a peak response at 520nm while sharply attenuating both ultra violet and infrared wavelengths without the use of an optical filter.

The evaluation board ships with an aperture wheel that allows the user to approximate the sensor's mounting inside an assembly with an entrance hole for light. The aperture wheel can rotate to program various holes sizes. Three small rheostats and four input connection terminals permit the sensor's output gain (current to voltage conversion) and dimming transfer function to be adjusted to the user's ambient light conditions, and output voltage requirements.

For a quick demonstration of the dimming capability of the sensor the evaluation board can be configured (by setting J1 to the LED Driver position, and J4 to the Driver position) to power two white LED's by a Microsemi LX1990 LED sink driver controller (included) when 3 to 5V is connected across VDD and GND terminals.

Evaluation Board Features

- Aperture wheel allows simulation of sensor mounting inside a case
- Included rheostats allows easy output voltage gain conversion for light level
- Additional jumpers enable isolation, and pull-down diodes for some configurations
- Included LX1990 Sink LED Driver and two Microsemi white LED's demonstrate the sensors utility and ease of use

EVALUATION BOARD OPERATION

The evaluation board has five possible inputs of which at least two must be used to operate the circuit. In the simplest configuration connect 3V to 5V across VDD and GND. With this power connected and all jumpers in their open position (see evaluation board schematic figure 2) the LX1971 by itself can be evaluated. The SRC

and SNK outputs will act as a current source and sink respectively and change with the intensity of light. The output compliance range will of course depend on the input voltage and output current (see LX1971 datasheet for details).

If the light sensors current outputs are to be used directly, then the SRC and SNK terminals can be used to hook up external circuitry to the sensor. If however the application requires conversion of the output currents to a scalable voltage output, then J2 and/or J4 should be used. Jumper J2 when set to the DIVIDER position connects the SRC output to external resistors. When jumper J4 is connected in the SNK PULL-UP position then the SNK output current can be pulled up to VDD or some lower external voltage. Jumper J3 when in the D2 IN position inserts an isolation diode in series with the divider string for applications where the sensor may be disengaged for full manual override. This could be true if power to the sensors is interrupted, or the SRC diode pull-down terminal is set low shunting the sensors output current.

The SRC ADJUST PULL-UP terminal allows an external DC voltage or PWM signal to connect to the high side of the voltage divider R1+R2 and R4+R5. Rheostats R1 and R4 allow easy adjustment of the divider; they are set to their maximum (100K Ω) when set fully clockwise.

The SRC FIXED PULL-UP terminal provides a second input for a DC voltage or PWM signal for more complex signal conditioning circuits. The terminal labeled SRC DIODE PULL-DOWN can be used as described above to shunt the sensors current; this too could be a DC voltage or PWM signal.

On the SNK side the evaluation board includes one 100K Ω rheostat, R6 that can be connected to VDD to generate a signal inverted from the SRC output side. On both the SRC and SNK output a 1 μ f capacitor (C1 & C3) is placed in parallel with the output resistors. The capacitors slow down the response time of the sensor so it won't try to track the 50-60Hz lighting. All evaluation board input connections; jumpers and test points are summarized in table 1-3 on the following page. See LX1971 datasheet for application schematics and suggestions.

Input	Allowable Range	Description
VDD	3 to 5.5V	LX1971 power supply if J1 is set to LX1971 only, or LX1971 power supply and LX1990 and external LED's power supply if J1 is connected to LED DRIVER (LED's will only light if J4 is also in DRIVER position).
GND	0V	Common ground reference
SRC Diode Pull-down	5V to GND, fixed DC voltage or PWM/Logic signal	This diode connection is generally used to shunt SRC output current when disengaging the sensor in a full manual mode
SRC Adjust Pull-up	5V to GND, fixed DC voltage or PWM/Logic signal	First pull-up connection is generally used to set a minimum output voltage or adjust output transfer slope for SRC pin
SRC Fixed Pull-up	5V to GND, fixed DC voltage or PWM/Logic signal	Second pull-up connection is generally used to set a minimum output voltage or adjust output transfer slope for SRC pin
SNK Pull-up	5V to GND, fixed DC voltage or PWM/Logic signal	This pull-up connection is generally used to set a maximum output voltage or adjust output transfer slope for SNK pin

Table 1 – Evaluation Board Terminals

Jumper	Function
J1	Jumper to LED Driver connects LX1990 driver IC & LX1971 to VDD, Jumper to LX1971 only connects VDD to the LX1971 sensor only.
J2	Jumper to SRC open disconnects external divider circuitry from LX1971 SRC pin. Jumper to DIVIDER connects external divider circuitry to SRC pin.
J3	Shorts or leaves connect the series diode D2 from SRC pull-down path
J4	Jumper to DRIVER connects the SNK output to the ISET input of the LX1990 through a 4.12K resistor. Jumper to SNK Pull-up connects the SNK pin to the SNK Pull-up external board connection

Table 2 – Jumper Explanation

Test Point	Description
GND	Common Ground Reference
VDD	VDD Input to LX1971 (3 to 5.5V)
SNK	LX1971 SNK output
SRC	LX1971 SRC output
SRC Diode Pull-down	Cathode of diode connected to SRC pin
SRC Adjust Pull-up	100K rheostat and series 10K resistor to SRC
SRC Fixed Pull-up	50K series resistor to SRC
SNK Pull-up	100K rheostat and parallel 1 μ F capacitor to SNK

Table 3 – Terminal/Test Point Descriptions

LX1971 EVALUATION BOARD COMPONENT LIST

MISCELLANEOUS COMPONENTS

Part Description	Manufacturer & Part #	Reference Designators	Qty
IC, Sensor	MICROSEMI LX1971ILM	U1	1
IC, Controller	MICROSEMI LX1990I	U2	1
Diodes	VARIOUS 1N4148	D1,D2	2
LEDs, WHITE Bright	Microsemi UPWLED470A Optomite or equivalent	LED1 , LED2	2
Terminals/Probe Standoffs		Various	9

CAPACITORS

Part Description	Manufacturer & Part #	Reference Designators	Qty
Capacitor, X7R, 100nF, 50V, 10%	Any	C2	1
Capacitor, X7R, 1uF, 50V, 10%	Any	C1, C2	2

RESISTORS

Part Description	Manufacturer & Part #	Reference Designators	Qty
Resistor, Pot Thumbwheel 100K	Any	R1,R2,R6	3
Resistor, 4.12K, 1%, 1/16W	Any	R7	1
Resistor, 10K, 1%, 1/16W	Any	R1,R5	2
Resistor, 50.0K, 1%, 1/16W	Any	R3	1

LX1971 EVALUATION BOARD SILKSCREEN & PCB TRACES*

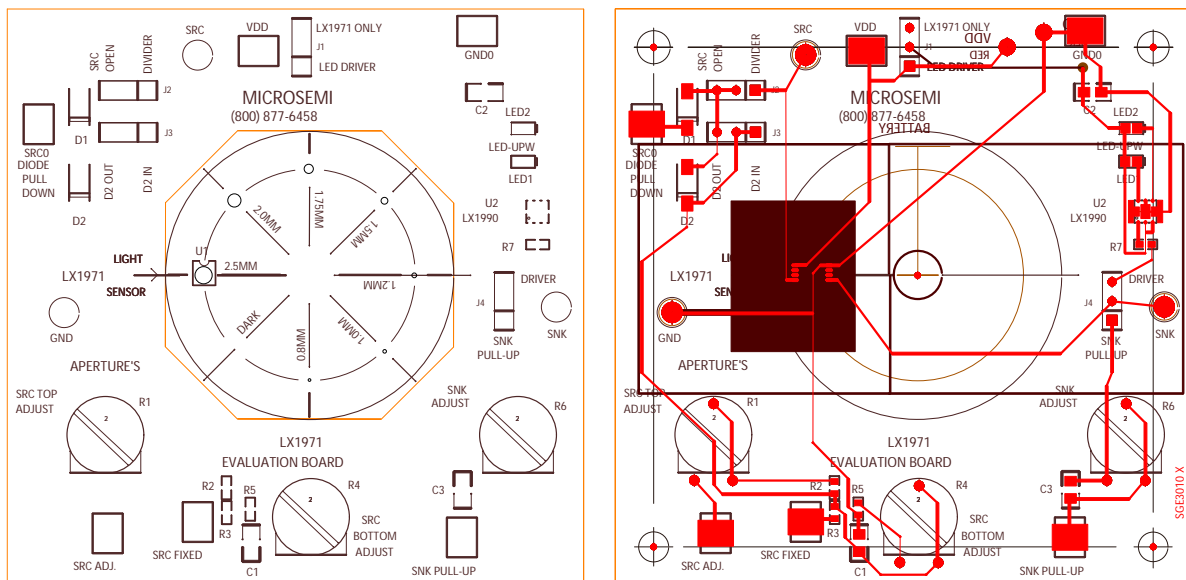

Figure 1

* The LX1971 Evaluation Board shares the same PCB as the LX1970 Evaluation Board. Although the PCB silkscreen may read LX1970, an additional label should indicate that the board is indeed a LX1971 Evaluation Board and that the LX1971 Visible Light Sensor has been mounted in the sensor position.

LX1971 EVALUATION BOARD SCHEMATIC

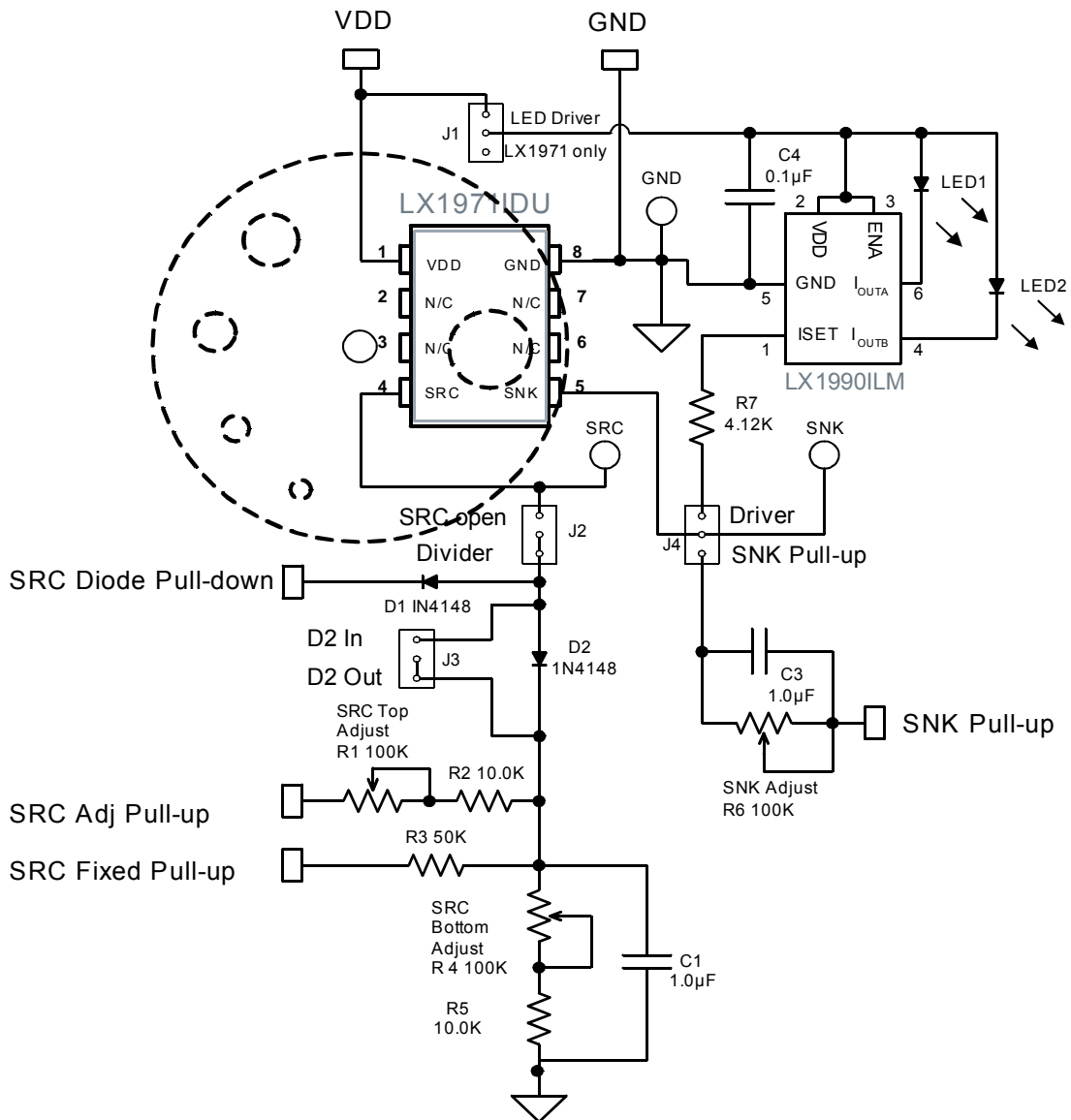

Figure 2 – Schematic