

Surface Mount Miniature Trimmers Single-Turn Cermet Fully Sealed

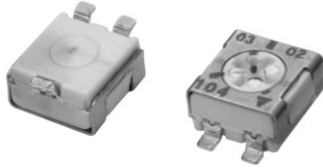

The TS5 trimming potentiometer has been designed for surface mount applications and offers volumetric efficiency (5 x 5 x 2.7 mm) with high performance and stability.

The TS5 design is suitable for both manual or automatic operation, and can withstand wave and reflow soldering techniques.

DIMENSIONS in millimeters

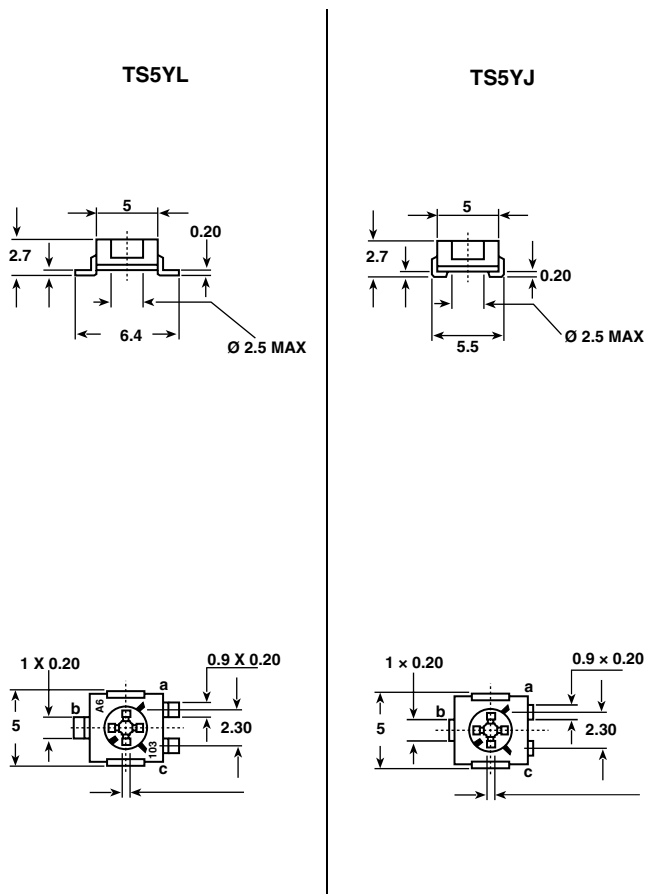

cruciform screwdriver slot
 \varnothing 2.5, width 0.5
 deep: 0.55
 max deep (center): 0.7

FEATURES

- 0.25 W at 70 °C
- CECC 41100
- GAM T1
- Professional grade
- Wide ohmic range (10 Ω to 1 M Ω)
- Full sealing
- Low contact resistance variation (1 % or 3 Ω)
- Small size for optimum packing density
- Suitable for both manual or automatic operation



RECOMMENDED SOLDERING AREAS

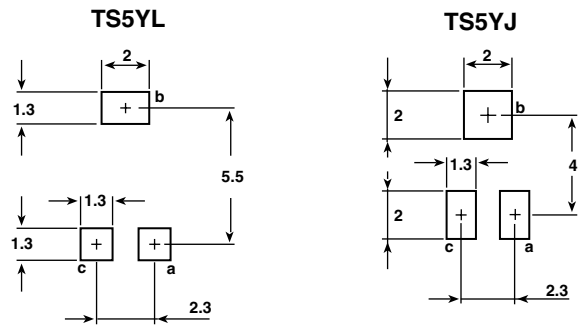

ADHESIVE PAD (detail)

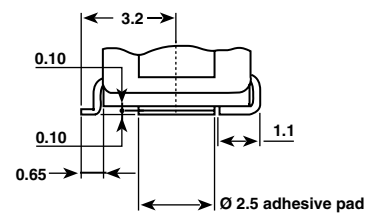

CIRCUIT DIAGRAM

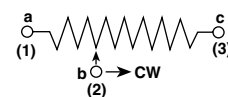

Tolerance unless otherwise specified \pm 0.25 mm



ELECTRICAL SPECIFICATIONS		
Resistive Element		Cermet
Electrical Travel		220° ± 15°
Resistance Range		10 Ω to 1 MΩ
Standard Series		1 - 2 - 5
Tolerance Standard		± 10 %
Power Rating	Linear	0.25 W at 70 °C
	Logarithmic	not applicable
Temperature Coefficient		See Standard Resistance Element Data
Limiting Element Voltage (Linear Law)		200 V
Contact Resistance Variation		1 % or 3 Ω
End Resistance (Typical)		0.1 % or 3 Ω
Dielectric Strength (RMS)		1000 V
Insulation Resistance		1 GΩ
Specification		in accordance with CECC 41100

MECHANICAL SPECIFICATIONS

Mechanical Travel	270° ± 10°
Operating Torque (max. Ncm)	1.5
End Stop Torque (max. Ncm)	3.5
Unit Weight (max. g)	0.15

ENVIRONMENTAL SPECIFICATIONS

Temperature Range	- 55 °C to + 125 °C
Climatic Category	55/125/56
Sealing	fully sealed container solder immersion IP67

POWER RATING CHART

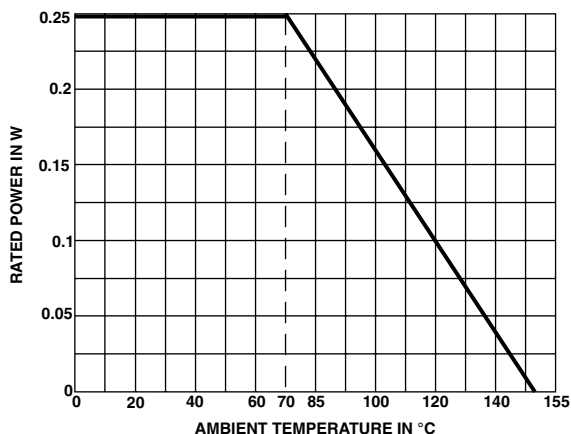

PERFORMANCE			
TESTS	CONDITIONS	TYPICAL VALUES AND DRIFTS	
		$\frac{\Delta RT}{RT}$ (%)	$\frac{\Delta R_{1-2}}{R_{1-2}}$ (%)
Load Life	1000 hours at rated power 90°/30' - ambient temperature + 70 °C	± 2 %	± 3 % Contact resistance variation: $\Delta R < 1 \% R_n$
Climatic Sequence	Phase A dry heat 125 °C Phase B damp heat Phase C cold - 55 °C Phase D damp heat 5 cycles	± 2 %	± 3 %
Long Term Damp Heat	Temperature 40 °C - RH 93 % 56 days	± 2 %	± 3 % Dielectric strength: 1000 V RMS Insulation resistance: > 10 ⁴ MΩ
Thermal Shock	55 °C to + 125 °C - 5 cycles	± 1 %	$\frac{\Delta V_{1-2}}{V_{1-3}} \leq \pm 2 \%$
Rotational Life (Electrical and Mechanical)	100 cycles - rated power	± (3 % + 5 Ω)	
Shock	50 g - 11 ms 3 successive shocks in 3 directions	± 1 %	$\frac{\Delta V_{1-2}}{V_{1-3}} \leq \pm 1 \%$
Vibration	10 - 55 Hz 0.75 mm or 10 g - 6 hours	± 1 %	$\frac{\Delta V_{1-2}}{V_{1-3}} \leq \pm 1 \%$



Surface Mount Miniature Trimmers
Single-Turn Cermet Fully Sealed

Vishay Sfernice

STANDARD RESISTANCE ELEMENT DATA				
STANDARD RESISTANCE VALUES	LINEAR LAW			TYPICAL TCR - 55 °C + 125 °C
	MAX. POWER AT 70 °C	MAX. WORKING VOLTAGE	MAX. CUR. THROUGH ELEMENT	
Ω	W	V	mA	ppm/°C
10	0.25	1.58	158	± 100
20	↓	2.24	112	
50100		3.545.00	7150	
200		7.07	35	
500		11.2	22	
1K		15.8	16	
2K		22.4	11	
5K		35.4	7	
10K		50.0	5	
20K		70.7	3.5	
50K		112	2.2	
100K	0.25	158	1.6	
200K	0.20	200	1.0	
500K	0.08	200	0.4	
1M	0.04	200	0.2	

MARKING (RED MARK)

VISHAY trademark, ohmic value, manufacturing date, red mark.

The ohmic value is indicated by a 3 figure code, the first two are significant figures, the third one is the multiplier.

Example: 100 = 10 Ω
101 = 100 Ω
102 = 1000 Ω
503 = 50 000 Ω

SOLDERING RECOMMENDATIONS

see Application notes

PACKAGING

On tape and reel of 500 pieces, code TR and 2000 pieces, code TR1

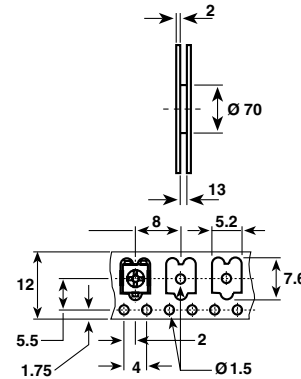
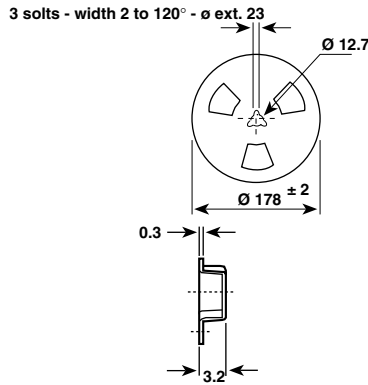

Cover tape panel strength specifications EIA 481 A and CEI 60286-3.

ORDERING INFORMATION

TS5	YL	500 kΩ	± 10 %	TR500	e3
SERIES	STYLE	OHMIC VALUE	TOLERANCE	PACKAGING	LEAD FINISH

TR: Tape and reel 500 pcs
TR1: Tape and reel 2000 pcs
e3: pure Sn

SAP PART NUMBERING GUIDELINES

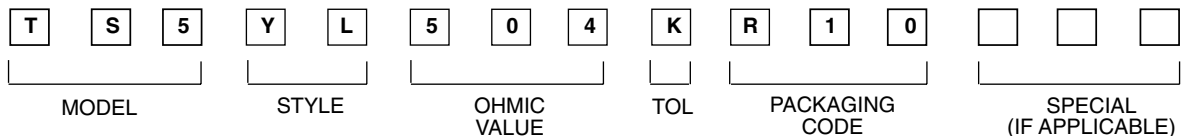

See the end of this data book for conversion tables



Disclaimer

All product specifications and data are subject to change without notice.

Vishay Intertechnology, Inc., its affiliates, agents, and employees, and all persons acting on its or their behalf (collectively, "Vishay"), disclaim any and all liability for any errors, inaccuracies or incompleteness contained herein or in any other disclosure relating to any product.

Vishay disclaims any and all liability arising out of the use or application of any product described herein or of any information provided herein to the maximum extent permitted by law. The product specifications do not expand or otherwise modify Vishay's terms and conditions of purchase, including but not limited to the warranty expressed therein, which apply to these products.

No license, express or implied, by estoppel or otherwise, to any intellectual property rights is granted by this document or by any conduct of Vishay.

The products shown herein are not designed for use in medical, life-saving, or life-sustaining applications unless otherwise expressly indicated. Customers using or selling Vishay products not expressly indicated for use in such applications do so entirely at their own risk and agree to fully indemnify Vishay for any damages arising or resulting from such use or sale. Please contact authorized Vishay personnel to obtain written terms and conditions regarding products designed for such applications.

Product names and markings noted herein may be trademarks of their respective owners.