

WD1935A

Features

Offers compatibility with many current communications standards, such as HDLC, SDLC, ADCCP, CCITT X.25 and ISDN

Includes SDLC loop data link capability

Provides data transmission speeds to 4.0 Mbps

Allows error checking for CRC, underrun, overrun, aborted or invalid frame errors

Contains extendable address/control field

Performs automatic zero insertion and deletion

Uses single +5 volt power source

40 pin dual-in-line or leaded chip carrier for SMT

Provides enhanced DMA capability/EOB option

Allows variable character length and residual character capability

Offers programmable modem control interrupts and NRZI encode/decode

Description

The WD1935A is a programmable Synchronous Data Link Controller that facilitates the easy design of interfaces between a parallel digital system and a serial data communication channel and vice versa. This controller is capable of full and half duplex operation and is

particularly suited to high speed applications.

The 1935A is an NMOS/LSI device designed for bit-oriented SDLC, HDLC and other bit synchronous protocols. It is designed to be particularly efficient when used in DMA applications.

Applications include: computer to terminal communications, computer to modem interfacing, front end communications, message and packet switching, protocol converters, and communication test equipment.

The WD1935A is compatible with most eight bit microcomputers and can be connected directly to a microcomputer bus.

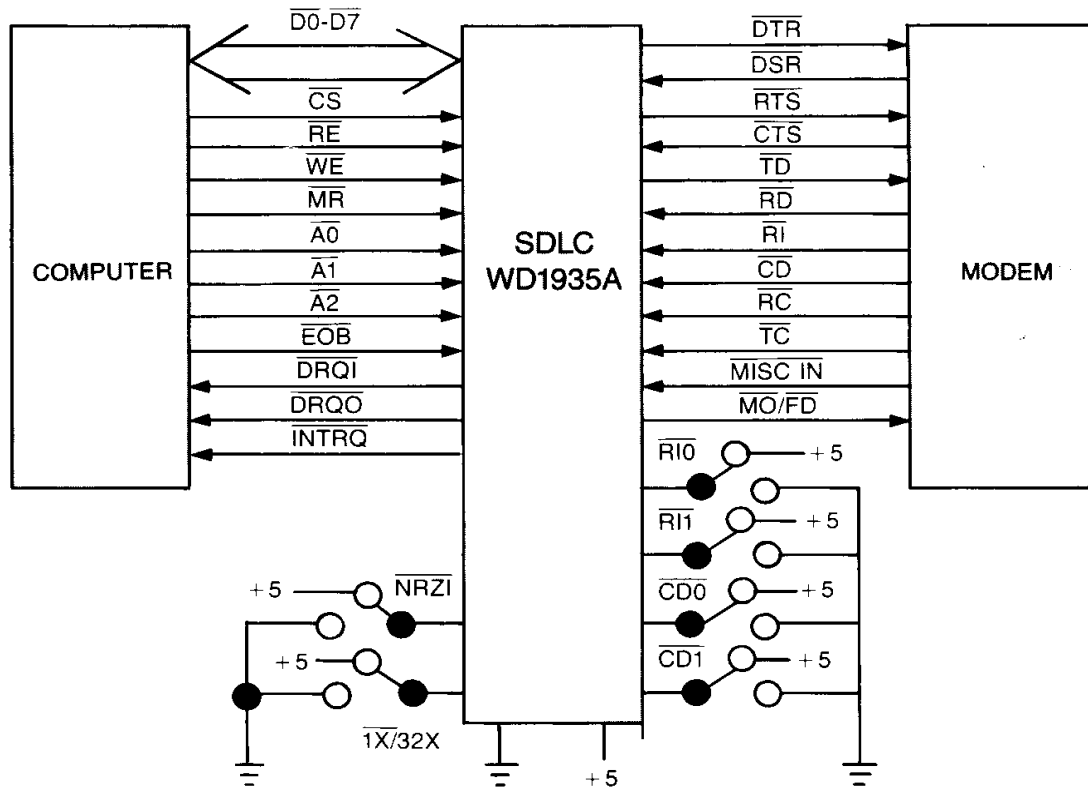

WD1935A TYPICAL SYSTEM INTERFACE

