

RECOMMENDED P.C. BOARD HOLE LAYOUT

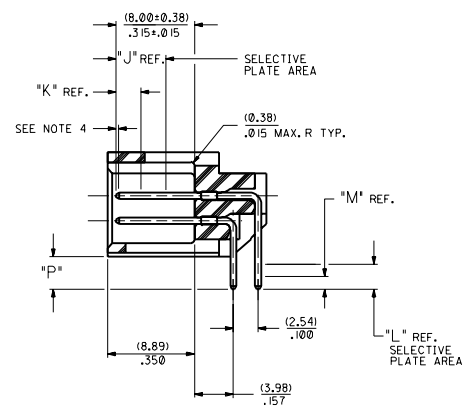

SECTION J-J

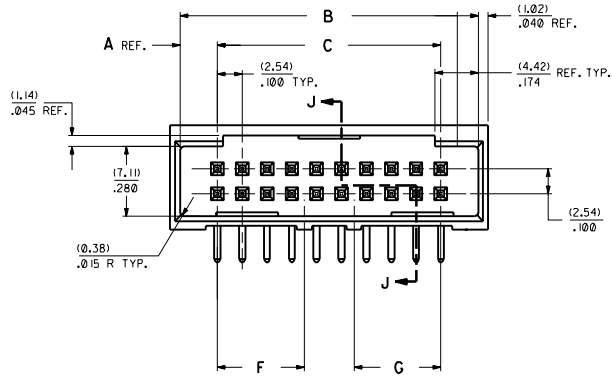
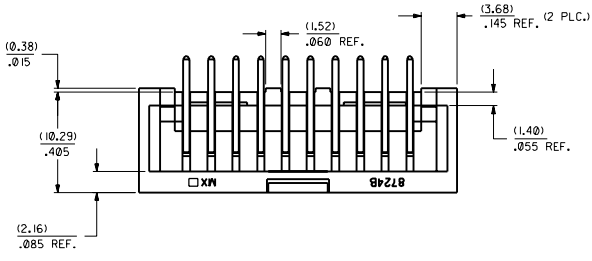
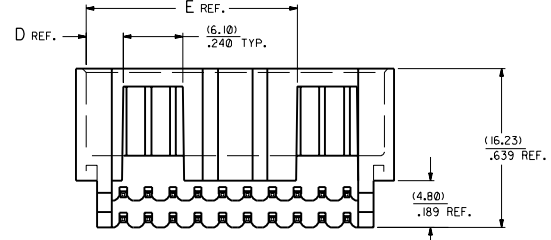

CKT.	8724							
	DIM. 'A'	DIM. 'B'	DIM. 'C'	DIM. 'D'	DIM. 'E'	DIM. 'F'	DIM. 'G'	DIM. 'H'
06	(3.81) .150	(12.70) .500	(5.08) .200	(3.81) .150				(10.46) .412
08	(3.81) .150	(15.24) .600	(7.62) .300	(3.81) .150				(13.00) .512
10	(3.81) .150	(17.78) .700	(10.16) .400	(6.35) .250				(15.54) .612
12	(3.81) .150	(20.32) .800	(12.70) .500	(6.35) .250				(18.08) .712
14	(3.81) .150	(22.86) .900	(15.24) .600	(8.89) .350				(20.62) .812
16	(3.81) .150	(25.40) 1.000	(17.78) .900	(8.89) .350				(23.16) .912
18	(3.81) .150	(27.94) 1.100	(20.32) .800	(11.43) .450				(25.70) 1.012
20	(3.81) .150	(30.48) 1.200	(22.86) .900	(3.81) .150	(21.59) .850			(28.24) 1.112
22	(3.81) .150	(33.02) 1.300	(25.40) 1.000	(3.81) .150	(24.13) .950			(30.78) 1.212
24	(3.81) .150	(35.56) 1.400	(27.94) 1.100	(3.81) .150	(26.67) 1.050	(16.64) .655		(33.32) 1.312
26	(3.81) .150	(38.10) 1.500	(30.48) 1.200	(3.81) .150	(29.21) 1.150	(16.64) .655		(35.86) 1.412
28	(3.81) .150	(40.64) 1.600	(33.02) 1.300	(3.81) .150	(31.75) 1.250	(16.64) .655		(38.40) 1.512
30	(3.81) .150	(43.18) 1.700	(35.56) 1.400	(3.81) .150	(34.29) 1.350	(16.64) .655		(40.94) 1.612
32	(3.81) .150	(45.72) 1.800	(38.10) 1.500	(3.81) .150	(36.83) 1.450	(16.64) .655		(43.48) 1.712
34	(3.81) .150	(48.26) 1.900	(40.64) 1.600	(3.81) .150	(39.37) 1.550	(16.64) .655	(16.76) .660	(46.02) 1.812
36	(3.81) .150	(50.80) 2.000	(43.18) 1.700	(3.81) .150	(41.91) 1.650	(16.64) .655	(16.76) .660	(48.56) 1.912
38	(3.81) .150	(53.34) 2.100	(45.72) 1.800	(3.81) .150	(44.45) 1.750	(16.64) .655	(16.76) .660	(51.10) 2.012
40	(3.81) .150	(55.88) 2.200	(48.26) 1.900	(3.81) .150	(46.99) 1.850	(16.64) .655	(16.76) .660	(53.64) 2.112
42	(3.81) .150	(58.42) 2.300	(50.80) 2.000	(3.81) .150	(49.53) 1.950	(16.64) .655	(16.76) .660	(56.18) 2.212
44	(3.81) .150	(60.96) 2.400	(53.34) 2.100	(3.81) .150	(52.07) 2.050	(16.64) .655	(16.76) .660	(58.72) 2.312
46	(3.81) .150	(63.50) 2.500	(55.88) 2.200	(3.81) .150	(54.61) 2.150	(19.05) .750	(16.76) .660	(61.26) 2.412
48	(3.81) .150	(66.04) 2.600	(58.42) 2.300	(3.81) .150	(57.15) 2.250	(19.05) .750	(16.76) .660	(63.80) 2.512
50	(3.81) .150	(68.58) 2.700	(60.96) 2.400	(3.81) .150	(59.69) 2.350	(19.05) .750	(16.76) .660	(66.34) 2.612
52	(3.81) .150	(71.12) 2.800	(63.50) 2.500	(3.81) .150	(62.23) 2.450	(19.05) .750	(16.76) .660	(68.88) 2.712
54	(3.81) .150	(73.66) 2.900	(66.04) 2.600	(3.81) .150	(64.77) 2.550	(21.59) .850	(21.84) .860	(71.42) 2.812
56	(3.81) .150	(76.20) 3.000	(68.58) 2.700	(3.81) .150	(67.31) 2.650	(21.59) .850	(21.84) .860	(73.96) 2.912
58	(3.81) .150	(78.74) 3.100	(71.12) 2.800	(3.81) .150	(69.85) 2.750	(21.84) .860	(26.92) 1.060	(76.50) 3.012
60	(3.81) .150	(81.28) 3.200	(73.66) 2.900	(3.81) .150	(72.39) 2.850	(21.84) .860	(26.92) 1.060	(79.04) 3.112
62	(3.81) .150	(83.82) 3.300	(76.20) 3.000	(3.81) .150	(74.93) 2.950	(21.84) .860	(26.92) 1.060	(81.58) 3.212
64	(3.81) .150	(86.36) 3.400	(78.74) 3.100	(3.81) .150	(77.47) 3.050	(21.84) .860	(26.92) 1.060	(84.12) 3.312
66	(3.81) .150	(88.90) 3.500	(81.28) 3.200	(3.81) .150	(80.01) 3.150	(21.84) .860	(26.92) 1.060	(86.66) 3.412
68	(3.81) .150	(91.44) 3.600	(83.82) 3.300	(3.81) .150	(82.55) 3.250	(21.84) .860	(26.92) 1.060	(89.20) 3.512
70	(3.81) .150	(93.98) 3.700	(86.36) 3.400	(3.81) .150	(85.09) 3.350	(21.84) .860	(26.92) 1.060	(91.74) 3.612
72	(3.81) .150	(96.52) 3.800	(88.90) 3.500	(3.81) .150	(87.63) 3.450	(21.84) .860	(26.92) 1.060	(94.28) 3.712

NOTES:

- 1- 20 CIRCUIT SIZE SHOWN FOR ILLUSTRATION PURPOSES.
- 2- PIN PUSHOUT FORCE: (11.79 N) 1/4 LBS.
- 3- PINS MUST MEET SOLDERABILITY SPEC. MIL-STD-202 METHOD 208B.
- 4- ROW TO ROW PIN HEIGHT VARIATION MUST NOT EXCEED (0.13) / .005 IN.
- 5- FOR CHARTED DIMENSIONS AND ASSEMBLY NOS. NOT SHOWN ON THIS SHEET - SEE SHEET 4.
- 6- WINDOW NOT AVAILABLE ON 6 CIRCUIT.

MATERIAL:

SHROUDED WAFER: GLASS FILLED NYLON, COLOR: BLACK, UL94 V-0.
PINS: PHOSPHOR BRONZE, SEE SHEET 4 FOR FINISHES.

ASSEMBLY STYLES "C" & "D"

DIMENSIONS SHOWN METRIC INCH		REVISE ONLY ON CAD SYSTEM	
TITLE: SALES ASSEMBLY		REV: 0	
SUBTITLE: WAFER - RIGHT ANGLE FULLY SHROUDED		DATE: 06/26/86	
GRID: .100		PART NO. 8724	
MATERIAL: NYLON 6/6		DRAWN BY: JLB	
MATERIAL: PHOSPHOR BRONZE		CHECKED BY: RB	
MATERIAL: NYLON 6/6		SCALE: 4:1	
MATERIAL: NYLON 6/6		SEE CHART SDA-8724-*****	
MATERIAL: NYLON 6/6		MFG. CODE: 8724	

20	19	18	17	16	15	14	13	12	11	8724	9	8	7	6	8724	4	3	2	1
ENGINEERING PART NUMBER A-8724-	RELEASE FOR MANUFACTURE	P REF.	PLATING (SEE NOTES ON THIS SHEET)	CONNECTOR END PLATING			P.C. BOARD END PLATING			PACKAGING INFORMATION									
				TYPE	J LENGTH	K MEAS.	TYPE	L LENGTH	M MEAS.	PK-70873-									
06C164 / 72C164	RFM	(3,30) .130	TIN	TIN	_____	(2,54) .100	TIN	_____	(1,27) .050	0019									
06D164 / 72D164	RFM	(5,08) .200	TIN	TIN	_____	(2,54) .100	TIN	_____	(1,27) .050	0019									
06C571 / 72C571	RFM	(3,30) .130	15 GOLD	GOLD	(5,08) .200	(2,54) .100	TIN	(2,54) .100	(1,27) .050	0019									
06D571 / 72D571	RFM	(5,08) .200	15 GOLD	GOLD	(5,08) .200	(2,54) .100	TIN	(2,54) .100	(1,27) .050	0019									
06C574 / 72C574	RFM	(3,30) .130	30 GOLD	GOLD	(5,08) .200	(2,54) .100	TIN	(2,54) .100	(1,27) .050	0019									
06D574 / 72D574	RFM	(5,08) .200	30 GOLD	GOLD	(5,08) .200	(2,54) .100	TIN	(2,54) .100	(1,27) .050	0019									

PLATING FINISHES:

TIN TIN (Sn) OVER ENTIRE PIN;
THICKNESS=(3.75 MICROMETER)/75 MICROINCH MINIMUM;
NICKEL (Ni) UNDERPLATE OVER ENTIRE PIN.

15 GOLD SELECTIVE GOLD (Au) IN THE CONTACT AREA;
THICKNESS=(0.37 MICROMETER)/15 MICROINCH MINIMUM;
SELECTIVE TIN (Sn) IN THE PC TAIL AREA;
THICKNESS=(1.88 MICROMETER)/75 MICROINCH MINIMUM;
NICKEL (Ni) UNDERPLATE OVER ENTIRE PIN.

30 GOLD SELECTIVE GOLD (Au) IN THE CONTACT AREA;
THICKNESS=(0.75 MICROMETER)/30 MICROINCH MINIMUM;
SELECTIVE TIN (Sn) IN THE PC TAIL AREA;
THICKNESS=(1.88 MICROMETER)/75 MICROINCH MINIMUM;
NICKEL (Ni) UNDERPLATE OVER ENTIRE PIN.

*THE PRIMARY SHIPPING CARTON WILL BE LABELED "COMPLIANT TO
ROHS DIRECTIVE 2002/95/EC AND ELV ANNEX II OF DIRECTIVE 2000/53/EC".
CARTONS WITHOUT THIS LABEL MAY CONTAIN PRODUCT WITH LEAD.

NO. OF CKTS	TIN		TIN		15 GOLD		15 GOLD		15 GOLD		30 GOLD									
	EDP NUMBER	ENG NUMBER	EDP NUMBER	ENG NUMBER	EDP NUMBER	ENG NUMBER	EDP NUMBER	ENG NUMBER	EDP NUMBER	ENG NUMBER	EDP NUMBER	ENG NUMBER	EDP NUMBER	ENG NUMBER	EDP NUMBER	ENG NUMBER	EDP NUMBER	ENG NUMBER	EDP NUMBER	ENG NUMBER
06	15-42-7206	A-8724-06C164	15-42-7306	A-8724-06D164	15-29-7206	A-8724-06C571	15-29-7306	A-8724-06D571	15-41-8206	A-8724-06C574	15-41-8306	A-8724-06D574								
08	15-42-7208	A-8724-08C164	15-42-7308	A-8724-08D164	15-29-7208	A-8724-08C571	15-29-7308	A-8724-08D571	15-41-8208	A-8724-08C574	15-41-8308	A-8724-08D574								
10	15-42-7210	A-8724-10C164	15-42-7310	A-8724-10D164	15-29-7210	A-8724-10C571	15-29-7310	A-8724-10D571	15-41-8210	A-8724-10C574	15-41-8310	A-8724-10D574								
12	15-42-7212	A-8724-12C164	15-42-7312	A-8724-12D164	15-29-7212	A-8724-12C571	15-29-7312	A-8724-12D571	15-41-8212	A-8724-12C574	15-41-8312	A-8724-12D574								
14	15-42-7214	A-8724-14C164	15-42-7314	A-8724-14D164	15-29-7214	A-8724-14C571	15-29-7314	A-8724-14D571	15-41-8214	A-8724-14C574	15-41-8314	A-8724-14D574								
16	15-42-7216	A-8724-16C164	15-42-7316	A-8724-16D164	15-29-7216	A-8724-16C571	15-29-7316	A-8724-16D571	15-41-8216	A-8724-16C574	15-41-8316	A-8724-16D574								
18	15-42-7218	A-8724-18C164	15-42-7318	A-8724-18D164	15-29-7218	A-8724-18C571	15-29-7318	A-8724-18D571	15-41-8218	A-8724-18C574	15-41-8318	A-8724-18D574								
20	15-42-7220	A-8724-20C164	15-42-7320	A-8724-20D164	15-29-7220	A-8724-20C571	15-29-7320	A-8724-20D571	15-41-8220	A-8724-20C574	15-41-8320	A-8724-20D574								
22	15-42-7222	A-8724-22C164	15-42-7322	A-8724-22D164	15-29-7222	A-8724-22C571	15-29-7322	A-8724-22D571	15-41-8222	A-8724-22C574	15-41-8322	A-8724-22D574								
24	15-42-7224	A-8724-24C164	15-42-7324	A-8724-24D164	15-29-7224	A-8724-24C571	15-29-7324	A-8724-24D571	15-41-8224	A-8724-24C574	15-41-8324	A-8724-24D574								
26	15-42-7226	A-8724-26C164	15-42-7326	A-8724-26D164	15-29-7226	A-8724-26C571	15-29-7326	A-8724-26D571	15-41-8226	A-8724-26C574	15-41-8326	A-8724-26D574								
28	15-42-7228	A-8724-28C164	15-42-7328	A-8724-28D164	15-29-7228	A-8724-28C571	15-29-7328	A-8724-28D571	15-41-8228	A-8724-28C574	15-41-8328	A-8724-28D574								
30	15-42-7230	A-8724-30C164	15-42-7330	A-8724-30D164	15-29-7230	A-8724-30C571	15-29-7330	A-8724-30D571	15-41-8230	A-8724-30C574	15-41-8330	A-8724-30D574								
32	15-42-7232	A-8724-32C164	15-42-7332	A-8724-32D164	15-29-7232	A-8724-32C571	15-29-7332	A-8724-32D571	15-41-8232	A-8724-32C574	15-41-8332	A-8724-32D574								
34	15-42-7234	A-8724-34C164	15-42-7334	A-8724-34D164	15-29-7234	A-8724-34C571	15-29-7334	A-8724-34D571	15-41-8234	A-8724-34C574	15-41-8334	A-8724-34D574								
36	15-42-7236	A-8724-36C164	15-42-7336	A-8724-36D164	15-29-7236	A-8724-36C571	15-29-7336	A-8724-36D571	15-41-8236	A-8724-36C574	15-41-8336	A-8724-36D574								
38	15-42-7238	A-8724-38C164	15-42-7338	A-8724-38D164	15-29-7238	A-8724-38C571	15-29-7338	A-8724-38D571	15-41-8238	A-8724-38C574	15-41-8338	A-8724-38D574								
40	15-42-7240	A-8724-40C164	15-42-7340	A-8724-40D164	15-29-7240	A-8724-40C571	15-29-7340	A-8724-40D571	15-41-8240	A-8724-40C574	15-41-8340	A-8724-40D574								
42	15-42-7242	A-8724-42C164	15-42-7342	A-8724-42D164	15-29-7242	A-8724-42C571	15-29-7342	A-8724-42D571	15-41-8242	A-8724-42C574	15-41-8342	A-8724-42D574								
44	15-42-7244	A-8724-44C164	15-42-7344	A-8724-44D164	15-29-7244	A-8724-44C571	15-29-7344	A-8724-44D571	15-41-8244	A-8724-44C574	15-41-8344	A-8724-44D574								
46	15-42-7246	A-8724-46C164	15-42-7346	A-8724-46D164	15-29-7246	A-8724-46C571	15-29-7346	A-8724-46D571	15-41-8246	A-8724-46C574	15-41-8346	A-8724-46D574								
48	15-42-7248	A-8724-48C164	15-42-7348	A-8724-48D164	15-29-7248	A-8724-48C571	15-29-7348	A-8724-48D571	15-41-8248	A-8724-48C574	15-41-8348	A-8724-48D574								
50	15-42-7250	A-8724-50C164	15-42-7350	A-8724-50D164	15-29-7250	A-8724-50C571	15-29-7350	A-8724-50D571	15-41-8250	A-8724-50C574	15-41-8350	A-8724-50D574								
52	15-42-7252	A-8724-52C164	15-42-7352	A-8724-52D164	15-29-7252	A-8724-52C571	15-29-7352	A-8724-52D571	15-41-8252	A-8724-52C574	15-41-8352	A-8724-52D574								
54	15-42-7254	A-8724-54C164	15-42-7354	A-8724-54D164	15-29-7254	A-8724-54C571	15-29-7354	A-8724-54D571	15-41-8254	A-8724-54C574	15-41-8354	A-8724-54D574								
56	15-42-7256	A-8724-56C164	15-42-7356	A-8724-56D164	15-29-7256	A-8724-56C571	15-29-7356	A-8724-56D571	15-41-8256	A-8724-56C574	15-41-8356	A-8724-56D574								
58	15-42-7258	A-8724-58C164	15-42-7358	A-8724-58D164	15-29-7258	A-8724-58C571	15-29-7358	A-8724-58D571	15-41-8258	A-8724-58C574	15-41-8358	A-8724-58D574								
60	15-42-7260	A-8724-60C164	15-42-7360	A-8724-60D164	15-29-7260	A-8724-60C571	15-29-7360	A-8724-60D571	15-41-8260	A-8724-60C574	15-41-8360	A-8724-60D574								
62	15-42-7262	A-8724-62C164	15-42-7362	A-8724-62D164	15-29-7262	A-8724-62C571	15-29-7362	A-8724-62D571	15-41-8262	A-8724-62C574	15-41-8362	A-8724-62D574								
64	15-42-7264	A-8724-64C164	15-42-7364	A-8724-64D164	15-29-7264	A-8724-64C571	15-29-7364	A-8724-64D571	15-41-8264	A-8724-64C574	15-41-8364	A-8724-64D574								
66	15-42-7266	A-8724-66C164	15-42-7366	A-8724-66D164	15-29-7266	A-8724-66C571	15-29-7366	A-8724-66D571	15-41-8266	A-8724-66C574	15-41-8366	A-8724-66D574								
68	15-42-7268	A-8724-68C164	15-42-7368	A-8724-68D164	15-29-7268	A-8724-68C571	15-29-7368	A-8724-68D571	15-41-8268	A-8724-68C574	15-41-8368	A-8724-68D574								
70	15-42-7270	A-8724-70C164	15-42-7370	A-8724-70D164	15-29-7270	A-8724-70C571	15-29-7370	A-8724-70D571	15-41-8270	A-8724-70C574	15-41-8370	A-8724-70D574								
72	15-42-7272	A-8724-72C164	15-42-7372	A-8724-72D164	15-29-7272	A-8724-72C571	15-29-7372	A-8724-72D571	15-41-8272	A-8724-72C574	15-41-8372	A-8724-72D574								

R		SEE SHEET I	DIMENSIONS SHOWN METRIC INCH		± 0		REVISE ONLY ON CAD SYSTEM	
O		SEE SHEET I	UNLESS OTHERWISE SPECIFIED		TITLE		SALES ASSEMBLY	
M		SEE SHEET I	TOLERANCES UNLESS OTHERWISE SPECIFIED		WAFER-RIGHT ANGLE FULLY SHROUDED		.100 GRID-FOR USE W/.005 SQ. PINS	
L2		SEE SHEET I	FRACTIONS		WITH .150 END WALLS		MOLEX INCORPORATED	
K		SEE SHEET I	DECIMALS		PART NO.		DATE	
LTR.		REVISIONS	SCALE		SHEET NO.		06/26/86	
LTR.		REVISIONS	SCALE		DRAWN BY		SDA-8724-*****	
LTR.		REVISIONS	SCALE		CHECKED BY		DA D	

20	19	18	17	16	15	14	13	12	11	10	9	8	7	6	5	4	3	2	1
----	----	----	----	----	----	----	----	----	----	----	---	---	---	---	---	---	---	---	---