



4-wire Resistive Touch Screen Controller



BU21049GUL

General Description

Unlike most resistive touch screen controllers, the BU21049GUL 4-wire resistive touch-screen controller generate data to enable dual touch detection. The Host processor can use data to detect single point coordinates and dual coordinates.

Features

- Enables single touch and dual touch using standard 4-wire resistive touch screen
- I2C like interface for interfacing to the host processor
- 12-bit Resolution
- Single 1.65V to 3.60V Supply.
- Power on reset
- Auto power down control
- Built-in clock oscillation circuit

Key Specifications

■ Power supply voltage	1.65V~3.6.0V
■ Temperature range	-20[°C]~85[°C]
■ Standby current	1.0uA (Max.)
■ Sleep current	100uA (Typ.)
■ Operating current	0.8mA(Typ.)
■ Coordinate resolution	12bit

Packages

VCSP50L2	2.00 mm × 2.00 mm × 0.55(max) mm
----------	----------------------------------

Applications

- Equipment with a built in the user interface of 4-wire resistive touch screen
- Portable information equipment like as Smart phone, Table, PDA.
- Audio-visual equipment like as Digital still camera, Digital video camera, portable TV.
- PC/ PC peripheral equipment like as Laptop, Touch screen monitor, printer.

Typical Application Circuits

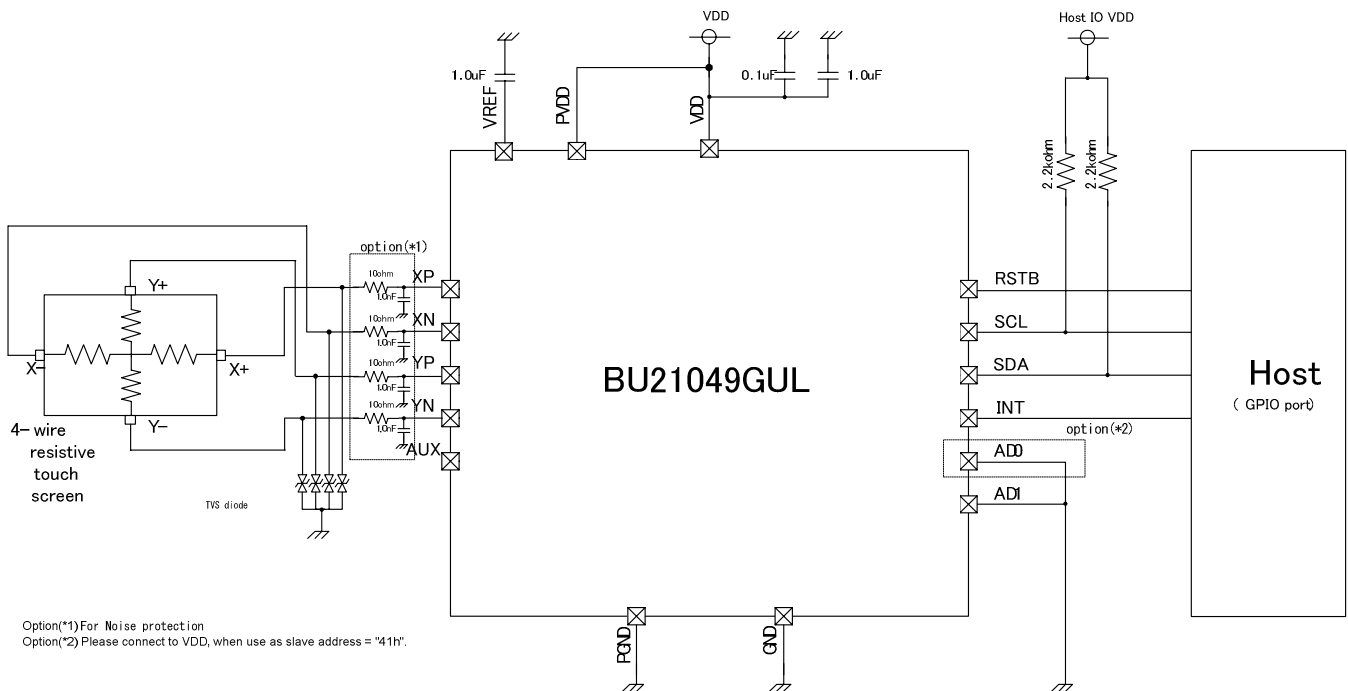

●Pin Configuration

Top View

	1	2	3	4
A	YP	XN	YN	AD0
B	XP	PGND	AD1	SDA
C	PVDD	AUX	RSTB	SCL
D	VREF	GND	VDD	INT

●Pin Description

Pin No	Pin Name	I/O	Description	Equivalent circuit
A1	YP	I/O	YP channel input	D
A2	XN	I/O	XN channel input	D
A3	YN	I/O	YN channel input	D
A4	AD0	I	Slave address input bit0	A
B1	XP	I/O	XP channel input	D
B2	PGND	-	Ground for touch screen drivers	-
B3	AD1	I	Test input(*1)	A
B4	SDA	I/O	Serial data(*2)	C
C1	PVDD	-	Power supply for touch screen drivers.	-
C2	AUX	I	Auxiliary channel input	D
C3	RSTB	I	System reset(*3)	A
C4	SCL	I	Serial clock(*2)	-
D1	VREF	-	Regulator output for control logic.(*4)	-
D2	GND	-	Ground	-
D3	VDD	-	Power supply	-
D4	INT	O	Interrupt output. Pin polarity with active low.	B

(*1) AD1 connect to GND.

(*2) SCL and SDA need pull-up with over 2.2kΩ resistor.

(*3) RSTB connect to VDD if not control.

(*4) VREF bypass to GND with a 1.0uF capacitor and cannot connect to supply.

●Equivalent circuit

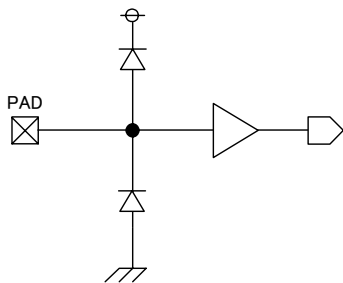

Fig.A

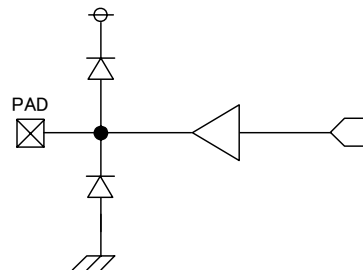

Fig.B

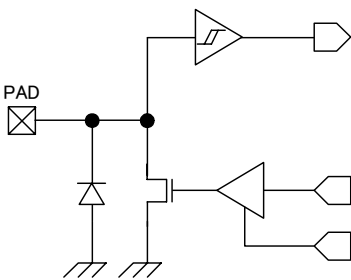

Fig.C

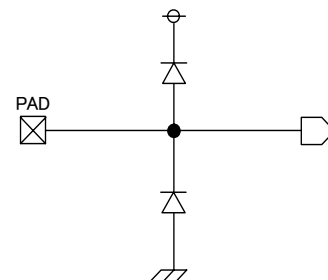
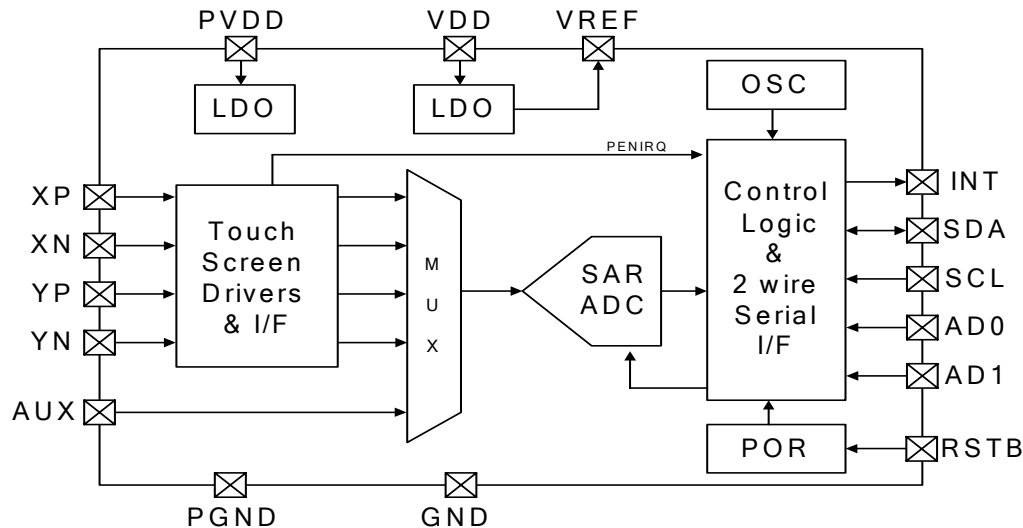

Fig.D

•Block diagram



•OVERVIEW

The BU21049GUL is a touch screen controller corresponding to a 4-wire resistive touch screen. 12-bit SAR A/D converter, clock oscillating circuit, power on reset circuit and LDO for inside blocks is built in one by one, and it operates with a 1.65V - 3.60V single power supply. The BU21049GUL can detect single point coordinates and touch pressure as existing 4-wire resistive touch screen controllers, and can generate data based on the prearranged touch screen parameters to detect dual coordinates.

Communication with the BU21049GUL is used 2-wire serial interface. The BU21049GUL operate as i2c slave device. The host processor can get control of the BU21049GUL by write to registers in the BU21049GUL and can select 2 operation mode which command control or automatic control. In automatic control, the BU21049GUL scan a touch screen and covert to touch data when touch screen is touched. The touch data is saved in the internal registers and read by the host processor at any time.

• Preprocess

The A/D converting is continuously done some times in one driving time. The data is median average processed. The median average processing is done that sorting the data and calculation that takes the average from the center of the sorting data. There is some effective for reduce noise influence.

• Interrupt control

The BU21049GUL will output an interrupt signal to the host processor with the INT pin, if a touch is detected. (In automatic control, after scan of the 1st touch data is completed). The INT pin polarity with active low.

• Power control

After a conversion function is completed, the BU21049GUL will be a power down automatically in order to reduce current consumption. In automatic control, it return from a power down and restart scan automatically by operating a touch screen during a power down.

• Power on reset

The BU21049GUL builds in the power-on-reset circuit. The RSTB pin can short VDD, if the host processor is not control the RSTB pin. If shorted, registers of the BU21049GUL initialization with power-on.

●ABSOLUTE MAXIMUM RATINGS

Parameter	Symbol	Rating	Unit	Conditions
Power supply voltage	VDD	-0.3~4.5	V	
Power supply voltage for touch screen	PVDD	-0.3~4.5	V	
Digital input voltage	VIN1	-0.3~VDD+0.3	V	AD0,AD1,SDA, SCL and RSTB
AUX input voltage	VIN2	GND-0.3~2.5	V	AUX
Voltage input to touch screen Interface	VIN3	GND-0.3~2.5	V	XP,YP,XN and YN
Package power dissipation	Pd	750	mW	(*1)
Storage temperature range	Tstg	-50~125	°C	

(*1) Ambient temperature reduces a permission loss by 7.50mW per case more than 25 degree Celsius, 1degree Celsius.

●RECOMMENDED OPERATING CONDITIONS

Parameter	Symbol	Rating			Unit	Conditions
		Min	Typ	Max		
Power supply voltage	VDD	1.65	3.00	3.60	V	
Power supply voltage for touch screen	PVDD	1.65	-	VDD	V	VDD ≥ PVDD
Operating temperature	Topr	-20	25	85	°C	

●ELECTRICAL CHARACTERISTICS (Ta=25°C, VDD=PVDD=3.00V, GND=0.00V, unless otherwise noted)

Parameter	Symbol	Rating			Unit	Conditions
		Min	Typ	Max		
Low-level input voltage	VIL	GND-0.3	-	VDD*0.2	V	AD0,AD1,SDA,SCL and RSTB
High-level input voltage	VIH	VDD*0.8	-	VDD+0.3	V	AD0,AD1,SDA,SCL and RSTB
Low-level output voltage1	VOL1	-	-	GND+0.4	V	SDA(IL=5mA),INT(IL=3mA), VDD ≥ 2.0V
Low-level output voltage2	VOL2	-	-	VDD*0.2	V	SDA(IL=5mA),INT(IL=3mA), VDD < 2.0V
High-level output voltage1	VOH1	VDD-0.4	-	-	V	INT,IL=-3mA VDD ≥ 2.0V
High-level output voltage2	VOH2	VDD*0.8	-	-	V	INT,IL=-3mA VDD < 2.0V
Standby current	Ist	-	-	1.0	uA	RSTB=L
Sleep current	Islp	-	100	200	uA	RSTB=H
Active current	Iact	-	0.8	2.0	mA	No Load
Resolution	Ad	12			Bit	
Differential non-linearity error	DNL	-3	-	+3	LSB	
Integrate non-linearity error	INL	-5	-	+5	LSB	

●Host interface AC timing

The slave address for 2-wire serial interface is selectable from “40h” or “41h” by “AD0” input.

AD0 = “L” : Slave Address = 40h
 AD0 = “H” : Slave Address = 41h

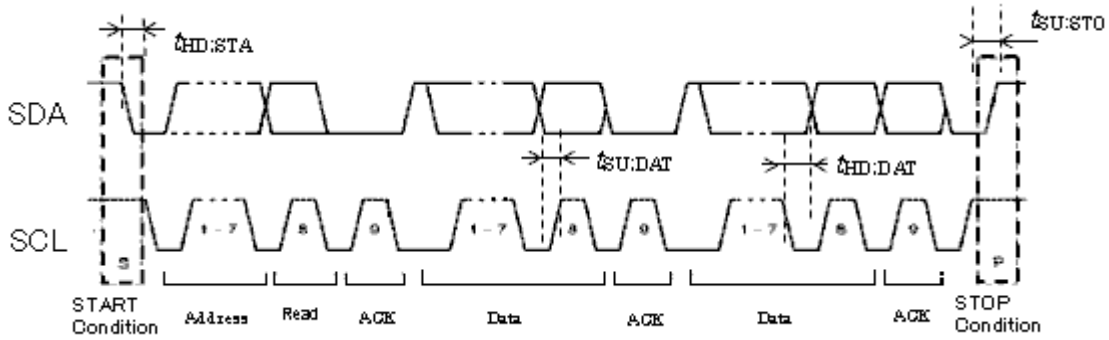

2-wire serial I/F AC timing characteristics (Ta=25°C, VDD=PVDD=3.00V, GND=0.00V, unless otherwise noted)

Parameter	Symbol	Rating			Unit	Condition
		MIN	TYP	MAX		
SCL clock frequency	f _{SCL}	0	-	400	kHz	
START condition hold time	t _{HD:STA}	0.6	-	-	us	
SCL “L” period	t _{LOW}	1.3	-	-	us	
SCL “H” period	t _{HIGH}	0.6	-	-	us	
Data hold time	t _{HD:DAT}	0.0	-	-	us	
Data setup time	t _{SU:DAT}	0.1	-	-	us	
STOP condition setup time	t _{SU:STO}	0.6	-	-	us	

●Host interface specification

The BU21049GUL operates as I2C slave device. The host processor transmit address byte after start condition when start communication with the BU21049GUL. In case of operate convert function or write to register of the BU21049GUL, the host processor transmit command byte after receive acknowledge of address byte. Communication with the BU21049GUL is end when receive stop condition.

Address byte

Slave address for 2-wire interface is placed in the upper 7-bit of address byte and the last bit is READ/WRITE. The upper 6-bit of slave address is fixed to "100000", and the last bit of slave address is selected by "AD0" input.

Serial interface slave address byte

MSB D7	D6	D5	D4	D3	D2	D1	LSB D0
1	0	0	0	0	0	A0	R/W

Bit D1: A0

Slave address bit0 (AD0)

Bit D0: R/W

1=read (reading data)

0=write (writing data)

Command byte

The BU21049GUL operates depend on command byte. The host processor set CID (D7) to 1 when perform convert function or set CID(D7) to 0 when perform register access..

Serial interface Command byte 1(CID=1)

MSB D7	D6	D5	D4	D3	D2	D1	LSB D0
1	CF				CMSK	PDM	STP

Bit D7: Command Byte ID

1= Command Byte 1(start conversion function according to CF(Bit D6-D3))

Bits D6-D4: CF

Convert function select as detailed the below.

BU21049GUL Convert function List

CF	Description
0x0	Touch screen scan function: X, Y, Z1 and Z2 coordinates and converted.
0x1	NOP
0x2	Auxiliary input converted.
0x3	Reserved
0x4	Free scan function: Drivers status and input of A/D assignment by Host.
0x5	Calibration: Paramters which used dual touch detection calibrated.
0x6	NOP
0x7	NOP
0x8	X+, X- drivers status.
0x9	Y+, Y- drivers status.
0xA	Y+, X- drivers status.
0xB	NOP
0xC	Touch screen scan function: X coordinate converted.
0xD	Touch screen scan function: Y coordinate converted.
0xE	Touch screen scan function: Z1 and Z2 coordinates converted.
0xF	Reserved

CF= 0000 : Automatic scan

The BU21049GUL periodically scan touch screen and convert without the host processor while detecting touch. When touch is not detected, BU21049GUL stop function and keep power down state until detect next pen-down. The order of scan process is Z1, Z2, X and Y.

CF= 0001, 0110, 0111, 1011

No operation. ("PDM" and "STP" is valid.)

CF= 0100 : Free scan mode

Selectable the driver (X+, X-, Y+, Y-) state and convert input(X+, X-, Y+, Y-, AUX) as optionally by register setting.

CF= 0101 : Calibration

Calibrate parameter for dual touch detection. To activate dual touch function, need to set CF=0101 and execute calibration command after power on.

CF= 1000, 1001, 1010: Drivers status control

Activate analog circuit and panel driver corresponding to each command. BU21049GUL keep this state until receive other SCAN instruction or be set "STP".

CF= 1100, 1101, 1110: Manual scan

Convert coordination which corresponding to each command. BU21049GUL change state to power down after complete conversion when "PDM" is set "0", and if "PDM" is set "1", keep power on.

CF= 0011, 1111

Reserved.

Bit D2 : CMSK

0=Execute convert function.

1=NOT execute convert function, only use for reading the convert result.

Bit D1 : PDM

Power down control

0= Power down after converter function stop.

1= NOT power down after converter function stop.

Bit D0 : STP

1=The BU21049GUL abort current running conversion and change state to power down. STP is automatically set "0".

Serial interface Command byte 0(CID=0)

MSB D7	D6	D5	D4	D3	D2	D1	LSB D0
0	ADDR[3:0]				PAGE	SWRST	STP

Bit D7: Command Byte ID

0= Command Byte 0(read/write data registers address specified by ADDR(Bit D6-D3)).

Bits D6-D3: ADDR

D2: PAGE

“ADDR” and “PAGE” can select access register address as the below.

BU21049GUL Register map

PAGE	ADDR	INI	7	6	5	4	3	2	1	0	
0	0x0	0x20	RSV0	RSV0	CALIB	INTRM	RSV0	RSV0	RSV0	RSV0	
	0x1	0xA6	MAV	AVE			-	SMPL			
	0x2	0x04	INTVL_TIME				TIME_ST_ADC				
	0x3	0x10	EVR_X								
	0x4	0x10	EVR_Y								
	0x5	0x10	EVR_XY								
	0x6	0x00	RSV0								
	0x7	0x00	RSV0								
	0x8	0x00	-	-	-	-	RSV0				
	0x9	0x0F	-	-	-	PIMIR_X					
	0xA	0x0F	-	-	-	PIMIR_Y					
	0xB	0x72	RM8	STRETCH	PU90K	DUAL	PIDAC_OFS				
	0xC	0x00	-	PVDD			-	AVDD			
	0xD	0x00	TEST	AUTO	PDM	-	BUSY	ACTIVE	CALIB DONE	TOUCH	
	0xE	0x02	HW_IDH								
	0xF	0x49	HW_IDL								
1	0x0	0x00	SW_YP_ POW	SW_YP_ GND	SW_YN_ POW	SW_YN_ GND	SW_XP_ POW	SW_XP_ GND	SW_XN_ POW	SW_XN_ GND	
	0x1	0x00	RSV	VREFN_XN	VREFN_YN	SW_AUX	SW_YPM	SW_YNM	SW_XPM	SW_XNM	
	0x2-0xF	-	Reserved								

(*1)RSV0 must be set 0.

(*2)INI= Initial value

Bit D1: SWRST

1= The BU21049GUL initialize all register, stop all operation and change state to power down. SWRST is automatically set “0”.

Bit D0: STP

1= The BU21049GUL abort current running conversion and change state to power down. STP is automatically set “0”.

WRITE CYCLE

The 7-bit slave address is placed in the upper of address byte and Read/Write bit is in the LSB. The BU21049GUL issue an acknowledgement after address byte if access is correct. After received the acknowledgement, HOST can send command byte. When HOST received an acknowledgement of command byte from BU21049GUL, HOST continuously sends a write data byte or issues a STOP condition.

Write : Convert function

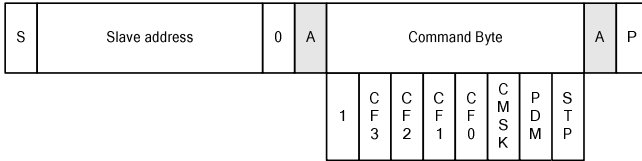

Write : Register write

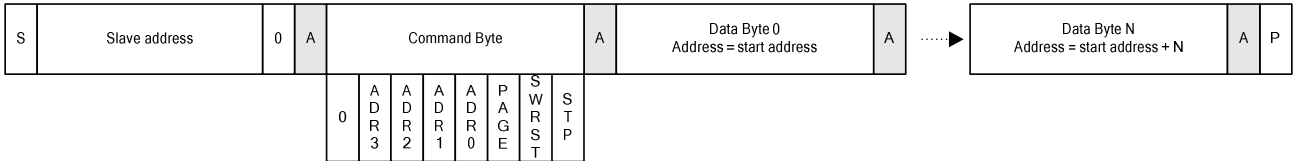

S: START condition P: STOP condition A: ACK N: NACK

READ CYCLE

The LSB of address byte is READ bit. The BU21049GUL send back data byte followed by an acknowledge at read mode. The send back data is conversion result or register value. (It's depend on last command byte) HOST needs to resend conversion command with setting "CMSK=1" if HOST read register value before read conversion result. BU21049GUL send back next data byte if BU21049GUL receive the acknowledge from HOST after sending data byte. HOST finish read access by issuing a START condition (or STOP condition) followed by a not-acknowledge(NACK) when HOST received last data byte.

Read cycle

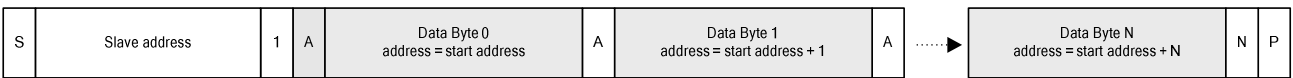

S: START condition P: STOP condition A: ACK N: NACK

SCL STRETCH

If HOST read conversion result while BU21049GUL is operating conversion, the BU21049GUL notify HOST by SCL_STRETCH function.(*1) The SCL_STRECH is released when conversion function was finished.

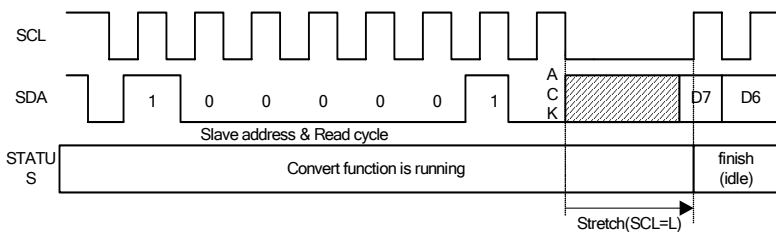

(*1)Force SCL to "L" after ACK of slave address.

●Power supply and reset timing specification

The BU21049GUL will be in standby state, if the RSTB pin is low, and the host processor cannot communicate with the BU21049GUL. If pass the time(defined by Tdelay) after the RSTB pin is set to high, the BU21049GUL will be in idle state and comes to be able to perform communication with the host processor.
 The RSTB pin is connectable with power supply by the power-on-reset circuit.

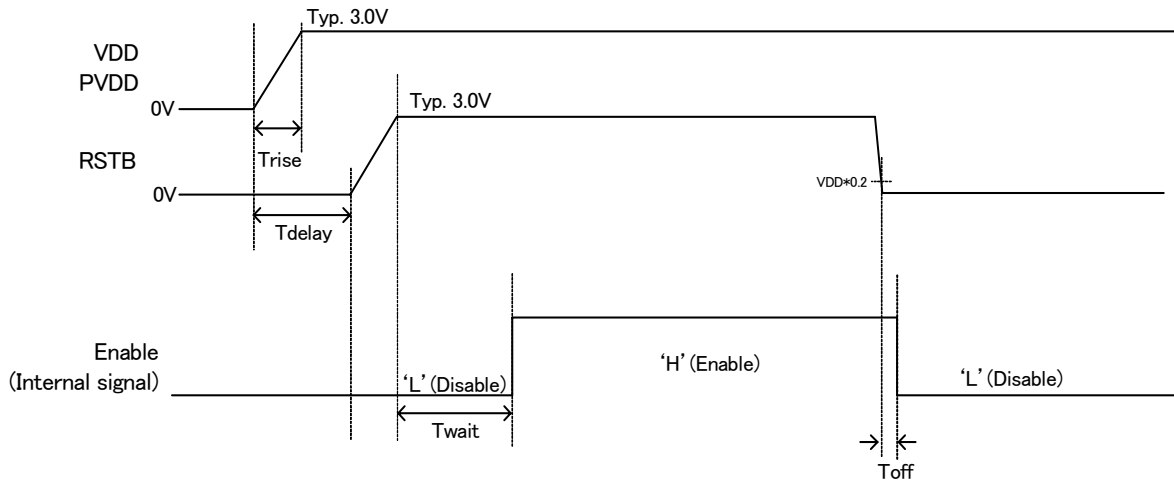

Power-on-reset AC timing characteristics (Ta=25°C, VDD=PVDD=3.00V, GND=0.00V, unless otherwise noted)

Parameter	Symbol	Rating			Unit	Condition
		MIN	TYP	MAX		
VDD rise time	Trise	0.01	-	10	ms	
RSTB delay time	Tdelay	0	-	-	ms	
Enable delay time	Twait	-	-	1	ms	VREF Cload=1.0uF
RSTB time	Toff	1	-	30	us	VREF Cload=1.0uF

•Specification of touch detection

The BU21049GUL builds in the touch detection function for outputting the interrupt signal to the INT pin during detect touch. The equivalent circuit schematic of a touch detection function is shown in the following figure.

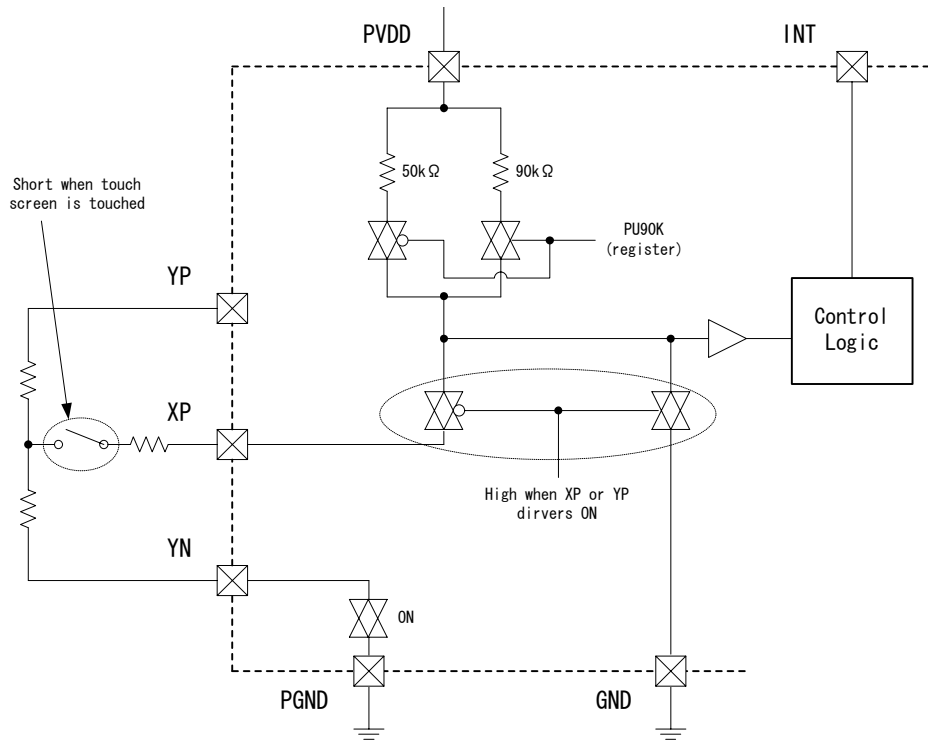

When the touch panel is connected to the panel interface terminal (XP, XN, YP, YN), XP pin is connected to PVDD through internal pull-up resistance inside IC, the YN pin connects with PGND, and the BU21049GUL will be in a standby state at the no-touch. At this time, the INT pin outputs "H" by an internal pull-up.

Since the XP pin and the YN pin are connected through the contact resistance of a touch screen when a touch screen is touched, the resistance ratio of internal pull-up resistance and touch screen resistance detects the voltage drop of the XP pin, and it outputs "L" from the INT pin.

Moreover, when a touch is detected and the XP pin or the YP pin changes into a drive state by each scanning operation, internal pull-up resistance is separated from the XP pin, and the "L" output of the INT pin is held.

●Control flow chart

The BU21049GUL has two operational modes, the command mode which operates by control of a host processor, and the auto mode which operates by automatic control.

To use a two-point detection function, it is necessary to compensate the circuit for two-point detection of the BU21049GUL firstly in the state which set the panel parameter (register Addr.0x3, 0x4). Compensation of the circuit for two-point detection is performed by transmitting an exclusive command (CF=0101) from the host processor. The host processor should initialize each register after power-on. At the time of two-point detection, please enable the interrupt signal from IC after performing parameter correction.

Table. The BU21049UL Power-on sequence

step	state	operation
1	Power-on	Supply power and release reset. Set disable (mask) interruption of the BU21049GUL.
2	initialization 1 (For 2 points detection only)	After waiting time of reset release, initialize each register of the BU21049GUL via I2C bus from the host processor.
3	initialization 2 (For 2 points detection only)	The host processor check not being touched in the touch screen from the INT pin or status register in the BU21049GUL. The host processor repeat this step as long as a touch is detected.
4		The host processor transmit the calibration command(CF=0101) via I2C bus.
5		The BU21049GUL operates calibration of 2 point touch detection parameters and set CALIB_DONE of status register to 1.
6		It stands by until BIT of a definite period or CALIB_DONE is turned on.
7		initialization 3 (For Auto mode only)
8	Normal (finish)	The host processor enable an interrupt from the BU21049GUL and operates the other process or keep idle state until an interrupt detected.

Calibration flow

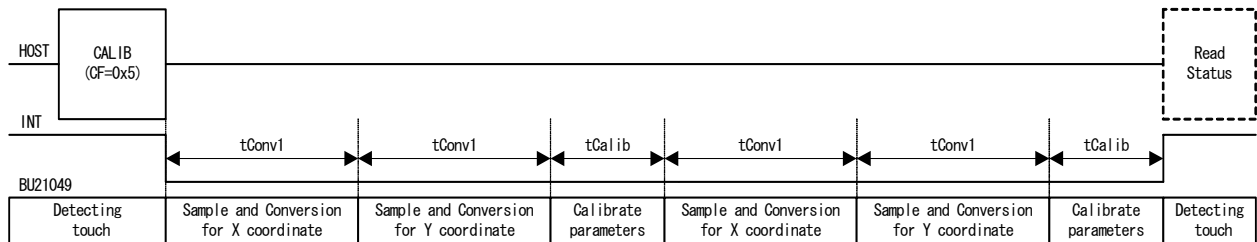

(*1) Even if a dashed line part does not perform, it does not have influence on operation.

- tPON = 710us
- tDLY1 = 1.5us
- tADC = 18us
- tDLY2 = 1.0us
- tTIME_ST_ADC = register (addr.0x2)
- tSMPL = register (addr.0x1)

$$tConv1 = tPON + tDLY1 + (tTIME_ST_ADC + (tADC * tSMPL) + tDLY2)$$

$$tCalib = 1 \text{ internal clock}$$

Command mode

The BU21049GUL operates according to the control (command) by the host processor completely. In order to take touch data, as long as touch pressure is ON, the host processor needs to continue controlling the BU21049GUL. Moreover, since it is necessary to certainly transmit a command for taking touch data, processing of a host interface becomes active compared with an auto system between ON of touch pressure.

Table. Command method sequence

step	touch screen	operation
1	not touched	The BU21049GUL is in idle state(power down). The host processor operates the other process or keep the idle state.
2	touched	The BU21049GUL detect a touch and transmit interrupt to the host processor.
3		The host processor disable interrupt from the BU21049GUL.
4		The host processor transmit command of X data conversion via I2C bus.
5		The BU21049GUL turns on X drivers and makes the X-axis of the touch screen turn on electricity.
6		The BU21049GUL converts the X data from the touch screen ad transmits via I2C bus.
7		The host processor receives center data and 2 points data(total 4 byte). When not detecting 2 points, only center data(2 byte) is received. When the host processor need 2 or more data by filter processing etc., it repeats step 4~7.
8		The host processor transmit command of Y data conversion via I2C bus.
9		After the BU21049GUL turns off X drivers, it turns on Y drivers and makes the Y-axis of the touch screen turn on electricity.
10		The BU21049GUL converts the Y data from the touch screen ad transmits via I2C bus.
11		The host processor receives center data and 2 points data and ghost data(total 6 byte). When not detecting 2 points, only center data(2 byte) is received. When the host processor need 2 or more data by filter processing etc., it repeats step 8~11.
12		The host processor transmit command of Z data conversion via I2C bus.
13		After the BU21049GUL turns off Y drivers, it turns on Z drivers(*1) and makes the Z-axis of the touch screen turn on electricity.
14		The BU21049GUL converts the Z data from the touch screen ad transmits via I2C bus.
15	The host processor receives Z data(total 4 byte). When the host processor need 2 or more data by filter processing etc., it repeats step 12~15.	
16	The host processor calculates all the data and covert into touch coordinates.	
17	The host processor checks the touch pressure from the INT pin or status register in the BU21049GUL. Step 4~16 repeated when there is touch pressure.	
18	not touched	turn back to step 1.

(*1) Z driver: YP=VDD, XN=GND state

(*2) Refer to the dual coordinates conversion (p. 17) for the conversion on coordinates from read data.

Touch screen scan flow 1 (X and Y scan)

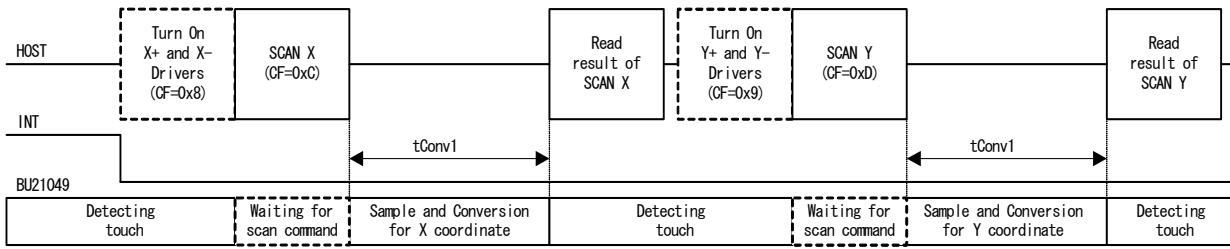

Touch screen scan flow 2 (Z1 and Z2 scan)

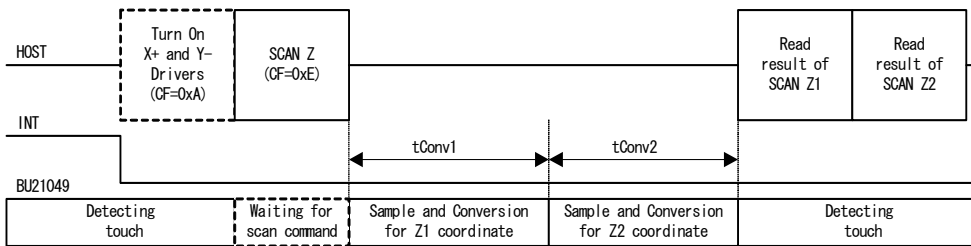

tPON = 710us

tDLY1 = 1.5us

tADC = 18us

tDLY2 = 1.0us

tTIME_ST_ADC = register (addr.0x2)

tSMPL = register (addr.0x1)

tConv1 = tPON + tDLY1 + (tTIME_ST_ADC + (tADC * tSMPL) + tDLY2)

tConv2 = tDLY1 + (tADC * tSMPL) + tDLY2

(*1) Time is calculated with the oscillating frequency of the internal OSC is 8MHz.

(*2) In the case of PDM=1, tPON(s) is set to zero except for the first time.

(*3) A dashed line part is required only when set apply time to a panel more than tTIME_ST_ADC.

Auto mode

The BU21049GUL takes all of the detected touch pressure and the touch data by automatic control. An interrupt signal is transmitted to the timing which the 1st data taken after detecting touch pressure completed.

In order for the BU21049GUL to continue taking touch data without control of the host processor, the host processor does not need to control a touch screen.

Auto mode operation is started to the timing which received SCAN-XYZ (CF=0000) from the host processor. The INT pin is not concerned with a touch state, but is set to "H" until the 1st touch data is acquired after a start of operation.

Table. Auto method sequence

step	touch screen	operation
1	not touched	The BU21049GUL is in idle state(power down). The host processor operates the other process or keep the idle state.
2	touched	The BU21049GUL detect a touch and turn on Z drivers(*1).
3		The BU21049GUL converts the Z data from the touch screen and saves a result to temporary.
4		After the BU21049GUL turn off Z drivers, it turns on X drivers and makes the X-axis of the touch screen turn on electricity.
5		The BU21049GUL converts the X data from the touch screen and saves a result to temporary.
6		After the BU21049GUL turn off X drivers, it turns on Y drivers and makes the Y-axis of the touch screen turn on electricity.
7		The BU21049GUL converts the Y data from the touch screen and saves a result to temporary.
8		The BU21049GUL checks touch pressure. When touch pressure is detected, all conversion result copied to internal registers in the BU21049GUL, transmit interrupt signal to the host processor and it turn back to step 2. When touch pressure is undetected, all conversion result are cancelled, transmission of an interrupt signal is stopped, and it turn back to step 1.
9		The host processor does the mask of the interruption after receiving an interrupt signal.
10		The host processor received all touch data and 2 points data(total 14 byte) via I2C bus and convert to touch coordinates.(*2) When not detecting 2 points, only touch data(8 byte) is received.
11		The host processor checks the touch pressure from the INT pin or status register in the BU21049GUL. Trun back to step 10 when there is touch pressure.

(*1) Z driver: YP=VDD, XN=GND state

(*2) Refer to the dual coordinates conversion (p. 17) for the conversion on coordinates from read data.

Touch screen scan flow 3(XYZ scan)

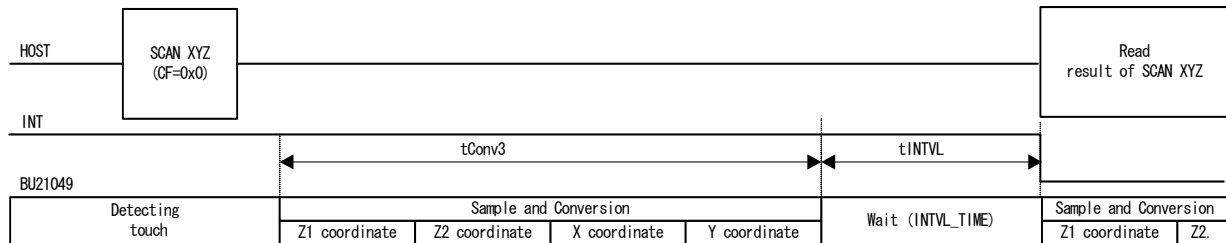

tPON = 710us

tDLY1 = 1.5us

tADC = 18us

tDLY2 = 1.0us

tTIME_ST_ADC = register (addr.0x2)

tINTVL = register (addr.0x2)

tSMPL = register (addr.0x1)

$$tConv3 = tPON + tDLY1 + (tTIME_ST_ADC + (tADC * tSMPL) + tDLY2) * 3$$

(*1) Time is calculated with the oscillating frequency of the internal OSC is 8MHz.

(*2) In the case of PDM=1, tPON(s) is set to zero except for the first time.

(*3) An order of taking each touch data, etc. cannot be changed.

●dual coordinates conversion

The touch position of dual touch is convertible for coordinates because the host processor processes the data which the BU21049GUL outputs. The data outputted changes with the commands received from the host processor as shown in Table1. The host processor should take data from the BU21049GUL by the burst read via I2C. When reception is stopped and it resumes before taking all the data, it is again outputted from Byte0.

When using it only by single point detection, it may be end reception to the timing which take each coordinates.

Table1. The output data list of each command

Byte	Command method X data taking	Command method Y data taking	Command method Z data taking	Auto method
0	X coordinate	Y coordinate	Z1 coordinate	X coordinate
1				
2	X 2 points paramter	Y 2 points paramter	Z2 coordinate	Y coordinate
3				
4	Dummy	Ghost parameter	Dummy	Z1 coordinate
5				
6	-	-	-	Z2 coordinate
7	-	-	-	
8	-	-	-	X 2 points paramter
9	-	-	-	
10	-	-	-	Y 2 points paramter
11	-	-	-	
12	-	-	-	Ghost parameter
13	-	-	-	
14	-	-	-	Dummy
15	-	-	-	

Table2. The output data format list

DATA	ByteH								ByteL							
	Bit07	Bit06	Bit05	Bit04	Bit03	Bit02	Bit01	Bit00	Bit07	Bit06	Bit05	Bit04	Bit03	Bit02	Bit01	Bit00
X coordinate	X[11]	X[10]	X[9]	X[8]	X[7]	X[6]	X[5]	X[4]	X[3]	X[2]	X[1]	X[0]	0	0	0	0
Y coordinate	Y[11]	Y[10]	Y[9]	Y[8]	Y[7]	Y[6]	Y[5]	Y[4]	Y[3]	Y[2]	Y[1]	Y[0]	0	0	0	0
Z1 coordinate	Z1[11]	Z1[10]	Z1[9]	Z1[8]	Z1[7]	Z1[6]	Z1[5]	Z1[4]	Z1[3]	Z1[2]	Z1[1]	Z1[0]	0	0	0	0
Z2 coordinate	Z2[11]	Z2[10]	Z2[9]	Z2[8]	Z2[7]	Z2[6]	Z2[5]	Z2[4]	Z2[3]	Z2[2]	Z2[1]	Z2[0]	0	0	0	0
X 2 points parameter	PX[9]	PX[8]	PX[7]	PX[6]	PX[5]	PX[4]	PX[3]	PX[2]	PX[1]	PX[0]	0	0	0	0	0	SPX
Y 2 points parameter	PY[9]	PY[8]	PY[7]	PY[6]	PY[5]	PY[4]	PY[3]	PY[2]	PY[1]	PY[0]	0	0	0	0	0	SPY
Ghost parameter	GH[11]	GH[10]	GH[9]	GH[8]	GH[7]	GH[6]	GH[5]	GH[4]	GH[3]	GH[2]	GH[1]	GH[0]	0	0	0	SGH

(*1)The ByteH is the even number Byte. The ByteL is the odd number Byte. It means that X coordinates are ByteH=Byte0 and ByteL=Byte1 when it is taken with a command method.

X coordinate: Touched coordinate of X. It becomes gravity center coordinate of 2 points at dual touch.

$$X = \text{ByteH} * 16 + \text{ByteL} / 16$$

Y coordinate: Touched coordinate of Y. It becomes gravity center coordinate of 2 points at dual touch.

$$Y = \text{ByteH} * 16 + \text{ByteL} / 16$$

Z1 coordinate: Touched coordinate of Z1. It's used when calculate touch pressure.

$$Z1 = \text{ByteH} * 16 + \text{ByteL} / 16$$

Z2 coordinate: Touched coordinate of Z2. It's used when calculate touch pressure.

$$Z2 = \text{ByteH} * 16 + \text{ByteL} / 16$$

The X dual parameter: It is the pointer of table which used when calculate 2 points distance of X-axis.

$$\text{PX} = \text{ByteH} * 4 + \text{ByteL} / 64 \text{ (In the case of SPX=0)}$$

$$\text{PX} = 0x400 - (\text{ByteH} * 4 + \text{ByteL} / 64) \text{ (In the case of SPX=1)}$$

The Y dual parameter: It is the pointer of table which used when calculate 2 points distance of Y-axis.

$$\text{PY} = \text{ByteH} * 4 + \text{ByteL} / 64 \text{ (In the case of SPY=0)}$$

$$\text{PY} = 0x400 - (\text{ByteH} * 4 + \text{ByteL} / 64) \text{ (In the case of SPY=1)}$$

Ghost parameter: It is a value for judging a touch position (the direction of inclination) at dual touch.

$$\text{GH} = \text{ByteH} * 16 + \text{ByteL} / 16 \text{ (In the case of SPY=0)}$$

$$\text{GH} = 0x1000 - (\text{ByteH} * 16 + \text{ByteL} / 16) \text{ (In the case of SPY=1)}$$

Table3. Dual coordinates conversion flow

step	operation
1	All the data is acquired and converted according to procedure (p.16).
2	If required, a filter etc. will be processed to data.
3	If only 1-point touch detection, conversion is end.
4	2 points touch detection: 2 points touch is detected comparing PX, PY and GH with threshold. If 2-point touch is not detected, conversion is end.
5	X-axis 2-point distance calculation 1: Data is acquired from the distance conversion table using the maximum of 2 points distance determined beforehand. The data is set to PRMX1.
6	X-axis 2-point distance calculation 2: Data is acquired from the distance conversion table using PX. The data is set to PRMX2.
7	X-axis 2-point distance calculation 3: The 2 points distance of X-axis (DX) calculated. $DX = 2048 * (PRMX2 / PRMX1)$
8	Y-axis 2-point distance calculation 1: Data is acquired from the distance conversion table using the maximum of 2 points distance determined beforehand. The data is set to PRMY1.
9	Y-axis 2-point distance calculation 2: Data is acquired from the distance conversion table using PY. The data is set to PRMY2.
10	Y-axis 2-point distance calculation 3: The 2 points distance of Y-axis (DY) calculated. $DY = 2048 * (PRMY2 / PRMY1)$
11	X-axis 2-point touch coordinate conversion: X-axis 2-point touch coordinate convert from center position(X) and distance(DX). $X1 = X + DX$ $X2 = X - DX$
12	Y-axis 2-point touch coordinate conversion: Y-axis 2-point touch coordinate convert from center position(Y), distance(DY) and ghost value(GH). When GH more than threshold. $Y1 = Y + DY$ $Y2 = Y - DY$ When GH less than threshold. $Y1 = Y - DY$ $Y2 = Y + DY$
13	It is generated, and since they are not exact coordinates, if 2-point coordinates are required, they process offset etc.
14	conversion is end.

●Register description

PAGE=0, ADDR=0x0

D7	D6	D5	D4	D3	D2	D1	D0
RSV0	RSV0	CALIB	INTRM	RSV0	RSV0	RSV0	RSV0

Bits D7-D6, D3-D0: RSV0
Reserved. Set 0 these bits.

Bit D5 : CALIB

Internal parameter setting-1 for calibration of dual touch detection

0= NOT use calibration result

1= Use calibration result

Bit D4 : INTRM

Setting of INT states in case that BU21049GUL is active after convert operation by "PDM" setting.

0= depend on "pen-down"

1= always output "0"

PAGE=0, ADDR=0x1 : CFR1

D7	D6	D5	D4	D3	D2	D1	D0
MAV	AVE		-		SMPL		

Bit D7: MAV

Median Average Filter

0= Off

1= On

Bits D6-D4: AVE

AVE+1= The number of average samples setting for MAV. If AVE more than SMPL, it is even out SMPL.

Bits D2-D0: SMPL

SMPL+1= The number of conversion samples setting for MAV.

Ex. In the case of CFR1 = 0xA6 (the number of average samples is 3 and the number of conversion samples is 7)

Conversion result { 1676, 1688, 1656, 1677, 1659, 1702, 4095 }

Sorted result { 1656, 1659, 1676, 1677, 1688, 1702, 4095 }

Chose 3 center data { ~~1656, 1659~~, 1676, 1677, 1688, ~~1702, 4095~~ }

Average above 3 data = (1676 + 1677 + 1688) / 3 =1680 (vs averaged all six data = 2022)

PAGE=0, ADDR=0x2 : CFR2

D7	D6	D5	D4	D3	D2	D1	D0
INTVL_TIME[3:0]				TIME_ST_ADC[3:0]			

Bits D7-D4: INTVL_TIME

This is waiting time setting between conversion be completed and start next conversion.

(Only usable setting at conversion function=0x0.)

In the using case, set value as four or more.

INTVL_TIME setting table

value	time
0x0~0x3	Reserved
0x4	0.256ms
0x5	1.024ms
0x6	2.048ms
0x7	4.096ms
0x8	5.120ms
0x9	8.912ms
0xA	10.240ms
0xB	15.360ms
0xC~0xF	20.480ms

※Above showed time are calculated with the oscillating frequency of the internal OSC is 8MHz.

Bit D3-D0 : TIME_ST_ADC

This is waiting time setting between apply voltage to panel and starting A/D conversion.

TIME_ST_ADC setting table

value	time
0x0	8us
0x1	20us
0x2	30us
0x3	40us
0x4	50us
0x5	60us
0x6	70us
0x7	80us
0x8	90us
0x9	100us
0xA	200us
0xB	250us
0xC	300us
0xD	360us
0xE	400us
0xF	500us

※Above showed time are calculated with the oscillating frequency of the internal OSC is 8MHz.

PAGE=0, ADDR=0x3 ~ 0x5: EVR

D7	D6	D5	D4	D3	D2	D1	D0
EVR_*[7:0]							

Bits D7-D0: EVR_*

Gain setting 1 for dual touch detection. When using 2 points detection function, it is necessary to set here before conversion. It corresponds X, Y and XY (Z). EVR_XY is not necessary to change from initial value.

PAGE=0, ADDR=0x9, 0xA: PIMIR

D7	D6	D5	D4	D3	D2	D1	D0
-	-	-	PIMIR_*[4:0]				

Bits D7-D0: PIMIR_*

Gain setting 2 for dual touch detection. It is not necessary to change from initial value. It corresponds X and Y.

PAGE=0, ADDR=0xB: CFR3

D7	D6	D5	D4	D3	D2	D1	D0
RM8	STRETCH	PU90K	DUAL	PIDAC_OFS[3:0]			

Bit D7: RM8

Coordinate resolution setting

0= 12bit

1= 8bit

Bit D6: STRETCH

SCL_STRETCH function setting

0= off

1= on

Bit D5 : PU90K

Internal pull-up resistance for touch detection setting

0= about 90kΩ

1= about 50kΩ

Bit D4: DUAL

Dual touch detection function setting

0= Off

1= On

Bits D3-D0: PIDAC_OFS

Dual touch detection circuit adjustment setting. It is not necessary to change from initial value.

PAGE=0, ADDR=0xC: LDO

D7	D6	D5	D4	D3	D2	D1	D0
-	PVDD[2:0]			-	AVDD[2:0]		

Bits D6-D4: PVDD

Regulator for apply to panel output setting.

By increasing voltage, the effect which reduces the influence of the exogenous noise from a panel interface terminal is acquired.

PVDD setting table

value	output
0	1.500V
1	1.556V
2	1.615V
3	1.680V
4	1.750V
5	1.826V
6	1.909V
7	2.000V

Bits D2-D0: AVDD

The output voltage setting of the analog circuit regulator.

The relationship of setting value and output voltage is same as PVDD.

It is not possible to change from initial value when use with VDD or PVDD lower supply than 2.5V.

PAGE=0, ADDR=0xD: STATUS (Read only)

D7	D6	D5	D4	D3	D2	D1	D0
TEST	AUTO	PDM	-	BUSY	ACTIVE	CALIB _DONE	TOUCH

Bit D7: TEST

This bit will become "1" during TEST mode.

Bit D6: AUTO

This bit will become "1" at conversion function 0.

Bit D5: PDM

PDM setting value of command byte1.

Bit D3: BUSY

This bit will become "1" during IC converting coordinate data.

Bit D2: ACTIVE

This bit will become "1" when internal analog circuit is active.

Bit D1: CALIB

This bit will become "1" in case that dual touch detection parameter adjustment is finished by command (CF=0x5).

This bit will be clear when write "1" to this bit.

Bit D0: TOUCH

This bit will become "1" when detect pen-down at internally.

PAGE=0, ADDR=0xE: HW_ID1 (Read only)

D7	D6	D5	D4	D3	D2	D1	D0
HW_IDH							

Bits D7-D0: HW_IDH

High 8bit of IC's ID

PAGE=0, ADDR=0xF: ID (Read only)

D7	D6	D5	D4	D3	D2	D1	D0
HW_IDL							

Bits D7-D0: HW_IDL

Low 8-bit of IC's ID

PAGE=1, ADDR=0x0: FREE_SW1

D7	D6	D5	D4	D3	D2	D1	D0
SW_YP_ POW	SW_YP_ GND	SW_YN_ POW	SW_YN_ GND	SW_XP_ POW	SW_XP_ GND	SW_XN_ POW	SW_XN_ GND

Bits D7-D0: SW_**_POW(GND)

Driver setting at conversion function 4(Free scan)

Drive to "+" by set POW and "-" by set GND, Must not set "+" and "-" to one terminal at the same time.

** = the corresponding terminal name

PAGE=1, ADDR=0x1: FREE_SW2

D7	D6	D5	D4	D3	D2	D1	D0
RSV	VREFN_XN	VREFN_YN	SW_AUX	SW_YPM	SW_YNM	SW_XPM	SW_XNM

Bits D7 - D5: RSV0

Reserved. They must be set "0".

Bit D4: SW_AUX

Bit D3-D0: SW_**M

A/D input setting at conversion function 4(Free scan)

** = the corresponding terminal name

●Operational Notes

(1) Absolute Maximum Ratings

An excess in the absolute maximum ratings, such as supply voltage, temperature range of operating conditions, etc., can break down devices, thus making impossible to identify breaking mode such as a short circuit or an open circuit. If any special mode exceeding the absolute maximum ratings is assumed, consideration should be given to take physical safety measures including the use of fuses, etc.

(2) Operating conditions

These conditions represent a range within which characteristics can be provided approximately as expected. The electrical characteristics are guaranteed under the conditions of each parameter.

(3) Reverse connection of power supply connector

The reverse connection of power supply connector can break down ICs. Take protective measures against the breakdown due to the reverse connection, such as mounting an external diode between the power supply and the IC's power supply terminal.

(4) Power supply line

Design PCB pattern to provide low impedance for the wiring between the power supply and the GND lines. In this regard, for the digital block power supply and the analog block power supply, even though these power supplies has the same level of potential, separate the power supply pattern for the digital block from that for the analog block, thus suppressing the diffraction of digital noises to the analog block power supply resulting from impedance common to the wiring patterns. For the GND line, give consideration to design the patterns in a similar manner. Furthermore, for all power supply terminals to ICs, mount a capacitor between the power supply and the GND terminal. At the same time, in order to use an electrolytic capacitor, thoroughly check to be sure the characteristics of the capacitor to be used present no problem including the occurrence of capacity dropout at a low temperature, thus determining the constant.

(5) GND voltage

Make setting of the potential of the GND terminal so that it will be maintained at the minimum in any operating state. Furthermore, check to be sure no terminals are at a potential lower than the GND voltage including an actual electric transient.

(6) Short circuit between terminals and erroneous mounting

In order to mount ICs on a set PCB, pay thorough attention to the direction and offset of the ICs. Erroneous mounting can break down the ICs. Furthermore, if a short circuit occurs due to foreign matters entering between terminals or between the terminal and the power supply or the GND terminal, the ICs can break down.

(7) Operation in strong electromagnetic field

Be noted that using ICs in the strong electromagnetic field can malfunction them.

(8) Inspection with set PCB

On the inspection with the set PCB, if a capacitor is connected to a low-impedance IC terminal, the IC can suffer stress. Therefore, be sure to discharge from the set PCB by each process. Furthermore, in order to mount or dismount the set PCB to/from the jig for the inspection process, be sure to turn OFF the power supply and then mount the set PCB to the jig. After the completion of the inspection, be sure to turn OFF the power supply and then dismount it from the jig. In addition, for protection against static electricity, establish a ground for the assembly process and pay thorough attention to the transportation and the storage of the set PCB.

(9) Input terminals

In terms of the construction of IC, parasitic elements are inevitably formed in relation to potential. The operation of the parasitic element can cause interference with circuit operation, thus resulting in a malfunction and then breakdown of the input terminal. Therefore, pay thorough attention not to handle the input terminals, such as to apply to the input terminals a voltage lower than the GND respectively, so that any parasitic element will operate. Furthermore, do not apply a voltage to the input terminals when no power supply voltage is applied to the IC. In addition, even if the power supply voltage is applied, apply to the input terminals a voltage lower than the power supply voltage or within the guaranteed value of electrical characteristics.

(10) Ground wiring pattern

If small-signal GND and large-current GND are provided, It will be recommended to separate the large-current GND pattern from the small-signal GND pattern and establish a single ground at the reference point of the set PCB so that resistance to the wiring pattern and voltage fluctuations due to a large current will cause no fluctuations in voltages of the small-signal GND. Pay attention not to cause fluctuations in the GND wiring pattern of external parts as well.

(11) External capacitor

In order to use a ceramic capacitor as the external capacitor, determine the constant with consideration given to a degradation in the nominal capacitance due to DC bias and changes in the capacitance due to temperature, etc.

(12) Rush current

The IC with some power supplies has a capable of rush current due to procedure and delay at power-on. Pay attention to the capacitance of the coupling condensers and the wiring pattern width and routing of the power supply and the GND lines.

(13) Others

In case of use this LSI, please peruse some other detail documents, we called, Technical note, Functional description, Application note.

Status of this document

The Japanese version of this document is formal specification. A customer may use this translation version only for a reference to help reading the formal version.

If there are any differences in translation version of this document formal version takes priority

•Ordering Information

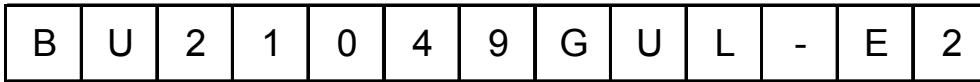

Package
GUL: VCSP50L2

Tape and Reel information
E2: Embossed carrier tape

•Physical Dimension Tape and Reel Information

VCSP50L2(BU21049GUL)

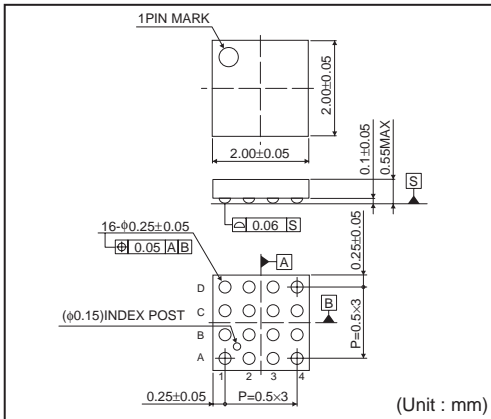

<Tape and Reel information>

Tape	Embossed carrier tape
Quantity	3000pcs
Direction of feed	E2 (The direction is the 1pin of product is at the upper left when you hold reel on the left hand and you pull out the tape on the right hand)

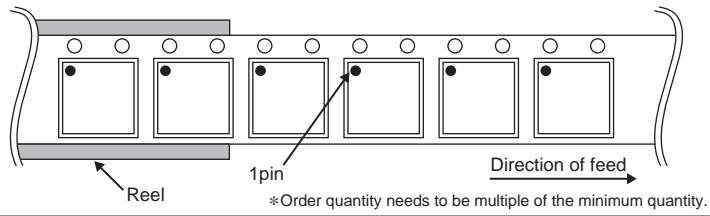

•Marking Diagram

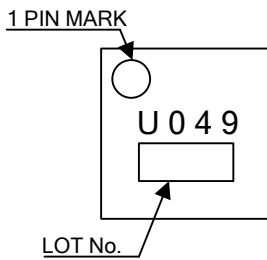

Notice

●General Precaution

- 1) Before you use our Products, you are requested to carefully read this document and fully understand its contents. ROHM shall not be in any way responsible or liable for failure, malfunction or accident arising from the use of any ROHM's Products against warning, caution or note contained in this document.
- 2) All information contained in this document is current as of the issuing date and subject to change without any prior notice. Before purchasing or using ROHM's Products, please confirm the latest information with a ROHM sales representative.

●Precaution on using ROHM Products

- 1) Our Products are designed and manufactured for application in ordinary electronic equipments (such as AV equipment, OA equipment, telecommunication equipment, home electronic appliances, amusement equipment, etc.). If you intend to use our Products in devices requiring extremely high reliability (such as medical equipment, transport equipment, traffic equipment, aircraft/spacecraft, nuclear power controllers, fuel controllers, car equipment including car accessories, safety devices, etc.) and whose malfunction or failure may cause loss of human life, bodily injury or serious damage to property ("Specific Applications"), please consult with the ROHM sales representative in advance. Unless otherwise agreed in writing by ROHM in advance, ROHM shall not be in any way responsible or liable for any damages, expenses or losses incurred by you or third parties arising from the use of any ROHM's Products for Specific Applications.
- 2) ROHM designs and manufactures its Products subject to strict quality control system. However, semiconductor products can fail or malfunction at a certain rate. Please be sure to implement, at your own responsibilities, adequate safety measures including but not limited to fail-safe design against the physical injury, damage to any property, which a failure or malfunction of our Products may cause. The following are examples of safety measures:
 - [a] Installation of protection circuits or other protective devices to improve system safety
 - [b] Installation of redundant circuits to reduce the impact of single or multiple circuit failure
- 3) Our Products are designed and manufactured for use under standard conditions and not under any special or extraordinary environments or conditions, as exemplified below. Accordingly, ROHM shall not be in any way responsible or liable for any damages, expenses or losses arising from the use of any ROHM's Products under any special or extraordinary environments or conditions. If you intend to use our Products under any special or extraordinary environments or conditions (as exemplified below), your independent verification and confirmation of product performance, reliability, etc. prior to use, must be necessary:
 - [a] Use of our Products in any types of liquid, including water, oils, chemicals, and organic solvents
 - [b] Use of our Products outdoors or in places where the Products are exposed to direct sunlight or dust
 - [c] Use of our Products in places where the Products are exposed to sea wind or corrosive gases, including Cl₂, H₂S, NH₃, SO₂, and NO₂
 - [d] Use of our Products in places where the Products are exposed to static electricity or electromagnetic waves
 - [e] Use of our Products in proximity to heat-producing components, plastic cords, or other flammable items
 - [f] Sealing or coating our Products with resin or other coating materials
 - [g] Use of our Products without cleaning residue of flux (even if you use no-clean type fluxes, cleaning residue of flux is recommended); or Washing our Products by using water or water-soluble cleaning agents for cleaning residue after soldering
 - [h] Use of the Products in places subject to dew condensation
- 4) The Products are not subject to radiation-proof design.
- 5) Please verify and confirm characteristics of the final or mounted products in using the Products.
- 6) In particular, if a transient load (a large amount of load applied in a short period of time, such as pulse) is applied, confirmation of performance characteristics after on-board mounting is strongly recommended. Avoid applying power exceeding normal rated power; exceeding the power rating under steady-state loading condition may negatively affect product performance and reliability.
- 7) De-rate Power Dissipation (Pd) depending on Ambient temperature (Ta). When used in sealed area, confirm the actual ambient temperature.
- 8) Confirm that operation temperature is within the specified range described in the product specification.
- 9) ROHM shall not be in any way responsible or liable for failure induced under deviant condition from what is defined in this document.

● **Precaution for Mounting / Circuit board design**

- 1) When a highly active halogenous (chlorine, bromine, etc.) flux is used, the residue of flux may negatively affect product performance and reliability.
- 2) In principle, the reflow soldering method must be used; if flow soldering method is preferred, please consult with the ROHM representative in advance.

For details, please refer to ROHM Mounting specification

● **Precautions Regarding Application Examples and External Circuits**

- 1) If change is made to the constant of an external circuit, please allow a sufficient margin considering variations of the characteristics of the Products and external components, including transient characteristics, as well as static characteristics.
- 2) You agree that application notes, reference designs, and associated data and information contained in this document are presented only as guidance for Products use. Therefore, in case you use such information, you are solely responsible for it and you must exercise your own independent verification and judgment in the use of such information contained in this document. ROHM shall not be in any way responsible or liable for any damages, expenses or losses incurred by you or third parties arising from the use of such information.

● **Precaution for Electrostatic**

This Product is electrostatic sensitive product, which may be damaged due to electrostatic discharge. Please take proper caution in your manufacturing process and storage so that voltage exceeding the Products maximum rating will not be applied to Products. Please take special care under dry condition (e.g. Grounding of human body / equipment / solder iron, isolation from charged objects, setting of Ionizer, friction prevention and temperature / humidity control).

● **Precaution for Storage / Transportation**

- 1) Product performance and soldered connections may deteriorate if the Products are stored in the places where:
 - [a] the Products are exposed to sea winds or corrosive gases, including Cl₂, H₂S, NH₃, SO₂, and NO₂
 - [b] the temperature or humidity exceeds those recommended by ROHM
 - [c] the Products are exposed to direct sunshine or condensation
 - [d] the Products are exposed to high Electrostatic
- 2) Even under ROHM recommended storage condition, solderability of products out of recommended storage time period may be degraded. It is strongly recommended to confirm solderability before using Products of which storage time is exceeding the recommended storage time period.
- 3) Store / transport cartons in the correct direction, which is indicated on a carton with a symbol. Otherwise bent leads may occur due to excessive stress applied when dropping of a carton.
- 4) Use Products within the specified time after opening a humidity barrier bag. Baking is required before using Products of which storage time is exceeding the recommended storage time period.

● **Precaution for Product Label**

QR code printed on ROHM Products label is for ROHM's internal use only.

● **Precaution for Disposition**

When disposing Products please dispose them properly using an authorized industry waste company.

● **Precaution for Foreign Exchange and Foreign Trade act**

Since our Products might fall under controlled goods prescribed by the applicable foreign exchange and foreign trade act, please consult with ROHM representative in case of export.

● **Precaution Regarding Intellectual Property Rights**

- 1) All information and data including but not limited to application example contained in this document is for reference only. ROHM does not warrant that foregoing information or data will not infringe any intellectual property rights or any other rights of any third party regarding such information or data. ROHM shall not be in any way responsible or liable for infringement of any intellectual property rights or other damages arising from use of such information or data.:
- 2) No license, expressly or implied, is granted hereby under any intellectual property rights or other rights of ROHM or any third parties with respect to the information contained in this document.

●Other Precaution

- 1) The information contained in this document is provided on an “as is” basis and ROHM does not warrant that all information contained in this document is accurate and/or error-free. ROHM shall not be in any way responsible or liable for any damages, expenses or losses incurred by you or third parties resulting from inaccuracy or errors of or concerning such information.
- 2) This document may not be reprinted or reproduced, in whole or in part, without prior written consent of ROHM.
- 3) The Products may not be disassembled, converted, modified, reproduced or otherwise changed without prior written consent of ROHM.
- 4) In no event shall you use in any way whatsoever the Products and the related technical information contained in the Products or this document for any military purposes, including but not limited to, the development of mass-destruction weapons.
- 5) The proper names of companies or products described in this document are trademarks or registered trademarks of ROHM, its affiliated companies or third parties.

