



Bluetooth[®] Module – Part Code LM-071

Class 2 BC04

Features

- The module is a Max .4dBm(Class2) module.
- Bluetooth standard Ver. 2.0 + EDR certification .
- Low current consumption :
Hold,Sniff,Park ,Deep sleep Mode
- 3.0v to 3.6v operation
- Support for up to 7 ACL links and 3 SCO links
- Interface: USB, UART&PCM(for voice CODEC)
- SPP,HSP/HFP,HID,DUN firmware are available
- Support for 802.11 Co-Existence
- RoHS compliant
- Small outline. 25 x 14.5 x 2.2 mm

Applications

- PDA
- Cordless headset
- Digital camera & printer
- Access Points
- GPS,POS, Barcode Reader
- Domestic and industrial applications



General Electrical Specification

Parameter	Description	Min.	Typ.	Max.	Units
Operating Voltage (VDD)		3.00	3.30	3.60	V
RF Output Power	Measured in 50 ohm	-6	0	4	dBm
RX Sensitivity			-83	-80	dBm
Input Low Voltage	RESET,UART,GPIO,PCM	-0.30	-	0.80	V
Input High Voltage	RESET,UART,GPIO,PCM	0.70VDD	-	VDD+0.30	V
Output Low Voltage	UART,GPIO,PCM	-	-	0.40	V
Output High Voltage	UART,GPIO,PCM	VDD-0.40	-	-	V
Average Current Consumption	Deep sleep		40		uA
Average Current Consumption	ACL 40ms sniff		2.4		mA
Average Current Consumption	SCO connection HV1		39	-	mA
Peak Current	Tx burst +4dBm		-	58	mA

Block Diagram

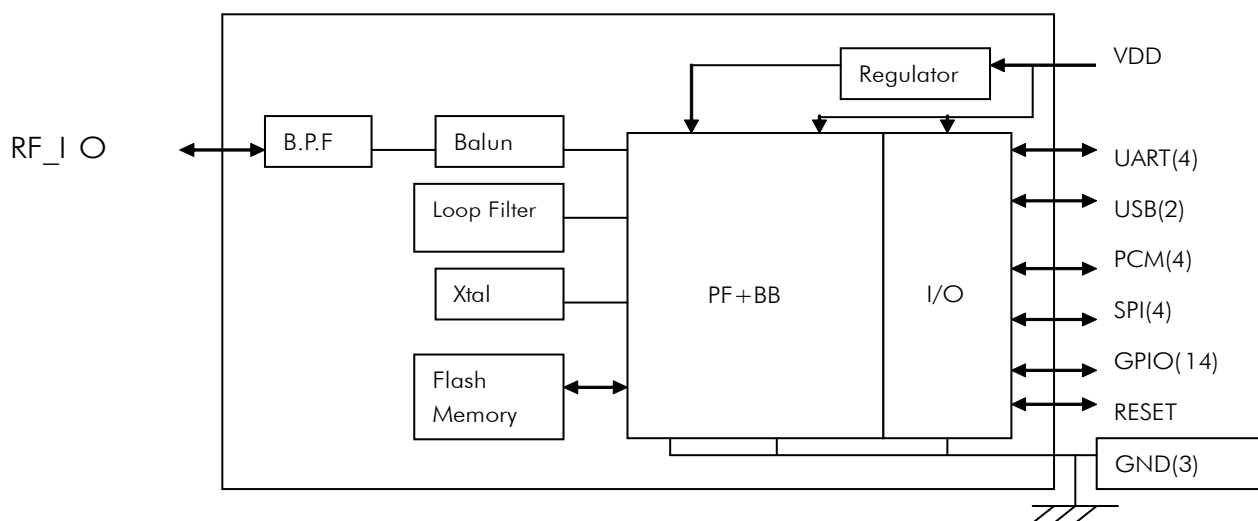



LM-071 Specifications

Radio Characteristics – Basic Data Rate

Radio Characteristics, VDD = 3.3V Temperature = +20°C						
	Frequency (GHz)	Min	Typ	Max	Bluetooth Specification	Unit
Sensitivity at 0.1% BER	2.402	-	-83	-82	≤ - 70	dBm
	2.441	-	-83	-82		dBm
	2.480	-	-83	-82		dBm
Maximum received signal at 0.1% BER	2.402	-	-6	0	≥ - 20	dBm
	2.441	-	-6	0		dBm
	2.480	-	-6	0		dBm
RF transmit power ⁽¹⁾	2.402	-	+2	-	-6 to +4 ⁽²⁾	dBm
	2.441	-	+2	-		dBm
	2.480	-	+2	-		dBm
Initial carrier frequency tolerance	2.402	-	12	20	±75	kHz
	2.441	-	10	20		kHz
	2.480	-	9	20		kHz
20dBm bandwidth for modulated carrier	2.402	-	879	1000	≤ 1000	kHz
	2.441	-	816	1000		kHz
	2.480	-	819	1000		kHz
Drift (single slot packet)	2.402	-	-	20	≤25	kHz
	2.441	-	-	20		kHz
	2.480	-	-	20		kHz
Drift (five slot packet)	2.402	-	-	20	≤40	kHz
	2.441	-	-	20		kHz
	2.480	-	-	20		kHz
Drift Rate	2.402	-	-	15	20	kHz/50µs
	2.441	-	-	15		kHz/50µs
	2.480	-	-	15		kHz/50µs
RF power control range		16	35	-	≥16	dB
RF power range control resolution		-	1.8	-	-	dB
f1 ^{avg} “Maximum Modulation”	2.402	145	165	175	140 < f1 ^{avg} < 175	kHz
	2.441	145	165	175		kHz
	2.480	145	165	175		kHz
f2 ^{maz} “Minimum Modulation”	2.402	115	150	-	115	kHz
	2.441	115	150	-		kHz
	2.480	115	150	-		kHz
C/I co-channel		-	10	11	≤= 11	dB
Adjacent channel selectivity C/I F=F ₀ + 1 MHz ⁽³⁾⁽⁵⁾		-	-4	0	≤= 0	dB
Adjacent channel selectivity C/I F=F ₀ - 1MHz ⁽³⁾⁽⁵⁾		-	-4	0	≤= 0	dB
Adjacent channel selectivity C/I F=F ₀ + 2 MHz ⁽³⁾⁽⁵⁾		-	-35	-30	≤= - 30	dB
Adjacent channel selectivity C/I F=F ₀ - 2MHz ⁽³⁾⁽⁵⁾		-	-21	-20	≤= - 20	dB
Adjacent channel selectivity C/I F>=F ₀ + 3 MHz ⁽³⁾⁽⁵⁾		-	-45	-	≤= - 40	dB
Adjacent channel selectivity C/I F<=F ₀ - 5 MHz ⁽³⁾⁽⁵⁾		-	-45	-	≤= - 40	dB



Adjacent channel selectivity C/I $F=F_{\text{image}}$ ⁽³⁾⁽⁵⁾	-	-18	-9	≤ -9	dB
Adjacent channel transmit power $F=F_0 \pm 2\text{MHz}$ ⁽⁴⁾⁽⁵⁾	-	-35	-20	≤ -20	dBc
Adjacent channel transmit power $F=F_0 \pm 3\text{MHz}$ ⁽⁴⁾⁽⁵⁾	-	-55	-40	≤ -40	dBc

Notes:

- (1) BlueCore-External firmware maintains the transmit power to be within the Bluetooth specification v2.0 limits.
- (2) Class 2 RF transmit power range, Bluetooth specification v2.0
- (3) Up to five exceptions are allowed in v2.0 of the Bluetooth specification
- (4) Up to three exceptions are allowed in v2.0 of the Bluetooth specification
- (5) Measured at $F_0 = 2441\text{MHz}$

Radio Characteristics – Enhanced Data Rate

Transmitter , VDD = 3.3V Temperature = +20°C						
	Frequency (GHz)	Min.	Typ.	Max.	Bluetooth Specification	Unit
Maximum RF transmit power	2.402	-6	0	+2	-6 to +20	dBm
	2.441	-6	0	+2		dBm
	2.480	-6	0	+2		dBm
Relative transmit power		-	-1.5	-	-4 to +1	dB
$\pi/4$ DQPSK Maximum carrier frequency stability w_0		-	2	-	$\leq \pm 10$ for all blocks	kHz
$\pi/4$ DQPSK Maximum carrier frequency stability w_i		-	6	-	$\leq \pm 75$ for all packets	kHz
$\pi/4$ DQPSK Maximum carrier frequency stability $ w_0 + w_i $		-	8	-	$\leq \pm 75$ for all blocks	kHz
8 DPSK Maximum carrier frequency stability w_0		-	2	-	$\leq \pm 10$ for all blocks	kHz
8 DPSK Maximum carrier frequency stability w_i		-	6	-	$\leq \pm 75$ for all packets	kHz
8 DPSK Maximum carrier frequency stability $ w_0 + w_i $		-	8	-	$\leq \pm 75$ for all blocks	kHz
$\pi/4$ DQPSK Modulation Accuracy	RMS DVEM	-	7	-	≤ 20	%
	99% DEVM	-	13	-	≤ 30	%
	Peak DEVM	-	19	-	≤ 35	%
8 DPSK Modulation Accuracy	RMS DVEM	-	7	-	≤ 13	%
	99% DEVM	-	13	-	≤ 20	%
	Peak DEVM	-	17	-	≤ 25	%
In-band spurious emissions	$F > F_0 + 3\text{ MHz}$	-	<-50	-	≤ -40	dBm
	$F < F_0 - 3\text{ MHz}$	-	<-50	-	≤ -40	dBm



Adjacent channel selectivity C/I F=F _{image}	$\pi/4$ DQPSK		-20		≤ -7	dB
	8 DPSK		-15		≤ 0	dB

LM-071 Pin Functions

PIN	NAME	TYPE	FUNCTION
1	PIO(8)	Bi-directional	Programmable Input/Output line
2	PIO(9)	Bi-directional	Programmable Input/Output line
3	PIO(10)	Bi-directional	Programmable Input/Output line
4	AIO0	Bi-directional	Programmable Input/Output Line , 32KHz sleep clock input
5	AIO1	Bi-directional	Programmable Input/Output Line
6	RESET	CMOS input	Reset if high. Input debounced so must be high for >5ms to cause a reset
7	SPI_MISO	CMOS Output	Serial Peripheral Interface Data Output
8	SPI_CSB	CMOS Input	Chip Select For Synchronous Serial Interface active low
9	SPI_CLK	CMOS Input	Serial Peripheral Interface Clock
10	SPI_MOSI	CMOS Input	Serial Peripheral Interface Data Input
11	UART_CTS	CMOS Input	UART Clear To Send (Active Low)
12	UART_TX	CMOS Output	UART Data Output
13	UART_RTS	CMOS Output	UART Request To Send (Active Low)
14	UART_RX	CMOS Input	UART Data Input
15	PIO(11)	Bi-directional	Programmable Input/Output line
16	3V3	Power	3.3V Power Supply Input
17	GND	GND	Ground
18	PCM_OUT	CMOS Output	Synchronous Data Output
19	PCM_SYNC	Bi-directional	Synchronous Data Sync
20	PCM_IN	CMOS Input	Synchronous Data Input
21	PCM_CLK	Bi-directional	Synchronous Data Clock
22	USB_DP	Bi-directional	USB Data Plus
23	USB_DN	Bi-directional	USB Data Minus
24	PIO(7)	Bi-directional	Programmable Input/Output line
25	PIO(6)	Bi-directional	Programmable Input/Output line , CLK_REQ , WLAN_Ative/Ch_Data input
26	PIO(5)	Bi-directional	Programmable Input/Output line , USB_DETACH, BT_Ative output
27	PIO(4)	Bi-directional	Programmable Input / Output Line , USB_ON, BT_Priority/Ch_Clk Output
28	PIO(3)	Bi-directional	Programmable Input/Output Line , USB_WAKE_UP, CLK_REQ_IN
29	PIO(2)	Bi-directional	Programmable Input / Output Line , USB_PULL_UP, CLK_REQ_OUT
30	PIO(1)	Bi-directional	Programmable Input/Output Line , TX Enable
31	PIO(0)	Bi-directional	Programmable Input / Output Line , RX Enable
32	GND	GND	Ground
33	RF_IO	Analogue	50 ohm Antenna connection
34	GND	GND	Ground



	F=F ₀ -3 MHz	-	-46	-	≤ -40	dBm
	F=F ₀ -2 MHz	-	-34	-	≤ -20	dBm
	F=F ₀ -1 MHz	-	-35	-	≤ -26	dBm
	F=F ₀ +1 MHz	-	-35	-	≤ -26	dBm
	F=F ₀ +2 MHz	-	-31	-	≤ -20	dBm
	F=F ₀ +3 MHz	-	-33	-	≤ -40	dBm
EDR Differential Phase Encoding			No Errors		≥ 99	%

Receiver , VDD =3.3V Temperature = +20°C

	Modulation	Min.	Typ.	Max.	Bluetooth Specification	Unit
Sensitivity at 0.1% BER	π/4 DQPSK	-	-82	-	≤ -70	dBm
	8 DPSK	-	-76	-	≤ -70	dBm
Maximum received signal level at 0.1% BER	π/4 DQPSK	-	-8	-	≥ -20	dBm
	8 DPSK	-	-10	-	≥ -20	dBm
C/I co-channel at 0.1% BER	π/4 DQPSK	-	10	-	≤ +13	dB
	8 DPSK	-	19	-	≤ +21	dB
Adjacent channel selectivity C/I F=F ₀ +1 MHz	π/4 DQPSK	-	-10	-	≤ 0	dB
	8 DPSK	-	-5	-	≤ +5	dB
Adjacent channel selectivity C/I F=F ₀ -1 MHz	π/4 DQPSK	-	-11	-	≤ 0	dB
	8 DPSK	-	-5	-	≤ +5	dB
Adjacent channel selectivity C/I F=F ₀ +2 MHz	π/4 DQPSK	-	-40	-	≤ -30	dB
	8 DPSK	-	-40	-	≤ -25	dB
Adjacent channel selectivity C/I F=F ₀ -2 MHz	π/4 DQPSK	-	-23	-	≤ -20	dB
	8 DPSK	-	-20	-	≤ -13	dB
Adjacent channel selectivity C/I F=F ₀ +3 MHz	π/4 DQPSK	-	-45	-	≤ -40	dB
	8 DPSK	-	-45	-	≤ -33	dB
Adjacent channel selectivity C/I F=F ₀ -5 MHz	π/4 DQPSK	-	-45	-	≤ -40	dB
	8 DPSK	-	-45	-	≤ -33	dB

F₀ = 2405, 2441, 2477 MHz



LM-071 Pin out Information

PIN DETAILS VIEWED FROM TOP SIDE

1	34
PIO(8)	GND
PIO(9)	RF_IO
PIO(10)	GND
AIO(0)	PIO(0)
AIO(1)	PIO(1)
RESET	PIO(2)
SPI_MISO	PIO(3)
SPI_CSB	PIO(4)
SPI_CLK	PIO(5)
SPI_MOSI	PIO(6)
UART_CTS	PIO(7)
UART_TX	USB_DN
UART_RTS	USB_DP
UART_RX	PCM_CLK
PIO(11)	PCM_IN
3V3	PCM_SYNC
GND	PCM_OUT
17	18

MODULE PAD AND SOLDER MASK DETAILS

SOLDER MASK WINDOW 1.0mm MAX

SOLDER PAD 0.8mm

MECHANICAL DETAILS VIEWED FROM TOP/BOTTOM SIDE

