

euro-block

product specification

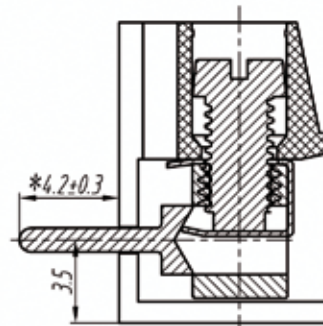

SECTION A-A

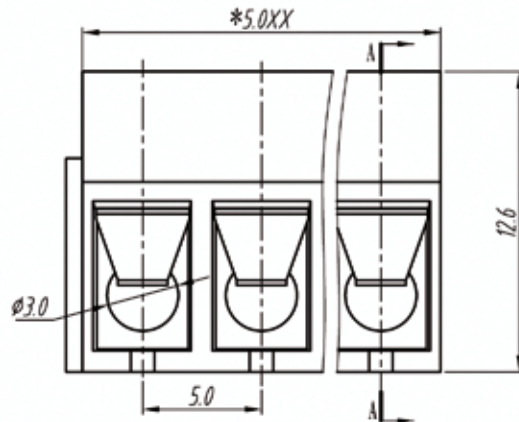
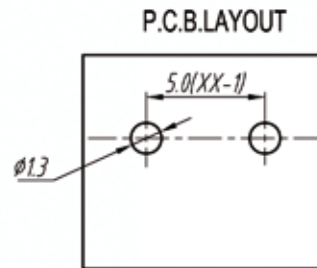
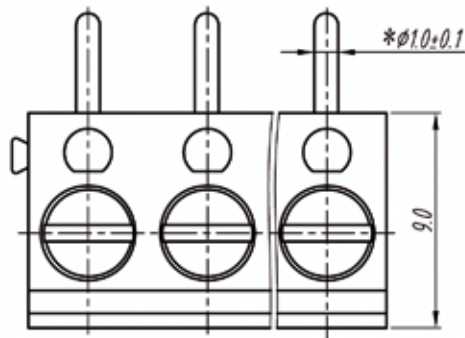

Electrical

Standard: UL-IEC
 Rated voltage: 300V-250V
 Rated current: 16A-24A
 Wire range: 22-14AWG-2.5mm²
 Withstanding voltage: AC2000V/1Min

Mechanical

Torque: 0.5Nm (4.5Lb'in)
 Temp.Range: -30°C~+120°C
 Strip length: 4.5-5mm

Dimensions

Pitch: 5.00mm (0.197")
 Poles: 2p-xxp

Material

Housing: PBT, UL94V-0
 Screws: M3, steel, Zinc plated
 Pin header: Brass, Tin plated
 Wire guard: Phosphor bronze, Ni plated

TOLERANCES EXCEPT AS NOTED

variable range	linear dimension				fillet	chamfer	short angle sid			≡	-	□	//	⊥		
	to 6	over 6 to 30	over 30 to 120	over 120 to 480	all	to 6	to 10	to 30	to 50	to 120	to 5	to 30	to 120	to 120		
tolerance	±0.1	±0.2	±0.3	±0.5	±0.2	±0.5	±1	1'	30'	20'	10'	0.5	0.025	0.06	0.12	0.4

UNITS	mm	SIZE	A4	SCALE	FIRST ANGLE PROJECTION	
euro-block						
					NAME	MLT52-H